

### Specifications:

**Housing:** Mount housing, mount cover, and wiring compartment cover made from cast C84400 bronze and assembled with 18-8 stainless steel hardware.

**Seals:** O-ring groove on mount allows for use of an O-ring to prevent leaking between cover and fixture knuckle. (Note: All Vision3 fixtures come with a high temperature, black Viton O-ring on the knuckle for this purpose). Mount cover and wiring cover use self-adhesive, high temperature, silicone gaskets to prevent leaking. A water tight 3-wire pass-thru reduces the possibility of water entering the housing in the event of the wiring compartment becoming flooded.

**Electrical:** Mount housing is cast with two 3/4" NPT and one 1/2" NPT conduit entries on the bottom of the wiring compartment for conduit connection, cable entry, and feed through wiring. (Conduit, cable, and plugs for unused entries not included.)

**Finish:** TGIC thermo-set polyester powder coat paint available in 14 standard colors. Also available in two bronze metal finishes: Natural and Aged.

**Certification:** CSA tested & certified to US and Canadian safety standards for wet location landscape use per UL1598 & CSA C22.2 No. 250-00.

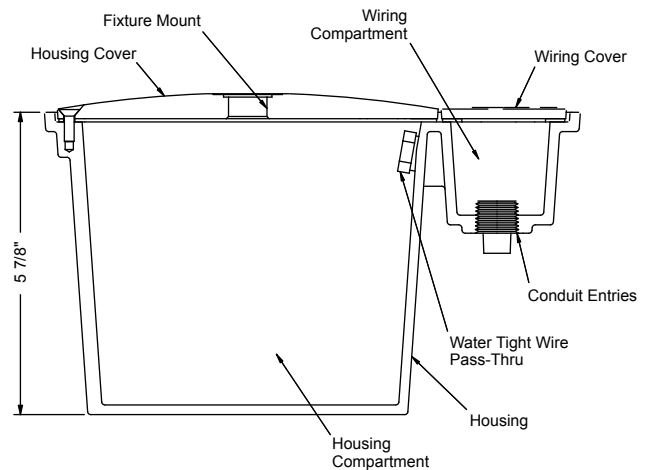
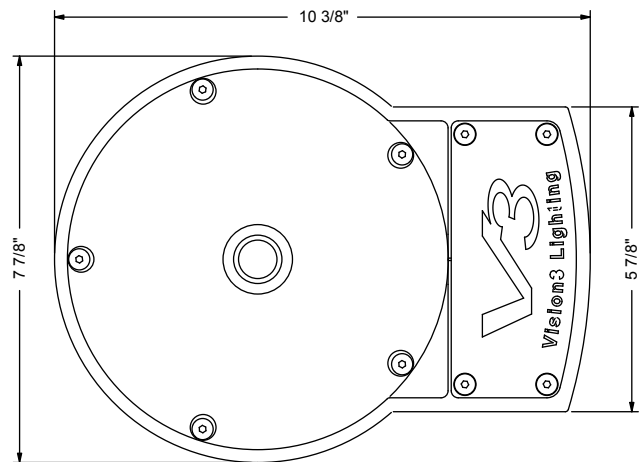

### Ordering Information:

MO11	
Model	Finish
	BL - Black
	BLT - Textured Black
	BN - Bronze
	BNT - Textured Bronze
	BAT - Textured Bark
	WI - White
	GRT - Textured Green
	SI - Silver
	GY - Grey
	BE - Beige
	GNT - Textured Granite
	SAT - Textured Sand
	PAT - Textured Patina
	EAT - Textured Earth
	NAT - Natural
	AGE - Aged

#### Notes:

- Specifications, certifications, and ordering information are subject to change. Please check website for latest specification sheets.

Example: **MO11 - AGE**