

## Installation Instructions

### INSTRUCTIONS PERTAINING TO A RISK OF FIRE, OR INJURY TO PERSONS. IMPORTANT SAFETY INSTRUCTIONS

#### Warning! To reduce the risk of FIRE OR INJURY TO PERSONS:

1. Do not touch luminaire while lamp is on. Turn off/unplug and allow to cool before replacing lamp.
2. Lamp gets HOT quickly! Contact only switch/plug when turning on.
3. Do not touch hot lens, body, or cap.
4. Keep lamp away from materials that may burn.
5. Do not touch lamp at any time. Use a soft cloth. Oil from your skin may damage lamp.
6. Do not operate the luminaire with damaged or missing parts.
8. Do not install luminaire within 10 feet of a pool, spa, or fountain.
9. Have fixture installed in accordance with all applicable installation codes and standards by a person familiar with the construction and operation of the fixture and the hazards involved.
10. Use only cable properly rated for the application. Cable buried more than 6" must be suitable for direct burial. Direct burial cable may be ordered from Vision3 Lighting.

### SAVE THESE INSTRUCTIONS

#### Un-assemble & Inspect:

1. Unpack the PA2 Marker Light from its shipping container. Note: The PA2 Marker Light may be packaged partially un-assembled for ease of handling and shipping.
2. Check that there are no damaged or missing components.
3. If the Surface Mount Adapter is assembled to the Mount Cap, loosen the three Mount Cap Screw's using a 3/32" hex tool.
4. Remove the Surface Mount Adapter from the Mount Cap.

#### Installation:

1. Mount the Surface Mount Adapter using the appropriate size and type of Hex Head bolt for the surface being mounted to. (See Surface Mount Adapter Hole Pattern)
2. If the PA2 Marker Light was shipped partially un-assembled, assemble the Cap Assembly, Stem/Body Assembly, and Mount Cap as shown.
3. Cut the Fixture Leads to required length, if necessary, and connect to power supply leads using the appropriate size wire nuts (not supplied). Ensure that luminaire is rated for power being supplied. Note: Check all applicable building codes for requirements regarding appropriate size and usage of wire nuts and low voltage cable. It is also recommended that watertight wire nuts be used.
4. Slip the Mount Cap over the Surface Mount Adapter.
5. Tighten the three Mount Cap Screw's using a 3/32" hex tool.

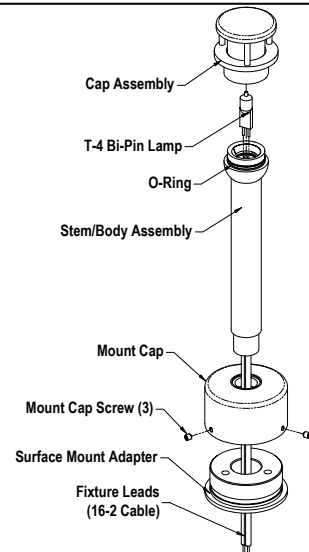

#### Lamp Installation/Replacement:

1. **Caution..Luminaire may be hot!** Allow to cool before replacing lamp. Remove Cap Assembly by holding Body, and unthreading Cap Assembly counterclockwise. Note: Hold Cap Assembly at base, below lens, while unthreading.
2. If replacing lamp, remove old lamp. Note: Be sure lamp is not hot!
3. Inspect O-Ring for cracks or cuts. Replace or clean if needed.
4. Install new T4 bi-pin, 35 watt max. lamp. Note: Do not touch new lamp with bare hands. Use a clean cotton cloth to install.
5. Install Cap Assembly by holding Body and threading on Cap Assembly clockwise. Note: Hold Cap Assembly at base, below lens, while threading.

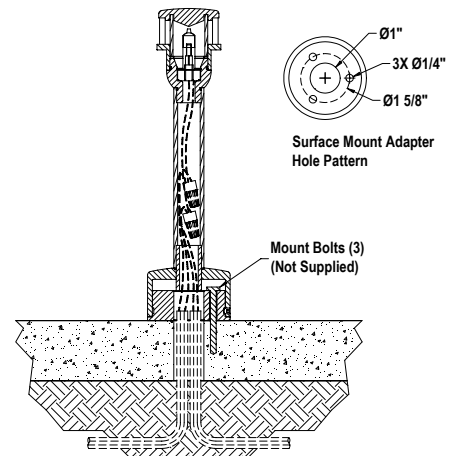

## Installation Instructions

### INSTRUCTIONS PERTAINING TO A RISK OF FIRE, OR INJURY TO PERSONS. IMPORTANT SAFETY INSTRUCTIONS

#### Warning! To reduce the risk of FIRE OR INJURY TO PERSONS:

1. Do not touch luminaire while lamp is on. Turn off/unplug and allow to cool before replacing lamp.
2. Lamp gets HOT quickly! Contact only switch/plug when turning on.
3. Do not touch hot lens, body, or cap.
4. Keep lamp away from materials that may burn.
5. Do not touch lamp at any time. Use a soft cloth. Oil from your skin may damage lamp.
6. Do not operate the luminaire with damaged or missing parts.
8. Do not install luminaire within 10 feet of a pool, spa, or fountain.
9. Have fixture installed in accordance with all applicable installation codes and standards by a person familiar with the construction and operation of the fixture and the hazards involved.
10. Use only cable properly rated for the application. Cable buried more than 6" must be suitable for direct burial. Direct burial cable may be ordered from Vision3 Lighting.

### SAVE THESE INSTRUCTIONS

#### Un-assemble & Inspect:

1. Unpack the PA2 Marker Light from its shipping container. Note: The PA2 Marker Light may be packaged partially un-assembled for ease of handling and shipping.
2. Check that there are no damaged or missing components.
3. If the Stake is assembled to the Mount Cap, loosen the three Mount Cap Screw's using a 3/32" hex tool.
4. Remove the Stake from the Mount Cap.

#### Installation:

1. At the desired location, prepare an appropriate size hole for the Stake.
2. Run conduit and/or cable (not supplied) to the prepared hole. Note: Check all applicable building codes for requirements regarding landscape lighting conduit and cable.
3. Feed the supply wires (not supplied) through the bottom of the Stake, leaving enough extended for wiring to the Fixture Leads.
4. Place the Stake in-grade so that the line on the Grade Label is at grade. Note: Use caution to avoid damaging the supply wires.
5. Secure the Stake in-grade by filling in the hole.
6. If the PA2 Marker Light was shipped partially un-assembled, assemble the Cap Assembly, Stem/Body Assembly, and Mount Cap as shown.
7. Cut the Fixture Leads to required length, if necessary, and connect to power supply leads using the appropriate size wire nuts (not supplied). Ensure that the luminaire is rated for power being supplied. Note: Check all applicable building codes for requirements regarding appropriate size and usage of wire nuts. It is also recommended that watertight wire nuts be used.
8. Slip the Mount Cap over the Stake.
9. Tighten the three Mount Cap Screw's using a 3/32" hex tool.

#### Lamp Installation/Replacement:

1. **Caution..Luminaire may be hot!** Allow to cool before replacing lamp. Remove Cap Assembly by holding Body, and unthreading Cap Assembly counterclockwise. Note: Hold Cap Assembly at base, below lens, while unthreading.
2. If replacing lamp, remove old lamp. Note: Be sure lamp is not hot!
3. Inspect O-Ring for cracks or cuts. Replace or clean if needed.
4. Install new T4 bi-pin, 35 watt max. lamp. Note: Do not touch new lamp with bare hands. Use a clean cotton cloth to install.
5. Install Cap Assembly by holding Body and threading on Cap Assembly clockwise. Note: Hold Cap Assembly at base, below lens, while threading.

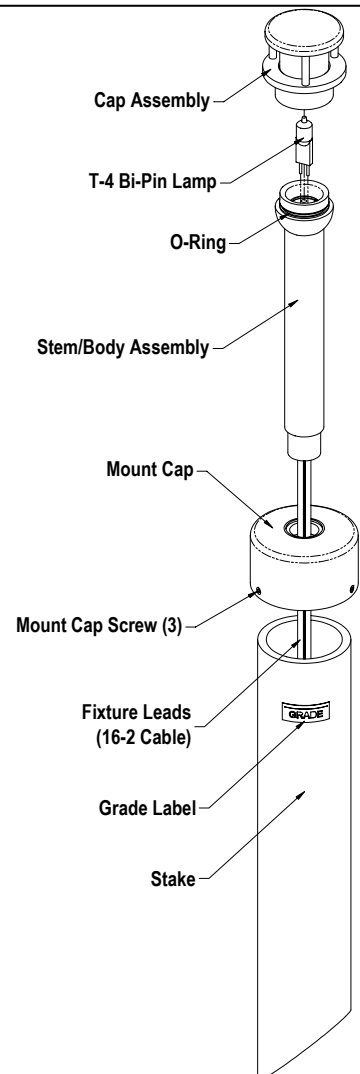

### Installation Instructions

#### INSTRUCTIONS PERTAINING TO A RISK OF FIRE, OR INJURY TO PERSONS. IMPORTANT SAFETY INSTRUCTIONS

#### Warning! To reduce the risk of FIRE OR INJURY TO PERSONS:

1. Do not touch luminaire while lamp is on. Turn off/unplug and allow to cool before replacing lamp.
2. Lamp gets HOT quickly! Contact only switch/plug when turning on.
3. Do not touch hot lens, body, or cap.
4. Keep lamp away from materials that may burn.
5. Do not touch lamp at any time. Use a soft cloth. Oil from your skin may damage lamp.
6. Do not operate the luminaire with damaged or missing parts.
8. Do not install luminaire within 10 feet of a pool, spa, or fountain.
9. Have fixture installed in accordance with all applicable installation codes and standards by a person familiar with the construction and operation of the fixture and the hazards involved.
10. Use only cable properly rated for the application. Cable buried more than 6" must be suitable for direct burial. Direct burial cable may be ordered from Vision3 Lighting.

#### SAVE THESE INSTRUCTIONS

##### Un-assemble & Inspect:

1. Unpack the PA2 Marker Light from its shipping container. Note: The PA2 Marker Light may be packaged partially un-assembled for ease of handling and shipping.
2. Check that there are no damaged or missing components.
3. If the Stake is assembled to the Adjustable Mount Cap, loosen the three Mount Cap Screw's using a 3/32" hex tool.
4. Remove the Stake from the Adjustable Mount Cap.

##### Installation:

1. At the desired location, prepare an appropriate size hole for the Stake.
2. Run cable (not supplied) to the prepared hole. Note: Check all applicable building codes for requirements regarding landscape lighting cable.
3. Feed the supply wires (not supplied) through the bottom of the Stake, leaving enough extended for wiring to the Fixture Leads.
4. Place the Stake in-grade so that the line on the Grade Label is at grade. Note: Use caution to avoid damaging the supply wires.
5. Secure the Stake in-grade by filling in the hole.
6. If the PA2 Marker Light was shipped partially un-assembled, assemble the Cap Assembly, Stem/Body Assembly, and Mount Cap as shown.
7. Cut the Fixture Leads to required length, if necessary, and connect to power supply leads using the appropriate size wire nuts (not supplied). Ensure that the luminaire is rated for power being supplied. Note: Check all applicable building codes for requirements regarding appropriate size and usage of wire nuts. It is also recommended that watertight wire nuts be used.
8. Slip the Mount Cap over the Stake.
9. Tighten the three Mount Cap Screw's using a 3/32" hex tool.

##### Height Adjustment:

1. Loosen the three Stem Adjusting Screw's using a 3/32" hex tool.
2. Raise/lower the fixture to the desired height. **Caution! Fixture may be hot!**
3. Tighten the three Stem Adjusting Screw's using a 3/32" hex tool.

##### Lamp Installation/Replacement:

1. **Caution..Luminaire may be hot!** Allow to cool before replacing lamp. Remove Cap Assembly by holding Body, and unthreading Cap Assembly counterclockwise. Note: Hold Cap Assembly at base, below lens, while unthreading.
2. If replacing lamp, remove old lamp. Note: Be sure lamp is not hot!
3. Inspect O-Ring for cracks or cuts. Replace or clean if needed.
4. Install new T4 bi-pin, 35 watt max. lamp. Note: Do not touch new lamp with bare hands. Use a clean cotton cloth to install.
5. Install Cap Assembly by holding Body and threading on Cap Assembly clockwise. Note: Hold Cap Assembly at base, below lens, while threading.

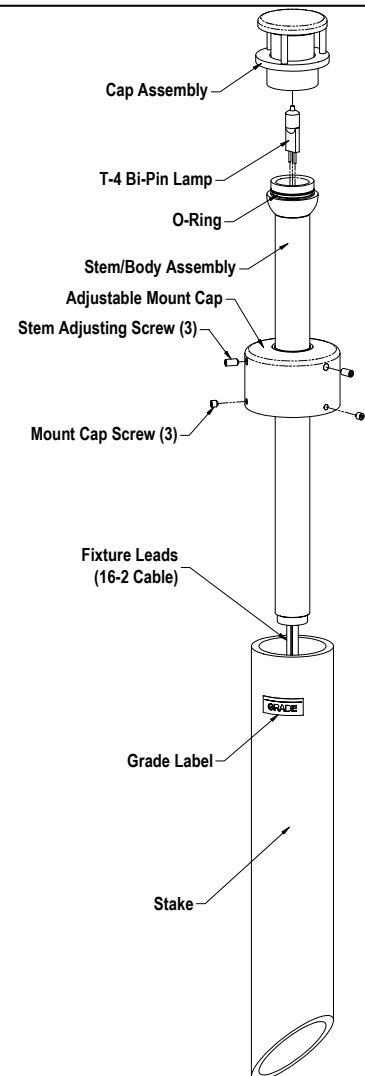

## Installation Instructions

### INSTRUCTIONS PERTAINING TO A RISK OF FIRE, OR INJURY TO PERSONS. IMPORTANT SAFETY INSTRUCTIONS

#### Warning! To reduce the risk of FIRE OR INJURY TO PERSONS:

1. Do not touch luminaire while lamp is on. Turn off/unplug and allow to cool before replacing lamp.
2. Lamp gets HOT quickly! Contact only switch/plug when turning on.
3. Do not touch hot lens, body, or cap.
4. Keep lamp away from materials that may burn.
5. Do not touch lamp at any time. Use a soft cloth. Oil from your skin may damage lamp.
6. Do not operate the luminaire with damaged or missing parts.
8. Do not install luminaire within 10 feet of a pool, spa, or fountain.
9. Have fixture installed in accordance with all applicable installation codes and standards by a person familiar with the construction and operation of the fixture and the hazards involved.
10. Use only cable properly rated for the application. Cable buried more than 6" must be suitable for direct burial. Direct burial cable may be ordered from Vision3 Lighting.

### SAVE THESE INSTRUCTIONS

#### Un-assemble & Inspect:

1. Unpack the PA2 Marker Light from its shipping container. Note: The PA2 Marker Light may be packaged partially un-assembled for ease of handling and shipping.
2. Check that there are no damaged or missing components.
3. If the Junction Stake is assembled to the Mount Cap, loosen the three Mount Cap Screw's using a 3/32" hex tool.
4. Remove the Junction Stake from the Mount Cap.

#### Install Stake Body In-grade:

1. At the desired location, prepare an appropriate size hole for the Junction Stake.
2. Run conduit and/or cable (not supplied) to the prepared hole. Note: Check all applicable building codes for requirements regarding landscape lighting conduit and cable.
3. Place the Junction Stake in-grade and attach the supply conduit to the Conduit Connector fittings using PVC cement appropriate for underground electrical conduit.
4. Adjust the Junction Stake so that the line on the Grade Label is at grade.
5. Secure the Junction Stake in-grade by filling in the hole.
6. Feed enough supply wiring through the conduit into the Junction Stake to facilitate connection with luminaire.
7. If the PA2 Marker Light was shipped partially un-assembled, assemble the Cap Assembly and Stem/Body/Transformer Assembly as shown.
8. Using the appropriate sized wire nuts (not supplied), connect the supply wires to the black and white Transformer Input Wires. Note: Check that the transformer is correctly rated for the supply power.
9. Using the appropriate sized wire nut (not supplied), connect the supply ground wire to the green Ground Lead coming from the bracket holding the Transformer.
10. Clean the Junction O-Ring and examine for any nicks or cuts.
11. Slip the Mount Cap over the Junction Stake. Note: Twisting cap while pushing over O-Ring will ease installation.
12. Tighten the three Mount Cap Screw's using a 3/32" hex tool.

#### Lamp Installation/Replacement:

1. **Caution..Luminaire may be hot!** Allow to cool before replacing lamp. Remove Cap Assembly by holding Body, and unthreading Cap Assembly counterclockwise. Note: Hold Cap Assembly at base, below lens, while unthreading.
2. If replacing lamp, remove old lamp. Note: **Be sure lamp is not hot!**
3. Inspect O-Ring for cracks or cuts. Replace or clean if needed.
4. Install new T4 bi-pin, 35 watt max. lamp. Note: Do not touch new lamp with bare hands. Use a clean cotton cloth to install.
5. Install Cap Assembly by holding Body and threading on Cap Assembly clockwise. Note: Hold Cap Assembly at base, below lens, while threading.

