



PAR30/PAR38 Wall Mount **MODEL WM13**

120 Volt, 120 Watt Max., PAR30/PAR38 Halogen

Specifications:

Material: Available in machined 6061-T6 aluminum.

Cap: Machined 6061-T6 aluminum cap mounts with five 18-8 stainless steel captive fasteners, and seals by compressing a molded high temperature black silicone gasket around the lens and against the body. Up to two lens accessories can be used, and are held in the molded silicone lens gasket.

Mount Canopy: Available with the following mount options: MO3 (Machined Round Canopy), MO15 (Machined Square Canopy), and MO12 & MO13 (Surface Mount Powered Canopies). Stem is permanently attached to the mount canopy to prevent loosening. MO3 & MO15 mount options come mounted to a steel universal mounting ring for ease of mounting and adjustment on an industry standard round junction box (box and hardware not supplied). See mount specification sheets for more information. (Mount canopy must be mounted to an appropriate wall or junction box, in such a manner that is capable of holding the weight of the fixture. Junction box and hardware not included).

Finish: TGIC thermo set polyester powder coat paint available in 14 standard colors, applied over a corrosion resistant chromate conversion coating. Available in one additional metal finish: Clear Anodized.

Socket: Medium Base Porcelain Lamp holder with copper alloy, nickel-plated screw shell and center contact, and 600V, 250° C, PTFE coated 18 ga leads.

Lamp: 120 Volt medium base 'long neck' PAR30 halogen up to 75 Watts, or 120 Volt medium base PAR38 halogen up to 120 Watts.

Lens: Tempered, 1/4" thick, stepped lens allows for flush mounting.

Certification: CSA tested & certified to US and Canadian safety standards for the following applications:

Wet location wall mount use (UL1598):

WM13A - 75W Max. PAR30 Halogen lamp.

WM13A - 120W Max. PAR38 Halogen lamp.

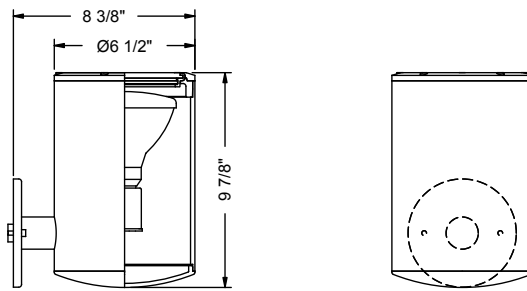

(Shown with MO3 Mount)

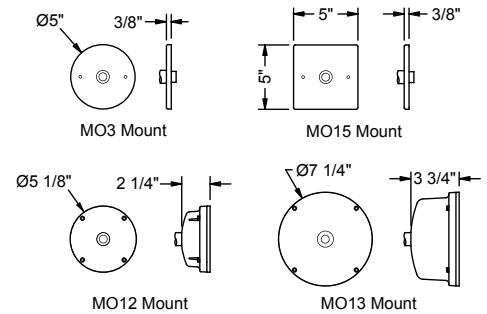

Ordering Information:

WM13A								
Model	Finish	Mount ¹	Lamp ³		Lens Accy ^{2,3}	Filter ^{2,3}	Louver ^{2,3}	
WM13A - Aluminum	BL - Black BLT - Textured Black BN - Bronze BNT - Textured Bronze BAT - Textured Bark WI - White GRT - Textured Green SI - Silver GY - Grey BE - Beige GNT - Textured Granite SAT - Textured Sand PAT - Textured Patina EAT - Textured Earth CLA - Clear Anodized	MO3 - Round Canopy MO15 - Square Canopy MO12 - Surface Mount Canopy MO13 - Surface Mount Canopy	0 - None	PAR30 Halogen: 34 - 50W, 9° Narrow Spot 35 - 50W, 16° Spot 36 - 50W, 30° Flood 37 - 50W, 40° Wide Flood 38 - 75W, 9° Narrow Spot 39 - 75W, 16° Spot 40 - 75W, 30° Flood 41 - 75W, 40° Wide Flood	PAR38 Halogen: 42 - 90W, 9° Narrow Spot 43 - 90W, 12° Spot 44 - 90W, 30° Flood 45 - 120W, 10° Narrow Spot 46 - 120W, 30° Flood 47 - 120W, 55° Wide	0 - None L1 - Spread Lens L2 - Linear Lens L3 - Softening Lens	0 - None F1 - Red F2 - Blue F3 - Light Blue F4 - Green F5 - Amber F6 - Pink	0 - None H1 - Honeycomb Louver

Notes:

- See MO3, MO12, MO13, or MO15 specification sheet for mount details.
- Only two lens options may be specified.
- CFL lamps available separately. Contact your Vision3 lighting CSR. (Lens options may not be used with CFL lamps.)
- Specifications, certifications, and ordering information are subject to change. Please check website for latest specification sheets.

Example: **WM13A - BL - MO15 - 39 - L3 - 0 - 0**