

CONSTRUCTION

- A** Housing - Consists of two heavy gauge aluminium parts spun together to form one. An internal plate equipped with hinges and made of steel provides access to the ballast and its electrical components.
- B** Mounting arm - Made of one piece moulded 356 aluminium alloy, fits on a Ø2-3/8" (60 mm) tenon and is fixed by four stainless steel set screws with nylon nuts.

OPTICS

- C** Drop lens - Made of one piece thermoformed acrylic, clear and impact resistant provided with an hinge and a screw that allow easy access to the internal components. A high-strength EPDM gasket ensures sealing and prevents dust from infiltrating inside the luminaire.
- D** Reflector - Made of segmented specular aluminium for multi-image duplication of the luminous arc. Offers a photometric distribution of IES type II, III, IV or V.

ELECTRICAL COMPONENTS

- Ballast - Easily accessible, the ballast is mounted on a removable heavy gauge galvanized steel tray, is equipped with a quick disconnect wiring system and is factory pre wired and tested. It has a high power-factor of 90% or more and is either CWA, CWI, HX, or reactor type. All electrical components are CSA and UL approved.
- Socket - Made of porcelain and 4KV pulse rated. For 175W or less, medium base and for 200W or more, mogul base (lamp not included).

FINISH

- All surfaces are chemically treated against corrosion through a multi-stage immersion process. The polyester powder finish is applied by a thermostatic process offering an excellent protection conforming to ASTM G7, D-2247 and B-117/D-1654 standards. Standard colours are black, bronze and white with a textured finish. Consult SDL's "Colour Selection Guide" for others.

OPTIONS

- Photoelectric cell - Integrated in a button type polymer housing. CSA and UL approved.

HARDWARE

- All exterior hardware is made of stainless steel.

WARRANTY

- This product has a three year warranty on the finish and against any manufacturing defect. The ballast and its components are covered by the manufacturer's warranty.

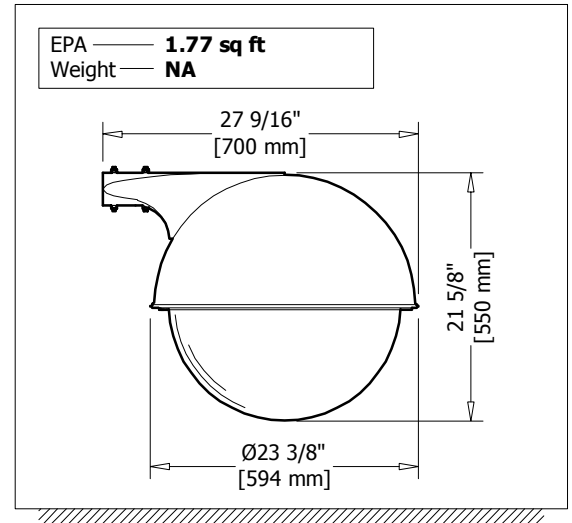
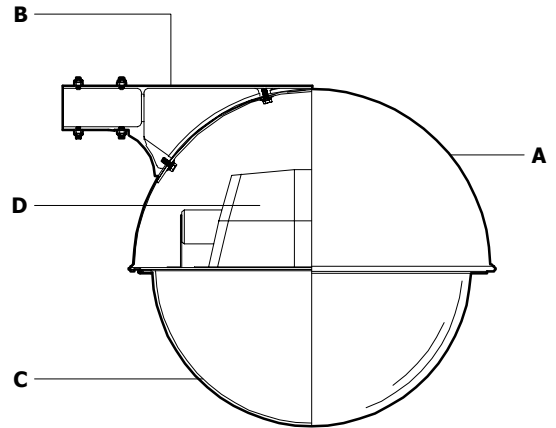

Type	Quantity	Model	Distribution	Wattage	Voltage	Colour	Other components
<input type="text"/>	<input type="text"/>	<input type="text"/>	<input type="text"/>	<input type="text"/>	<input type="text"/>	<input type="text"/>	<input type="text"/>
Submitted on _____ for <input type="checkbox"/> Information <input type="checkbox"/> Approval				Project — _____			
Socket — <input type="checkbox"/> Medium <input type="checkbox"/> Mogul <input type="checkbox"/> _____				Distributor — _____			
Other(s) — _____				Your order # — _____			
_____				Representative — _____			
_____				Our order # — _____			

- Assembly detail(s) -

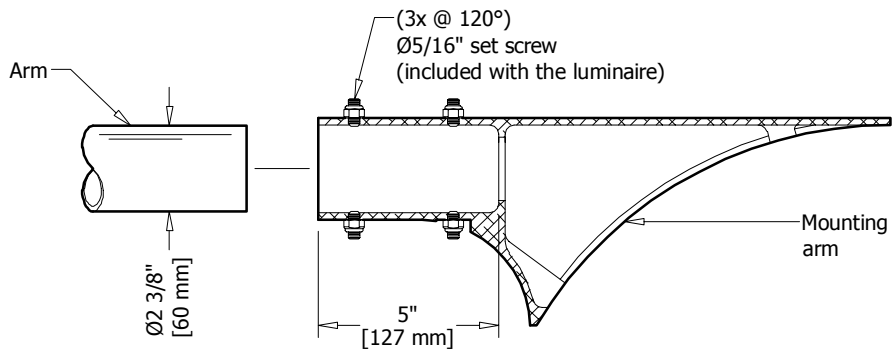

- Specification guide -

Distribution	Wattage	Voltage	Colour	Other components
Reflector Type 2 <input type="checkbox"/> RD2 Type 3 <input type="checkbox"/> RD3 Type 4 <input type="checkbox"/> RD4 Type 5 <input type="checkbox"/> RD5	MH 175H <input type="checkbox"/> 250H <input type="checkbox"/> 400H <input type="checkbox"/> MH pulse start 200P <input type="checkbox"/> 250P <input type="checkbox"/> 320P <input type="checkbox"/> 350P <input type="checkbox"/> 400P <input type="checkbox"/> HPS 200S <input type="checkbox"/> 250S <input type="checkbox"/> 400S <input type="checkbox"/> Others ★ <input type="checkbox"/> Mogul socket only	120 <input type="checkbox"/> 208 <input type="checkbox"/> 240 <input type="checkbox"/> 277 <input type="checkbox"/> 347 <input type="checkbox"/>	Standard Colours Textured black <input type="checkbox"/> A11 Textured bronze <input type="checkbox"/> B11 Textured white <input type="checkbox"/> C11 Special Colours Textured beige <input type="checkbox"/> D11 Silver <input type="checkbox"/> E10 Silver charcoal <input type="checkbox"/> E20 Textured grey blue <input type="checkbox"/> G11 Textured blue <input type="checkbox"/> H11 Textured dark blue <input type="checkbox"/> H21 Textured dark turquoise <input type="checkbox"/> J11 Textured turquoise <input type="checkbox"/> J21 Textured forest green <input type="checkbox"/> K11 Textured dark forest green <input type="checkbox"/> K21 Textured dark green <input type="checkbox"/> K31 Fine textured dark green <input type="checkbox"/> K42 Textured red <input type="checkbox"/> M11 Textured burgundy <input type="checkbox"/> M21 Fine textured patina <input type="checkbox"/> X11 Custom colour <input type="checkbox"/> CC ★	Optional Button type photoelectric cell <input type="checkbox"/> PB

- ▲ Use ED-18 bulb type
- Use ED-28 bulb type
- ★ Consult manufacturer

IMPORTANT NOTICE
 Éclairage SDL inc. disclaims any responsibility for problems that could occur from a combination of third party products with those of Éclairage SDL inc.

Order example	44F	-	RD3	-	175H	-	120	-	A11	-	PB
	Model		Distribution		Wattage		Voltage		Colour		Other components