

Seating Pricing and Specification Guide

Price Guide - U.S. Prices effective November 2008



Humanscale designs and manufactures products for the workplace that directly impact the user's health and comfort.

Since our founding in 1983, we have held the belief that design based on functionality and ease of use results in honest and enduring forms.

Other Humanscale price guides also available:



For the most updated information on available Humanscale products, please visit www.humanscale.com

Table of Contents

Humanscale and the Environment	2
--------------------------------	---

Liberty[®]

Features & Characteristics	4
Options & Prices	6
Specifications	10
Build Your Product Code	11

freedom[®]

Features & Characteristics	12
Options & Prices	14
Specifications	18
Build Your Product Code	20

cinto[™]

Features & Characteristics	22
Specifications	23
Options & Prices	24
Build Your Product Code	25

Textiles	26
Terms & Conditions	30

Humanscale and the Environment

Humanscale is committed to environmental sustainability and continually strives to design, engineer and manufacture products that—compared to others in the same class—consume less of the Earth’s limited resources.

In addition to supporting sustainability through superior design, Humanscale is a major contributor to and maintains an active partnership with World Wildlife Fund.

LEED® Credit

All Humanscale seating is Greenguard-Certified and can help a project achieve LEED certification in a number of areas. Consult your Humanscale representative for additional information on earning any of the LEED credits detailed here.

ID Credit 1.1 – 1.4 — Innovation in Design: Ergonomic Strategy

MR Credit 2.1 — Construction Waste Management, 50%

MR Credit 2.2 — Construction Waste Management, 75%

MR Credit 3.3 — Resource Reuse

MR Credit 4.1 — Recycled Content, 10%

MR Credit 4.2 — Recycled Content, 20%

MR Credit 5.1 — Regional Materials, 20% *Must be delivered within 500 miles of Piscataway, NJ (Freedom, Liberty) or 500 miles of Fresno, CA (Cinto)*

EQ Credit 4.5 — Low-Emitting Materials

This brochure is printed in the USA on Finch Fine paper certified by Smartwood as a well-managed source of wood products whose forest management practices adhere to strict environmental and socioeconomic standards in accordance with the criteria of the Forest Stewardship Council (FSC). Smartwood is a program of the Rainforest Alliance.



Proud Supporter of:



Freedom's Environmental Highlights

- Made predominantly of aluminum, followed by steel and plastic
- Contains 62% recycled content (43% post-consumer, 19% pre-consumer)
- 90% recyclable
- Weighs only 35 lbs.
- Made of 132 parts (comparable chairs are made of up to 250 parts)
- Modular cushions for easy replacement
- Designed for easy disassembly
- Ships in 85% recycled packaging or blanket-wrapped when feasible
- Greenguard Certified

Liberty's Environmental Highlights

- Made predominantly of aluminum, followed by steel and plastic
- Contains 54% recycled content (32% post-consumer, 22% pre-consumer)
- 93% recyclable
- Weighs only 27 lbs.
- Modular cushions for easy replacement
- Designed for easy disassembly
- Ships in 85% recycled packaging or blanket-wrapped when feasible
- Greenguard Certified

Cinto's Environmental Highlights

- Constructed of a steel tube frame, elastomer belt, and injection-molded polypropylene
- Contains 26% recycled content (15% post-consumer, 11% pre-consumer)
- 100% recyclable
- Seat pan, arms, glides and casters are easily replaceable if broken or damaged
- Designed for easy disassembly
- Ships in 85% recycled packaging or blanket-wrapped when feasible
- Humanscale will assist the owner to ensure the chair is recycled properly
- Greenguard Certified

Liberty® Features & Characteristics

Liberty, with Form-Sensing Mesh Technology, is unlike any mesh chair you've seen or experienced. With its tri-panel construction, Liberty has the body-fitting contours that single-panel stretch mesh chairs simply can't achieve. And it offers perfect lumbar support for everyone, without external devices or manual adjustments. Liberty's mesh back is formed by combining three panels of non-stretch mesh in the same way a tailor combines multiple pieces of material to form a shirt. So its contours are custom-made to both fit and support the human body in unprecedented comfort.



PHYSICAL CHARACTERISTICS

CUSHIONS

- Non-stretch, tri-panel mesh back
- Molded polyurethane foam seat cushion
- Duron arm pads
- Optional arm pads and seats have top layer of Technogel®
- Seats upholstered with a variety of materials customized to the unique form of the cushion

CUSHION PAN, BACK FRAME, FIVE-ARM BASE

- Injection-molded, structural, integral color plastics
- Optional stainless steel caps on base

EXTERNAL FRAME

- Die-cast aluminum with fused plastic coating or polished aluminum finish

STORED ENERGY DEVICES

- Nitrogen-charged gas cylinder for adjustable seat height
- Coil spring in the self-adjusting recline mechanism
- Torsion spring in the pivoting backrest

OPTIONAL FOOT RING

- Chrome-plated steel

STANDARD FEATURES

SELF-ADJUSTING RECLINE

- Intelligent counter-balance recline mechanism automatically provides the right amount of support through the full range of recline motion, regardless of user size and weight
- No tension springs to adjust
- No recline locks to set/release
- During recline, the angle between torso and legs opens up for better body function
- User maintains near-constant eye level during recline

PIVOTING BACKREST

- Extra motion of the backrest during recline automatically adjusts to the changing needs of the spine
- Provides additional lumbar support as needed

FORM-SENSING MESH

- Tri-panel, non-stretch mesh construction creates body-fitting contours and self-adjusting lumbar support for a customized fit
- No external lumbar devices to adjust, break or lose
- Low-abrasion mesh protects clothing
- Modular for easy replacement

STANDARD CYLINDER

- Provides seat height range that accommodates 95% of the population

CONTOURED SEAT CUSHION

- Carefully sculpted to match body contours
- Increased contact area reduces pressure points
- Modular for easy replacement

BODY FIT

- Size adjustable to fit more than 95% of the population
- Form-sensing mesh provides perfect lumbar support—automatically
- Manual adjustments for fit-to-size:
 - Seat Height: 5" adjustment range
 - Seat Depth: 2.25" adjustment range

CASTERS

- 3" dual-surface casters roll easily on carpeted floors and quietly on hard floors

OPTIONAL FEATURES

ARMREST OPTIONS

- Armless
- Fixed armrests
- Height-adjustable armrests with 5" range of adjustment

GEL SEAT CUSHION

- Non-degradable, non-compressible Technogel® layer on top of foam core
- Provides maximum pressure distribution
- Offers unmatched long-term comfort

ARM PAD OPTIONS

- Flexible Duron
- Technogel® for optimal comfort

CYLINDER OPTIONS

- Low cylinder for small users
- Tall cylinder for very tall users
- High cylinder with foot ring
- Return-to-height cylinder returns chair to highest position when user exits chair

FIREPROOFING

- CAL 133-approved
 - Fireproof barrier between textile and foam
 - Fire-retardant plastics

CASTER OPTIONS

- Non-rolling glides for fixed location use

POLISHED BASE CAPS

- Stainless steel caps on five-star base for wear protection and aesthetic appeal

FOOT RING

- Chrome finish
- Height-adjustable

Liberty® Options & Prices

CONFERENCE CHAIR	ARM OPTIONS	CODE
 <p>Armless</p>  <p>Fixed Arms</p>	Armless	L110
	Fixed Duron Arms	L116
	Fixed Duron Arms with Matching Textile Cover	L117
	Fixed Gel Arms with Xanium Cover	L11X
	Fixed Gel Arms with Matching Textile Cover	L11M
TASK CHAIR		
 <p>Adjustable Arms</p>	Height-Adjustable Duron Arms*	L111
	Height-Adjustable Duron Arms with Matching Textile Cover*	L112
	Height-Adjustable Gel Arms with Xanium Cover	L11D
	Height-Adjustable Gel Arms with Matching Textile Cover	L11C
SIDE CHAIR		
	Armless	L400
	Fixed Duron Arms*	L406
	Fixed Gel Arms with Xanium Cover	L40X

* Available first quarter 2009.

TEXTILE 0	TEXTILE 1	TEXTILE 2	TEXTILE 3	LEATHER 0	LEATHER 1	LEATHER 2
\$910	\$930	\$955	\$1005	\$1100	\$1340	\$1545
\$1015	\$1035	\$1060	\$1110	\$1205	\$1445	\$1650
\$1030	\$1050	\$1080	\$1135	\$1235	\$1480	\$1690
\$1045	\$1065	\$1090	\$1140	\$1235	\$1475	\$1680
\$1060	\$1080	\$1110	\$1165	\$1265	\$1510	\$1720

\$1090	\$1110	\$1135	\$1185	\$1280	\$1520	\$1725
\$1105	\$1125	\$1155	\$1210	\$1310	\$1555	\$1765
\$1120	\$1140	\$1165	\$1215	\$1310	\$1550	\$1755
\$1135	\$1155	\$1185	\$1240	\$1340	\$1585	\$1795

—	\$490	—	—	—	—	—
—	\$575	—	—	—	—	—
—	\$605	—	—	—	—	—

Liberty® Options & Prices

REPLACEMENT PARTS*	OPTIONS	CODE	
LIBERTY CONFERENCE/TASK Replacement Cushions	Seat (Foam)	LSF	1 2 2 2 —
	Seat (Gel)	LSG	1 2 2 2 —
	Mesh Backrest	LB	3 4 2 2 —
	Fixed Duron Arm Pads (Pair)	LDA	5 \$45
	Fixed Gel Arm Pads with Xanium Cover (Pair)	LGA	\$75
	Height-Adjustable Gel Arm Pads with Xanium Cover (Pair)	LGV	\$75
	Fixed Duron Arm Pads with Matching Textile (Pair)	LDAM	1 2 2 2 —
	Fixed Gel Arm Pads with Matching Textile (Pair)	LGAM	1 2 2 2 —
	Height-Adjustable Gel Arm Pads with Matching Textile (Pair)	LGVM	1 2 2 2 —
	LIBERTY SIDE CHAIR Replacement Cushions	Mesh Backrest	LSCB
Mesh Seat Cushion		LSCS	3 4 2 2 —
Duron Arm Pads (Pair)		LSDA	5 \$45
Gel Arm Pads with Xanium Cover (Pair)		LSGA	\$75
RETROFIT PARTS*	ARM OPTIONS		
LIBERTY CONFERENCE/TASK Retrofit Armrest Kits	Fixed Duron Arms (Pair)	LKFD	3 5 \$115
	Fixed Gel Arms with Xanium Cover (Pair)	LKFG	3 \$145
	Height-Adjustable Gel Arms with Xanium Cover (Pair)	LKA	3 \$190
	Fixed Duron Arms with Matching Textile (Pair)	LKFDM	3 1 2 2 2 —
	Fixed Gel Arms with Matching Textile (Pair)	LKFGM	3 1 2 2 2 —
	Height-Adjustable Gel Arms with Matching Textile (Pair)	LKAM	3 1 2 2 2 —
LIBERTY SIDE CHAIR Retrofit Armrest Kits	Fixed Duron Arms (Pair)	LSKFD	3 5 \$105
	Fixed Gel Arms with Xanium Cover (Pair)	LSKFX	3 \$135

1 – Textile Code (pages 26-28) 2 – Cushion Color (pages 26-28) 3 – Frame Color (B, V, L, A, P) 4 – Mesh (M, C, T) 5 – Arm Pad Color (S, B)
* All Liberty Replacement and Retrofit Parts are CAL 133-approved.

TEXTILE 0	TEXTILE 1	TEXTILE 2	TEXTILE 3	LEATHER 0	LEATHER 1	LEATHER 2
\$115	\$125	\$150	\$200	\$310	\$545	\$750
\$190	\$200	\$225	—	—	—	—
—	\$175	—	—	—	—	—
—	—	—	—	—	—	—
—	—	—	—	—	—	—
—	—	—	—	—	—	—
\$55	\$65	\$85	\$85	\$95	\$115	\$145
\$85	\$95	\$115	\$115	\$125	\$145	\$175
\$85	\$95	\$115	\$115	\$125	\$145	\$175
—	\$175	—	—	—	—	—
—	\$175	—	—	—	—	—
—	—	—	—	—	—	—
—	—	—	—	—	—	—
—	—	—	—	—	—	—
—	—	—	—	—	—	—
—	—	—	—	—	—	—
\$125	\$135	\$155	\$155	\$165	\$185	\$215
\$155	\$165	\$185	\$185	\$195	\$215	\$245
\$200	\$210	\$230	\$230	\$240	\$260	\$290
—	—	—	—	—	—	—
—	—	—	—	—	—	—

Liberty® Specifications

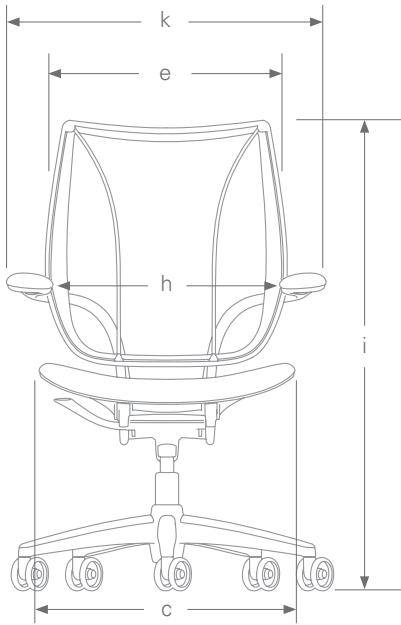

CODE	DESCRIPTION	MEASUREMENT	
		Conference/Task	Side
a	seat depth <i>(from face of lumbar to front of seat)</i>	16.5" – 18.75"	17.5"
b	seat height <i>(from floor to compressed front center of seat cushion)</i>	16" – 21" standard chair 15.25" – 19" low chair 17" – 22.25" tall chair 20.5" – 28.5" high chair with foot ring	18"
c	seat width	21"	20.75"
d	backrest height <i>(from seat cushion to top of backrest)</i>	22.5"	18.5"
e	backrest width	20"	19.75"
f	armrest height <i>(from compressed seat cushion to top of armrest)</i>	10" fixed 6.5" – 11.5" adjustable	9.5"
g	armrest length <i>(from face of lumbar to front of armrest)</i>	12.25"	12"
h	distance between armrests	19"	19.25"
i	height	38.5" – 43.5" standard chair 37.75" – 41.5" low-cylinder chair 39.5" – 44.75" tall-cylinder chair 43" – 51" high chair with foot ring	35.5"
j	base diameter	25"	N/A
k	chair width	26.5"	24.75"

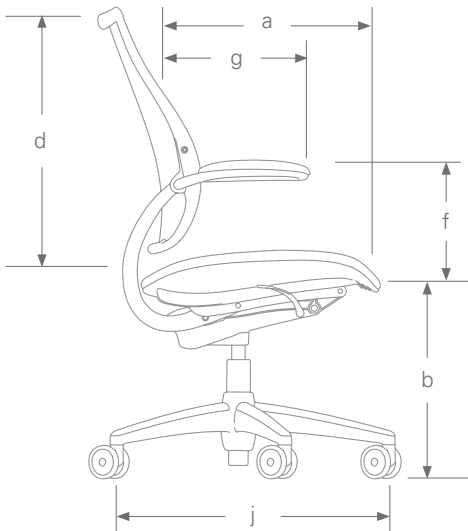

SCOPE OF USERS

- Conference/Task chair fits more than 95% of the office population
– 5'0" Woman to 6'4" Man
– 100 to 300 lbs.
- Users outside the standard range can be accommodated by Low or Tall Cylinder

WEIGHT

- 27 lbs. *Conference/Task chair*
- 15 lbs. *Side chair*

TILT AND RECLINE

- 17° recline plus 7° backrest tilt
Conference/Task chair

REFERENCE ANGLE BETWEEN SEAT AND BACK

- 100° to 124° *Conference/Task chair*

Liberty® Build Your Product Code

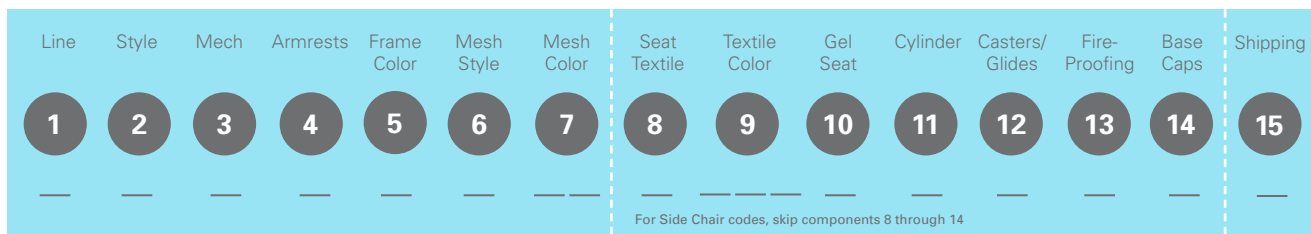

COMPONENT	CODE	DESCRIPTION	COMPONENT	CODE	DESCRIPTION
1	LINE	L Liberty	8	SEAT TEXTILE	See pages 26-28 and textile samples for textile codes.
2	STYLE	1 Conference/Task chair 4 Side chair	9	TEXTILE COLOR	See pages 26-28 and textile samples for color options and codes.
3	MECHANISM	0 Side chair 1 Conference/Task chair	10	GEL SEAT	— Standard Seat Pan G Gel Seat (Add \$74) (Available only with V, B, H, S, G or W textiles)
4	ARMRESTS	0 Armless 1 Adjustable Duron Arms*† 2 Adjustable Duron Arms with Matching Textile*† 6 Fixed Duron Arms ‡ 7 Fixed Duron Arms with Matching Textile* X Fixed Gel Arms with Xanium Cover M Fixed Gel Arms with Matching Textile* D Adjustable Gel Arms with Xanium Cover* C Adjustable Gel Arms with Matching Textile*	11	CYLINDER	— Standard 5" L Low 3.75" (Add \$26) T Tall 5" (Add \$37) F High 8" w/18" Foot Ring (Add \$110) R High 8" w/21" Foot Ring (Add \$152) E Return to Height 5" (Add \$42) Note: Silver Trim chairs ship with Polished Aluminum cylinders. Black Trim chairs ship with Black cylinders. Return to Height (E) available in Black only.
5	FRAME COLOR	B Black with Black Trim V Silver with Silver Trim L Silver with Black Trim A Polished Aluminum with Black Trim and Polished Base Caps (see pricing below) P Polished Aluminum with Silver Trim and Polished Base Caps (see pricing below) Note: Frame Color refers to all metal parts (back support, arm supports), Trim Color refers to all plastic parts (base, backrest frame, seat shell, etc.) Pricing: For A or P, add \$126 for Conference/Task chair, \$84 for Side chair	12	CASTERS/ GLIDES	— Standard 3" Casters for all surfaces G Glides
6	MESH STYLE	M Monofilament Stripe C Silver Check T Torque* See page 28 and textile samples for mesh descriptions and specifications.	13	FIRE-PROOFING	— Standard Foams and Plastics C CAL 133-Approved Foams and Plastics (Add \$42) Note: Standard Side Chair is CAL 133-approved
7	MESH COLOR	See page 28 and textile samples for mesh color options and codes.	14	BASE CAPS	— Standard Base to Match Frame Color — Polished Base Caps on Polished Aluminum Frame A Polished Base Caps on Black or Silver Frame (Add \$42)
			15	SHIPPING	— Individually Boxed B Blanket Wrapped**

* Not available on Side chair

† Available first quarter 2009

‡ Available first quarter 2009 on Side chair

** See Terms and Conditions, page 30, for minimum order requirements

freedom® Features & Characteristics

With Freedom, the knobs, levers and locks of current-generation task chairs have been replaced by intelligent mechanisms that automatically support the body as it moves from task to task. By minimizing the need for manual controls, Freedom maximizes natural, spontaneous movement, which is essential for a healthy body and a comfortable day's work. Freedom's many features can be enjoyed with virtually no effort.



PHYSICAL CHARACTERISTICS

CUSHIONS

- Molded polyurethane foam cushions
- Optional arm pads and seat have top layer of Technogel®
- Upholstered with a variety of materials customized to the unique form of the cushion

CUSHION PANS, ARMREST SUPPORTS, HEADREST FRAME AND FIVE-ARM BASE

- Injection-molded, structural, integral color plastics

EXTERNAL FRAME AND OPTIONAL BASE UPGRADE

- Die-cast aluminum with fused plastic coating or polished aluminum finish

STORED ENERGY DEVICES

- Nitrogen-charged gas cylinder for adjustable seat height
- Coil spring in the self-adjusting recline mechanism
- Elastomer spring in the pivoting backrest

OPTIONAL FOOT RING

- Chrome-plated steel ring

STANDARD FEATURES

SELF-ADJUSTING RECLINE

- Intelligent counter-balance recline mechanism automatically provides the right amount of support through the full range of recline motion, regardless of user size and weight
- No tension springs to adjust
- No recline locks to set/release
- During recline, the angle between torso and legs opens up for better body function
- User maintains near-constant eye level during recline

PIVOTING BACKREST

- Extra motion of the backrest during recline automatically adjusts to the changing needs of the spine
- Provides up to 1" additional lumbar support when needed

SYNCHRONIZED ARMRESTS

- Revolutionary armrests move in tandem to eliminate uneven arm positioning
- Natural lift and release action for immediate repositioning without buttons or locks
- 6" range of vertical motion to accommodate all users and tasks
- Can be positioned below thigh level for close table or desk work
- Attached to backrest so arms stay in same relation to body during recline
- Duron arm pad for durability and comfort

STANDARD CYLINDER

- Provides seat height range that accommodates 95% of the population

CONTOURED CUSHIONS

- Carefully sculpted to match body contours
- Increased contact area reduces pressure points
- Modular for easy replacement

BODY FIT

- Size adjustable to fit more than 95% of the population
- Adjustments for fit-to-size:
 - Headrest: 5" vertical adjustment range
 - Seat Height: 5" adjustment range
 - Seat Depth: 2.25" adjustment range
 - Backrest/Lumbar Support Height: 3" adjustment range

HARD CASTERS

- 2.5" double-wheel casters for carpeted floors

OPTIONAL FEATURES

DYNAMIC HEADREST

- Position-sensitive headrest moves into place when you recline and out of the way when you sit upright
- 5" vertical adjustment to fit all users
- Moves in the natural arc of head/neck for perfect support through range of recline
- Contoured to cradle the head and neck in comfort

GEL SEAT CUSHION

- Non-degradable, non-compressible Technogel® layer on top of foam core
- Provides maximum pressure distribution
- Offers unmatched, long-term comfort

ARM PAD OPTION

- Flexible Duron
- Technogel® for optimal comfort

ADVANCED ARMRESTS

- Pivot at elbow for width adjustment
- Lockable in 5° increments
- Automatic unlock feature when positioned inward and user wishes to exit chair
- 1.25" longer than Standard Armrests for additional forearm support

CYLINDER OPTIONS

- Low cylinder for small users
- Tall cylinder for very tall users
- High cylinder with foot ring
- Extra-high cylinder with foot ring (Saddle seat only)

FOOT RING

- Chrome finish
- Height-adjustable

CASTER OPTIONS

- 2.5" soft double-wheel casters for hard floors
- Non-rolling glides for fixed-location use
- 2.5" locking casters

FIREPROOFING

- CAL 133-approved
 - Fireproof barrier between textile and foam
 - Fire-retardant plastics

freedom® Options & Prices

TASK CHAIR



ARM OPTIONS

CODE

Armless	F110
Standard Duron Arms	F111
Standard Duron Arms with Matching Textile Cover	F112
Standard Gel Arms with Xanium Cover	F11X
Standard Gel Arms with Matching Textile Cover	F11M
Advanced Duron Arms*	F113
Advanced Duron Arms with Matching Textile Cover*	F114
Advanced Gel Arms with Xanium Cover	F11D
Advanced Gel Arms with Matching Textile Cover	F11C

TASK CHAIR WITH HEADREST



Armless	F210
Standard Duron Arms	F211
Standard Duron Arms with Matching Textile Cover	F212
Standard Gel Arms with Xanium Cover	F21X
Standard Gel Arms with Matching Textile Cover	F21M
Advanced Duron Arms*	F213
Advanced Duron Arms with Matching Textile Cover*	F214
Advanced Gel Arms with Xanium Cover	F21D
Advanced Gel Arms with Matching Textile Cover	F21C

SADDLE SEAT



F300

*Advanced Duron Arms available first quarter 2009.

TEXTILE 0	TEXTILE 1	TEXTILE 2	TEXTILE 3	LEATHER 0	LEATHER 1	LEATHER 2
\$985	\$1005	\$1060	\$1155	\$1340	\$1820	\$2225
\$1090	\$1110	\$1165	\$1260	\$1445	\$1925	\$2330
\$1105	\$1125	\$1185	\$1285	\$1475	\$1960	\$2370
\$1120	\$1140	\$1195	\$1290	\$1475	\$1955	\$2360
\$1135	\$1155	\$1215	\$1315	\$1505	\$1990	\$2400
\$1175	\$1195	\$1250	\$1345	\$1530	\$2010	\$2415
\$1190	\$1210	\$1270	\$1370	\$1560	\$2045	\$2455
\$1205	\$1225	\$1280	\$1375	\$1560	\$2040	\$2445
\$1220	\$1240	\$1300	\$1400	\$1590	\$2075	\$2485

\$1180	\$1200	\$1265	\$1370	\$1585	\$2080	\$2490
\$1285	\$1305	\$1370	\$1475	\$1690	\$2185	\$2595
\$1300	\$1320	\$1390	\$1500	\$1720	\$2220	\$2635
\$1315	\$1335	\$1400	\$1505	\$1720	\$2215	\$2625
\$1330	\$1350	\$1420	\$1530	\$1750	\$2250	\$2665
\$1370	\$1390	\$1455	\$1560	\$1775	\$2270	\$2680
\$1385	\$1405	\$1475	\$1585	\$1805	\$2305	\$2720
\$1400	\$1420	\$1485	\$1590	\$1805	\$2300	\$2710
\$1415	\$1435	\$1505	\$1615	\$1835	\$2335	\$2750

\$365	\$375	\$405	\$455	\$550	\$800	\$995
-------	-------	-------	-------	-------	-------	-------

freedom® Options & Prices

REPLACEMENT PARTS*	OPTIONS	CODE		
Replacement Cushions 	Seat (Foam)	S	1 2 2 2 F —	
	Seat (Gel)	S	1 2 2 2 G —	
	Back	B	1 2 2 2 F —	
	Saddle	L	1 2 2 2 —	
	Headrest	H	1 2 2 2 F —	
	Standard Duron Arm Pads (Pair)	FA		\$45
	Advanced Duron Arm Pads (Pair)**	FV		\$45
	Standard Gel Arm Pads with Xanium Cover (Pair)	FX		\$75
	Advanced Gel Arm Pads with Xanium Cover (Pair)	FD		\$75
	Standard Duron Arm Pads with Matching Textile (Pair)	FAM	1 2 2 2	—
	Advanced Duron Arm Pads with Matching Textile (Pair)**	FVM	1 2 2 2	—
	Standard Gel Arm Pads with Matching Textile (Pair)	FXM	1 2 2 2	—
	Advanced Gel Arm Pads with Matching Textile (Pair)	FDM	1 2 2 2	—

RETROFIT PARTS*	ARM OPTIONS		
Retrofit Armrest Kits 	Advanced Duron Arms**	KDA	3 \$180
	Advanced Gel Arms with Xanium Cover	KA	3 \$210
	Advanced Duron Arms with Matching Textile**	KDAM	3 1 2 2 2 —
	Advanced Gel Arms with Matching Textile	KAM	3 1 2 2 2 —

1 – Textile Code (pages 26-28) 2 – Cushion Color (pages 26-28) 3 – Frame/Cushion Shell Color (G=Graphite, T=Titanium)

* All Freedom Replacement and Retrofit Parts are CAL 133-approved.

**Advanced Duron Arms available first quarter 2009.

TEXTILE 0	TEXTILE 1	TEXTILE 2	TEXTILE 3	LEATHER 0	LEATHER 1	LEATHER 2
\$115	\$125	\$150	\$200	\$310	\$545	\$750
\$190	\$200	\$225	—	—	—	—
\$115	\$125	\$150	\$200	\$310	\$545	\$750
\$130	\$140	\$190	\$235	\$340	\$580	\$790
\$100	\$110	\$120	\$140	\$165	\$235	\$300
—	—	—	—	—	—	—
—	—	—	—	—	—	—
—	—	—	—	—	—	—
—	—	—	—	—	—	—
\$55	\$65	\$85	\$85	\$95	\$115	\$145
\$55	\$65	\$85	\$85	\$95	\$115	\$145
\$85	\$95	\$115	\$115	\$125	\$145	\$175
\$85	\$95	\$115	\$115	\$125	\$145	\$175

—	—	—	—	—	—	—
—	—	—	—	—	—	—
\$190	\$200	\$210	\$210	\$220	\$245	\$280
\$220	\$230	\$240	\$240	\$250	\$275	\$310

freedom[®] Specifications

TASK CHAIR

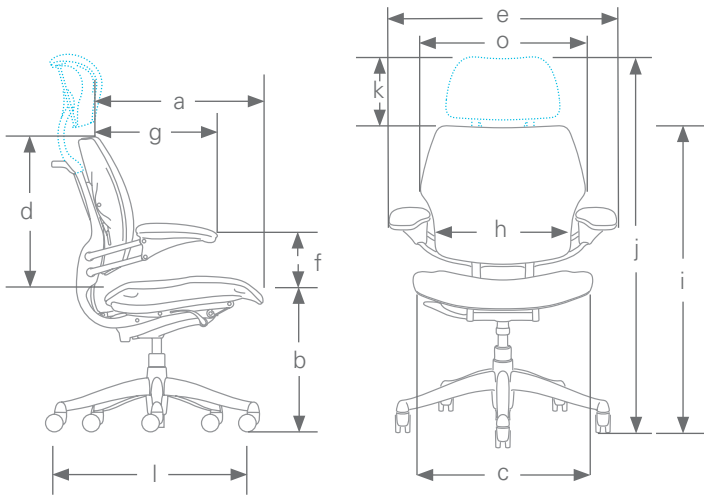

SCOPE OF USERS

- Standard chair fits more than 95% of the office population
 - 5'0" Woman to 6'4" Man
 - 100 to 300 lbs.
- Users outside the standard range can be accommodated by
 - Low or Tall Cylinder
 - Advanced Armrests

WEIGHT

- 35 lbs. Standard Chair
- 39 lbs. Chair with Headrest
- 19 lbs. Saddle with Foot Ring

BACKREST RECLINE

- 22° recline plus 7° backrest tilt

REFERENCE ANGLE BETWEEN SEAT AND BACK

- 100° to 129°

SADDLE SEAT

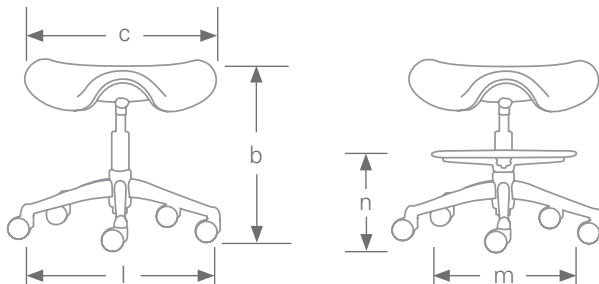

ADVANCED TASK ARMRESTS

- Horizontal angle change from elbow pivot point
 - 35° each armrest
 - Lockable in 5° increments

HEADREST RADIAL MOTION

(automatic motion during recline)

- 30°

LUMBAR SUPPORT INCREASE IN RECLINE

- 1"

CODE	DESCRIPTION	MEASUREMENT
a	seat depth <i>(from face of lumbar to front of seat)</i>	16.25" – 18.5"
b	seat height <i>(floor to compressed front center of seat cushion)</i>	16" – 21" standard chair 15.25" – 19" low-cylinder chair 17" – 22.25" tall-cylinder chair 20.5" – 28.5" high-cylinder chair 17.5" – 22.75" standard Saddle seat 20.25" – 28.25" high Saddle seat 23" – 33" extra-high Saddle seat
c	seat width	21" chair 22" Saddle seat
d	backrest height <i>(from seat cushion to top of backrest)</i> – adjustment range	18" – 21" 3" in 0.25" increments
e	chair width	27.25"
f	armrest height <i>(compressed seat cushion to top of armrest)</i> – adjustment range	5" – 11" 6" in 0.33" increments
g	armrest length <i>(from face of lumbar to front of armrest)</i>	13" standard 14.25" advanced
h	distance between armrests <i>(front inside edge)</i>	20" standard 11.5" – 21.5" advanced
i	height, task chair	33.5" – 41.5" standard chair 32.75" – 39.5" low-cylinder chair 34.5" – 42.75" tall-cylinder chair 38" – 49" high-cylinder chair
j	height, task chair with headrest	43" – 53" standard chair 42.25" – 51" low-cylinder chair 44" – 54.25" tall-cylinder chair 47.5" – 60.5" high-cylinder chair
k	headrest height adjustment range	5"
l	base diameter	25" chair, high or extra-high Saddle seat 22" standard Saddle seat
m	foot ring diameter	18" or 21"
n	foot ring height adjustment <i>(from floor)</i>	6" – 11"
o	backrest width	21"

freedom® Build Your Product Code



COMPONENT	CODE	DESCRIPTION	COMPONENT	CODE	DESCRIPTION
1 LINE	F	Freedom	8 GEL SEAT	— G ¹	Standard Foam Seat Pan Gel Seat (Add \$74) <i>(Available only with V, B, H, S, G or W textiles)</i>
2 STYLE	1 2 3	Standard Task Chair Task Chair with Headrest Saddle Seat	9 CYLINDER	— L ¹ T H ² F R X ^{2,3} Z ^{2,3}	Standard 5" Low 3.75" (Add \$26) Tall 5" (Add \$37) High 8" (Add \$37) High 8" w/18" Foot Ring (Add \$110) High 8" w/21" Foot Ring (Add \$152) Extra-High 10" w/18" Foot Ring (Add \$110) Extra-High 10" w/21" Foot Ring (Add \$152) <i>Note: Polished Aluminum chairs ship with Polished cylinders. Graphite and Titanium chairs ship with Black cylinders. Extra-high (X, Z) available in Black only.</i>
3 MECHANISM	1 0	Standard Saddle Seat	10 CASTERS	— S G K	Standard Hard Casters Soft Casters (Add \$21) Glides (Add \$21) Locking Casters (Add \$110)
4 ARMRESTS	0 1 2 3 4 X M D C	Armless <i>(Required option for Saddle Seat)</i> Standard Duron Arms Standard Duron Arms with Matching Textile Advanced Duron Arms* Advanced Duron Arms with Matching Textile* Standard Gel Arms with Xanium Cover Standard Gel Arms with Matching Textile Advanced Gel Arms with Xanium Cover Advanced Gel Arms with Matching Textile	11 FIRE-PROOFING	— C	Standard Foams and Plastics CAL 133-Approved Foams and Plastics (Add \$74 for Task Chair with Headrest, \$58 for Standard Task Chair, \$32 for Saddle Seat)
5 FRAME COLOR	G T A M	Graphite Titanium Polished Aluminum with Graphite shells on cushions and armrests** <i>(see pricing below)</i> Polished Aluminum with Titanium shells on cushions and armrests** <i>(see pricing below)</i> <i>Pricing: For A or M, add \$245 for Task Chair with Headrest, \$225 for Standard Task Chair, \$130 for Saddle Seat</i>	12 BASE UPGRADE	— — M A	Standard Plastic Base to match G or T frame color Standard Aluminum Base base to match A or M frame color Powder-coated Aluminum Base to match G or T frame color (Add \$45) Polished Aluminum Base on Graphite or Titanium Frame (Add \$130)
6 TEXTILE		<i>See pages 26-28 and textile samples for textile codes.</i>	13 SHIPPING	— B	Individually Boxed Blanket Wrapped ⁴
7 TEXTILE COLOR		<i>See pages 26-28 and textile samples for color options and codes.</i>			

¹ Not available on Saddle Seat, ² Only available on Saddle Seat, ³ Requires Glides or Locking Casters, ⁴ See Terms and Conditions, page 30, for minimum order requirements *Advanced Duron Arms available first quarter 2009 **Comes standard with polished aluminum base.

Civilization advances by the number
of important operations which we can
perform without thinking about them.

—Alfred North Whitehead

cinto™ Features & Characteristics

Appropriate for a wide range of commercial and residential environments, Cinto sets a new standard for ergonomic stackable seating through unique design and manufacturing innovations. Spanish for “belt,” Cinto features a floating backrest that is attached to the chair’s frame via a flexible belt, allowing it to move with the body to provide recline and automatic lumbar support. Stress-relief cross-slits on Cinto’s seat pan flex independently under the sitting bones to evenly distribute body weight and reduce pressure points, while air vents on the backrest and seat pan enable air circulation for cool seated comfort.



PHYSICAL CHARACTERISTICS

SEAT PAN, BACKREST

- Injection-molded polypropylene

ARM PAD

- Polyethylene

FRAME

- Steel tube

BELT

- Elastomer

STANDARD FEATURES

FLEXIBLE BACKREST

- Attached to the chair’s frame via a flexible belt, the floating backrest bends and adjusts with the sitter
- Flexibility of backrest creates virtual pivot point for automatic lumbar support
- No adjustments required

STRESS-RELIEF CROSS-SLITS

- Seat pan cross-slits flex independently under the sitting bones for even weight distribution and reduced pressure points

VENTED SEAT PAN AND BACKREST

- Promotes air circulation and prevents “hot spots”

STACKABILITY

- Freestanding Cintos stack six chairs high
- Up to 15 chairs can be stacked on the optional Cinto Dolly

BACKREST HANDLE

- Provides easy transport

LOW MAINTENANCE

- Washable with soap and water

OPTIONAL FEATURES

ARMREST OPTIONS

- Armless
- Fixed arms

FRAME OPTIONS

- Silver
- Black

BASE OPTIONS

- Sled base*
- Four legs on glides
- Four legs on casters

COLOR OPTIONS

- White with Gray Belt
- Black with Black Belt
- Gray with Gray Belt
- Taupe with Gray Belt
- Light Gray with Gray Belt
- Yellow with Gray Belt
- Green with Gray Belt
- Light Blue with Gray Belt
- Blue with Gray Belt
- Red with Gray Belt

FIREPROOFING

- CAL 133-approved

SPECIFICATIONS

SCOPE OF USERS

- Weight capacity: 300 lbs.



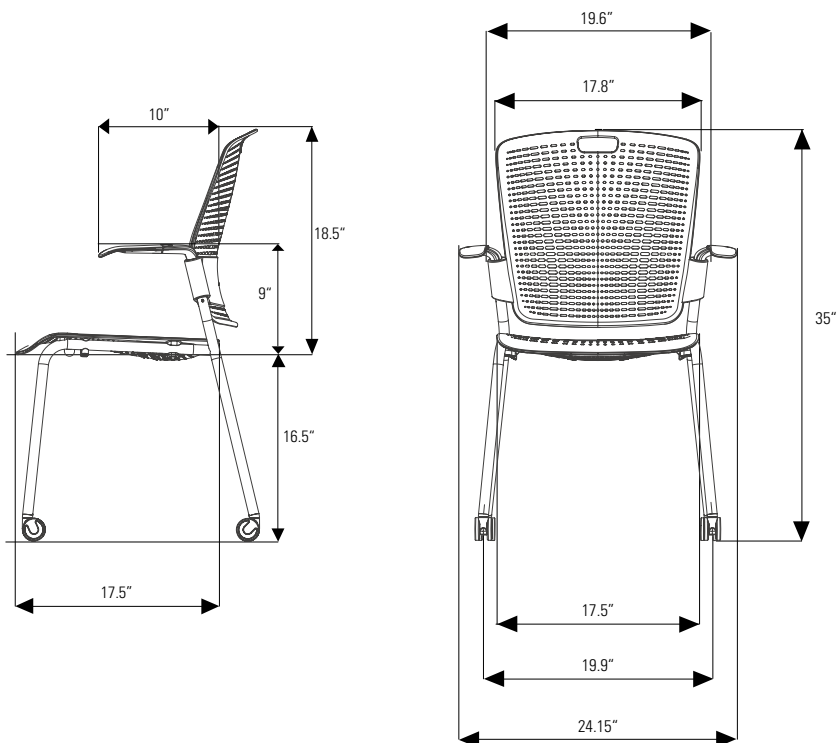

WEIGHT

- 12 lbs. Armless chair
- 13 lbs. Fixed-Arm chair



*Sled base available fourth quarter 2008.

cinto™ Options & Prices

ARMLESS STACKING CHAIR	OPTIONS	CODE	LIST PRICE
	Four Legs/Glides	C10	\$215
	Four Legs/Casters	C20	\$245
	Sled Base	C30	\$255
 	Four Legs/Glides	C15	\$265
	Four Legs/Casters	C25	\$295
	Sled Base	C35	\$305
CINTO DOLLY 	Cinto Dolly	CINTODLY	\$230
REPLACEMENT/RETROFIT PARTS	OPTIONS	CODE	LIST PRICE
	Seat Pan	CRS 1 1	\$50
	Seat Pan, CAL 133-Approved	CRS 1 1 C	\$60
	Casters (Black, Set of 4)	CRCAST	\$30
	Glides (Set of 4)	CRGLIDE 2	\$10
	Arm Sleeves (Pair)	CRA 3	\$26
	Retrofit Armrest Kit (Pair)	CKA 2 3	\$75

1 – Backrest, Seat Pan Color (page 25)
 2 – Frame Color (S = Silver, B = Black)
 3 – Trim Color (G = Gray, B = Black)

cinto™ Build Your Product Code



COMPONENT	CODE	DESCRIPTION
1 LINE	C	Cinto (Base price \$215)
2 STYLE	1 2 3	Four Legs, Glides Four Legs, Casters (Add \$30) Sled Base (Add \$40)
3 ARMRESTS	0 5	Armless Fixed Arms (Add \$50)
4 FRAME COLOR	S B	Silver Black
5 BACKREST, SEAT PAN COLOR	01 10 15 17 18 33 41 52 53 72	White Black Gray Taupe Light Gray Yellow Green Light Blue Blue Red
<i>Note: Belt is black on Black chairs, gray on all other colors.</i>		
6 UPGRADES	— C	Standard Plastics CAL 133-Approved (Add \$20)

Textiles

TEXTILE

The cushions on all Humanscale chairs utilize advanced technology developed primarily for the sportswear and sporting goods industries. In a single step, a high-tech molding process combines the textile, foam or Technogel®, and plastic support shell into a single, modular unit which can be attached to our seating with four screws. Because of this advanced process, the textiles used on the cushions are as unique as the rest of the chair, and satisfy requirements more demanding than typical upholstery textiles.

WAVE

Textile Code: W **Textile Grade: 1**
Developed initially for sportswear, Wave responds to the unique form and production requirements of Humanscale seating. This four-way stretch fabric exceeds all contract interior testing requirements for heavy-duty upholstery. The colors of Wave are taken from the phenomenal hues found in nature.

Colors:
101 Black
102 Graphite
104 Smoke
201 Dark Brown
213 Rattan
402 Loden
415 Sage
502 Blue
507 Navy
601 Ultraviolet
714 Poppy
803 Cayenne

SENSUEDE

Textile Code: D **Textile Grade: 3**
Offering style and performance, Sensuede was developed to be the best and most luxurious engineered suede available. The silky feel is the result of recycled microfibers that are breathable, extra-strong, and resistant to most stains and wrinkles.

Colors:
111 Ebony
115 Pewter
208 Chocolate
305 Goldenrod
406 Olive
411 Pear
413 Arbor
512 Denim
517 Persian
709 Pampas
712 Oxblood

VELLUM

Textile Code: V **Textile Grade: 1**
Constructed of a simple weave using a blend of nylon, Cordura and elastic yarn, this textile offers a pleasing texture and extreme durability. Because of the Cordura content, this four-way stretch woven textile performs to the rigors of the most demanding environments. The color palette includes brights, classics, and neutrals.

Colors:
101 Black
102 Graphite
106 Ash
114 Light Gray
202 Seal
211 Beech
212 Mahogany
404 Moss
407 Grass
414 Greenwood
507 Navy
607 Periwinkle
713 Pomegranate

SPIRIT MILLENNIUM

Textile Code: U **Textile Grade: 1**
An anti-microbial and wipeable textile manufactured by Naugahyde, this textile is designed for use in healthcare, education, hospitality, and other environments that require surfaces to be durable and easy to maintain. It passes healthcare testing, such as anti-microbial and cleanability tests, and meets fire code requirements.

Colors:
101 Black
112 Greystone
113 Gunmetal
210 Putty
304 Golden Corn
412 Artichoke
514 Dutch Blue
515 Wedgewood
516 Royal
608 Crocus
711 Raspberry
802 Mandarin Orange

BRIDGET STRIPE

Textile Codes: Textile Grade: 2

Vertical: B

Horizontal: H

Composed primarily of renewable merino wool, Bridget Stripe offers a five-color 50-stripe pattern with shifting color sequence that creates an undisrupted movement across the surface of the fabric. Boasting exceptional durability for a wool textile, Bridget Stripe may be applied either horizontally or vertically to Humanscale seating.

Colors:

104	Smoke
266	Kohl
267	Flax
529	Midnight
732	Carmine

SQUIGGLE

Textile Codes: Textile Grade: 0

Vertical: S

Horizontal: G

Composed of 100% recycled polyester, Squiggle offers an innovative weave structure to create a modern organic wave pattern resembling ripples of water. This environmentally sound textile may be applied either horizontally or vertically to Humanscale seating.

Colors:

106	Ash
208	Chocolate
262	Sand
275	Espresso
448	Herb
501	Indigo
507	Navy
735	Cinnabar
811	Tangerine

PROMESSA

Textile Code: E Textile Grade: 3

This Ultraleather textile from Ultrafabrics is environmentally friendly, wipeable and antimicrobial, and ideally suited to healthcare, hospitality and industrial applications. Made without PVC, Promessa has a pebbled, highly textured finish that will work beautifully in a wide variety of environments.

Colors:

111	Ebony
139	Snow
157	Dewdrop
158	Shale
215	Horsehair
219	Fields
229	Briarwood
222	Pearl
223	Parchment
224	Cashmere
245	Bronze
255	Leather
290	Woodpecker
291	Cocoa
292	Tusk
306	Linen
310	Sun Shower
428	Loden
429	Hunter
441	Moss
451	Lily Pad
527	Aquamarine
518	Atlantic
611	Merlot
722	Dogwood

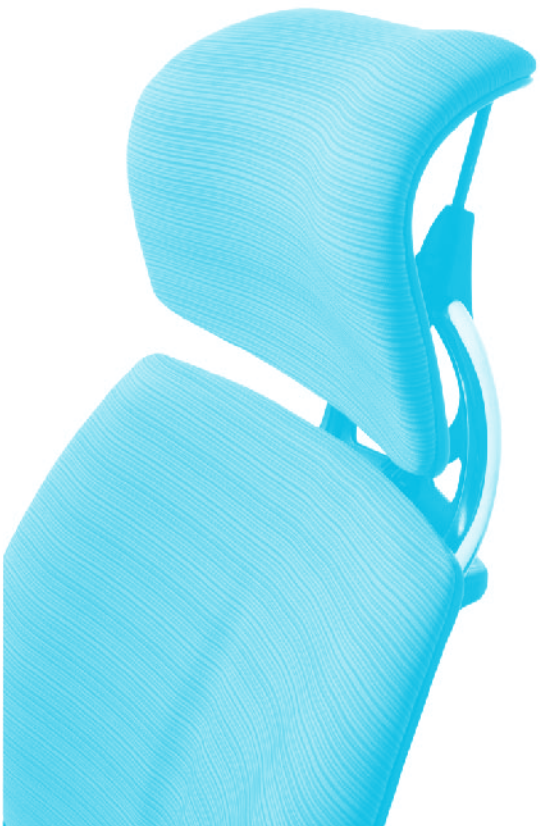

Textiles

SPINNEYBECK LEATHER

VICENZA

Textile Code: Z **Leather Grade: 0**
A lightly corrected, aniline-dyed leather produced from European hides, Vicenza receives a special retannage which enriches the leather and tightens the grain. A breathable protective finish offers durability and comfort.

Colors:
101 Black
201 Dark Brown
214 Saddle
506 Night Blue

PRIMA

Textile Code: P **Leather Grade: 2**
Prima signifies the ultimate in full-grain leather. Old world craft combined with premium select raw material create a leather in a class by itself.

Colors:
101 Black
205 Bernini
511 Giotto
609 Bramante
708 Scarlatti

SABRINA

Textile Code: L **Leather Grade: 1**
Sabrina is one of Spinneybeck's most popular full-grain leathers, offering a smooth, tight grain and suppleness of hand. It is the favorite of those seeking an elegant, fine-grained leather for high-traffic use.

Colors:
101 Black
203 Grey Beige
206 Bone
207 Nutmeg
408 Cat's Eye
508 Marine Blue
509 Water Sapphire
710 Rhubarb

MESH

These transparent textiles were created to provide optimal ergonomic support and comfort by melding strength, flexibility and resiliency. They surpass the performance criteria for contract seating textiles and meet a variety of environmental standards in both the United States and Europe, while remaining gentle on clothing.

MONOFILAMENT STRIPE

Mesh Code: M
Using only monofilament yarns that are thin and strong, a simple but classic stripe pattern is achieved through weave structure and yarn placement. This pattern has slight elasticity but terrific memory.

Colors:
10 Black
11 Carbon
14 Platinum
41 Green
51 Atlantic
81 Amber

TORQUE*

Mesh Code: T
This proven weave construction gives the look of a solid yet translucent textile. Originally developed as a protective layer for motorcycle riders, Torque is woven with nylon, polyester and urethane yarns. It is both unique and durable.

Colors:
10 Black
13 Aluminum
31 Soleil
61 Lagoon

SILVER CHECK

Mesh Code: C
This unique translucent pattern is achieved using monofilament and a silver-plated yarn spun with polyester at its core. More than simply an aesthetic choice, the silver-plated yarn gives the textile flexibility and strength.

Colors:
12 Alloy
32 Topaz
62 Sapphire
71 Ruby

**Not available on Liberty Side chair*

CUSTOM COLORS

Textiles – Most Humanscale textiles are available in any customer-specified color. Delivery time frames for custom color orders will depend on color approval. A surcharge of \$200 will apply to custom color orders of 100 or more chairs, and a surcharge of \$350 will apply to custom color orders of less than 100 chairs. The following minimums are required for custom textile colors.

Vellum: 50-chair minimum (Freedom)
100-chair minimum (Liberty)

Wave: 175-chair minimum (Freedom)
350-chair minimum (Liberty)

Torque: 110-chair minimum

Non-Stocked Colors – Vicenza, Sabrina and Prima leathers, Sensuede, Spirit Millennium, and Promessa can be ordered in any color standard to these textile lines, even if it isn't stocked by Humanscale. Ordering any non-stocked color may impact the lead time for delivery. The list price upcharge for these non-stocked colors is as follows:

Sensuede, Spirit Millennium,	\$30 per chair (Freedom)
Promessa	\$20 per chair (Liberty)

Vicenza, Sabrina, Prima: No upcharge

TEXTILE PURCHASE PROGRAM

All Humanscale textiles (with the exception of Leather, Sensuede, Promessa and Spirit Millennium) are available for purchase by the linear yard. The prices below are net (standard discounts do not apply). A \$20 cut charge will apply to each order. Please see your Humanscale representative for more information.

Wave	\$35/yd (61" width)
Monofilament Stripe	\$60/yd (50" width)
Vellum	\$45/yd (50" width)
Silver Check	\$70/yd (53" width)
Torque	\$70/yd (57" width)
Squiggle	\$25/yd (54" width)
Bridget Stripe	\$55/yd (55" width)



Humanscale Terms and Conditions

THE FOLLOWING TERMS & CONDITIONS APPLY TO ALL HUMANSCALE PRODUCTS.

TERMS OF PAYMENT

Upon approved credit, terms of payment are net 30 from date of shipment. Deposits may be required for large or custom orders. The processing of orders and/or shipment of orders placed may be delayed if the deposit is not received with the order or if customer's account is in "Past Due" status.

CREDIT POLICY

All customers of Humanscale must complete a credit application, with current information, which must be signed by an owner or officer. A line of credit may be set by our Credit Department, however the basis for the line of credit may be changed or cancelled at our discretion and advance payment may be required. Any unpaid balance, upon which payments are not made according to the terms governing the sale, will be considered "Past Due" and will increase by a maximum of 2% per month, without forfeit of Humanscale's right to payment.

Any customer who has failed to pay for goods delivered or services rendered in a timely manner shall be liable for all fees, expenses, disbursements, and charges (including all legal costs) incurred by Humanscale in collecting monies owed, as well as interest (at 24% per annum).

PURCHASE ORDERS

Purchase orders must include the following: "Bill To" and "Ship To" information—Company Name (Ship To company may be end user or installation company), Address, Telephone, Fax, Contact Person; End User Company Name; Requested Ship Date; Purchase Order Number; Special Delivery, Shipping and Packing Instructions (if applicable); Proper Discount Off Current List Price, Product Quantities and Full Model Numbers; and Total (List/Net).

ORDER CHANGES & CANCELLATIONS

All changes to or cancellations of orders placed with Humanscale must be in writing and sent to Customer Service. Orders may be changed or cancelled without penalty if Humanscale is notified at least two (2) weeks before the scheduled ship date. All order changes or cancellations made less than two (2) weeks before the scheduled ship date will incur a minimum change/cancellation fee of 10% of net. Irrespective of when notified, changes or cancellations are not binding upon Humanscale until Humanscale issues a written acknowledgment of the change or cancellation. Order changes are defined as the deletion of line items; changes in style, color, quantity or requested ship date; or ship-to address changes. Order changes that result in a quantity reduction may be subject to an additional small order fee or adjustment in pricing. Under no circumstances will changes or cancellations be accepted on any custom fabric, special order or custom product orders.

TAXES

Humanscale list prices do not include sales tax. Customer is responsible to remit all such tax. Humanscale requires a State Resale/Exemption Certification to be on file at its main office. Sales made without said Certificate will be charged the appropriate sales tax.

PRICES

All discounts and list prices are subject to change without notice. Prices are those in effect at the time of order entry. If the requested shipment date is more than 90 days after the order date, Humanscale reserves the right to price said order based on the published list price as of the shipment date.

SMALL ORDER FEE

A 3% small order fee applies to all invoiceable orders of \$1,500 net or less, including billable replacement parts, regardless of product category.

SHIPPING AND DELIVERY

All Humanscale orders are acknowledged with a promise date (scheduled ship date) based on the product with the longest lead time. Large orders may increase standard lead times. Standard shipping charges will be billed to customer. Custom platform orders require 4 to 6 weeks.

Seating orders, unless otherwise specified, will ship 4 to 6 weeks from the date of order. Unless otherwise contractually specified, Freedom and Liberty chairs will ship with the base and frame disassembled. Chairs can be easily assembled in seconds without use of tools. Blanket-wrapped shipping is available for full truckloads of 200 or more Freedom or Liberty Task and Conference chairs. Consult your Humanscale representative for blanket-wrapped shipping requirement for Cinto and the Liberty Side chair.

Ship Sets: All products ordered on a single purchase order will be delivered together in a single ship set. To break a ship set, customers must indicate "Ship as Available" on the purchase order. Upon request, customer accounts may be defaulted to ship all orders on an as-available basis.

Shipping Instructions: Humanscale will attempt to accommodate basic shipping instructions, such as "call ahead" or "deliver before 12:00 p.m.," if clearly identified on the purchase order as "Shipping Instructions."

Packing Instructions: Humanscale will attempt to accommodate basic packing instructions for internal delivery of specific items on an order, such as "Deliver to Joe Smith" or "Deliver to cube #218," if clearly identified on the purchase order as "Packing Instructions."

DELIVERY SHORTAGES

Product shortages must be noted at the time of delivery and reported to the carrier for correction. Claims against Humanscale for shortages, errors, etc., must be made in writing and within three (3) days of the date of delivery or customer waives its right to make such a claim.

FREIGHT CLAIMS

Humanscale will file all F.O.B. destination claims. In order to receive credit, customer agrees to cooperate and assist in the procedures set out by the carrier and Humanscale.

EXTERNAL DAMAGE

If the shipping container shows any external damage, customer is instructed to refuse the product at time of delivery. If it is a multiple piece shipment, customer may refuse only the damaged items. Humanscale will not issue full credit for returned product unless customer takes the following action steps:

1. Note damage on the delivery receipt at time of delivery.
2. Refuse product at time of delivery.
3. Contact Humanscale Customer Service within 24 hours of the attempted delivery and advise them of the damage.
4. Enter a chargeable replacement order; credit will be issued after the disposition of damaged product is determined.

CONCEALED DAMAGE/LOSS

If customer determines that there is internal damage not visible at time of delivery, customer will retain all packaging materials and take the following action steps within fifteen (15) calendar days from the date of delivery:

1. Request inspection by calling local freight carrier to report damage.
2. Retain merchandise in the original box.
3. Call your Humanscale Customer Service agent to provide order and product information.
4. Get a copy of the inspection report from carrier.
5. Enter a chargeable replacement order; credit will be issued after the disposition of damaged product is determined.

STORAGE

If a customer is unable to accept a scheduled product delivery, Humanscale, if notified in writing after product assembly and prior to the scheduled ship date, will store the product at customer's expense. Humanscale shall invoice customer for the product and monthly Storage Fees.

Storage Fees will be 1% of the net order value per month or actual storage costs—which ever is greater. Storage Fees are calculated with a one-month minimum and will not be pro-rated. If customer is unable to accept a scheduled product upon delivery, customer shall be responsible for placing the product in storage and bears the risk of loss. However, payment of the balance due is per Humanscale's Terms of Payment.

RETURN AUTHORIZATIONS & REFUSALS

All returned and non-damaged refused orders are subject to a twenty percent (20%) restocking fee. Seating and special order returns will not be accepted. Customer must request a Return Authorization through the Humanscale Customer Service Department within 45 days of product receipt to return any product. If Humanscale agrees to restock the product, customer must return it freight prepaid to Humanscale, F.O.B., to the original shipping point or as otherwise instructed by Humanscale Customer Service. If product is returned without a Return Authorization, Humanscale will notify customer of the unauthorized return and customer must provide instructions for its disposition within one week thereafter. Failure of customer to respond within one week will result in Humanscale's right to dispose of the product with no credit. Return Authorizations expire sixty (60) days after the date of issue. If the returned product is not in resalable condition, customer will not receive credit for the return. Customer must promptly provide a purchase order or other acceptance of fees/credit reduction as required.

WARRANTY

THE FOLLOWING WARRANTY IS IN LIEU OF ALL OTHER WARRANTIES EXPRESS OR IMPLIED, INCLUDING, BUT NOT LIMITED TO, THE IMPLIED WARRANTY OF MERCHANTABILITY AND FITNESS FOR A PARTICULAR PURPOSE AND ALL OTHER WARRANTIES ARISING FROM COURSE OF DEALING OR USAGE OF TRADE.

Humanscale offers the following warranties on its products:

PRODUCT	WARRANTY
Light Bulbs Customer's Own Material (COM, COL)	No Warranty
Switch Mouse	1 Year
Diffrient Light Fabric/Cushions	5 Years
M4 & M7 Monitor Arms with Gas Cylinder Components	10 Years
All Other Products, Detailed in a Current Price Guide	15 Years
All Other Products, Not Detailed in a Current Price Guide	Varies; consult your Humanscale rep for details

This Warranty is applicable to the initial purchaser only and is non-transferable. If products are procured through authorized Humanscale Dealerships, the end-user customer must be registered with Humanscale for the warranty to be in effect. Humanscale warrants that, at the time of customer's receipt, the product will be in good working order and will be free from defects in material and workmanship. This Warranty does not apply to normal wear and tear or damage caused by accident, neglect, misuse or improper installation or operation. Humanscale will not be responsible for damage due to service, maintenance, modifications or tampering by anyone other than a Humanscale authorized representative. In the event a product is defective and Humanscale receives written notice of the defect within the Warranty period, Humanscale, at its option, will either repair or replace the defective product. This Warranty does not cover damage caused by a carrier or transportation of the product from one location to another, or alterations made by owner.

LIMITATION OF LIABILITY

Purchaser's remedies set forth herein are exclusive and the liability of Humanscale with respect to the breach of this agreement or any contract entered into between the parties pursuant hereto shall not exceed the price of the product or part on which such liability is based. In no event will Humanscale be liable to purchasers for any special, collateral, incidental or consequential damages however caused, whether by Humanscale's negligence or otherwise.

The remedies provided above are the purchaser's sole remedies for any failure of Humanscale to comply with its obligations regarding the workmanship of its products. Correction of any nonconformity in the manner and for the period of time provided shall constitute complete fulfillment of all liabilities of Humanscale, with respect to or arising out of the product furnished hereunder.



Seating Pricing and Specification Guide

Price Guide - U.S. Prices effective November 2008

U.S. Headquarters

11 East 26th Street
8th Floor
New York, NY 10010
212 725 4749
212 725 7545 fax

Customer Service

10 Inverness Drive East
Suite 100
Englewood, CO 80112
800 400 0625
303 858 9912
303 858 9916 fax
info@humanscale.com

European Headquarters

13 Northburgh Street
London
EC1V 0JP
United Kingdom
+44 207 566 7990
+44 207 566 7991 fax
info@humanscale.co.uk

www.humanscale.com



Our Design Philosophy

At Humanscale, we believe the best designs in the world are based on purpose and function. If a design solves a functional problem as simply and elegantly as possible, the resulting form will be honest and timeless.

Recognized by I.D. Magazine as one of the 10 "Best Companies" worldwide that help push design forward.