

## AL\_CONFERENCE

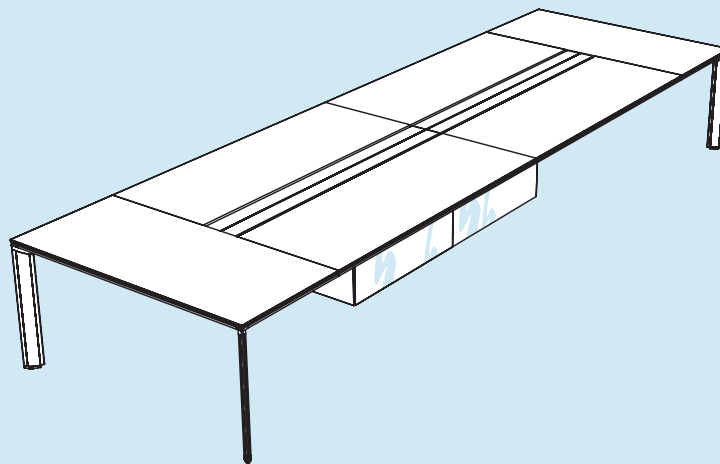

Produktübersicht.....	2
Grundgestell.....	3
Zargen und Mittelfüße.....	4
Kabelkanal.....	5
Verkabelung.....	6
Kabelkanalverblendung.....	7
Verspiegelte Blenden.....	8
Tischplatten positionieren.....	9
Tischplatten fixieren.....	10
Pflege- und Sicherheitshinweise.....	11
Notizen.....	12

<i>Products at a glance.....</i>	<i>2</i>
<i>Base frame.....</i>	<i>3</i>
<i>Crossbars and central legs.....</i>	<i>4</i>
<i>Wire trunking.....</i>	<i>5</i>
<i>Cabling.....</i>	<i>6</i>
<i>Modesty panel for wire trunking.....</i>	<i>7</i>
<i>Mirrored modesty panels.....</i>	<i>8</i>
<i>Table top positioning.....</i>	<i>9</i>
<i>Table top fixing.....</i>	<i>10</i>
<i>Care and safety instructions.....</i>	<i>11</i>
<i>Notes.....</i>	<i>12</i>

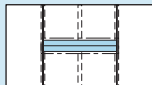

1560/2800



1560/3200

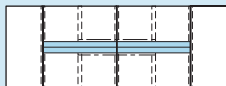

1560/4200



1560/5000

\* Anleitung anhand dieses Modells.

\* Operating instructions are based on this model.

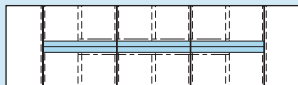

1560/5600

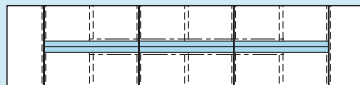

1560/6800



Zarge. Desk frame.



Blenden. modesty panels.

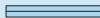

Kabelkanal. wire trunking.

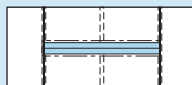

1560/3600

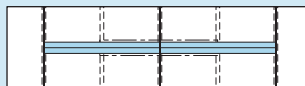

1560/5800



1560/8000

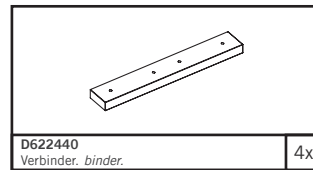
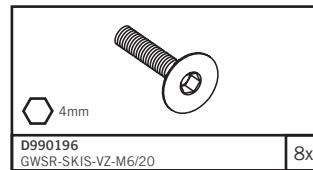
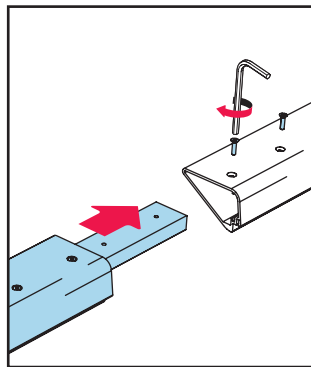
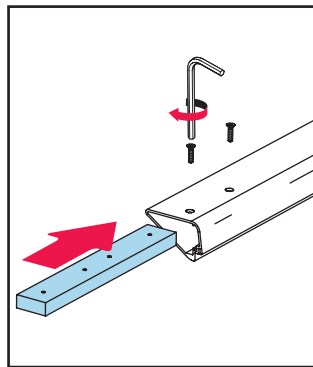
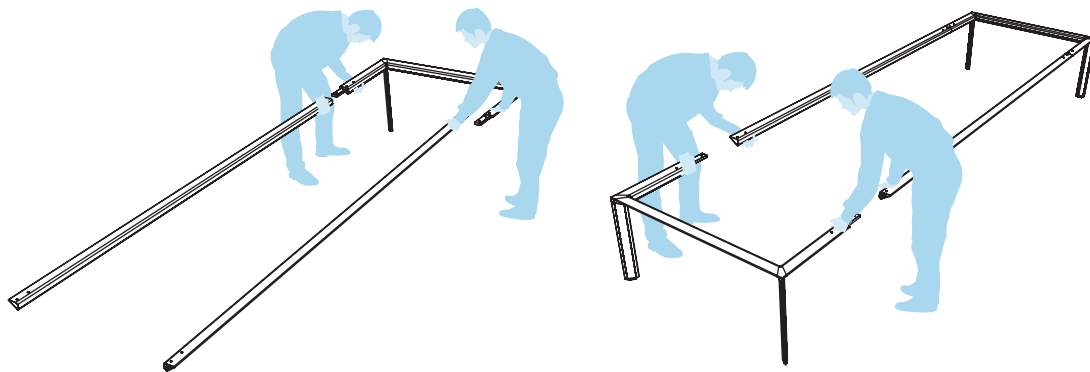
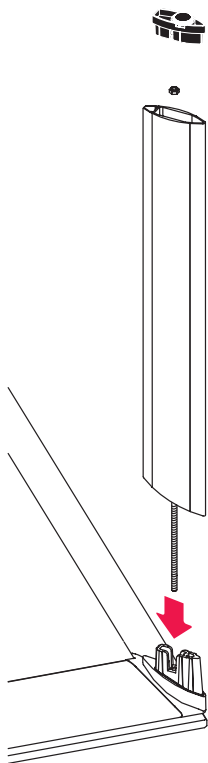

ZARGEN UND MITTELFÜSSE.  
CROSSBARS AND CENTRAL LEGS.

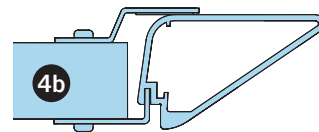
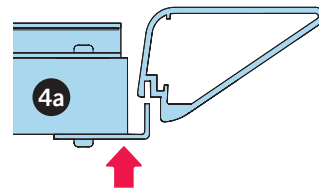
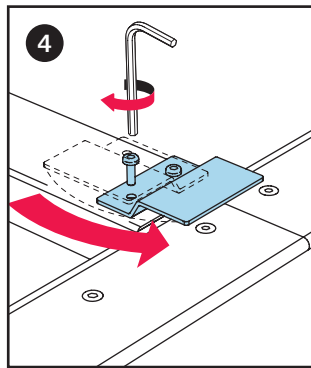
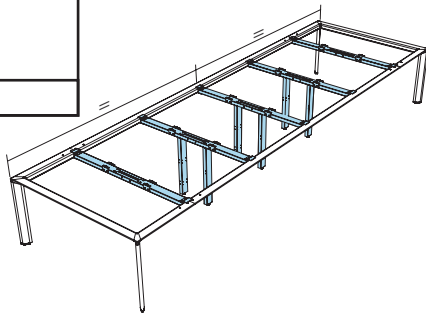
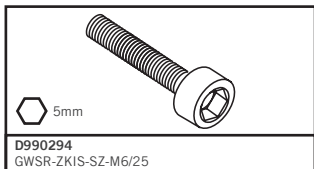
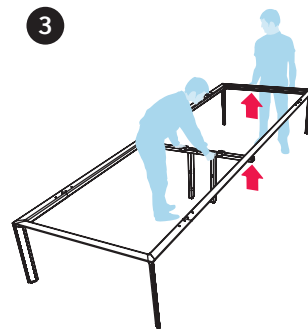
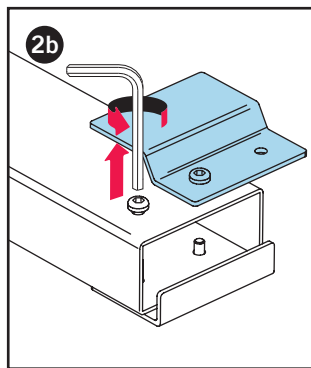
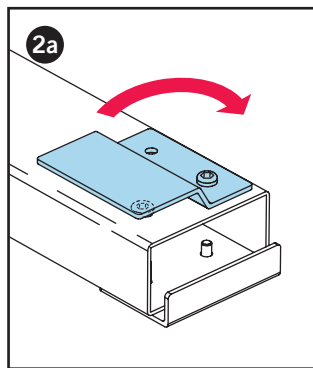
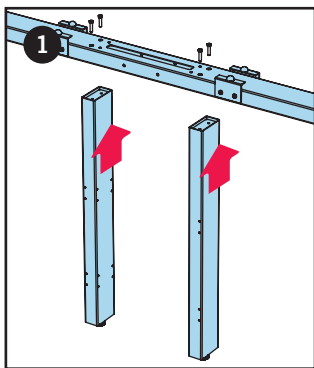

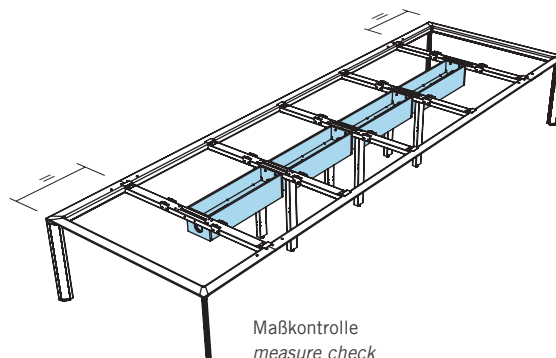
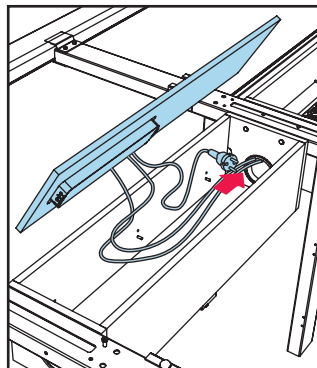
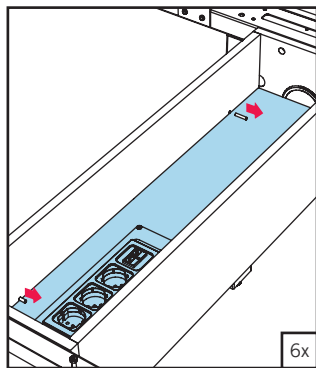
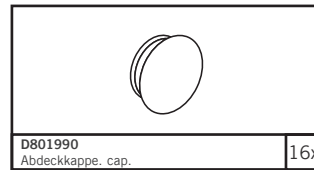
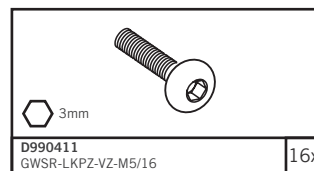
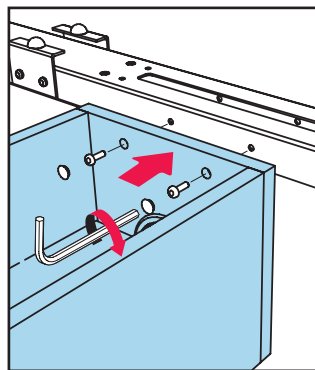
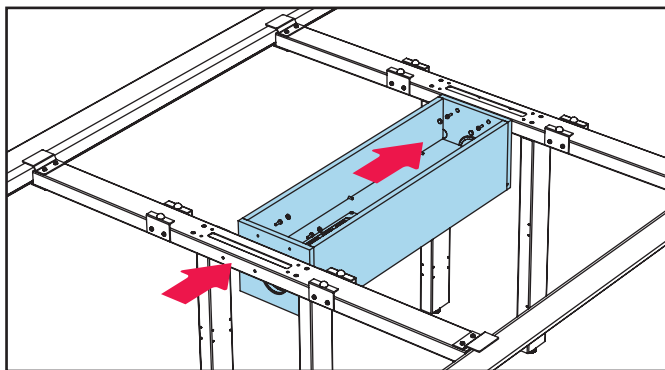

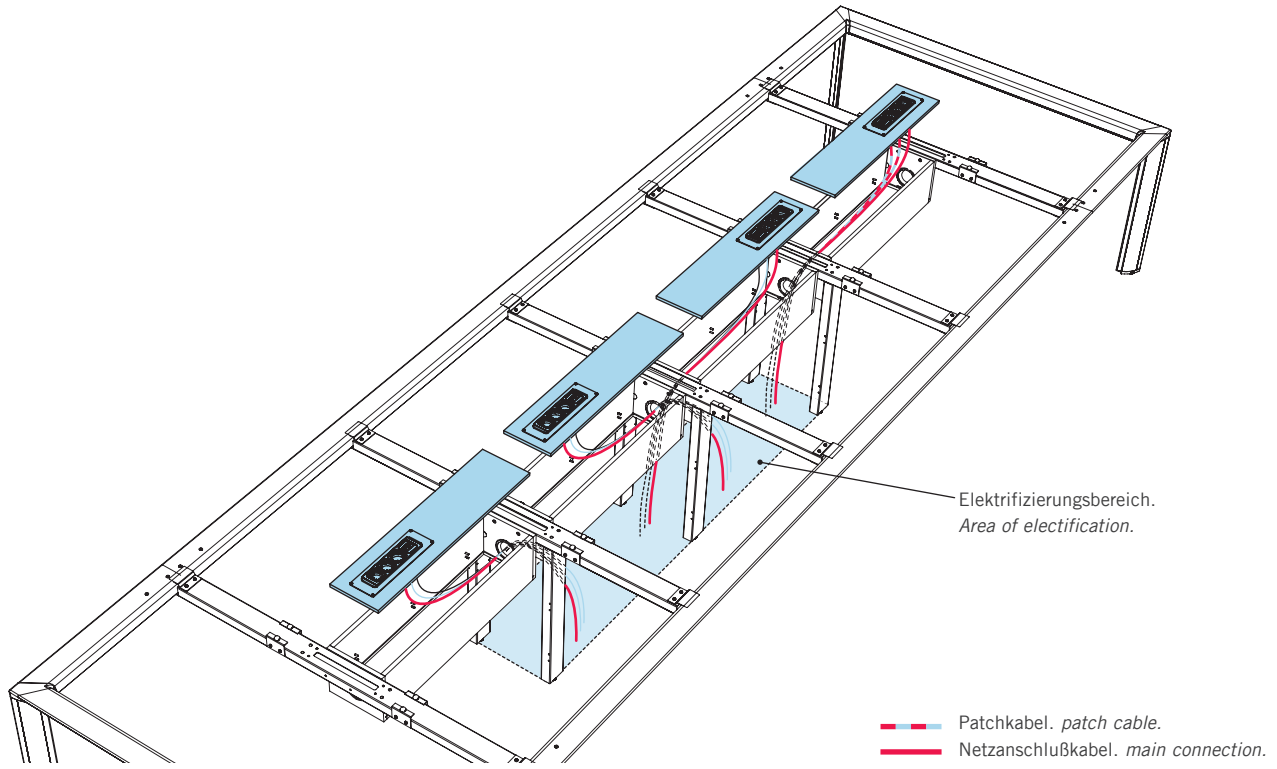

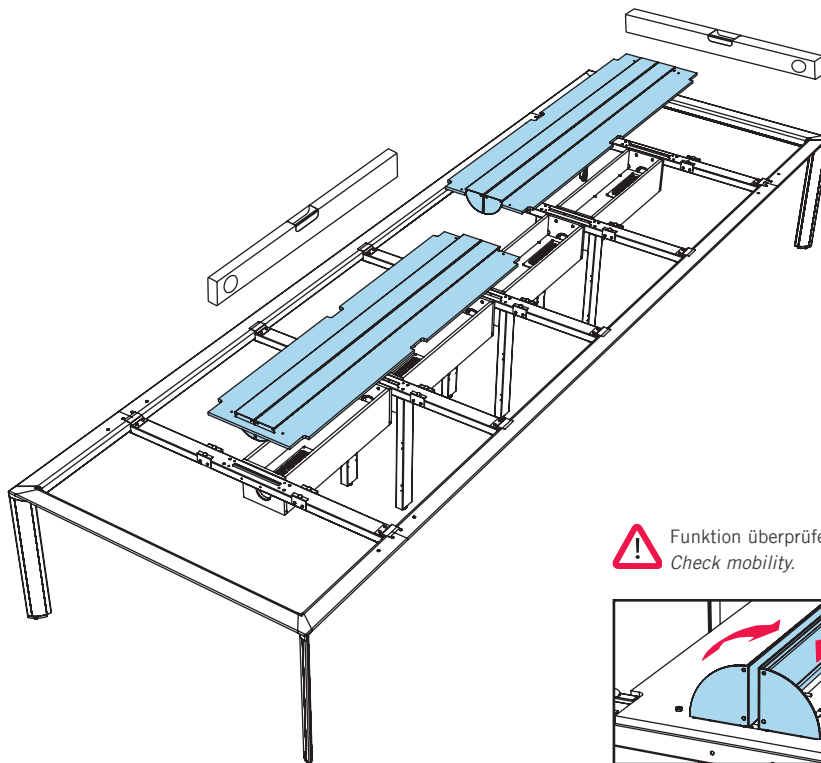
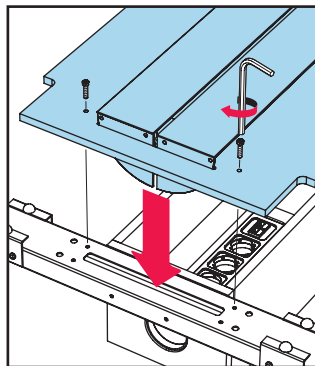
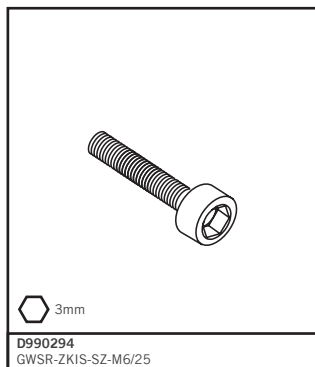

Elektrifizierungsbereich.  
Area of electrification.

- Patchkabel. *patch cable.*
- Netzanschlußkabel. *main connection.*



 Funktion überprüfen.  
Check mobility.

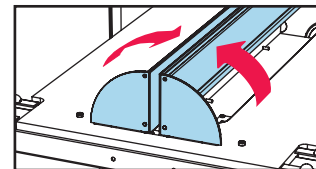

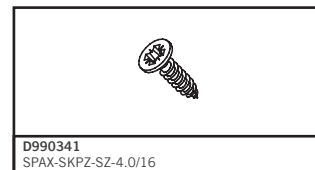
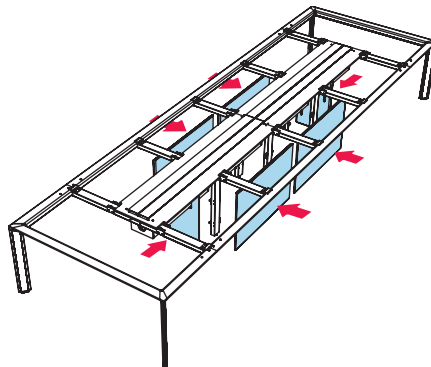
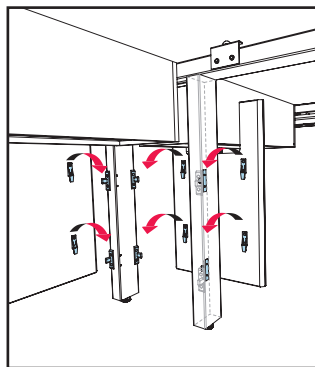
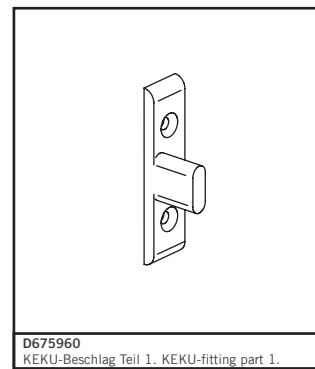
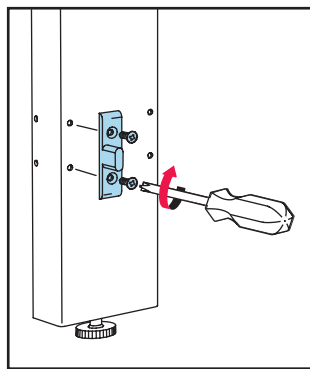
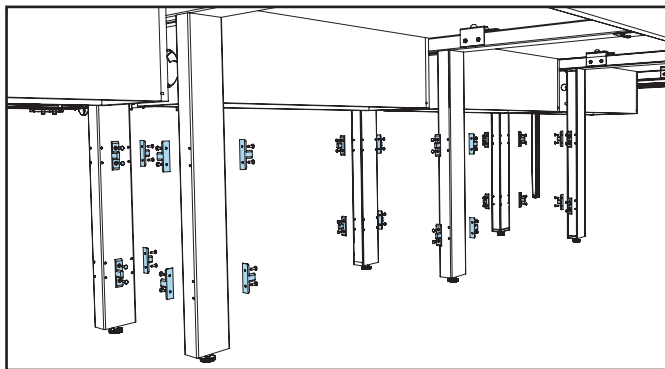

TISCHPLATTEN POSITIONIEREN.  
TABLE TOP POSITIONING.

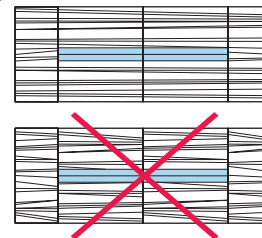
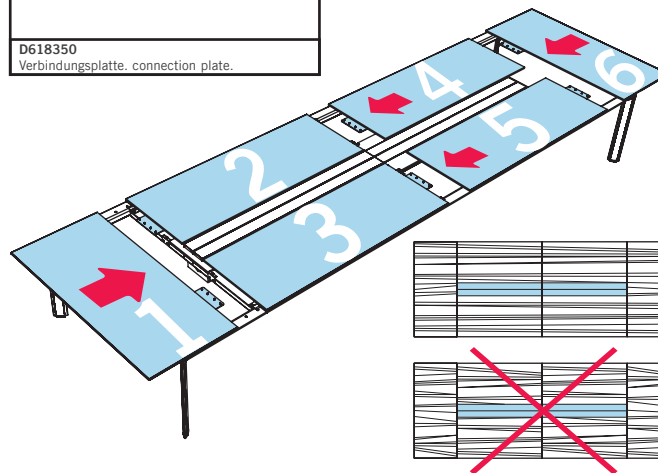
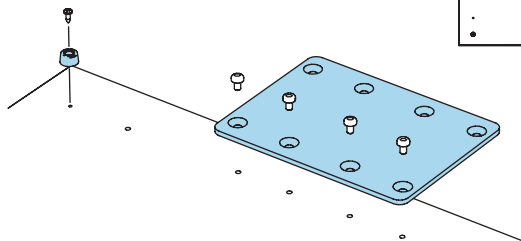
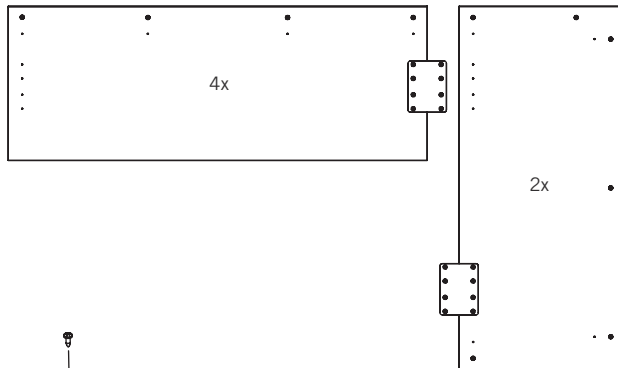
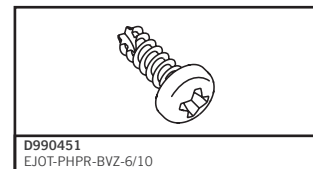
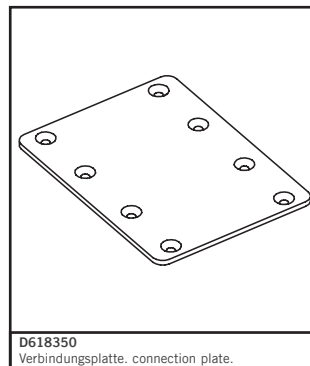
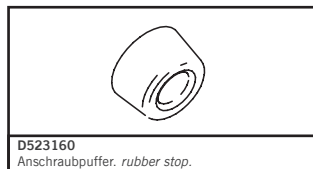
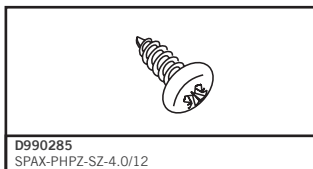

TISCHPLATTEN FIXIEREN.  
TABLE TOP FIXING.

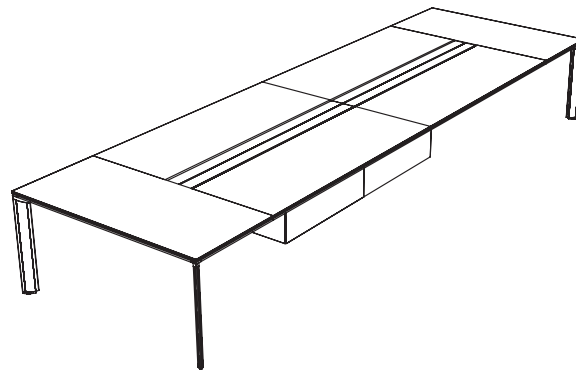
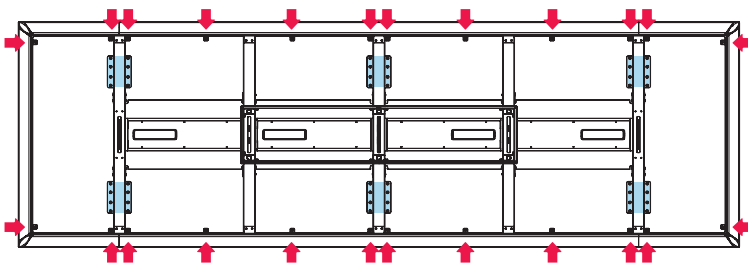
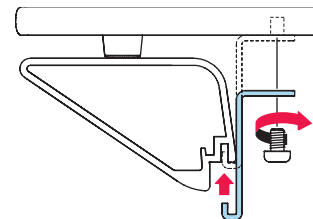
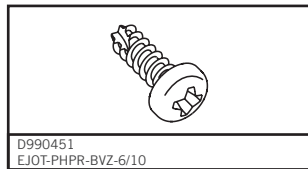
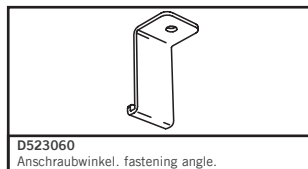
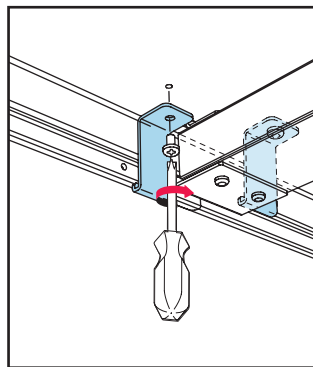
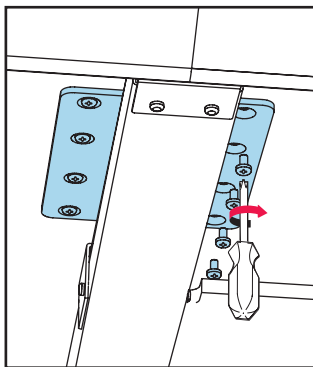

### Pflegehinweise

Die schonende und sachgemäße Reinigung der Oberflächen Ihrer Möbel und Wände ist wichtig, um deren optimalen Zustand möglichst lange zu erhalten. Wir empfehlen die Verwendung handelsüblicher Möbelreinigungsmittel für furnierte und kunststoffbeschichtete Oberflächen.

### Cleaning instructions

*Careful and appropriate cleaning of the furniture surfaces and components guarantees optimum durability.*

*We recommend standard furniture polish for veneer or melamine-coated surfaces.*



Steckdosenleisten müssen zuverlässig befestigt sein und so platziert werden, dass die Stecker leicht gesteckt und gezogen werden können. Stecker und Steckdosenleisten müssen so positioniert sein, daß bei vorschriftsmäßigen Gebrauch der Büromöbel keine Flüssigkeit in oder auf die elektrischen Betriebsmittel fließen kann.

*Multiple socket outlets must be fixed or placed safely for easy plugging and unplugging. Plugs and multiple socket outlets must be placed to avoid contact of electrical equipment with liquids (provided furniture is properly used).*



Das Netzanschlusskabel muss fest in der Zugentlastung des Fußgestells montiert werden. Verbindungskabel dürfen lose verlegt werden. Alle Leitungen und Kabel müssen so verlegt werden, dass keine Gefahr von Abscheren, Abrieb oder anderen mechanischen Beschädigungen besteht.

*The power cable must be fixed in the leg frame's strain relief. Connecting wires may be run loosely. All lines and wires must be run to avoid shear, abrasion or other mechanical damage.*



Bei Arbeitstischen, die mit beweglichen oder höhenverstellbaren Arbeitsflächen ausgerüstet sind, muss besondere Sorgfalt angewendet werden. Die Kabellängen müssen so ausreichend bemessen sein, dass die Bewegung der Arbeitsfläche ohne Dehnung oder Quetschung der Kabel möglich ist.

*Desks with flexible or height-adjustable worktops require special care. Cables must be sufficiently long to allow moving the worktop without stretching or compressing cables.*

Two columns of horizontal dotted lines for writing notes.

Two columns of horizontal dotted lines for writing notes.

Two columns of horizontal dotted lines for writing notes.

**BENE HEADOFFICE A-3340 WAIDHOFEN/BBS** SCHWARZWIENSENSTRASSE 3 TELEFON +43-7442-500-0 E-MAIL OFFICE@BENE.COM

**ÖSTERREICH:** BREGENZ, GRAZ, INNSBRUCK, KLAGENFURT, LINZ, SALZBURG, ST. PÖLTEN, WIEN. **BULGARIA:** SOFIA. **CZECH REPUBLIC:** PRAQUE. **DEUTSCHLAND:** ASCHAFFENBURG, BERLIN, BONN, DÜSSELDORF, ESSEN, FRANKFURT, HAMBURG, HANNOVER, LEIPZIG, MANNHEIM, MÜNCHEN, SCHWENNINGEN, STUTTGART-MÖHRINGEN. **HUNGARY:** BUDAPEST. **IRELAND:** DUBLIN. **MIDDLE EAST:** DUBAI. **POLAND:** WARSAW. **ROMANIA:** BUCHAREST. **RUSSIAN FEDERATION:** MOSCOW. **SERBIA:** BELGRAD. **SLOVAKIA:** BRATISLAVA. **SLOVENIA:** LJUBLJANA. **SWITZERLAND:** WÄLTISELLEN. **UKRAINE:** KIEV. **UNITED KINGDOM:** LONDON.

**FACHHANDELPARTNER / TRADING PARTNERS:** BELGIUM: ZAVENTEM. **CROATIA:** ZAGREB. **DENMARK:** COPENHAGEN. **DEUTSCHLAND:** BAYREUTH, BREMEN, DONAUWÖRTH, ERLANGEN, MÜNSTER, NÜRNBERG, REGENSBURG, SAARBRÜCKEN, SAARLOUIS, SÜSSEN. **FRANCE:** LILLE, LYON, MONTPELLIER, NANTES, NICE, PARIS, TOULOUSE. **ITALY:** MERANO. **KUWAIT:** KUWAIT. **LIECHTENSTEIN:** SCHAAN. **LUXEMBOURG:** LUXEMBOURG. **NETHERLANDS:** HAAKSBERGEN, ROTTERDAM, WILF. **QATAR:** DOHA. **SPAIN:** BARCELONA.

[HTTP://BENE.COM](http://bene.com)