

LEUCOS®

ISTRUZIONI DI MONTAGGIO E MANUTENZIONE INSTALLATION INSTRUCTIONS

CELINE P - CELINE P35

Celine P



Celine P 35

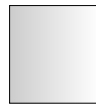

A1 Allegato Enclosed



Montaggio 1 persona
One installer



Conservare le istruzioni
Save instructions

Indice di edizione - Revised
21.01.2009

I **NOTA: - Eseguire le operazioni con molta attenzione per non graffiare o scheggiare il vetro.**
- Prima di eseguire ogni operazione assicurarsi di aver disinserito l'alimentazione.

- FIG.1** Fissare la struttura "A" alla parete.
- Rivestire i cavi di rete con le guaine di protezione fornite in dotazione.
- Eseguire i collegamenti alla rete di alimentazione.
- FIG.2 - 3 - 4** Inserire le lampadine.
- FIG.4** Posizionare il vetro sotto la piegatura della montatura "A" ed fissarlo ad essa con la basetta "B" tramite la vite "J".
- Se necessario regolare l'assetto orizzontale del vetro agendo sui grani "W".
- Se il vetro in fase di serraggio della vite "J", tende a distaccarsi dalla parete, svitare la vite "J" e regolare il grano "X" in modo da impedire lo scivolamento del vetro.
- Riattivare l'alimentazione di rete.

CELINE P 1x100W K E27 1x100W AL E27 250V- 2x26W F G24 q3 220/240V
CELINE P 35 1x100W K E27 1x150W AL E27 250V- 2x26W F G24 q3 220/240V
CELINE P 35 2x26W - F G24 q3 220/240V+ emergenza

ATTENTION:

F **- Avant d'effectuer quelque opération que le secteur primaire soit hors tension.**
- Effectuer les opérations avec précaution pour ne pas rayer ou casser le verre.

- FIG.1** Fixer la patère "A" au mur.
- Recouvrir les câbles d'alimentation avec les gâines de protection fournies en dotation.
- Effectuer les connexions à l'alimentation générale.
- FIG. 2-3-4** Mettre la source.
- FIG.4** Placer le diffuseur sous la languette inférieure de la patère "A", le fixer sur celle-ci avec la vis "J" en couvrant soigneusement le trou de la base "B".
- Régler la position du verre, si nécessaire, en ageant sur les vis "W".
- Si pendant le serrage de la vis "J" le verre se détache du mur, dévisser la vis "J" et régler le pivot "X" pour éviter le glissement du verre.
- Activer l'alimentation sur secteur.

LEUCOS S.p.A. - Via Moglianese 29/31- 30037 SCORZE' (VE) - Tel. 041 5859111 - Fax. 041 447598
www.leucos.it - e-mail info@leucos.it

Fig.1

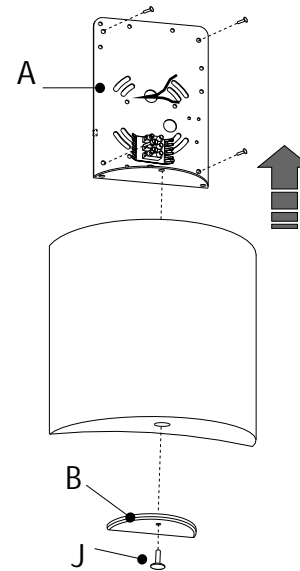

Fig. 2

INCANDESCENTE
ALOGENA

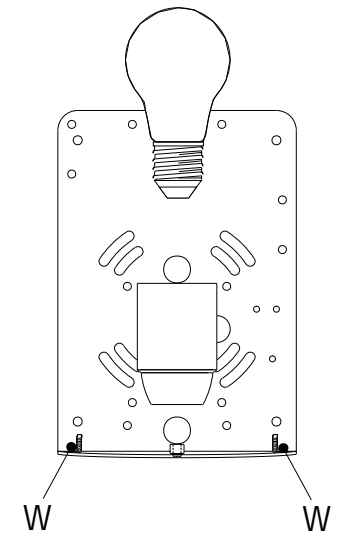

Fig.3

FLUORESCENTE

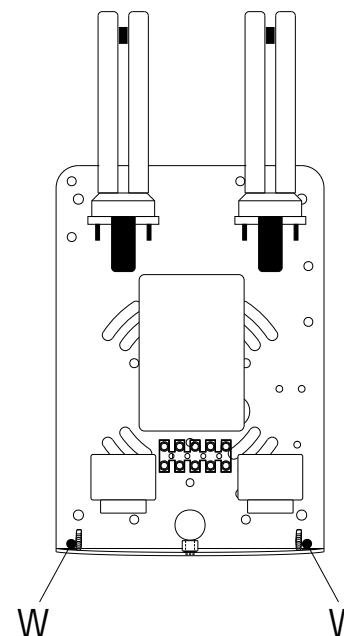
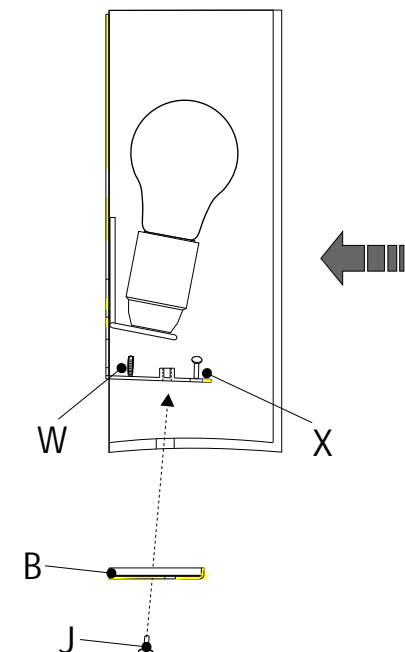

Fig.4



UK



WARNING: - Disconnect power before installation. - Fixture to be installed by a certified electrician. - Install in accordance with the national and local electrical codes. - Take great care to avoid scratching or chipping the glass when carrying out the operations below

USA



- FIG.1** Attach palye "A" to the wall (J-box for U.S.A.market only).
- Cover the wire cables with the protections sheathes in equipment.
- Make electrical connections to supply wires.
- FIG. 2 - 3 - 4** Install the light bulb(s).
- Carefully position the glass shade underneath the botton plate "A". See **FIG.4** and secureit with screw "J"and metal cover"B".Make sure the semi-circular opening is covered with "B".
- If necessary, tighten screws "W" to adjust the corrent position of the diffuser.
- If the glass during the fixing of the screw "J" seems to come off the wall, loosen the screw "J" and adjust the pin "X" to avoid that glass may slide.
- Restore power.

FOR U.S.A. MARKET ONLY:

CELINE P :

-  max 1x100W 120V - E26 TYPE A
-  2x13W 120V - GX23 TYPE QUAD TUBE

CELINE P35:

-  max 1x100W 120V - E26 TYPE A
-  2x18W 120V - G24 q2 TYPE QUAD TUBE
-  2X13W - 120V 2GX7 TWIN TUBE

For additional information please contact your local dealer or **LEUCOS U.S.A.**

At: Tel. (732) 225-0010 Fax (732) 225-0250

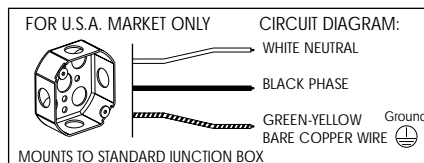
**P**

NOTA: - Antes de executar qualquer operação verificar terdesligado a corrente eléctrica.
 - Executar as operações com muita atenção para riscar ou lascas o vidro.

- FIG.1** Fixar a estrutura "A" à parede.
- Revestir os cabos de alimentação com as bainhas de protecção já fornecidas.
- Executar as ligações à corrente eléctrica.
- FIG. 2 -3- 4** Introduzir as lâmpadas.
- FIG.4** Posicionar o vidro debaixo da dobra da armação "A", conforme e fixá-lo a ela com o parafuso "J", cobrindo cuidadosamente o furo semicircular com a base "B".
- Em caso de necessidade, regular a posição horizontal do vidro actuando nos pernos "W".
- Se o vidro, durante o aperto do parafuso "J", tende a soltar-se da parede, desaparafusar o parafuso"J" e regular o perno "X" de maneira a impedir o deslizamento do vidro.
- Activar a corrente eléctrica.

D

HINWEIS:

- VOR BEGINN DER ARBEIT IMMER DIE STROMVERSORGUNG UNTERBRECHEN.
 - MIT GRÖSSTER SORGFALT VORGEHEN, UM DAS ZERKRATZEN DES GLASES ZU VERMEIDEN.

- FIG.1** Montage an die Ward montieren.
- Überziehen Sie die Netzkabeln mit Schutzhülsen, die serienmassig geliefert werden.
- Leuchte an das Netz anschließen.
- FIG. 2-3-4** Glühmittel einschrauben.
- FIG.4** Glaselement unter der Falte der Montage "A" aufsetzen wie und mit Schreube "J" und Lasche "B" an die Montage fixieren.
- Falls notwendig , stellen Sie die horizontale Trimmung des Glases mit den Plastik schrauben "W" ein.
- Wenn es während der montage des Glases den anschein hat, dass sich das Glas von der Struktur löst, die Schraube "J" aufschrauben und den Stift "X" so regulieren, um das abrutschen des Glases zu verhindern.
- Stromzufuhr aktivieren.

E

NOTA: - ANTES DA CONTINUAR, ASEGURARSE DE TENER DESCONECATADA LA CORRIENTE ELÉCTRICA.
 - SEGUIR LAS INTROCCIONES CON MICHA ATENCIÓN PARA NO RALLAR NI ASTILLAR EL CRISTAL.

- FIG.1** Fijar la estructura "A" a la pared.
- Revestir el cable de alimentación con las fundas de proteccion servidas con la lámpara.
- Realizar las coxiones a la red de alimentación.
- FIG.2 - 3 - 4** Introducir las lámparas.
- FIG.4** Posicionar el cristal bajo el pliegue del montante "A", ver dibujo,y fijarlo a ella con el tornillo "J" cubriendo cuidadosamente el agujero semicircular con la patille "B".
- Regular la posición del cristal, si es necesario, actuando sobre al tornillo "W".
- Si durante el montaje de el tornillo "J" el cristal tende a alejarse de la pared, destornillar el tornillo "J" y regular el perno "X".
- Conectar la alimentación a red.