

NUBIA S2-45 / S2-60 pendant

Design R. Toso -N.Massari & Associates

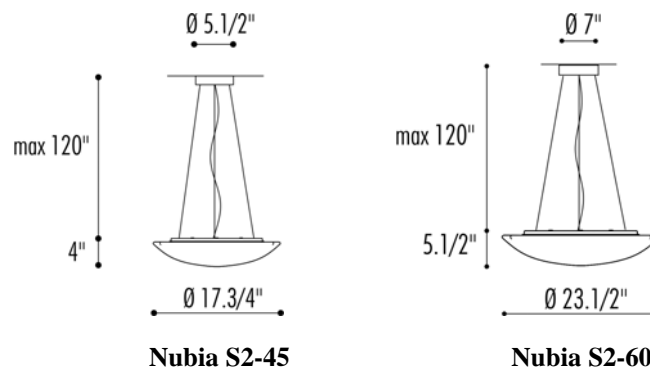

- DESCRIPTION:** A cloud-like pendant highlighted by a scalloped, hand blown glass diffuser available in 2 sizes and 4 glass finishes. Companion wall, ceiling and other pendant styles available.
- CONSTRUCTION:** A round canopy in brushed nickel attaches to a standard 4'' octagonal junction box. 10' of adjustable cord and cable support the blown glass diffuser.
- LIGHT SOURCE:** 1 x 200 watt, quartz halogen, T3 RSC (Provided)
- FINISH:** Brushed Nickel
- GLASS COLOR:** Satin White
Satin Amber
White Zebra Stripe
Amber Zebra Stripe
- NET WEIGHT:** S2-45: 17 lbs.
S2-60: 21 lbs.

Leucos USA, Inc.
11 Mayfield Avenue
Edison, NJ 08837
Tel: 732-225-0010
Fax: 732-225-0250
www.leucos.com