

**ECO
RIGHT**

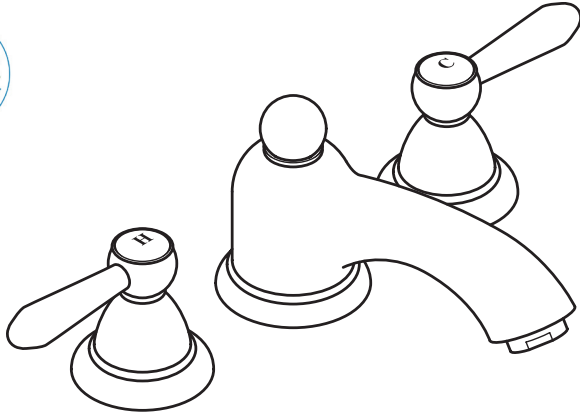

Product Features

- Lever handles
- Flexible connection hoses
- 90° Ceramic cartridges
- Includes pop-up drain
- 1.5 gpm

Code Compliance

This unit meets or exceeds the following:

- ASME A112.18.1
- CSA B125.1
- ADA compliant
- Listed by IAPMO
- WaterSense certified
- Approved for use in Massachusetts

Available Finishes

Chrome	17135001
Oil Rubbed Bronze	17135621
Brushed Nickel	17135821
Polished Nickel	17135831

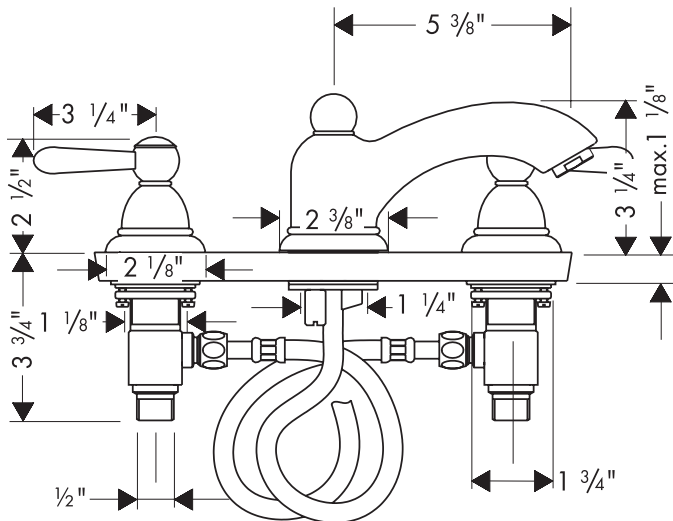

Installation Notes

- Requires 1/2" supply lines

The measurements shown are for reference only.

Products and specifications shown are subject to change without notice.

Specification sheet revised 5/2009