

Product Features

- On/off valve
- Ceramic cartridge
- 7" showerhead
- Handshower with 3 spray modes: full, water saving, soft aerated, Quiclean™ cleaning system, 2.5 gpm
- 1/2" NPT male inlets

Code Compliance

This unit meets or exceeds the following:

- ASME A112.18.1
- CSA B125.1
- Listed by IAPMO
- Approved for use in Massachusetts

Available Finishes

Chrome	39620001
Brushed Nickel	39620821

Optional Accessories

In-line pressure balance valve	13418181
--------------------------------	----------

Installation Notes

- Not anti-scald. Install with in-line pressure balance valve if required by local code.

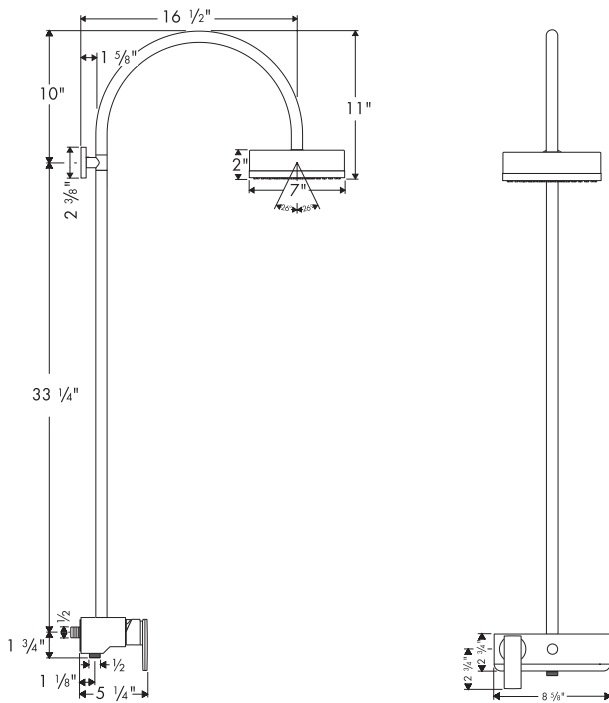

The measurements shown are for reference only.

Products and specifications shown are subject to change without notice.

Specification sheet revised 2/2008