

Flute - Magnum

FontanaArte spa reserves the right to make changes on this document and on the products here described without any prior notice.

Copyright © 2008 FontanaArte spa. All rights reserved.

It is forbidden to modify the present document, even partially, without a prior written authorisation by FontanaArte spa.

COMPANY:

PROJECT:

DATE:

PRODUCT NAME: Flute - Magnum

CODE NUMBER: 3300/1

COLLECTION: FontanaArte

TYPE: Floor

DESIGNER: Franco Raggi

PRODUCTION YEAR: 1999

Floor lamp. Borosilicate transparent glass stem.
Reflector in chromeplated polished aluminium. Base and reflector support in chromeplated metal.
Transparent feeding cable. The cone houses a reflector hold by three chrome-plated arms. The light reflects into the cone, thus giving a uniform light emission upwards. Dimmable.

FontanaArte

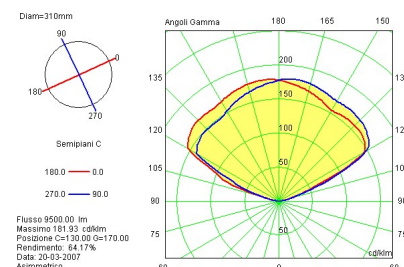
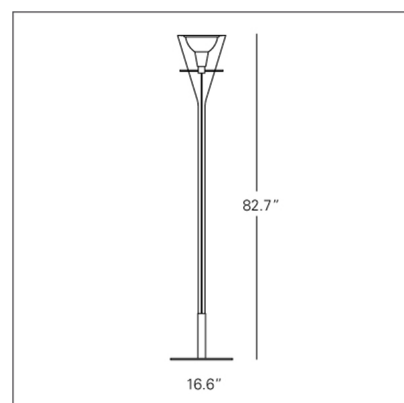

Light source: 1x300W T3/L Double Ended R7s - long (HA)