

lzf



POWERED BY
GlobalLighting

www.globallighting.com



Air
Ray Power

AIR Ray Power

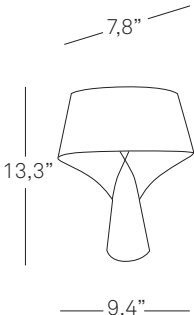
TABLE	INFO	Lamping	Ship Wgt + Dims	Model Specify colour	Size
	<p>Natural wood</p> <p>AIR MP CHW Cord lenght: 6" clear</p> <p>AIR MG CHW Base: brushed nickel</p> <p>Cord lenght: 6" clear</p> <p>Family table and wall</p>	 1 x 13 W CFL spiral GU24 base	4 lb 11x17x12"	AIR MP CHW	





1 x 13 W
CFL spiral

 GU24 base

5 lb
 16x16x24"

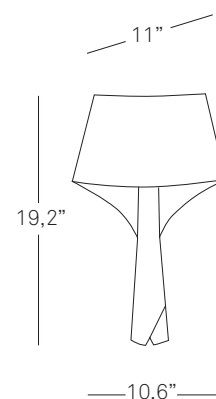
AIR MG CHW

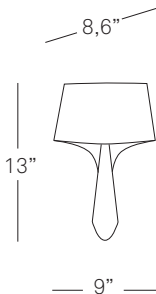

WALL	INFO	Lamping	Ship Wgt + Dims	Model Specify colour	Size
	<p>Natural wood</p> <p>Hidden back plate: chrome</p> <p>Satinice perspex diffuser</p> <p>Family table and wall</p>	 1 x 13 W CFL spiral GU24 base	3 lb 11x17x12"	AIR A CHW	



AIR Ray Power

FAMILY

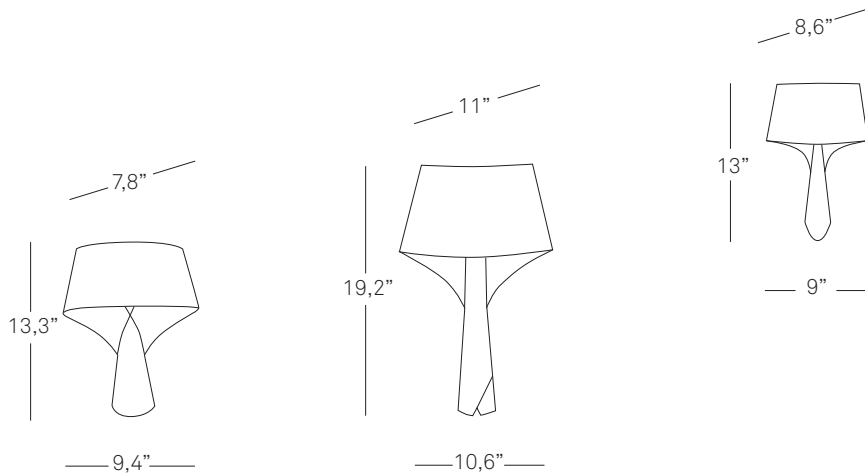

Chicago 2009



reddot design award
2010

SHADE FINISHES

REF. CHW

Natural timber veneer



CHW-20
American white wood

CHW-25
Orange

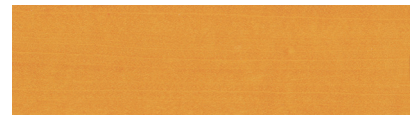

CHW-21
Cherry

CHW-26
Red

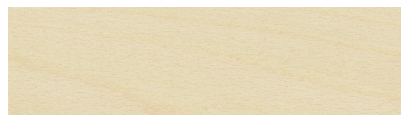

CHW-22
Beech

CHW-27
Green



CHW-24
Yellow

CHW-29
Grey





Ray Power

This design is born from Ray Power's continued investigation of the possibilities of Polywood® along with his specialty based on the study of making three dimensional shapes with planes.

The result is a shade and a base all in one that transmits visual stability and esthetic. Lzf presents this lamp which reflects itself in and is identified with, classic lamp formats.



