



North America

Power Base
Specification Guide—December 2009

Power Base™ Specification Guide

Table of Contents

PREMISE® Application

Power and Communication: Introduction	6
Power Statement of Line	7
Base Feed Modules	8
Top Feed Modules	10
Infeed Harness	14
Powered Panels	15
Power Kits	16
Power Connectors	18
Receptacles	22
Flip Top Unit: Details	24
Power Basics	25
Power Planning General Guidelines and Checklist	27
Power Distribution for Hardwire Applications	28
International Power Management	29
Cable Management: Introduction	30
Base Raceway: Communication Options and Dimensions	31
Data Access: Data Brackets	32
Cable Management	33

Compose® Application

Power and Communication: Introduction	38
Power Statement of Line	39
Base Feed Modules	40
Top Feed Modules	43
Powered Frame	45
Power Kits	46
Tile Options	47
Power Connectors	48
Receptacles	51
Flip Top Unit: Details	53
Power Basics	54
Power Planning General Guidelines and Checklist	56
Power Distribution for Hardwire Applications	57
International Power Management	58
Cable Management: Introduction	59
Base Raceway: Communication Options and Dimensions	61
Cable Management	62

Table of Contents

UniGroup Too®, UniGroup®, and PLACES® Application

Power and Communication: Introduction	64
Power Statement of Line	65
Base Feed Modules	66
Top Feed Modules	68
Powered Panels	70
Power Connectors	71
Port Kit Compatability	73
Receptacles	74
Flip Top Unit: Details	76
Power Basics	77
Power Planning General Guidelines and Checklist	79
Power Distribution for Hardwire Applications	80
International Power Management	81
Cable Management Introduction: UniGroup Too and UniGroup	82
Cable Management Introduction: PLACES	83
Cable Management Introduction: UniGroup Too, UniGroup, and PLACES	84
Cable Management: UniGroup Too and UniGroup	85
Cable Management: PLACES	86
Cable Management: UniGroup Too and UniGroup	88
Cable Management: PLACES	89
Cable Management: UniGroup Too, UniGroup, and PLACES	90
Cable Management: UniGroup	93

Tactics® Application

Power Management	96
Base Feed Modules	98
Power Distribution Assembly (PDA)	101
Power Connectors	102
Receptacles	104
Flip Top Unit: Details	106
Power Basics	107
Power Planning General Guidelines and Checklist	109

Price List	111
------------------	-----

Power and Communication: Introduction

The PREMISE system accommodates all power and cable management needs through the Power Base electrical distribution system and multiple cable pathways. Power Base is a modular electrical system available in the base raceway and at work-height (below worksurface, beltline, and standing height). Power Base is offered in 3-Circuit and 4-Circuit (2+2 or 3+1) configurations. Power Base components are designed to address three functions:

1. **In:** Routing power from the building into the furniture.
2. **Through:** Routing power through the furniture.
3. **Out:** Receptacle access at panel.

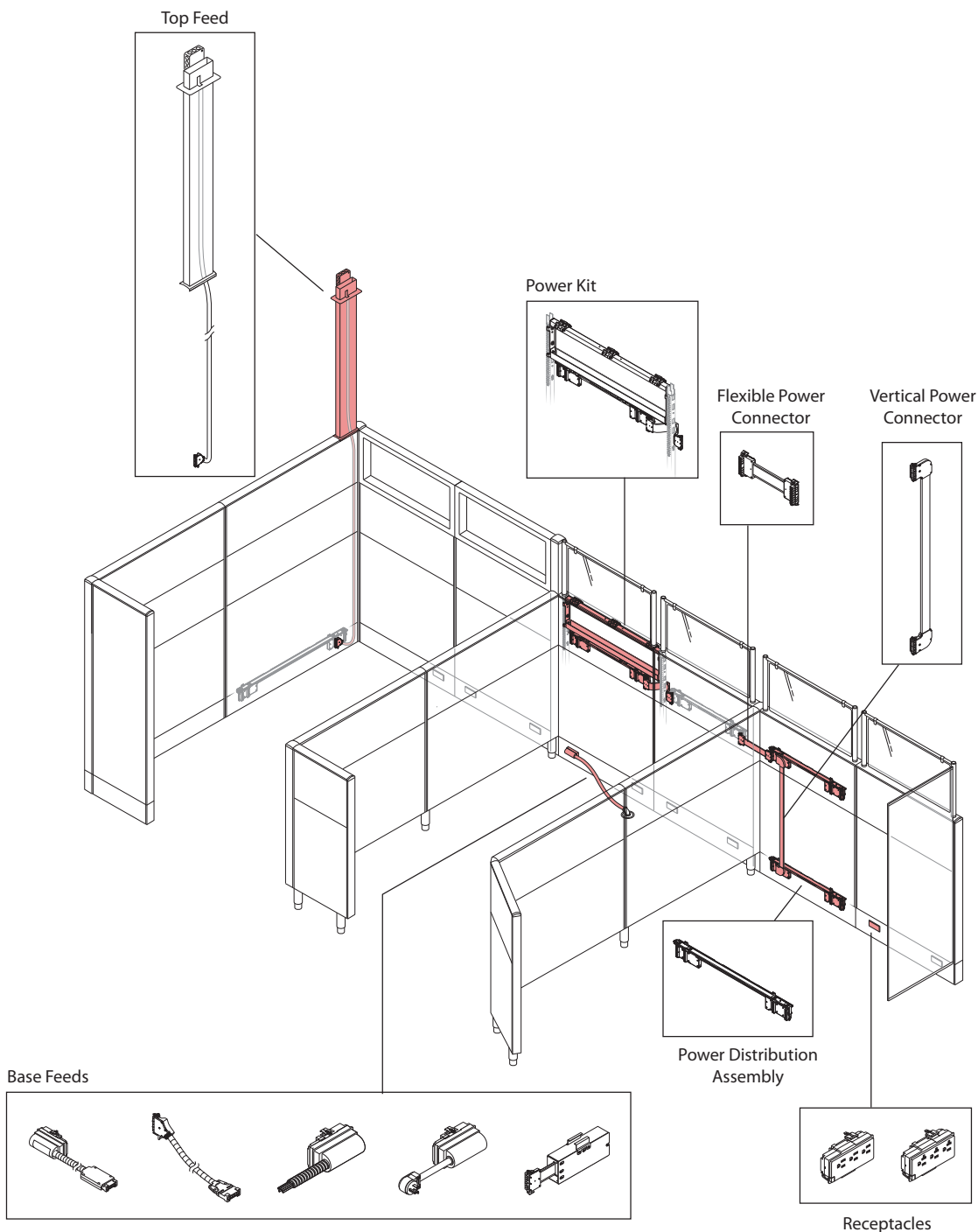

Power Statement of Line

In: Building to Panel

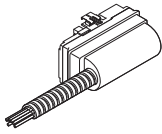

Base Feed Module:
Hardwire Connection

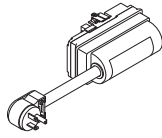

Single Circuit Base Feed Module:
Receptacle Connection with Power Cord

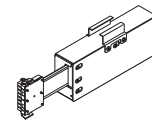

Base Feed Module: Concealed
Hardwire Connection

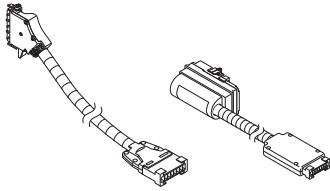

Power Base AI Feeds

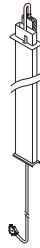

Top Feed Module

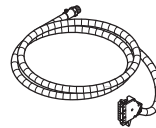

Infeed Harness



External Top
Feed Module

Through: Power Distribution

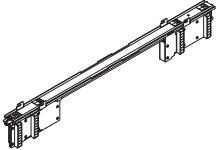

Power Distribution Assembly

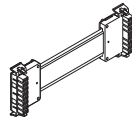

Flexible Power Connector



Vertical Power Connector

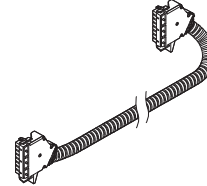

Extended Connector

Out: Receptacle Access

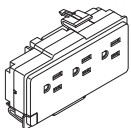

15 Amp Receptacle

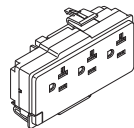

20 Amp Receptacle

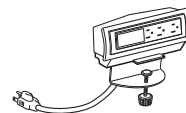

Desktop Port

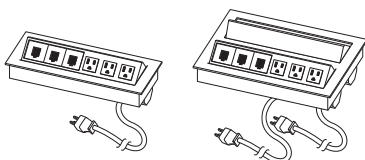

Flip Top Unit

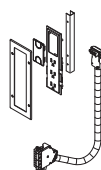

Port Kit

Base Feed Modules

Base Feed Module: Hardwire Connection

The module is used to transition from building wiring to modular power within the furniture. One end is hardwired to building wiring and the modular end snaps into the power distribution assembly (PDA) in the base of the furniture.

Specification Tips

- For use with 24" – 60" (610mm – 1524mm) wide powered panels.
- Not for use with open base raceway panels.

Power Locations

- Floor
- Column
- Wall

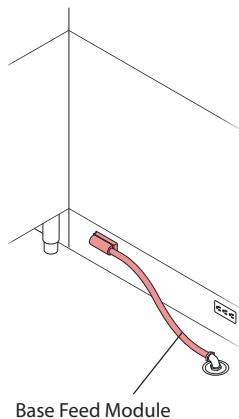
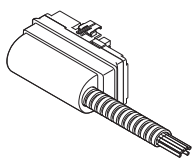

Single Circuit Base Feed Module: Receptacle Connection with Power Cord

The module is used to transition from building wiring to modular power within the base of the furniture. The cord end is plugged into a receptacle (NEMA 5-20R USA/NEMA 5-15R Canada) in the building and the modular end snaps into the power distribution assembly (PDA) in the furniture. Only circuit one is powered by a cord feed. This feed is used for small furniture clusters such as a reception desk. National codes restrict the length of the cord; 24" (610mm) in the United States, 72" (1829mm) in Canada.

Specification Tips

- For use with 24" – 60" (610mm – 1524mm) wide powered panels.
- Not for use with isolated ground receptacles.
- Not for use with open base raceway panels.

Power Locations

- Floor
- Column
- Wall

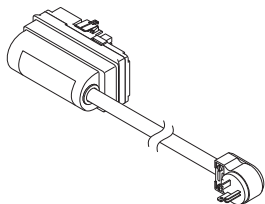

Column Cord Base Feed

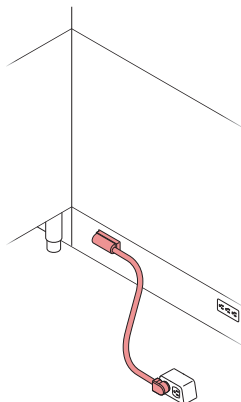

Base Feed Modules

Base Feed Module: Concealed Hardwire Connection

The module is used to transition building wiring to modular power within the furniture. The module's junction box is mounted to the furniture and its modular connector snaps into the power distribution assembly (PDA). Field supplied conduit is used to bring power from the building to the junction box allowing for some versatile applications. Although used primarily to meet New York City code requirements for a base fed infeed, it is not limited for use in this locale.

Specification Tips

- For use with 36" – 60" (914mm – 1524mm) wide powered panels.
- Not for use with open base raceway panels.

Power Locations

- Floor
- Column
- Wall

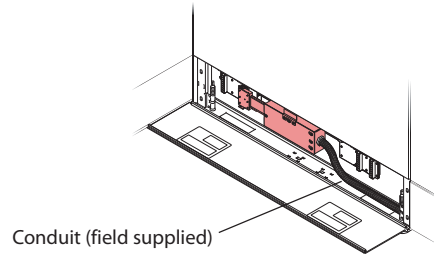
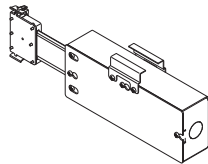

Note New York City code compliant.

Raised Floor Infeed Base Feed Module: External and Internal

These modules are used to make plug-and-play connections between Power Base AI underfloor modular power and Power Base modular power in furniture. Internal version can enter under the panel base so base feed is not visible. The conduit of the external version will be exposed, but allows flexibility in positioning the furniture.

Specification Tips

- For use with 24" – 60" (610mm – 1524mm) wide powered panels.
- Not for use with open base raceway panels.
- Can only be connected to Power Base AI underfloor power system.
- Black split tubing may be field supplied to cover any exposed galvanized metal conduit.

Power Location

- Power Base AI

External Base Feed

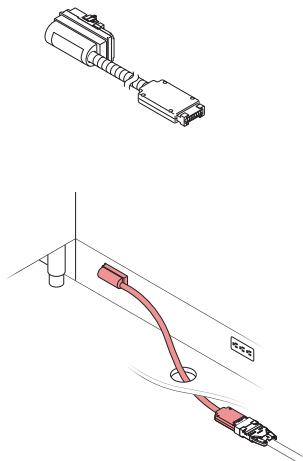

Internal Base Feed

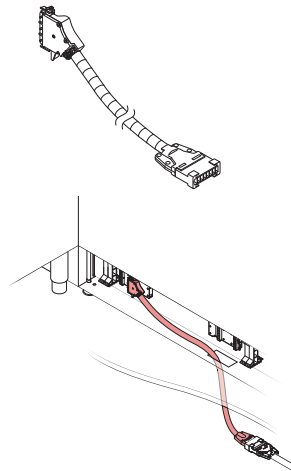

Top Feed Modules

Top Feeds are used to transition building wiring located in the ceiling to modular power within the furniture. One end is hardwired to a junction box and the modular end snaps into the power distribution assembly (PDA) in the panel.

Top Feeds with poles are used to span between ceiling and panels and are available with or without power harness for 10' or 12' ceiling heights. Floor-to-ceiling applications up to 10' route power through the panel and do not require a pole.

Application

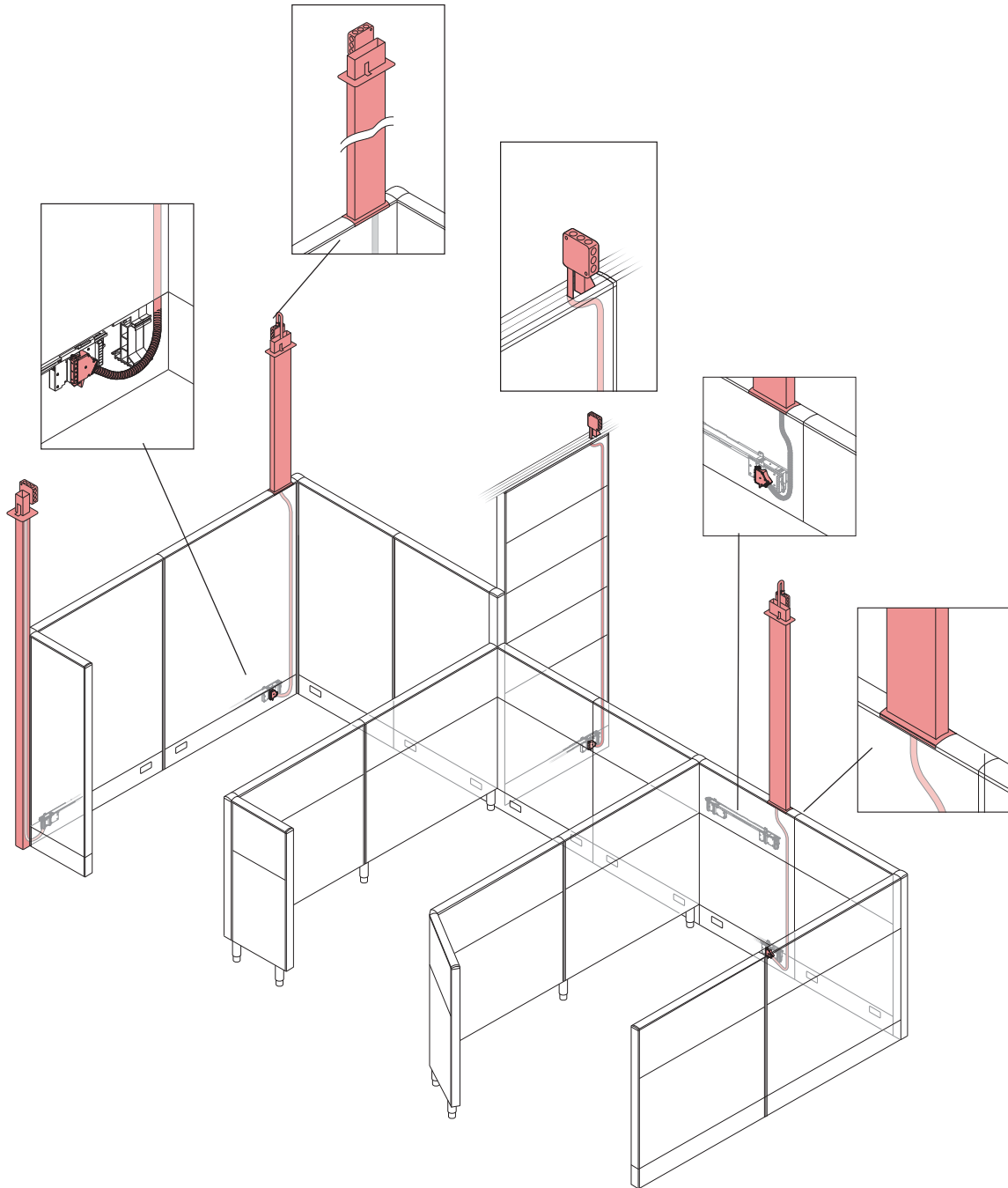

Note Refer to cable management section for more information about communication cable specification and planning.

Top Feed Modules

Monolithic Panel Top Feed

The module mounts to a fabric monolithic panel and routes power and communication cabling from the ceiling to the base raceway.

Specification Tips

- For use with 24" – 60" (610mm – 1524mm) wide powered panels.
- For use with 32" – 80" (813mm – 2032mm) high panels.
- Not for use with stackable panels.
- Not for use with glass or open base panels.
- Mounts 1½" (38mm) from the end of panel, field cutting of Top Cap is required.
- Wire harness length is 180" (4572mm) regardless of pole length.

Power Location

- 10' and 12' Ceilings

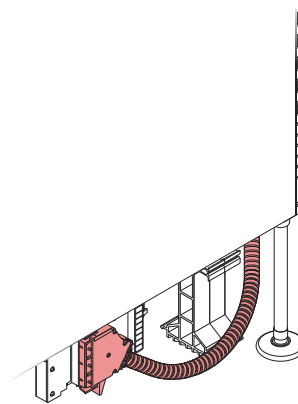
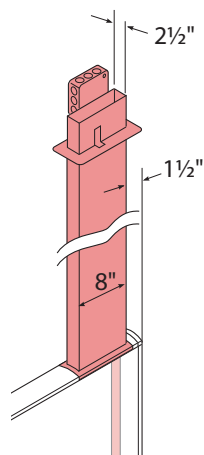

Monolithic Panel Base Connection

Stackable Panel Top Feed Module

The module mounts to a stack kit and routes power and communications cabling from the ceiling to the base raceway on Monolithic or Super Base panels. It can also route power to work heights in stack applications.

Specification Tips

- For use with 24" – 60" (610mm – 1524mm) wide powered panels.
- For use with 42" – 80" (1067mm – 2032mm) high panels.
- Not for use with glass, translucent, perforated or open stack kits.
- Not recommended for use on stack kits with structural crossbars.
- Mounts 5⅜" (136mm) from the panel end, field cutting of the Top Cap is required.
- Wire harness length is 180" (4572mm) regardless of pole length.

Power Location

- 10' and 12' Ceilings

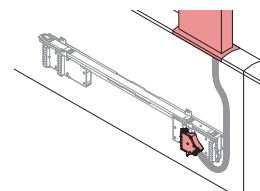
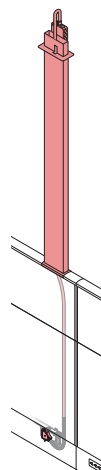
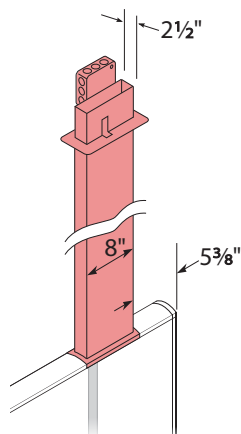

Work Height

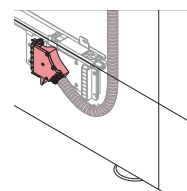

Base Height

Top Feed Modules

External Top Feed Module

The module routes power and communications cabling from the ceiling to the base raceway with any panel configuration including Monolithic or Super Base powered panels with open or glazed stack kits.

Specification Tips

- For use with 24" – 60" (610mm – 1524mm) wide powered panels.
- For use with 32" – 80" (813mm – 2032mm) high panels.
- Can be used in end-of-run, 2-Way, and 3-Way conditions on any panel type.
- Wire harness length is 180" (4572mm).
- Pole is 3" x 3" (76mm x 76mm) square.

Power Location

- 10' Ceilings

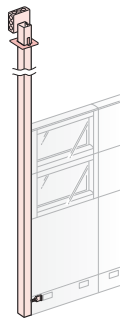

Attaches to Straight Connector

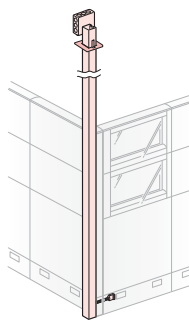

Separately Specify 3-Way Connector

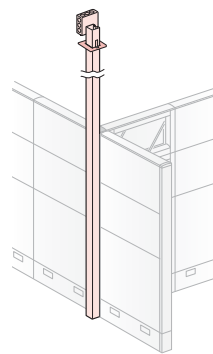

Separately Specify 4-Way Connector

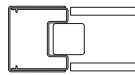

End-of-Run

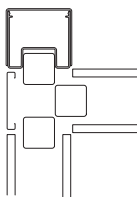

2-Way

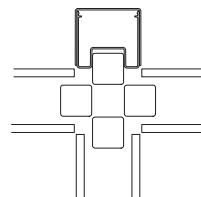

3-Way

Top Feed Modules

Floor-to-Ceiling Monolithic and Super Base Panel Top Feed Module

The module mounts to floor-to-ceiling track and routes power from the ceiling to the base raceway on Monolithic or Super Base panels. The module can also route power to work heights in stack applications.

Specification Tips

- For use with 24" – 60" (610mm – 1524mm) wide powered panels.
- Not for use with glass, translucent, perforated, or open stack kits.
- Wire harness length is 180" (4572mm).

Power Location

- Stack panels up to 120" (3048mm) high.

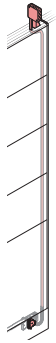

Stackable Panel: with Super Base Foundation Element

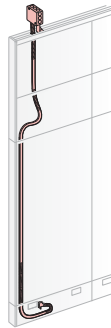

Stackable Panel: with Monolithic Foundation Element

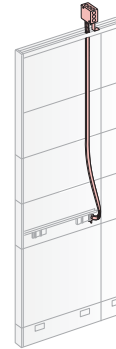

Stackable Panel: with Work-Height Power

Infeed Harness

The harness is used to transition building wiring to modular power within the furniture. One end is hardwired to building wiring and the modular end snaps into the power distribution assembly (PDA) in the furniture. This connection may be used to bring power in from the base or ceiling and can be used with open base panels.

Specification Tips

- For use with 24" – 60" (610mm – 1524mm) wide powered panels.
- For base applications, black split tubing may be field supplied to cover any exposed galvanized metal conduit.
- Not for use with glass, translucent, perforated, or open stack kits.
- Wire harness length is 180" (4572mm).

Power Location

- Floor
- Column
- Wall
- Ceiling

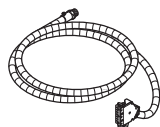

Infeed Harness

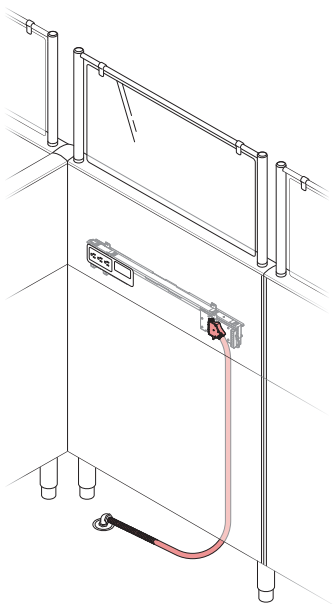

Open Base to Beltline

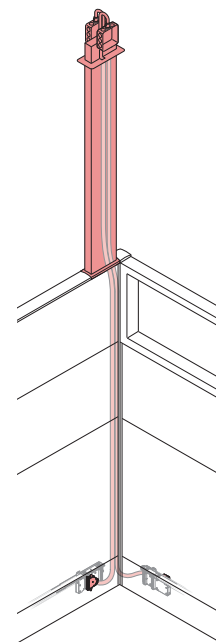

Two Harness Top Feed

Powered Panels

Base Power

Powered panels simplify planning power for a workstation. A powered panel includes a power distribution assembly (PDA) and a flex connector. The PDA is used to connect all other electrical components. The PDA has two connector ports at each end and two receptacle ports at each end. The connector ports on a PDA are used to span power to the next panel. The receptacle port is used for receptacles, base feeds, top feeds, and the vertical power connector.

Specification Tips

- For use with 24" – 60" (610mm – 1524mm) wide panels.
- Order extended power connector for 18" (457mm) wide panels.
- Order straight span connector for non-powered 3-Way or 4-Way conditions.
- Retrofit kits available to convert a non-powered panel to powered.
- Receptacle covers are included with powered raceway covers.

Powered Panel

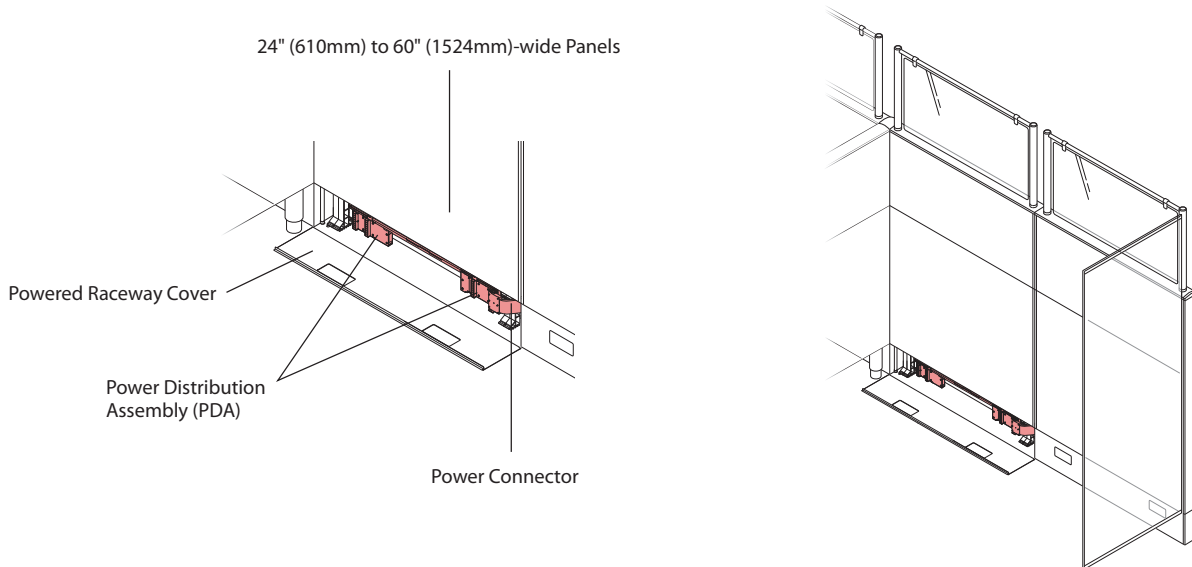

Power Distribution Assembly

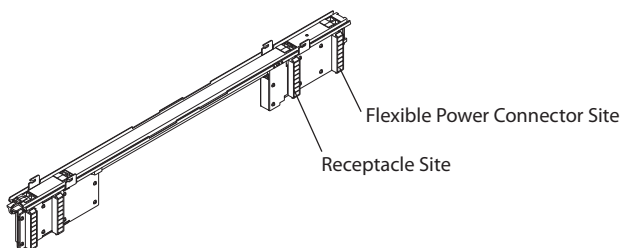

Flex Connector

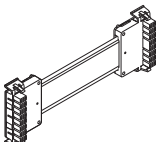

Base Raceway Cover

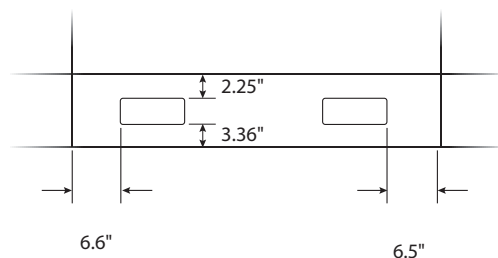

Note Refer to cable management section.

Power Kits

Work Height Power Kit

To place power in a work height location in PREMISE specify a powered stack kit and the desired pad types to finish the application. The stack kit provides a cross bar, cable trough, power distribution assembly (PDA) and flex connector. To access power with a receptacle in the PDA at work height specify a technology pad. If power is to pass through the location with no access required specify any non-technology pad.

Specification Tips

- For use with 24" – 60" (610mm – 1524mm) wide panels.
- No power pass-through for 18" (457mm) stack location. Power must be routed to the base to bypass an 18" (457mm) wide panel (see below).
- Order straight span connector for non-powered 3-Way or 4-Way conditions.
- Retrofit kits available to convert a non-powered stack to powered stack.

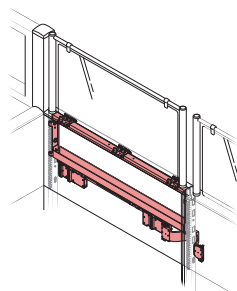

Powered Stack

18" (457mm) Panel/Pad

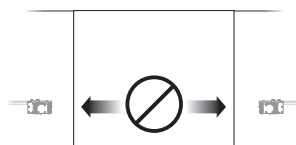

24" (610mm) Panel/Pad (No Power Access)

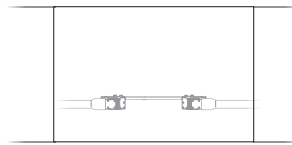

30" (762mm) Pad

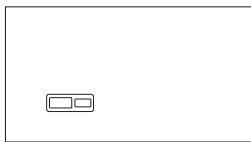

36"-60" (914-1524mm) Pad



Installed Heights

Measure from the bottom of the work height port to the bottom of the raceway cover.

- Beltline height power 34" (864mm) high
- Standing height power 50" (1270 mm) high
- Below Worksurface height power 18" (457mm)

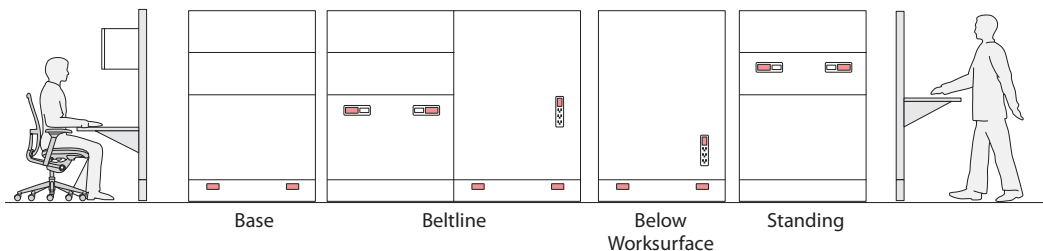

18" (457mm) Pass-Through

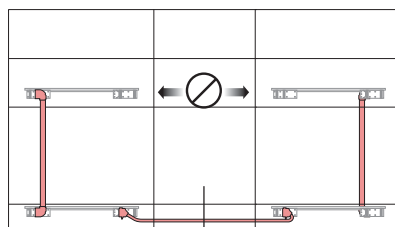

18" (457mm) Wide Panel

Power Kits

Structural Power Kit for Stack Application

Off-modular overheads must be supported by a structural cross bar and an off-modular pad. To place power in a work height location in PREMISE with an off-modular overhead specify a structural powered stack kit. The structural stack kit provides a structural cross bar, cable trough, Power Distribution Assembly (PDA) and flexible connector. To access power with a receptacle in the PDA at work height specify a slat technology pad. If power is to pass through the location with no access required, specify an off-modular pad.

Specification Tips

- For use with 24" – 60" (610mm – 1524mm) wide panels.
- No power pass-through for 18" (457mm) wide stack location.
- Order straight span connector for non-powered 3-Way or 4-Way conditions.
- Top feeds are not recommended for use on stack kits with structural crossbars.
- Retrofit kits available to convert a non-powered stack to powered stack.

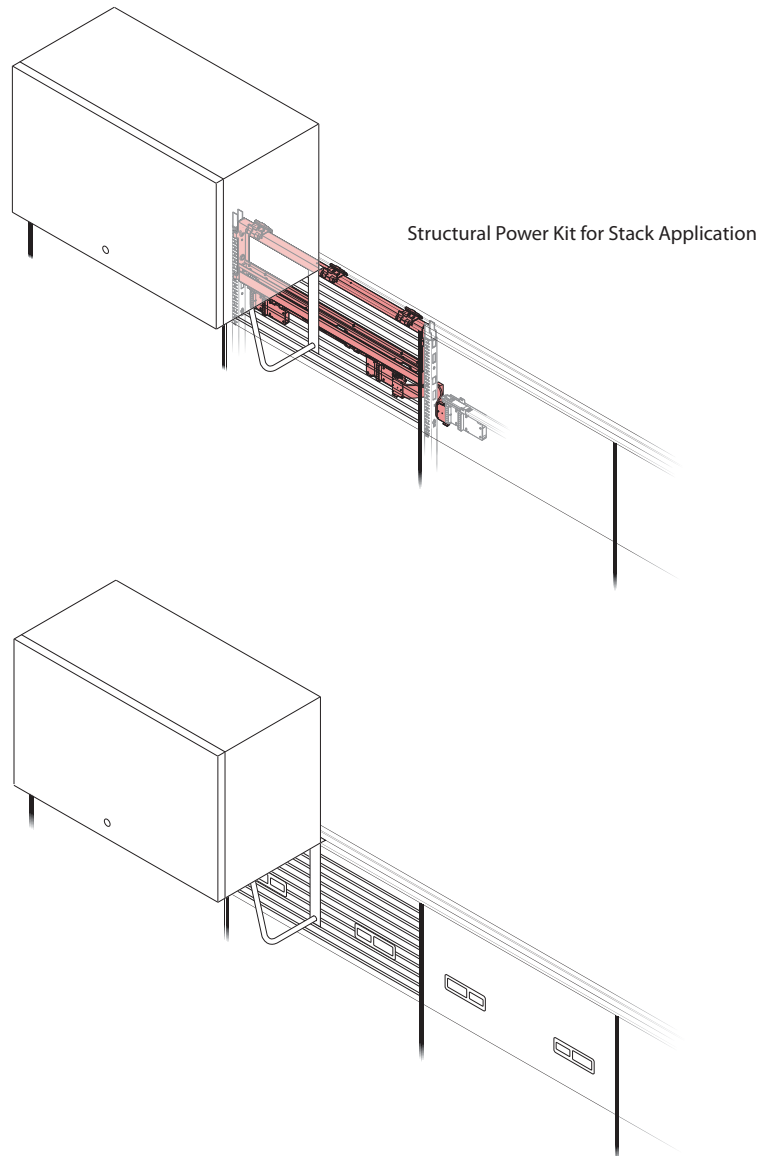

Power Connectors

Flexible Power Connector: Panel-to-Panel

The connector is used to span power from one powered panel to another adjacent powered panel. A power distribution assembly (PDA) and flexible connector are provided when a powered panel is ordered.

Specification Tips

- May be used in straight panel-to-panel, inside 90°, and inside 120° applications within the base raceway.
- Must be used with cable guides at stack levels for protection from hanging component.

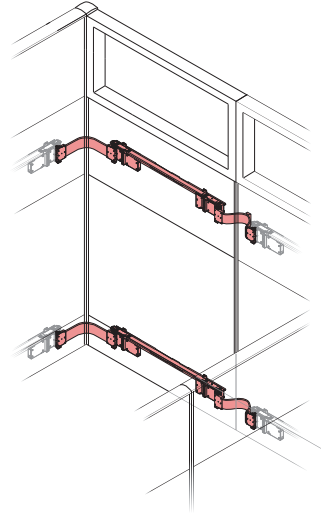
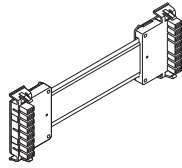

Straight Condition

Stack Kit Straight Condition

90° Condition

Stack Kit 90° Condition

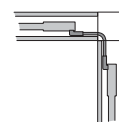
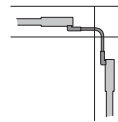
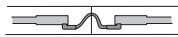
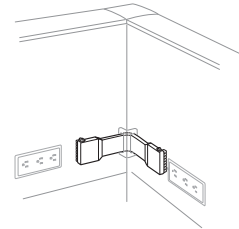
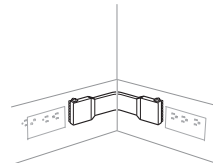
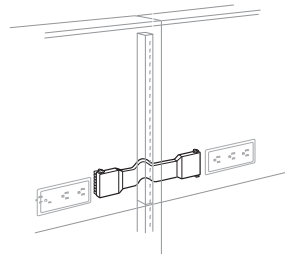
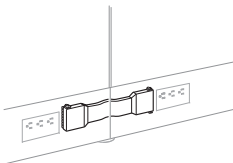

120° Condition

Stack Kit 120° Condition

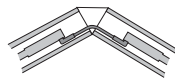
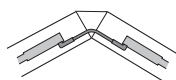
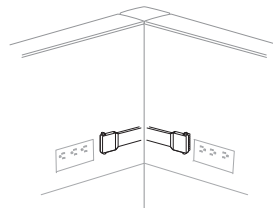
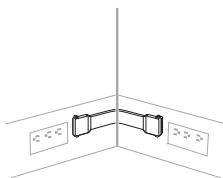

Power Connectors

Flexible Power Connector: Straight Span Raceway/Beltline

The connector is used to span power from one powered panel to another powered panel in an outside 90°, 3-Way, or 4-Way condition when return panels are non-powered. These connectors must be separately specified.

Specification Tips

- Must be used with cable guides at stack levels for protection from hanging components.
- May be used at base or work heights to span 3" space created by a 3-Way or 4-Way condition when return panels are non-powered.

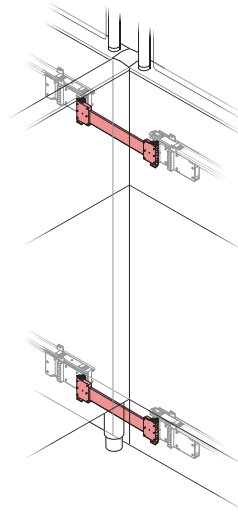
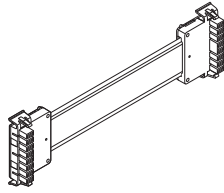

3- or 4-Way Condition

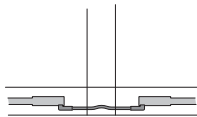
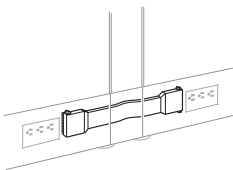

3- or 4-Way Condition

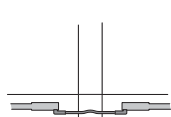
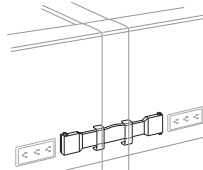

90° Condition

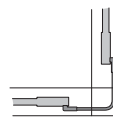
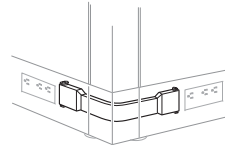

120° Condition

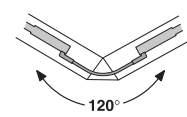
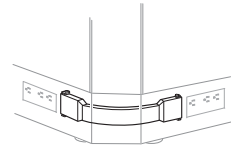

Power Connectors

Extended Power Connectors

The connector is used to route power through the base of one 18" (457mm) wide non-powered panel.

Specification Tips

- For use in base raceway only.
- Connectors cannot be coupled together.
- One length for all applications shown.

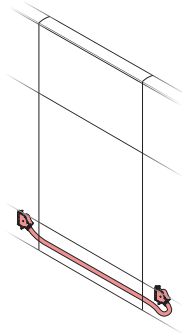
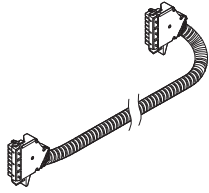

Straight Condition

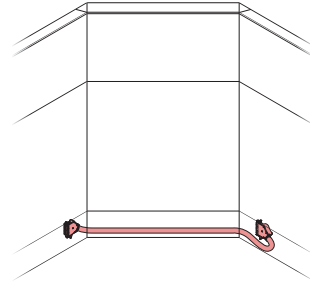

120° Condition

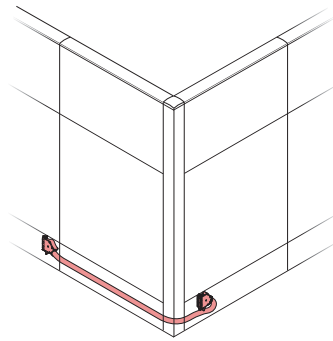

Corner Condition

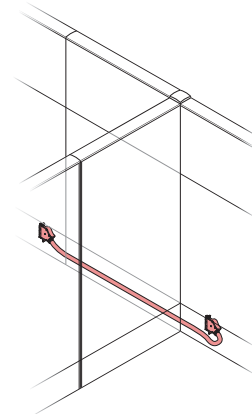

3-Way (shown) and 4-Way Condition

Power Connectors

Vertical Power Connector

These connectors route power vertically from the base to work height levels.

Specification Tips

- Cannot be used with monolithic panels, open, or glazed stack kits.
- Connectors block access to receptacle location at base and work height.

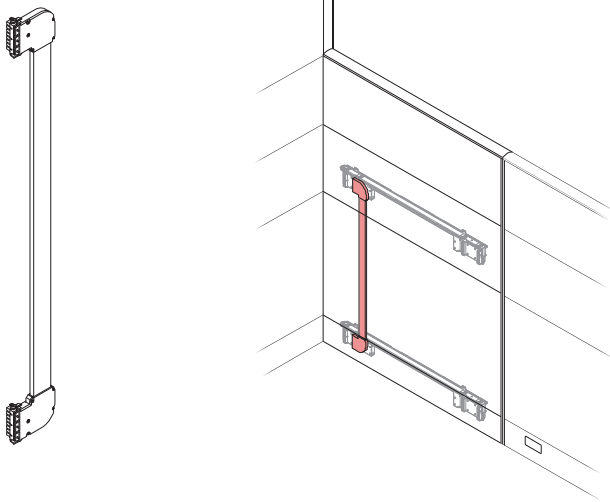

Beltline and Standing Height

- Installed height measures from the bottom of the work height port to bottom of raceway cover.

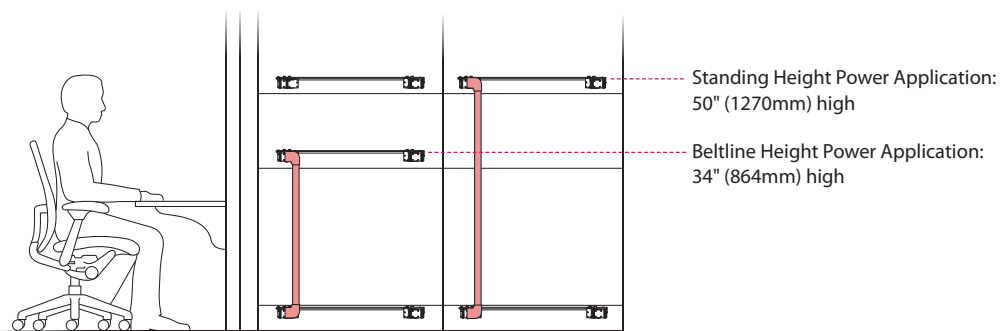

Receptacles

Receptacles

Receptacles attach to the power distribution assembly (PDA) to allow access to the circuits carried through a panel. The 3-Circuit 15 Amp receptacles have a circuit programmable feature that allows each receptacle to access either circuit 1, 2, or 3 in the field by simply sliding the connector to one of three positions.

Specification Tips

- 15 Amp receptacle configuration is NEMA 5-15R.
- 20 Amp receptacle configuration is NEMA 5-20R.
- 3-Circuit 20 Amp and 4-Circuit receptacles have fixed circuit access and are not field programmable. Specify appropriate number of receptacles for each circuit.
- Specify common ground or isolated ground.

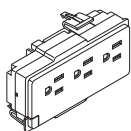

15 Amp

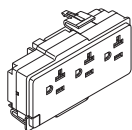

20 Amp

POWER CONFIGURATION	RECEPTACLE IDENTIFIER			
2+2	1	2	3	4
3+1	A	B	C	D
3-Circuit (20 amp)	I	II	III	NA

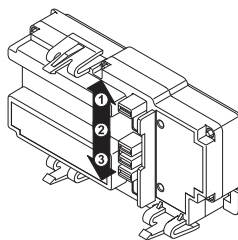

3-Circuit 15 Amp Programmable Receptacle

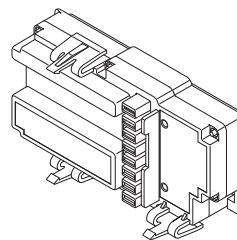

- 3-Circuit 20 Amp
- 4-Circuit 15 Amp
- 4-Circuit 20 Amp

Power/Communication Port Kit

Port kits provide a triplex receptacle and modular furniture telecommunications outlet at below worksurface and beltline level in monolithic panels.

Specification Tips

- Specification of circuit one, two, three, or four and ground type is required.
- Requires field modification of a powered panel.
- Modular furniture telecommunications faceplate must be field supplied.

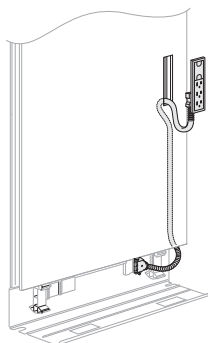
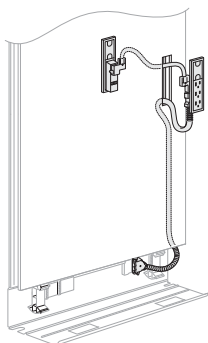

Receptacles

Desktop Port

Desktop ports provide three 15 Amp outlets and a modular furniture telecommunications outlet opening in a housing that can be clamped to the edge of a worksurface.

Specification Tips

- Power cord plugs into a panel or building receptacle outlet.
- Desktop ports cannot be linked (daisy chained) together.
- Cord use should be reviewed by local authorities (electrical inspector) prior to ordering.
- Modular furniture telecommunications faceplate must be field supplied.

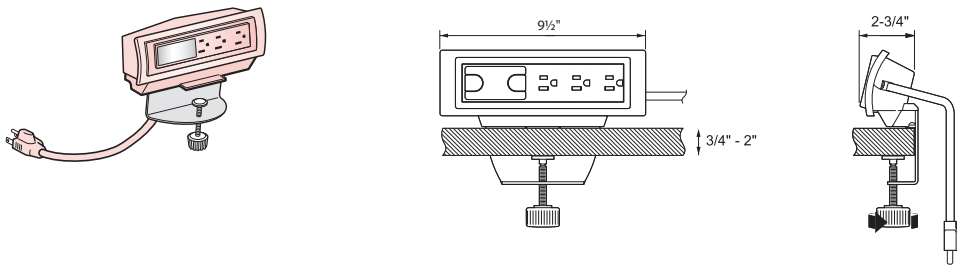

Flip Top Unit

Flip Top Unit provides 15 Amp outlets and data jacks in a desk top housing that flips up for access or can be closed for unobstructed work space.

Specification Tips

- Flip Top Unit must be field installed on worksurfaces by field cutting a hole.
- Hardwired applications should be reviewed by local authorities (electrical inspector) prior to ordering.
- Corded Flip Top Units with four receptacles utilize a fused plug that may block adjacent building receptacle outlet.

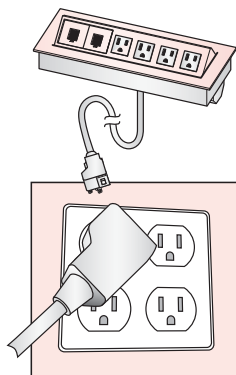
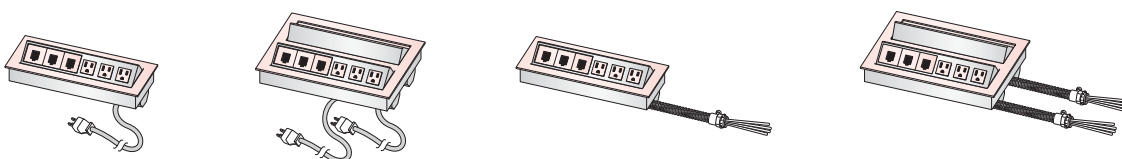

Fused Plug Detail
(for Flip Top Units with four or more outlets)

Flip Top Unit: Details

Flip Top Unit: Side Elevation

- Flip Top Unit: bezel and pop-up portion are proud to worksurface.
- When installed into a 1 $\frac{3}{8}$ " worksurface, the Flip Top Unit will extend below the worksurface.

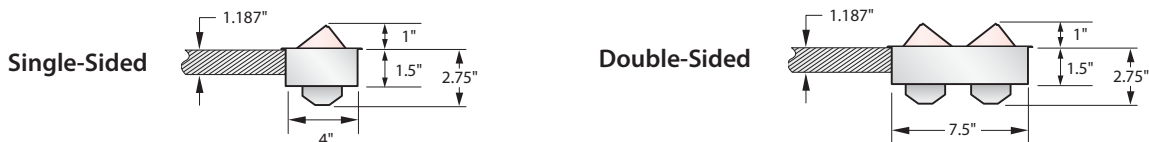

Flip Top Unit Bezel Dimensions:

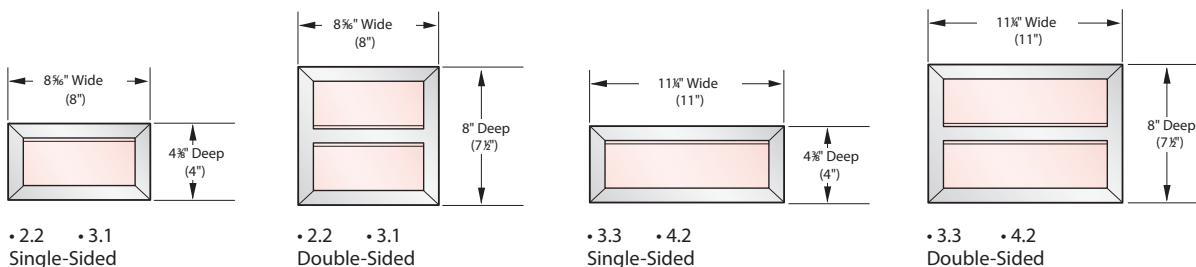

Note Cutout dimensions are in parentheses ().

The Flip Top Unit includes multiple data jack adapters to accommodate most field supplied data jacks. Also included are blank data covers to be used if no data access is needed. Data jacks are field supplied.

- 15 Amp rated simplex power receptacles
- Data information access ports

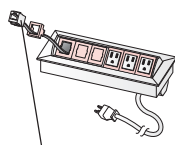

Data jack adapters standard in white; included with Flip Top Unit. (See manufacturer list for field supplied data jacks).

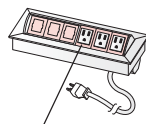

Perimeter edge of power receptacles and data ports faceplate standard in white.

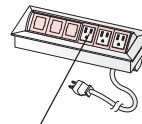

Simplex power receptacles standard in white; included with Flip Top Unit.

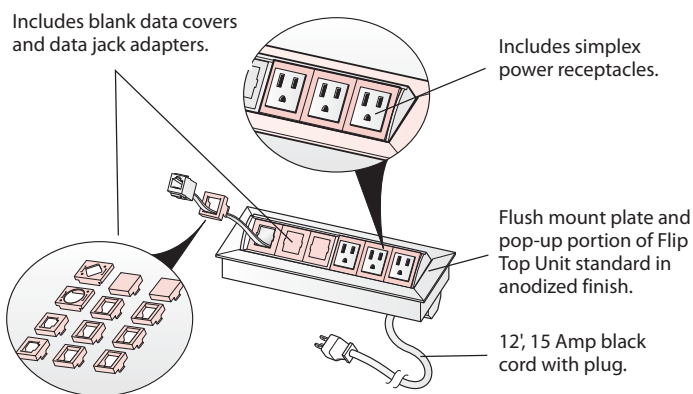

Data Jack Adapters Included

Manufacturer's List of Field Supplied Data Jacks

Systemax/CommScope
Tyco SL and 110 Connect Series Modular Jacks
Siemon Keystone Style
Allen Tel Versa Tap Series
Leviton Quick Port® Series
Nordx Keystone Style
Tyco SL Coupler Series
ADC (Krone) 6000 Series
Hubbell Xcelerator™ Keystone Series
Blank (no coupler/jack)
Ortonics TracJack Series
Panduit Mini-Com Series
Microphone Jack/3-Pin XLR (solder type only)
Video Monitor Jack/DB-15 (panel mount solder style)

Power Basics

3-Circuit

- As many as three separate 20-Amp rated circuits from one power feed module.
- 8-Wire system enclosed in one power distribution assembly:
 - 3 hot wires
 - 3 neutral wires
 - 1 common ground wire
 - 1 isolated ground wire
- Separate neutrals, one dedicated to each circuit, are capable of carrying computer-quality power.

4-Circuit

- As many as four 20-Amp rated circuits from one power feed module.
- 8-Wire system enclosed in one power distribution assembly:
 - 4 hot wires
 - 2 neutral wires
 - 1 common ground wire
 - 1 isolated ground wire
- 4-Circuit product is available in either a 2+2 configuration or a 3+1 configuration. Both configurations utilize a shared neutral conductor for at least two circuits. All circuits have access to either common or isolated ground.

Hardwire

- Components available to meet Chicago and other similar hardwire configurations.
- Consists of infeeds, junction boxes, and mounting hardware.
- Field supplied wire and receptacles allow for a variety of applications for specific needs.

Panel Power Options:

- 3-Circuit and 4-Circuit: Panel options specified with 3- or 4-Circuit power include a power distribution assembly and a flex connector.
- New York City (NYC): The New York City option includes the same components as those listed above but are shipped separate from the panel and require field installation.
- New York Port Authority (NYPA): The New York Port Authority option includes a metal raceway cover and is available with or without the power components.
- Hardwire: The hardwire option includes raceway covers for receptacle access. Hardwire electrical raceway kits and receptacle covers must be separately specified. In addition, receptacles, conduit, wiring, and other associated components must be field supplied.

3- and 4-Circuit Overview

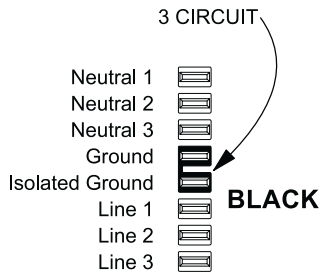

3-Circuit/Separate Neutrals

This option provides three circuits, each with its own neutral.

- Aligns with the 3 phase national power grid and most North American buildings.
- Is compatible with the following building power configurations:
 - 3 phase (208Y/120V)
 - Three wire single phase (120/240V)
 - Single phase (120V)
- Offers the most adaptability to special power needs such as:
 - multiple power sources
 - facility energy control
 - isolation of high harmonic loading
- Features receptacles with patented on-site circuit access programmability (available only on Power Base for furniture).
- Offers receptacles in common ground or isolated ground configurations.

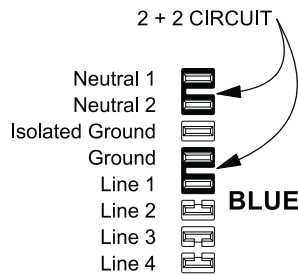

4-Circuit/2+2

This option provides four circuits, two circuits share neutral #1, two circuits share neutral #2.

- Provides more circuits (4 vs. 3) for each homerun from the electrical closet, which can reduce the installed cost per circuit.
- Is compatible with the following building power configurations:
 - 3 phase (208Y/120V)
 - Three wire single phase (120/240V)
- Is sometimes less adaptable to special power needs such as multiple power source or facility energy control.
 - Special power needs are typically planned in sets of two circuits
 - In some cases, 10 gauge shared neutral may not fully isolate circuits
- Modular receptacles have fixed circuit access.
- Offers receptacles in common ground or isolated ground configurations.

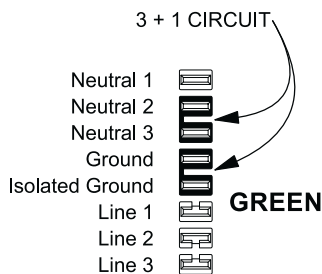

4-Circuit/3+1

This option provides four circuits, three circuits share neutral #1, circuit #4 has a separate neutral.

- Provides more circuits (4 vs. 3) for each homerun from the electrical closet, which can reduce the installed cost per circuit.
- Is compatible with the following building power configurations:
 - 3 phase (208Y/120V)
- Is sometimes less adaptable to special power needs such as multiple power source or facility energy control.
 - Special power needs are typically planned only using circuit #4
 - In some cases, 10 gauge shared neutral may not fully isolate circuits
- Modular receptacles have fixed circuit access.
- Offers receptacles in common ground or isolated ground configurations.

Power Planning General Guidelines and Checklist

All power application information is found in the corresponding component Price List, system-specific specification guide, and Power Base Planning Guide.

Verify the Following:

In: Routing power from the building into the furniture.

- Power feed length will reach building location.
- Infeed fits panel width.
- Infeed location is not occupied by a:
 - Receptacle
 - Horizontal Connector (attaches to receptacle location on PDA)
 - Vertical Connector
 - Port Kit Connector (attaches to receptacle location on PDA)
- Power raceway cover for external infeed location.

Through: Routing power through the furniture.

- Power distribution assemblies (PDAs) are located where power access is needed.
 - Base power is specified with the base panel.
 - Beltline and standing height power are specified with power kit or structural power kit for stack application.
- Horizontal Power Routing:**
 - Base Power
 - Spanning connector for each 3-Way/4-Way connection where return panels are non-powered.
 - Extended power connector for each 18" (457mm) panel.
 - All adjacent panels have base power, 18" (457mm) power connectors cannot be coupled together.
 - Work Height Power
 - Spanning connector for each 3-Way/4-Way connection where return panels are non-powered.
 - Work height power is only routed through panels 24" (610mm) wide or greater.
- Vertical Power Routing**
 - Correct Vertical Power Connector length is specified for work height application.
 - Vertical power connector passes through a Super Base panel.

Out: Getting power out of the furniture so it can be used.

- Maximum receptacle quantity per infeed is not exceeded (13 United States/10 Canada).
- Fixed circuit receptacles are specified for all circuits.
- Ability to access power through base raceway receptacle port or technology pad.
- Power/communication port kit is used in a powered monolithic panel.

General Power Application Guidelines:

- Power break markers are indicated where needed.
- Other accessories do not block receptacles access.
- Panel hung components and floor-supported storage do not block receptacle access.
- Do not mix 3-Circuit or 6-Circuit with 4-Circuit components.
- Do not mix 2+2 and 3+1 components.
- Components have unique polarity key and color coding (3-Circuit = black, 6-Circuit = ivory, 2+2 = blue, and 3+1 = green).

Power Distribution for Hardwire Applications

Hardwire power applications are designed to address non-modular power planning solutions.

1. Power distribution from building-to-panel.
2. Vertical power distribution.
3. Horizontal power distribution.

Infeeds	Applications
1 Base Feed	48" (1219mm) or as required
2 Top Feed	Ceiling Height (H) + 18" (457mm)

Panel Applications	Panel Applications
3 Between two junction boxes on one panel	Panel Width (W) – 23" (584mm)
4 Passing through a panel	Panel Width (W) + 12.50" (318mm)
5 Across 3- or 4-Way connection (to adjacent boxes)	16.50" (419mm)
6 Base to work-height	44" (1118mm)
7 Work-Height/work-height	88" (2235mm)
8 Base to standing-height	60" (1524mm)

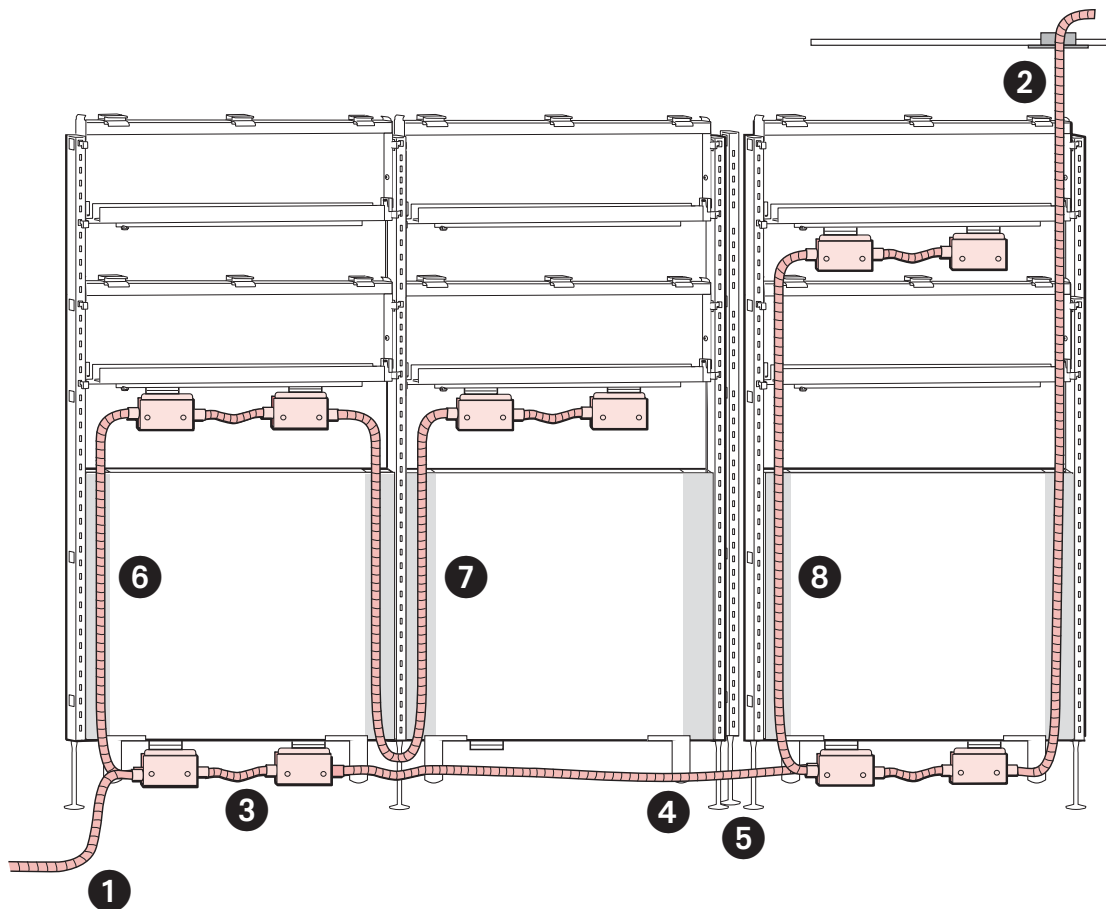

Tip Conduit and receptacle are field supplied.

International Power Management

International Power Planning

For power applications outside North America, we recommend the use of Power Logic soft wiring components. Power Logic offers a system of single circuit power cords and receptacle modules that fit into our non-powered Base Raceway. Receptacle Modules are offered with two sockets (three and four socket versions also available). Each Receptacle Module has sockets, switches, and fuses that are appropriate for each country around the world.

- Use a Power Entry Cord to bring power into the Panel's Base Raceway and feed a Receptacle Module mounted to the Base Raceway Cover.
- Use additional Cords to route power to additional receptacles as needed.
- Use a Splitter to branch out in multiple directions (up to four).

Contact the Power Logic regional sales office in your area to help with planning details to assure local electrical code compliance. Contact Power Logic through their website, www.powerlogic.net, or through their corporate offices in Cape Town, South Africa at 27-21-704-1450. Power Logic also offers power solutions for desk top, conference table, or freestanding power applications.

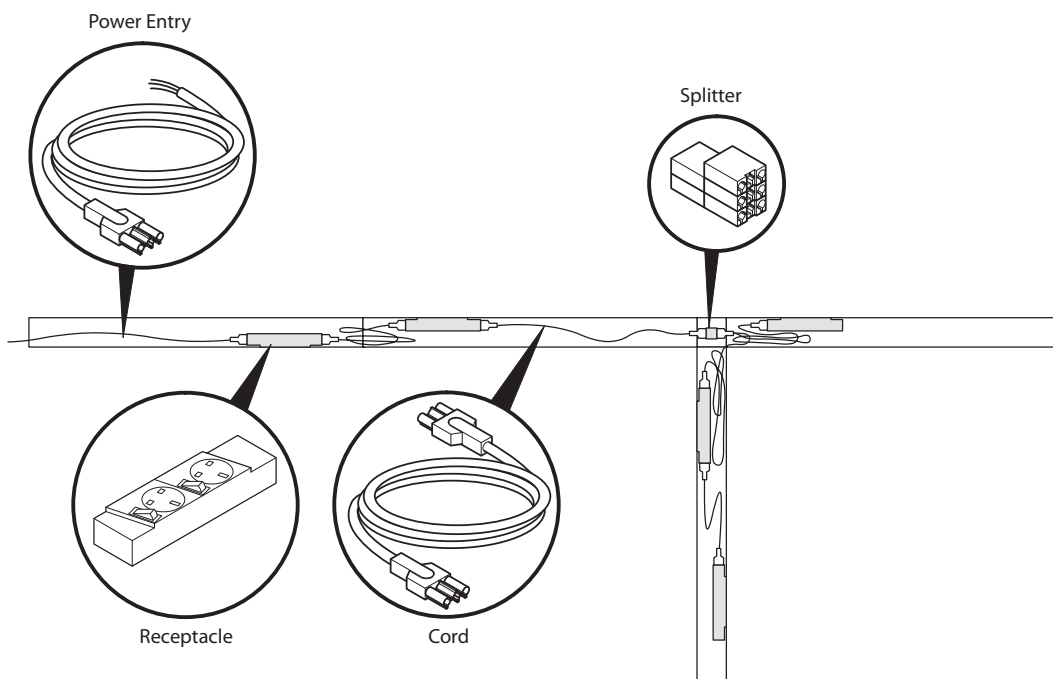

Cable Management: Introduction

PREMISE addresses the distribution of communications cables with panel-integrated cable pathways and access points.

Cables can be routed through these pathways:

- Panel Base Pathway
- Monolithic Panel Top Pathway
- Monolithic Panel Vertical Pathway (one on each side)
- Stack Kit Cable Trough
- Space between Super Base Panel and Pads: ½" (13mm) each side
- Space between Stack Kit Pads and Connectors
- Top Feed Vertical Raceway

Cables can be accessed at these locations:

- Base Raceway Covers with Communication Ports must be separately specified.
- Stack Kit Communication Ports
- Monolithic Panel Communications Port Kit
- Desktop Port/Flip Top Unit Communication Port

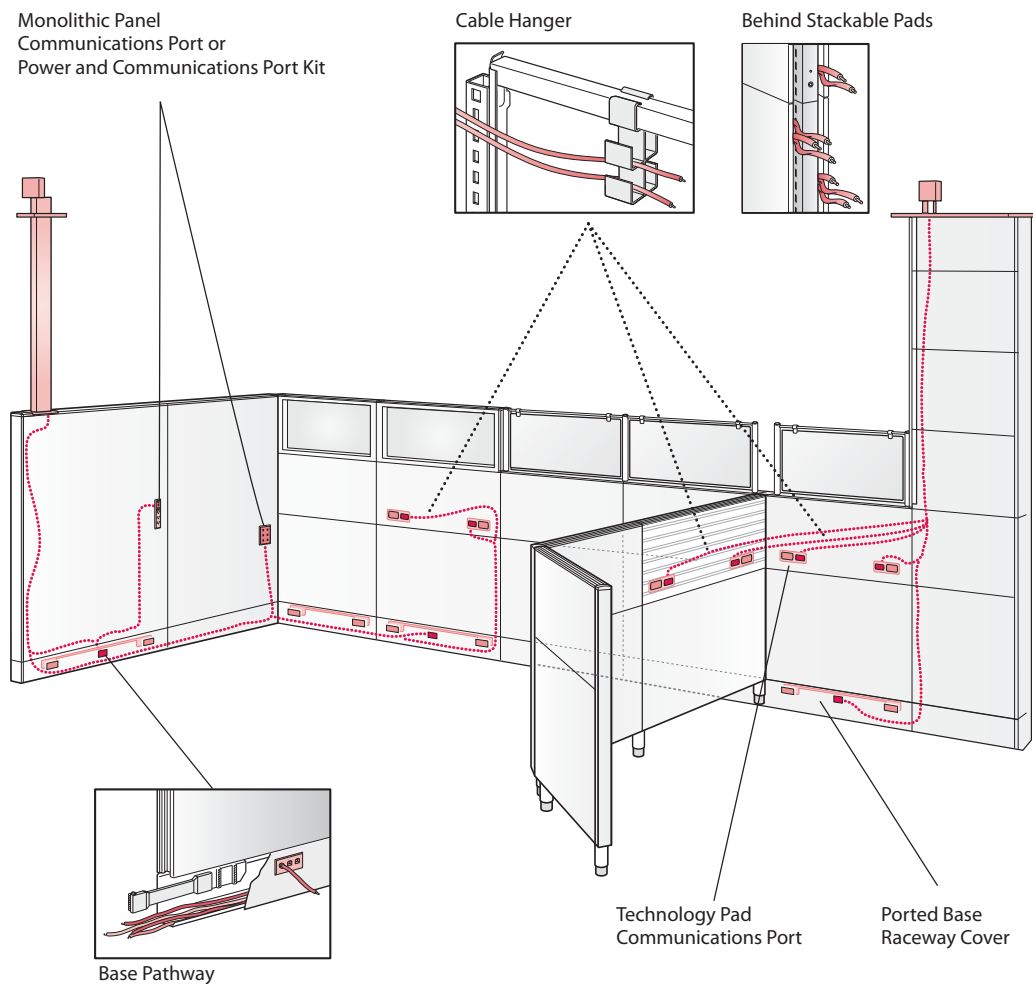

Note Route cables at base pathway or at stack location when using Grooved Top Cap.

Base Raceway: Communication Options and Dimensions

Raceway with Modular Furniture Telecommunications Outlet

PANEL WIDTH	"A" MEASUREMENT
30" (762mm)	13.65" (347mm)
36" (914mm)	13.47" (342mm)
42" (1067mm)	16.47" (418mm)
48" (1219mm)	19.47" (494mm)
60" (1524mm)	25.47" (647mm)

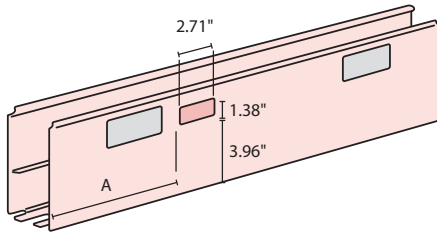

Single-Sided Base Raceway

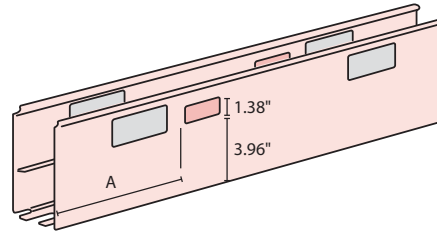

Double-Sided Base Raceway

Raceway with Single-Gang Communication Access Opening

PANEL WIDTH	"A" MEASUREMENT
30" (762mm)	13.1" (333mm)
36" (914mm)	14.5" (368mm)
42" (1067mm)	17.5" (444mm)
48" (1219mm)	20.5" (521mm)
60" (1524mm)	26.5" (673mm)

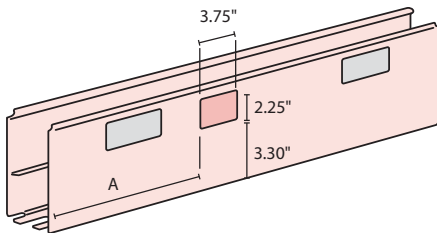

Single-Sided Base Raceway

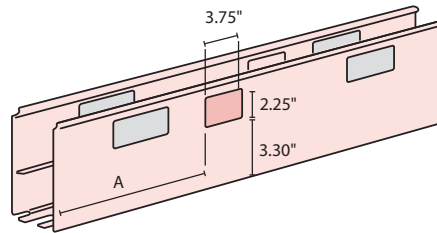

Double-Sided Base Raceway

The following manufacturers offer faceplates that fit modular furniture telecommunications openings. For additional details, contact your local Haworth Technical Representative.

- Systemax/CommScope
- Tyco
- Siemon
- Leviton
- ADC
- Hubbell
- Belden
- Ortonics
- Panduit
- Hubbell

Data Access: Data Brackets

- Up to four sites per work-height application (two per side).
- For use with modular furniture telecommunications plate.
- Data brackets must be installed at all work-height applications.
- Data blank plates are required when modular furniture telecommunications faceplates are not used:
Single Technology Pad ships with enough blank plates to fill pad openings.

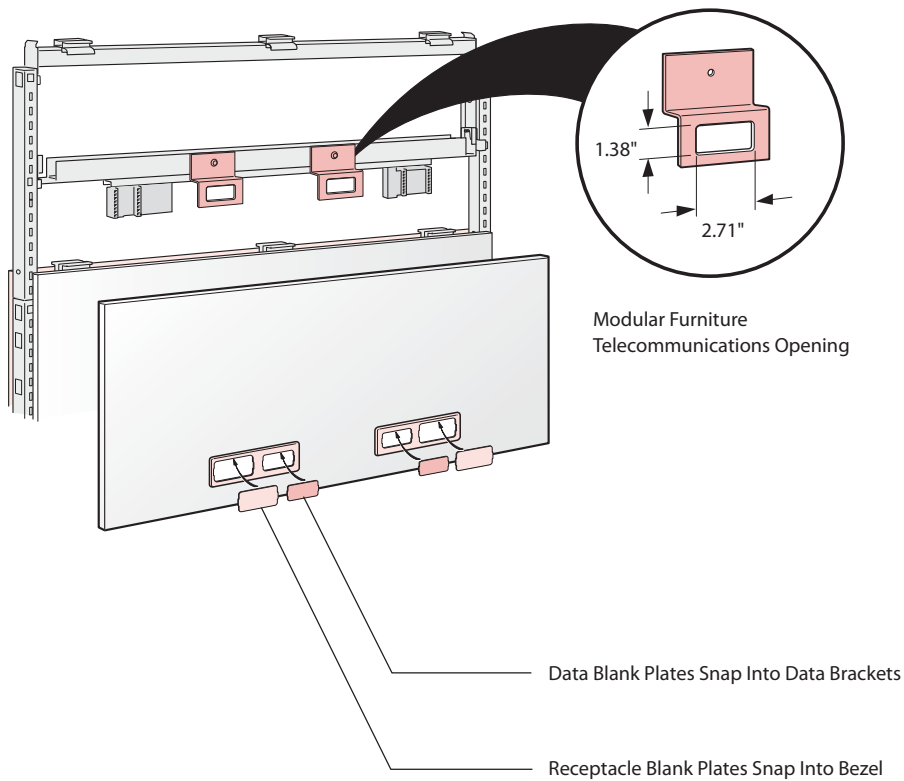

Cable Management

Cable Accessories

Power kits are provided with communications accessories to manage the direction of the cables within the panel configuration. Additional accessories may be ordered as needed. Accessories include:

- Cable Trough (NEC4)
- Cable Hanger (NECH - 1)
- Vertical Cable Guide (NECG - V)
- Cable Reel (NECR - 1)
- Straight Cable Guide (NECG - S)
- Corner Cable Guide (NECG - C)

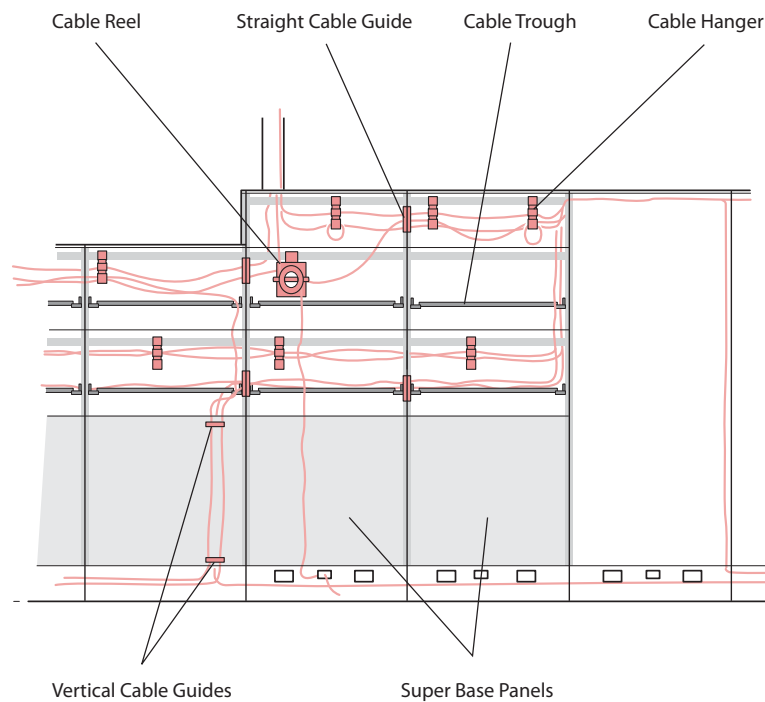

Tip Modular furniture telecommunications outlet and single gang data port openings are available offset left from the center raceway cover when specified.

Cable and power management accessories are provided only with power kits as shown below. Order additional accessories as needed.

STACK APPLICATION ACCESS TYPE	POWER CABLE	MANAGEMENT ACCESSORIES
Power and Communication	3-Circuit	2 Cable Hanger, 3-5" (76-127mm) straight cable guide, 1-5" (25-127mm) corner cable guide, 1-3" (25-76mm) straight cable guide, 1-3" (25-76mm) corner cable guide
Power and Communication	4-Circuit	2 Cable Hanger, 3-5" (76-127mm) straight cable guide, 1-5" (25-127mm) corner cable guide, 1-3" (25-76mm) straight cable guide, 1-3" (25-76mm) corner cable guide

- Notes**
- Components hung at stack heights may interfere with cable routing and cable guides. Components prevent the use of cable guides if used at same level.
 - For external routing of cables use NEV-1 and NEV-2.

Cable Management

Cable Bend Radius

When planning the routing of communications cables through PREMISE panels, the bend radius at the panel-to-panel connections and within the panel pathways should be taken into consideration.

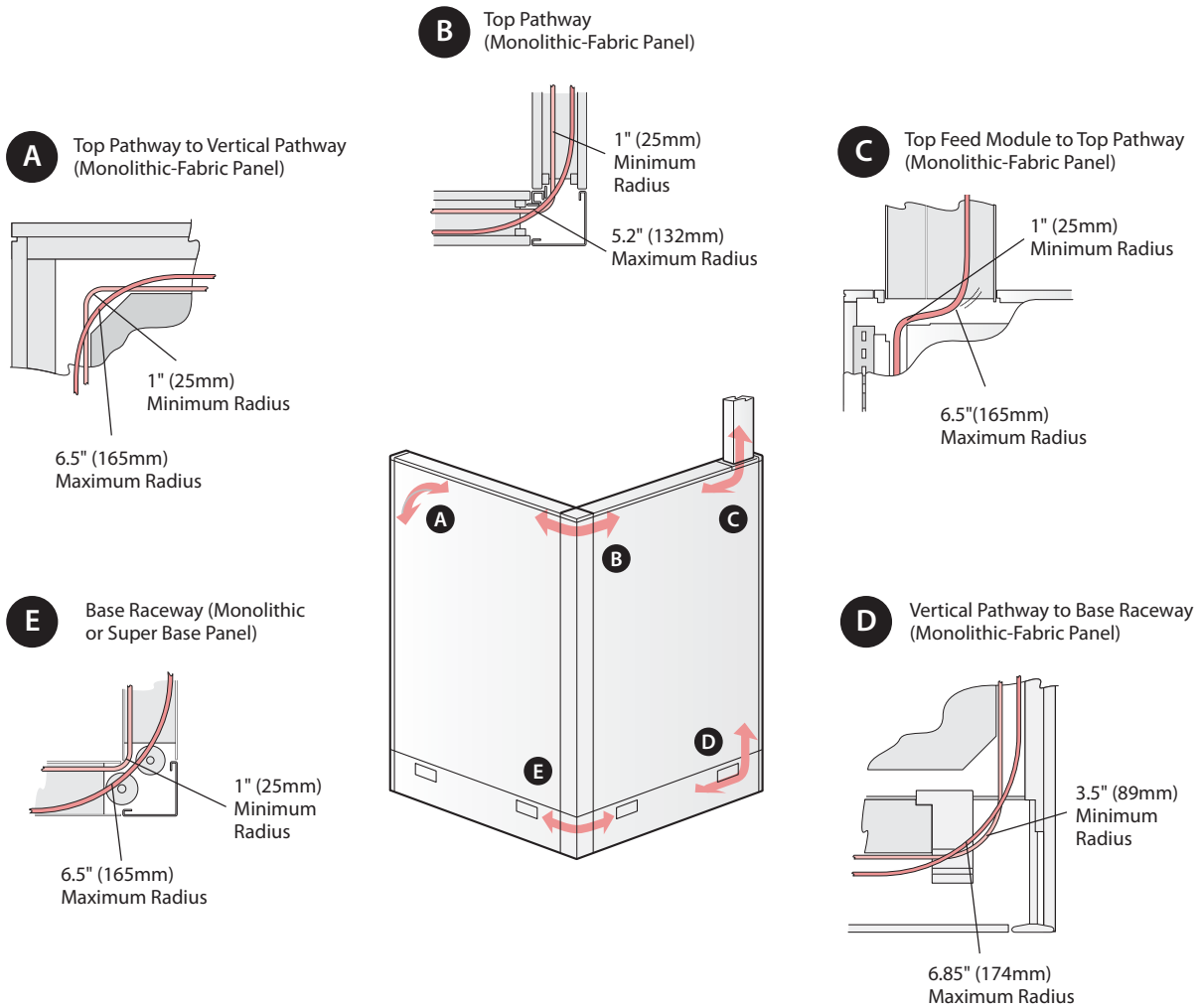

Stack Kit Application

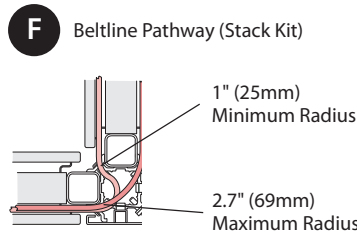
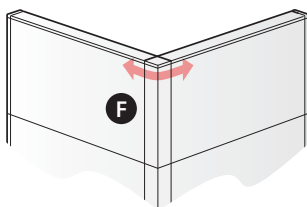

Note Route cables at base raceway or at stack location when using Grooved Top Cap.

Cable Management

Cable Capacities

This chart shows the number of communication cables that can be routed through specific pathways. Cable capacities are based on 0.20" (5mm) and 0.28" (7mm) and 0.30" (8mm) diameter cables at 60% and 40% fill capacity. TIA/EIA 569A suggests a cable fill of 40% for planning and up to 60% for unplanned additions.

PREMISE Pathway Capacities	Cable Pathway Area		Cable Capacity					
	SQ. IN.	SQ. MM.	60% FILL			40% FILL		
			0.20" (5MM)	0.28" (7MM)	0.30" (8MM)	0.20" (5MM)	0.28" (7MM)	0.30" (8MM)
Example								
One Square Inch Pathway	1.0	645	19	10	8	13	6	6
Monolithic Panel Pathways								
Base Pathway, Powered	6.0	3871	115	53	51	76	39	34
Base Pathway, Non-Powered ¹	6.0	3871	115	58	51	76	39	34
Monolithic Vertical Pathway at Panel Lock ²	1.7	1097	32	17	14	22	11	10
One Vertical Pathway (2 per panel)	2.8	1806	54	27	24	36	18	16
Top Pathway (within panel)	2.5	1613	48	24	21	32	16	14
Top Pathway (with light block restriction) ³	1.6	1032	31	16	14	20	10	9
Super Base Panel Pathways								
Base Pathway, Powered	6.0	3871	115	58	51	76	39	34
Base Pathway, Non-Powered ¹	6.0	3871	115	58	51	76	39	34
One Vertical Pathway (2 per panel)	1.3	839	25	13	11	17	8	7
Stack Kit Cable Trough (1.5" x 1.4" nominal)	2.1	1355	40	20	18	27	14	12
Stack Vertical 90° Corner Trim (1.8" x 1.8")	3.2	2065	61	31	27	41	21	18
Top Feed Modules								
Top Feed Module 3- and 4-Circuit (Stack) ⁴	7.2	4645	138	70	61	92	47	41
External Top Feed Module 3- and 4-Circuit	4.5	2903	86	44	38	57	29	25
Stack Kit Cable Guides								
Vertical Cable Guide NECG-V (2½" x ⅝")	0.7	452	13	7	6	9	5	4
Straight NECG-3-S (3" x ⅜" nominal)	1.1	710	21	11	9	14	7	6
Straight NECG-5-S (5" x ⅜" nominal)	1.8	1161	34	18	15	23	12	10
Inside Corner NECG-3-C (.95 bend radius)	Same cross-section as NECG-3-S, but tight bend radius.							
Inside Corner NECG-5-C (.95 bend radius)	Same cross-section as NECG-3-S, but tight bend radius.							
Cable Hanger NECH-1 (4-cavity 1.1" x 1.1" ea.)	4.8	3097	92	47	41	61	31	27
Worksurface Wire Manager H-loop NEH-8	3.4	2194	65	33	29	43	28	19
Vertical Wire Manager NEV-1	0.3	194	6	3	3	4	2	2
Vertical Wire Manager NEV-2	Intended for a single task light cord							

¹ Non-powered provides no additional cable capacity than powered.

² On Monolithic Panels the honeycomb can be crushed to allow cable to route around the panel lock.

³ The light block at the panel intersection can be cut or modified to match the top pathway fill capacity.

⁴ Top Feed cable capacity on Monolithic panels is greater than the panel capacity. For Monolithic panels cable capacity will be equal to one Vertical Pathway and one Top Pathway (provides access to second Vertical Pathway). For Super Base Panels and Stack Kits, the area for routing cables is limited to 0.4" (10mm) area between the pads and cross-bars or top of panel. The numbers provided in the chart reflect this restriction.

- Notes**
- Route cables at base raceway or at stack location when using Grooved Top Cap.
 - Mock-up of cables is more accurate than these mathematical calculations due to rounding error.



This page intentionally left blank.



This page intentionally left blank.

Power and Communication: Introduction

The Compose system accommodates all power and cable management needs through the Power Base electrical distribution system and multiple cable pathways. Power Base is a modular electrical system available in the base raceway and at work-height (below worksurface beltline and standing height). Power Base is offered in 3-Circuit and 4-Circuit (2+2 or 3+1) configurations. Power Base components are designed to address three functions:

1. **In:** Routing power from the building into the furniture.
2. **Through:** Routing power through the furniture.
3. **Out:** Receptacle access at panel.

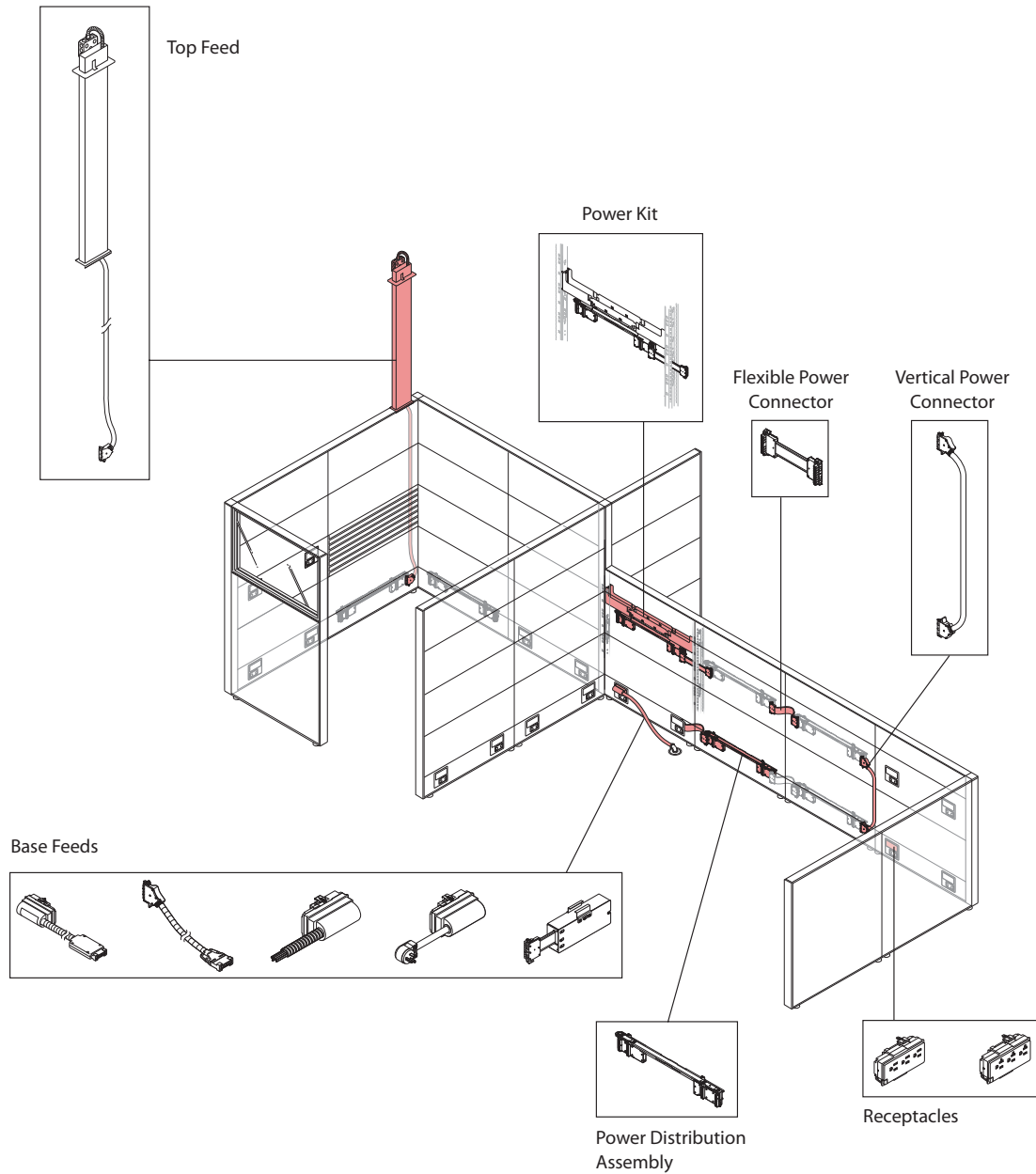

Power Statement of Line

In: Building to Panel

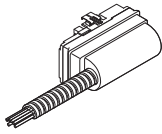

Base Feed Module:
Hardwire Connection

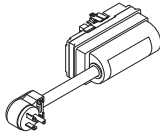

Single Circuit Base Feed Module:
Receptacle Connection with Power Cord

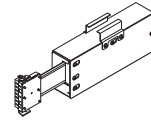

Base Feed Module: Concealed
Hardwire Connection

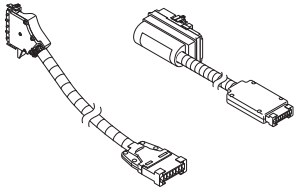

Power Base AI Feeds



Top Feed Module

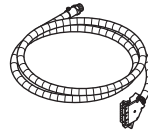

Infeed Harness

Through: Power Distribution

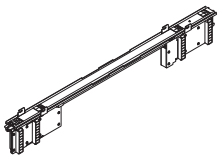

Power Distribution Assembly

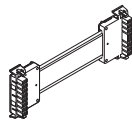

Flexible Power Connector



Vertical Power Connector

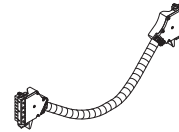

Extended Connector

Out: Receptacle Access

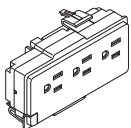

15 Amp Receptacle

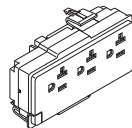

20 Amp Receptacle

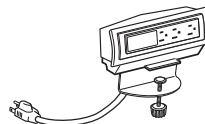

Desktop Port

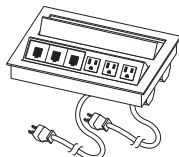
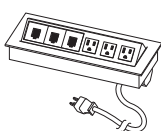

Flip Top Unit

Base Feed Modules

Base Feed Module: Hardwire Connection

The module is used to transition from building wiring to modular power within the furniture. One end is hardwired to the building wiring and the modular end snaps into the power distribution assembly (PDA) in the base of the furniture.

Specification Tips

- For use with 24"-60" (610mm-1524mm) wide powered panels.
- Not for use with tile to floor panels.
- May be used when routing power from Compose into Enclose or Patterns.
- Specify Architectural Power on the Compose Panels used to route power into Patterns or Enclose.

Power Location

- Floor
- Column
- Wall

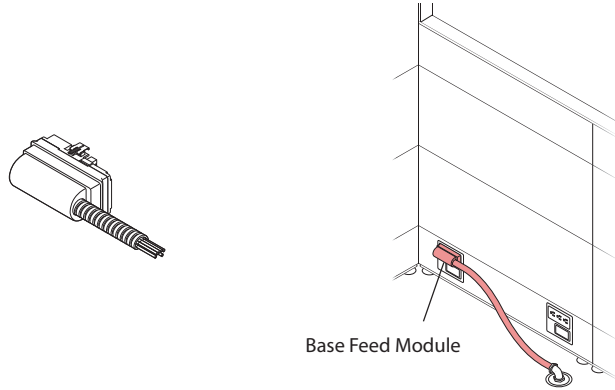

Single Circuit Base Feed Module: Receptacle Connection with Power Cord

The module is used to transition from building wiring to modular power within the base of the furniture. The cord end is plugged into a receptacle (NEMA 5-20R USA/NEMA 5-15R Canada) in the building and the modular end snaps into the power distribution assembly (PDA) in the furniture. Only circuit one is powered by a cord feed. This feed is used for small furniture clusters such as a reception desk. National codes restrict the length of the cord; 24" (610mm) in United States, 72" (1829mm) in Canada.

Specification Tips

- For use with 24"-60" (610mm-1524mm) wide powered panels.
- Not for use with isolated ground receptacles.
- Not for use with tile to floor panels.
- Not for use when routing power from Compose into Enclose or Patterns.

Power Location

- Floor
- Wall

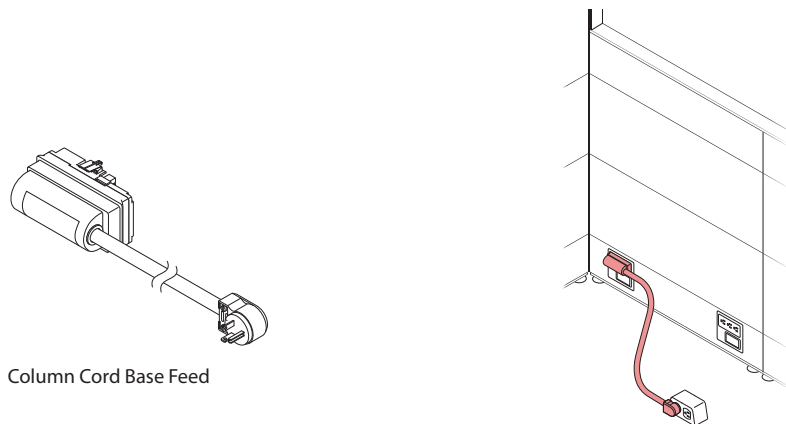

Base Feed Modules

Base Feed Module: Concealed Hardwire Connection

The module is used to transition building wiring to modular power within the furniture. The module's junction box is mounted to the furniture and its modular connector snaps into the power distribution assembly (PDA). Field supplied conduit is used to bring power from the building to the junction box, allowing for some versatile applications. Although used primarily to meet New York City code requirements for a base-fed infeed, it is not limited for use in this locale.

Specification Tips

- For use with 36"–60" (914mm–1524mm) wide powered panels.
- Not for use when routing power from Compose into Enclose or Patterns.

Power Location

- Floor
- Column
- Wall

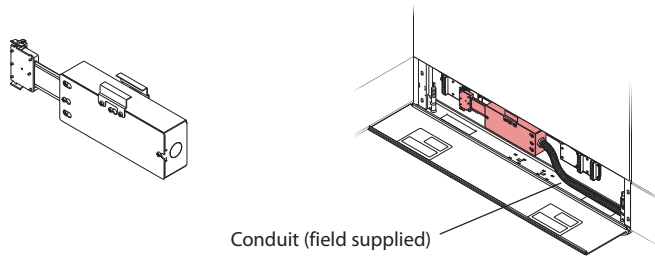

Note New York City code compliant.

Raised Floor Infeed Base Feed Module: External and Internal

These modules are used to make plug-and-play connections between Power Base AI underfloor modular power and Power Base modular power in furniture. Internal version can enter under the panel base so base feed is not visible. The conduit of the external version will be exposed but allows flexibility in positioning of the furniture.

Specification Tips

- For use with 24"–60" (610mm–1524mm) wide powered panels.
- External feed not for use with tile to the floor panel applications.
- Can only be connected to Power Base AI underfloor power system.
- May be used when routing power from Compose into Enclose or Patterns.
- Specify Architectural Power on the Compose Panels used to route power into Patterns or Enclose.
- Black split tubing may be field supplied to cover any galvanized metal conduit.

Power Location

- Power Base AI

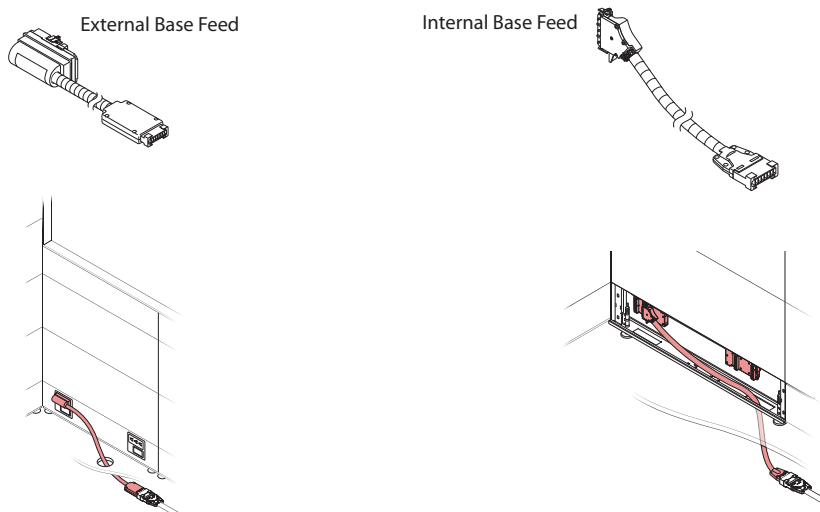

Base Feed Modules

Base Feed Module: Architectural Concealed Hardwire Connection

The module is used when feeding power through Compose panels to Patterns or Enclose. The module is used to transition building wiring to modular power within the furniture. The module's junction box is mounted to the furniture and its modular connector snaps into the power distribution assembly (PDA). Field supplied conduit is used to bring power from the building to the junction box, allowing for some versatile applications. Although used primarily to meet New York City code requirements for a base-fed infeed, it is not limited for use in this locale.

Specification Tips

- For use with 36"– 60" (914mm–1524mm) wide powered panels.
- Specify Architectural Power on the Compose Panels used to route power into Patterns or Enclose.
- See Patterns and Enclose Specification Guides for application details.

Power Location

- Floor
- Column
- Wall

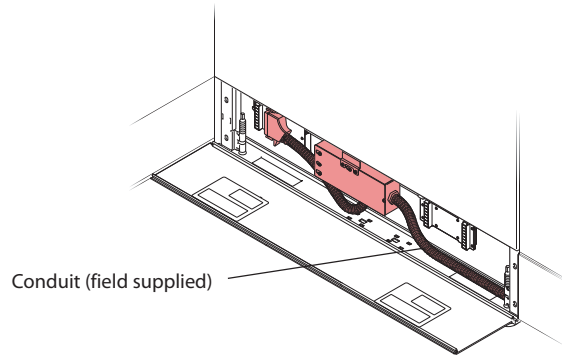
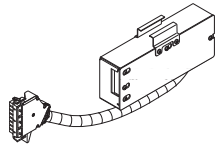

Compose Powering Patterns

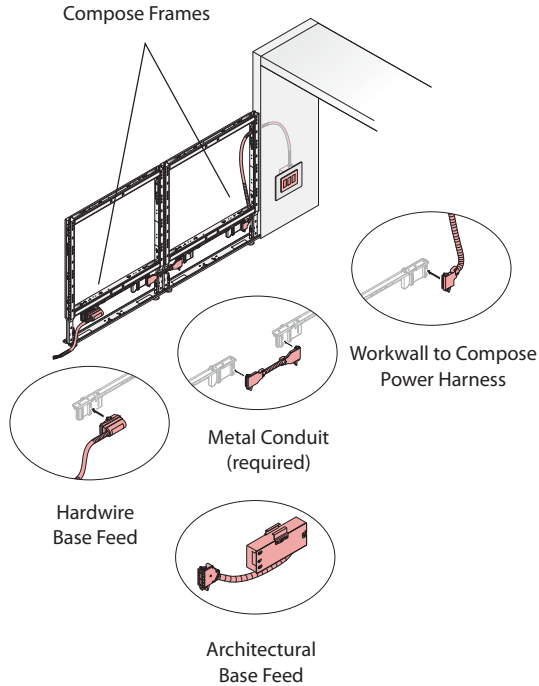

Note New York City code compliant.

Patterns Powering Compose

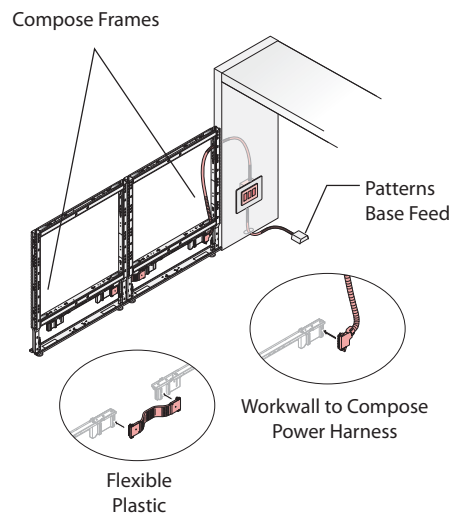

Top Feed Modules

Top Feeds are used to transition building wiring located in the ceiling to modular power within the furniture. One end is hardwired to a junction box and the modular end snaps into the power distribution assembly (PDA) in the panel. Top Feeds with poles are used to span between ceiling and panels and are available with or without power harness for 10' or 12' ceiling heights.

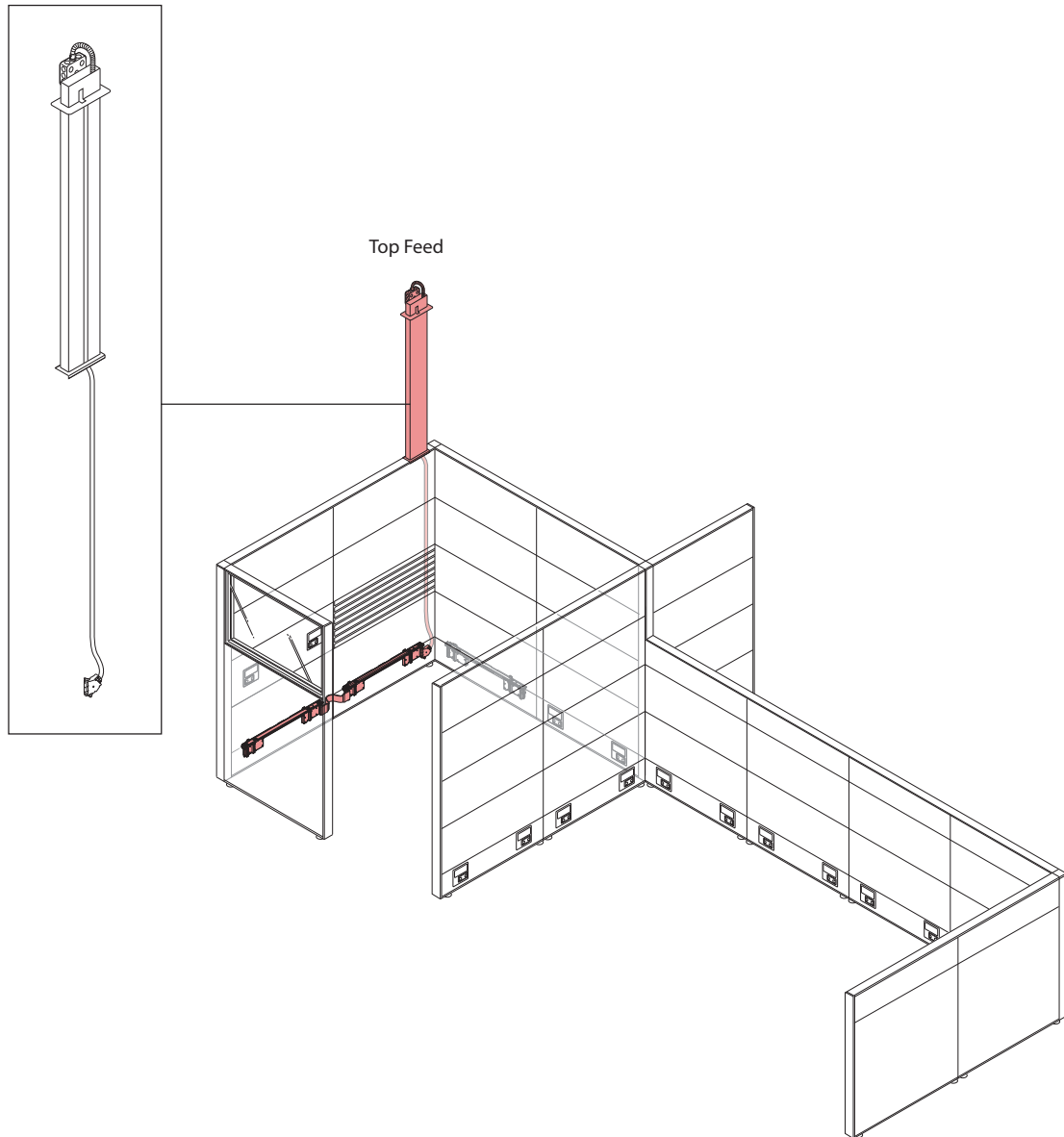

Note Refer to cable management section for more information about communication cable specification and planning.

Top Feed Module

Top Feed

The module mounts to a panel frame and routes power and communications cabling from the ceiling to the base raceway or work height.

Specification Tips

- For use with 24"– 60" (610mm–1524mm) wide powered panels.
- Not for use with glass panel or glass stack.
- Mounts at the end of the panel frame.
- May be used when routing power from Compose into Enclose or Patterns.
- Specify Architectural Power on the Compose Panels used to route power into Enclose or Patterns.
- Wire harness length is 180" (4572mm) regardless of pole length.

Power Location

- 10' and 12' Ceilings

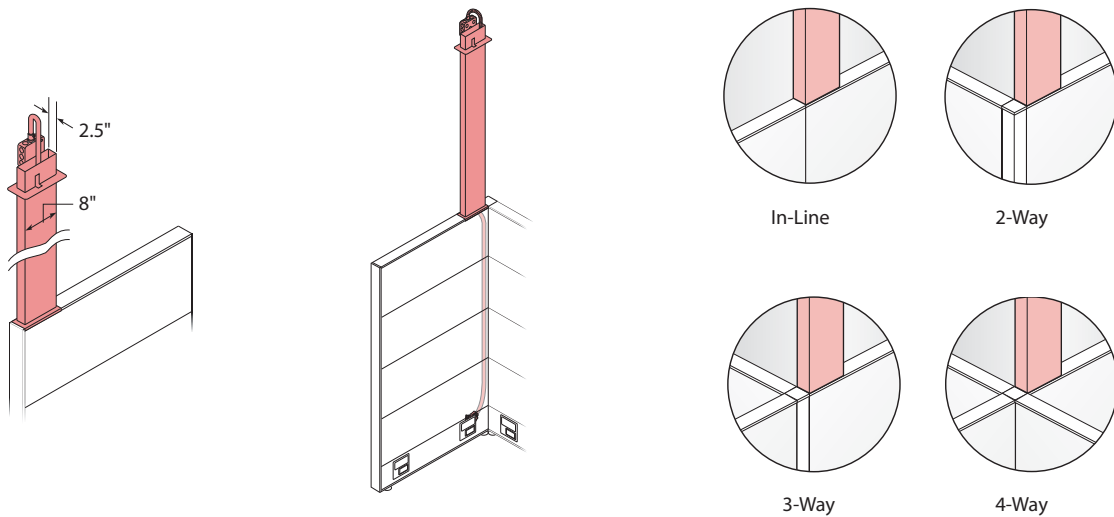

Infeed Harness

The harness is used to transition building wiring to modular power within the furniture. One end is hardwired to the building wiring and the modular end snaps into the power distribution assembly (PDA) in the furniture. This connection may be used to bring power in from the base or ceiling.

Specification Tips

- For use with 24"– 60" (610mm–1524mm) wide powered panels.
- Not for use with glass panel or glass stack.
- May be used when routing power from Compose into Enclose or Patterns.
- Specify Architectural Power on the Compose Panels used to route power into Enclose or Patterns.
- Wire harness length is 180" (4572mm).

Power Location

- Floor
- Column
- Wall
- Ceiling

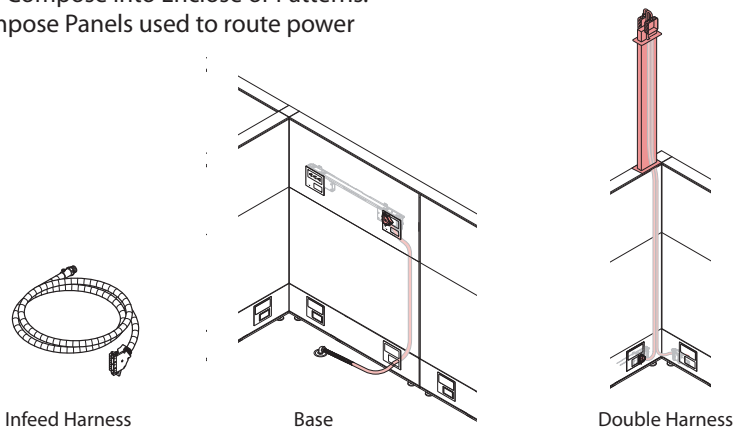

Powered Frame

Base Power

Powered panel frames simplify planning power for a workstation. A powered panel frame includes a power distribution assembly (PDA) and a flex connector. The PDA is used to connect all other electrical components. The PDA mounts to 24"–60" (610mm–1524mm) panel frames. The PDA has two connector ports at each end and two receptacle ports at each end. The connector ports on a PDA provides for the connection of flex connectors, top feeds and vertical power connectors. The receptacle port is used for receptacles and base feeds.

Specification Tips

- For use with 24"–60" (610mm–1524mm) wide panel frames.
- Order extended power connector to pass power through an 18" (457mm) wide panel frame.
- Order straight span connector for non-powered 3-Way or 4-Way conditions.
- Retrofit kits available to convert a non-powered panel frame to a powered panel frame.
- Receptacle and data blank covers must be separately specified.

Power Distribution Assembly

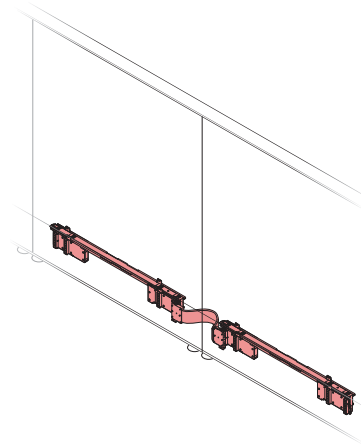
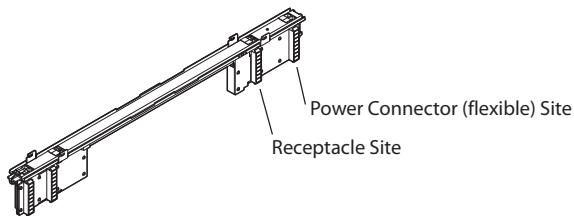

Flexible Connector

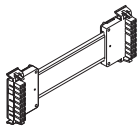

Base Raceway Covers: Receptacle and Data Blank Covers

Raceway covers with power and data access do not include receptacle or data blank covers. Raceway covers with unused openings require a separately specified blank cover to conceal each opening.

Base Raceway Cover



24" (610mm) Panel



30" – 60" (762mm – 1524mm) Panel

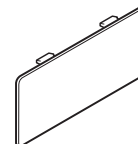
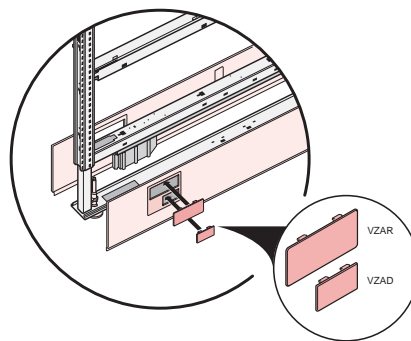

Receptacle Blank Cover
(specified separately)



Data Blank Cover
(specified separately)

Note Base cover dimensions are located in the Cable Management Section.

Power Kits

Work Height Compose allows power to be accessed at three work height locations: Below Worksurface, Beltline, and at Standing Height using retrofit kits. Beltline power can also be specified when ordering the panel frame. The power retrofit kits include a power distribution assembly (PDA), cross bar bracket, and an aligner light block. Beltline kits also include a flex connector for horizontal power routing to adjacent panels. Power at the below worksurface level can be routed horizontally to adjacent panel frames using a Power Connector for Below Worksurface. Power at the standing height cannot run horizontally and requires power to be brought up from the base using a Vertical Power Connector on each panel. The Vertical Power Connector is used with Below Worksurface and Beltline power. To access power with a receptacle in the PDA at work height levels, specify a technology tile or Power and Communication Bezel kit (field installed) on a fabric tile.

Specification Tips

- For use with 24" – 60" (610mm – 1524mm) wide panel frames.
- No power pass-through for 18" (457mm) wide panel frames. Power must be routed to the base to bypass and 18" (457mm) wide panel frame.
- Not for use with 8" (203mm) tiles as they cannot be ported.
- For below worksurface height use Below Worksurface power connector or vertical power connector.
- Beltline requires a minimum panel frame height of 42" (1067mm).
- Standing height requires a minimum panel frame height of 58" (1473mm).
- Order straight span connector for non-powered 3-Way or 4-Way conditions at Beltline.
- Retrofit kits available to convert a non-powered panel frame to a powered panel frame.
- Power cannot route horizontally at standing height and requires panel frame to be powered at base raceway.

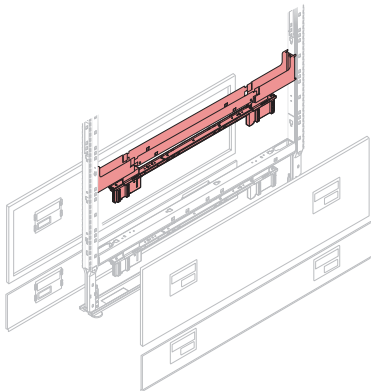

Below Worksurface Height and Standing Height

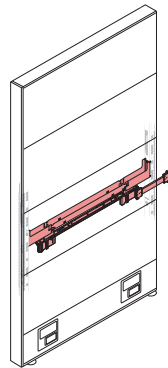

Beltline

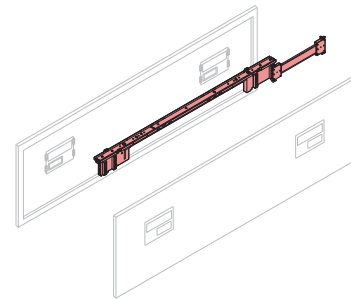

Panels (58" [1473mm] in height)

For standing height power on 58" (1473mm) high frame use beltline power retrofit kit for 42" (1067mm) high panels.

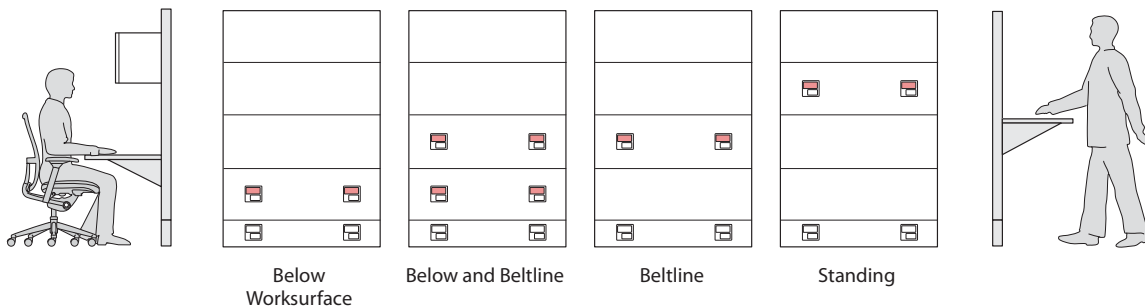

Tile Options



No Power Pass-Through 18" (457mm) Frame



Single Bezel 24" – 60" (610–1524mm) Tile (Left or Right)



Double Bezel 30" – 60" (762–1524mm) Tile

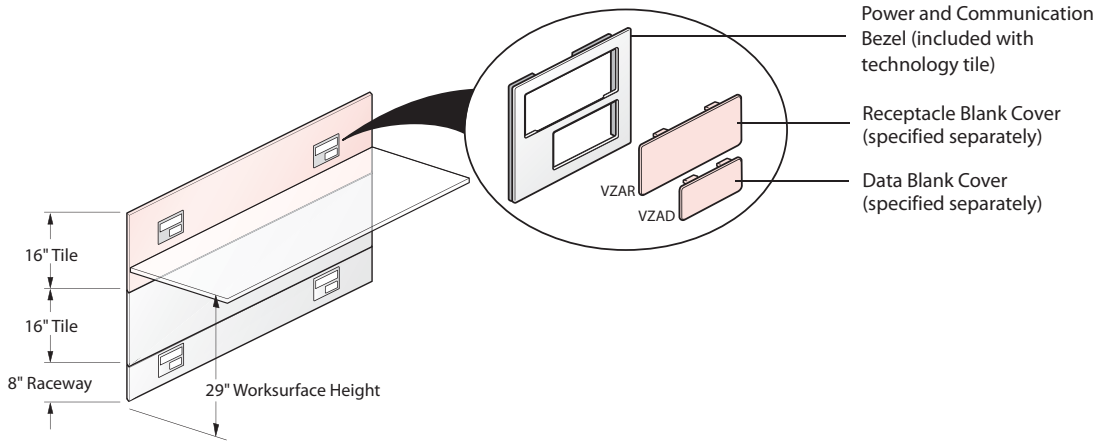

Note Bezel sizes can be found in the Cable Management Section.

18" (457mm) Pass-Through

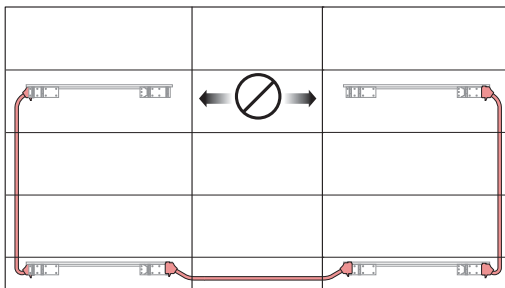

Below Worksurface Connector

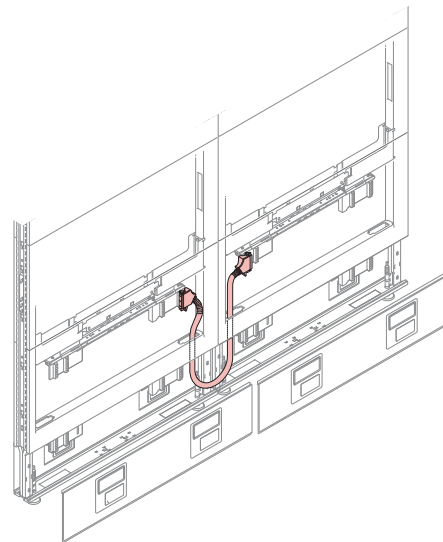

Power Connectors

Flexible Power Connector: Panel-to-Panel

These connectors are used to span power from one powered panel frame to another adjacent powered panel frame. A power distribution assembly (PDA) and flexible connector are provided when a powered panel frame is ordered.

Specification Tips

- May be used in straight panel-to-panel application, inside 90° and inside 120° within the base raceway.
- Base connector is 13¾" (349mm) long and beltline connector is 13" (330mm) long.

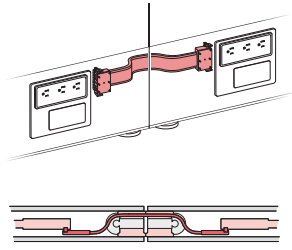
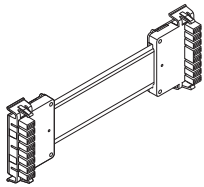

Base Straight Condition (13¾" [349mm])

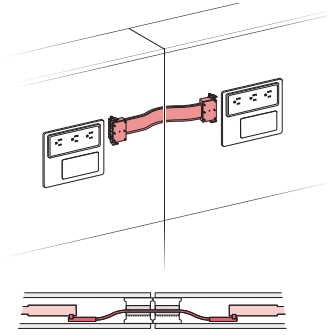

Beltline Straight Condition (13" [330mm])

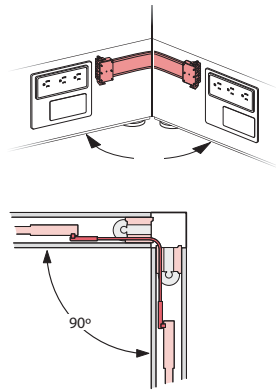

Base Inside 90° Condition (13¾" [349mm])

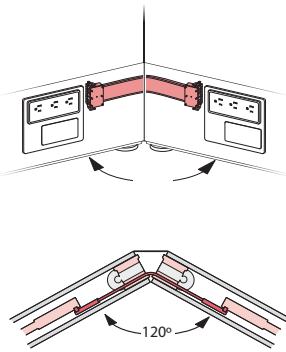

Base Inside 120° Condition (13¾" [349mm])

Flexible Power Connector: Straight Span Raceway/Beltline

The connector is used to span power from one powered panel to another powered panel in an outside 90°, 3-Way, or 4-Way condition when return panels are non-powered. These connectors must be separately specified.

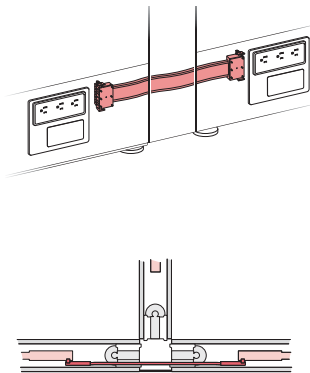
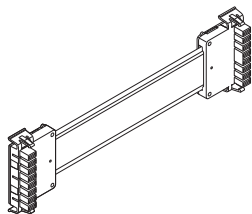

Base Straight Span Condition

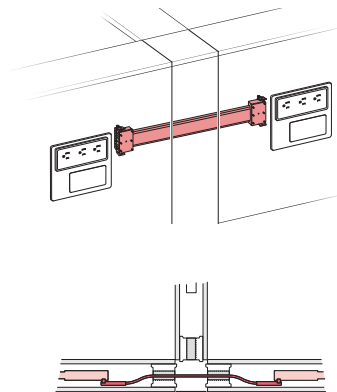

Beltline Straight Span Condition

Power Connectors

Flexible Power Connector: Corner Span Beltline

The connector is used to span power from one panel to another between adjacent powered panels in beltline 90° and 120° conditions. These connectors must be separately specified.

Specification Tips

- For use with beltline power only.

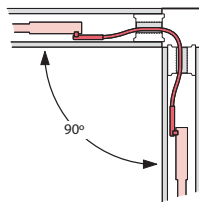
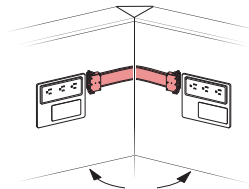
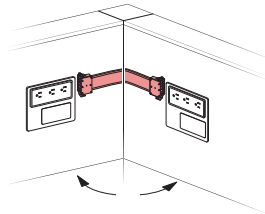
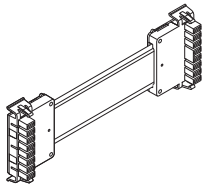

Beltline 90° Condition

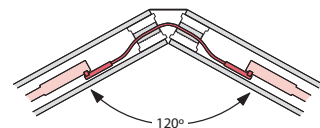

Beltline 120° Condition

Power Connector Below Worksurface

The connector is used to span power horizontally from one panel with below worksurface power to an adjacent panel with below worksurface power. These connectors must be separately specified.

Specification Tips

- For use with below worksurface power kits only.
- Connector spans to adjacent panel in straight, 3-Way span, 4-Way span, 120° corner, or 90° corner configuration.

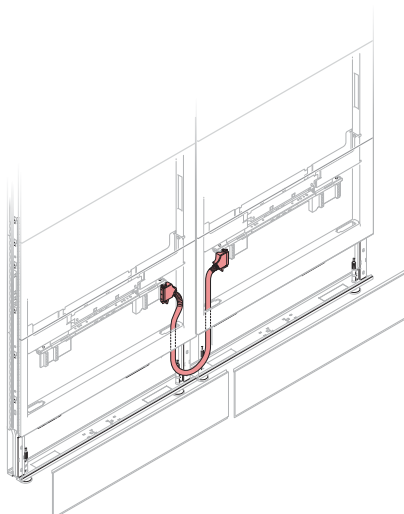

Power Connectors

Extended Power Connectors

The connector is used to pass power through one 18" wide non-powered panel.

Specification Tips

- For use in base raceway only.
- Not for use with hard surface tiles to the floor.
- Connectors cannot be coupled together.
- One length for straight, 90° corner, 3-Way span, 4-Way span, and 120° corner conditions.

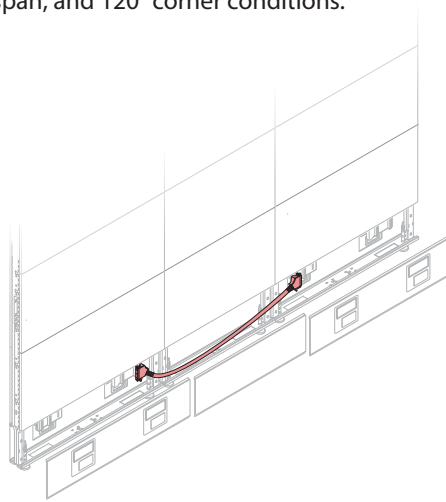
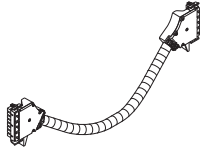

Vertical Power Connector

These connectors route power vertically from the base to work height levels.

Specification Tips

- Cannot be used with glass panel or glass stack.

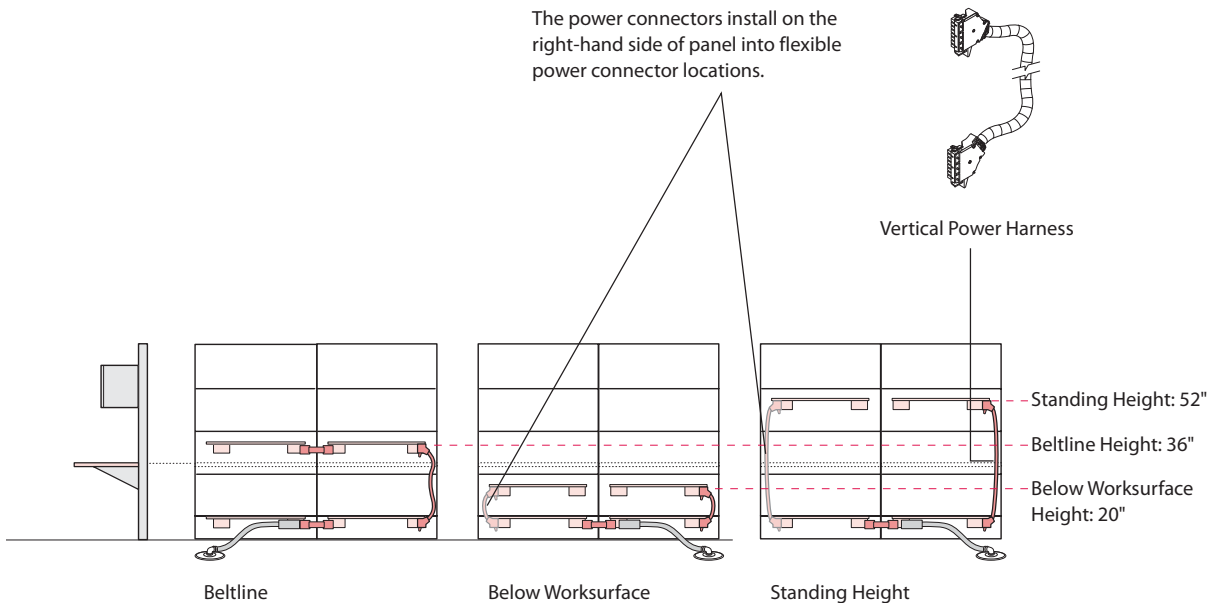

Note Installed height measures from the bottom of the raceway pan to center of receptacle.

Receptacles

Receptacles

Receptacles attach to the power distribution assembly (PDA) to allow access to the circuits carried through a panel. The 3-Circuit 15 Amp receptacles have a circuit programmable feature that allows each receptacle to access either circuit 1, 2, or 3 in the field by simply sliding the connector to one of three positions.

Specification Tips

- 15 Amp receptacle configuration is NEMA 5-15R.
- 20 Amp receptacle configuration is NEMA 5-20R.
- 3-Circuit 20 Amp and 4-Circuit receptacles have fixed circuit access and are not field programmable. Specify appropriate number of receptacles for each circuit.
- Specify common ground or isolated ground.

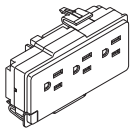

15 Amp

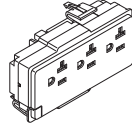

20 Amp

POWER CONFIGURATION	RECEPTACLE IDENTIFIER			
2+2	1	2	3	4
3+1	A	B	C	D
3-Circuit (20 amp)	I	II	III	NA

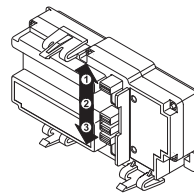

3-Circuit 15 Amp Programmable Receptacle

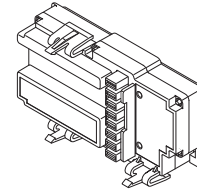

- 3-Circuit 20 Amp
- 4-Circuit 15 Amp
- 4-Circuit 20 Amp

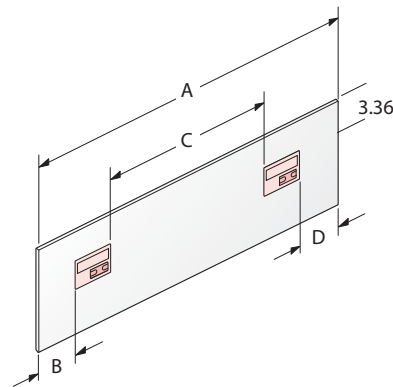
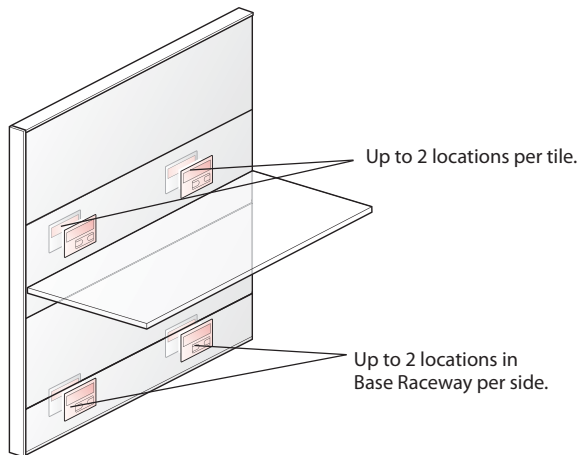

Power and Communications Port Dimensions

TILE WIDTH	A	B	C	D
24"	23.6"	5.75"		
30"	29.6"	5.75"	6.23"	5.64"
36"	35.6"	5.75"	12.23"	5.64"
42"	41.6"	5.75"	18.23"	5.64"
48"	47.6"	5.75"	24.23"	5.64"
60"	59.6"	5.75"	36.23"	5.64"



- If receptacles are not specified, all open locations must be covered using separately specified Receptacle Blank Covers (VZAR-0000).
- Receptacle or Data Blank Covers are separately specified for Technology Access Tiles when technology is not used.

Receptacles

Desktop Port

Desktop ports provide three 15A outlets and a modular furniture telecommunications outlet opening in a housing that can be clamped to the edge of a worksurface.

Specification Tips

- Power cord plugs into a panel or building receptacle outlet.
- Desktop ports cannot be linked (daisy chained) together.
- Cord use should be reviewed by local authorities (electrical inspector) prior to ordering.
- Modular furniture telecommunications faceplate must be field supplied.

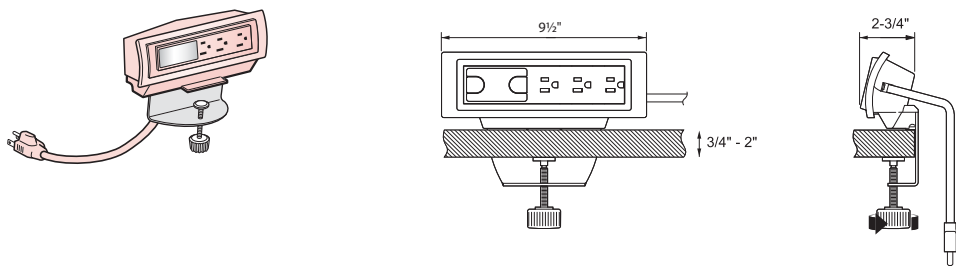

Flip Top Unit

Flip Top Unit provides 15 Amp outlets and data jacks in a desktop housing that flips up for access or can be closed for unobstructed work space.

Specification Tips

- Flip Top Unit must be field installed on worksurfaces by field cutting a hole.
- Hardwired applications should be reviewed by local authorities (electrical inspector) prior to ordering.
- Corded Flip Top Units with four receptacles utilize a fused plug that may block adjacent building receptacle outlet.

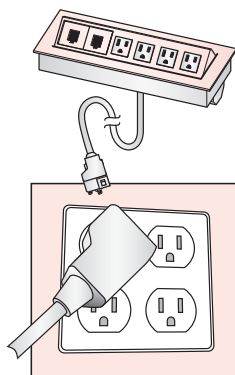
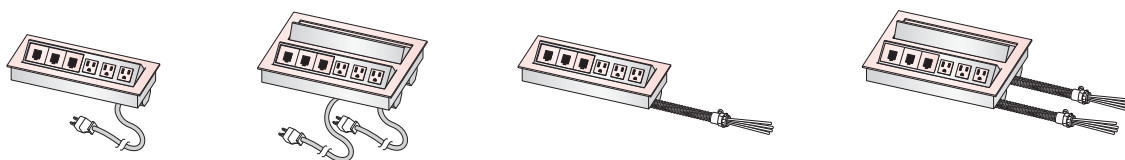

Fused Plug Detail
(for Flip Top Units with four or more outlets)

Flip Top Unit: Details

Flip Top Unit: Side Elevation

- Flip Top Unit: bezel and pop-up portion are proud to worksurface.
- When installed into a 1 $\frac{3}{4}$ " (30mm) worksurface, the Flip Top Unit will extend below the worksurface.

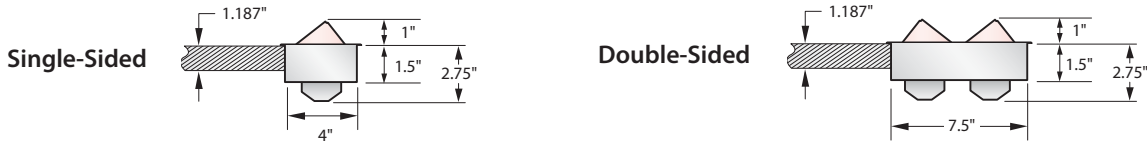

Flip Top Unit Bezel Dimensions:

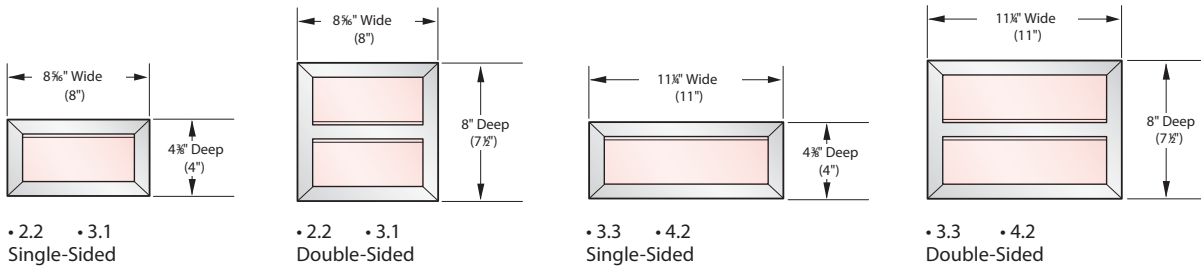

• 2.2 • 3.1
Single-Sided

• 2.2 • 3.1
Double-Sided

• 3.3 • 4.2
Single-Sided

• 3.3 • 4.2
Double-Sided

Note Cutout dimensions are in parentheses ().

The Flip Top Unit includes multiple data jack adapters to accommodate most field supplied data jacks. Also included are blank data covers to be used if no data access is needed. Data jacks are field supplied.

- 15 Amp rated simplex power receptacles
- Data information access ports

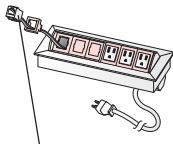

Data jack adapters standard in white; included with Flip Top Unit. (See manufacturer list for field supplied data jacks).

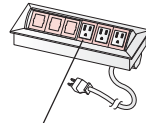

Perimeter edge of power receptacles and data ports faceplate standard in white.

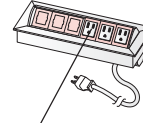

Simplex power receptacles standard in white; included with Flip Top Unit.

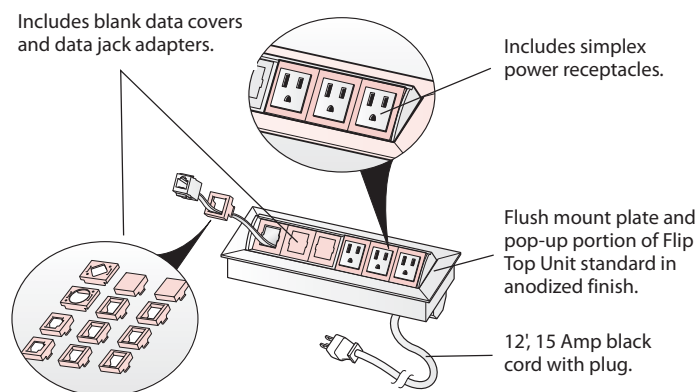

Data Jack Adapters Included

Manufacturer's List of Field Supplied Data Jacks

Systemax/CommScope
Tyco SL and 110 Connect Series Modular Jacks
Siemon Keystone Style
Allen Tel Versa Tap Series
Leviton Quick Port® Series
Nordx Keystone Style
Tyco SL Coupler Series
ADC (Krone) 6000 Series
Hubbell Xcelerator™ Keystone Series
Blank (no coupler/jack)
Ortonics TracJack Series
Panduit Mini-Com Series
Microphone Jack/3-Pin XLR (solder type only)
Video Monitor Jack/DB-15 (panel mount solder style)

Power Basics

3-Circuit

- As many as three separate 20-Amp rated circuits from one power feed module.
- 8-Wire system enclosed in one power distribution assembly:
 - 3 hot wires
 - 3 neutral wires
 - 1 common ground wire
 - 1 isolated ground wire
- Separate neutrals, one dedicated to each circuit, are capable of carrying computer-quality power.

4-Circuit

- As many as four 20-Amp rated circuits from one power feed module.
- 8-Wire system enclosed in one power distribution assembly:
 - 4 hot wires
 - 2 neutral wires
 - 1 common ground wire
 - 1 isolated ground wire
- 4-Circuit product is available in either a 2+2 configuration or a 3+1 configuration. Both configurations utilize a shared neutral conductor for at least two circuits. All circuits have access to either common or isolated ground.

Hardwire

- Components available to meet Chicago and other similar hardwire configurations.
- Consists of infeeds, junction boxes, and mounting hardware.
- Field supplied wire and receptacles allow for a variety of applications for specific needs.

Panel Power Options:

- 3-Circuit and 4-Circuit: Panel options specified with 3- or 4-Circuit power include a power distribution assembly and a flex connector.
- New York City (NYC): The New York City option includes the same components as those listed above but are shipped separate from the panel and require field installation.
- New York Port Authority (NYPA): The New York Port Authority option includes a metal raceway cover and is available with or without the power components.
- Hardwire: The hardwire option includes raceway covers for receptacle access. Hardwire electrical raceway kits and receptacle covers must be separately specified. In addition, receptacles, conduit, wiring, and other associated components must be field supplied.

3- and 4-Circuit Overview

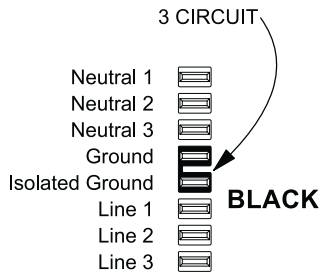

3-Circuit/Separate Neutrals

This option provides three circuits, each with its own neutral.

- Aligns with the 3 phase national power grid and most North American buildings.
- Is compatible with the following building power configurations:
 - 3 phase (208Y/120V)
 - Three wire single phase (120/240V)
 - Single phase (120V)
- Offers the most adaptability to special power needs such as:
 - multiple power sources
 - facility energy control
 - isolation of high harmonic loading
- Features receptacles with patented on-site circuit access programmability (available only on Power Base for furniture).
- Offers receptacles in common ground or isolated ground configurations.

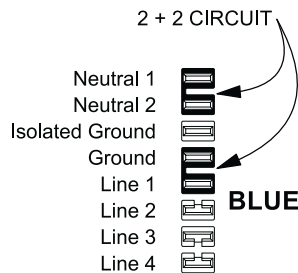

4-Circuit/2+2

This option provides four circuits, two circuits share neutral #1, two circuits share neutral #2.

- Provides more circuits (4 vs. 3) for each homerun from the electrical closet, which can reduce the installed cost per circuit.
- Is compatible with the following building power configurations:
 - 3 phase (208Y/120V)
 - Three wire single phase (120/240V)
- Is sometimes less adaptable to special power needs such as multiple power source or facility energy control.
 - Special power needs are typically planned in sets of two circuits
 - In some cases, 10 gauge shared neutral may not fully isolate circuits
- Modular receptacles have fixed circuit access.
- Offers receptacles in common ground or isolated ground configurations.

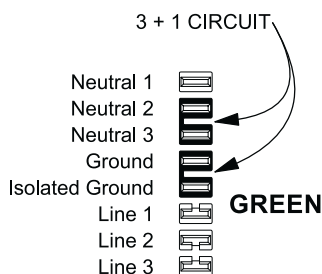

4-Circuit/3+1

This option provides four circuits, three circuits share neutral #1, circuit #4 has a separate neutral.

- Provides more circuits (4 vs. 3) for each homerun from the electrical closet, which can reduce the installed cost per circuit.
- Is compatible with the following building power configurations:
 - 3 phase (208Y/120V)
- Is sometimes less adaptable to special power needs such as multiple power source or facility energy control.
 - Special power needs are typically planned only using circuit #4
 - In some cases, 10 gauge shared neutral may not fully isolate circuits
- Modular receptacles have fixed circuit access.
- Offers receptacles in common ground or isolated ground configurations.

Power Planning General Guidelines and Checklist

All power application information is found in the corresponding component Price List, system-specific specification guide, and Power Base Planning Guide.

Verify the Following:

In: Routing power from the building into the furniture.

- Power feed length will reach building location.
- Infeed fits panel width.
- Infeed location is not occupied by a:
 - Receptacle
 - Horizontal Connector
 - Vertical Connector
- Power raceway cover for external infeed location.

Through: Routing power through the furniture.

- Power Distribution Assemblies (PDAs) are located where power access is needed.
 - Base and/or beltline power is specified.
 - Standing and below worksurface height power are specified with non-beltline retrofit kit.
- Horizontal Power Routing:**
 - Base Power
 - Spanning connectors are specified for each 3-Way/4-Way.
 - Extended power connector for each 18" (457mm) panel.
 - All adjacent panels have base power, 18" (457mm) power connectors cannot be coupled together.
 - Work Height Power
 - Beltline Power
 - Spanning connector for each 3-Way/4-Way connection where return panels are non-powered.
 - Power is only routed through panels 24" (610mm) wide or greater.
 - Below Worksurface Power
 - Power Connector Below Worksurface is specified for routing power to next panel.
 - Power is only routed through panels 24" (610mm) wide or greater.
- Vertical Power Routing**
 - Correct Vertical Power Connector length is specified for work height application.
 - Base power and Vertical Connector are specified in all frames with standing height power application.
 - No more than two Vertical Power Connectors per frame.

Out: Getting power out of the furniture so it can be used.

- Maximum receptacle quantity per feed is not exceeded (13 United States/10 Canada)
 - Fixed circuit receptacles are specified for all circuits.
- Ability to access power through base raceway cover or technology tile.
- Receptacle and data blank covers are specified for each unoccupied bezel opening.

General Power Application Guidelines:

- Power break markers are indicated where needed.
- Panel hung components or floor supported storage do not block receptacle access.
- Do not mix 3-Circuit and 6-Circuit with 4-Circuit components.
- Do not mix 2+2 and 3+1 components.
- Components have unique polarity key and color coding (3-Circuit = black, 6-Circuit = ivory, 2+2 = blue, and 3+1 = green).

Power Distribution for Hardwire Applications

Hardwire power applications are designed to address non-modular power planning solutions.

1. Power distribution from building-to-panel.
2. Vertical power distribution.
3. Horizontal power distribution.

Infeeds	Applications
1 Base Feed	48" (1219mm) or as required
2 Top Feed	Ceiling Height (H) + 18" (457mm)

Panel Applications	Panel Applications
3 Between two junction boxes on one panel	Panel Width (W) – 21" (533mm)
4 Between junction boxes if one per panel	Panel Width (W) – 5" (127mm)
5 Across panel connection	12" (305mm)
6 Across 3- or 4-Way connection	16" (406mm)
7 Base to Beltline	40" (1016mm)
8 Base to under worksurface	24" (610mm)
9 Base to standing height	56" (1422mm)

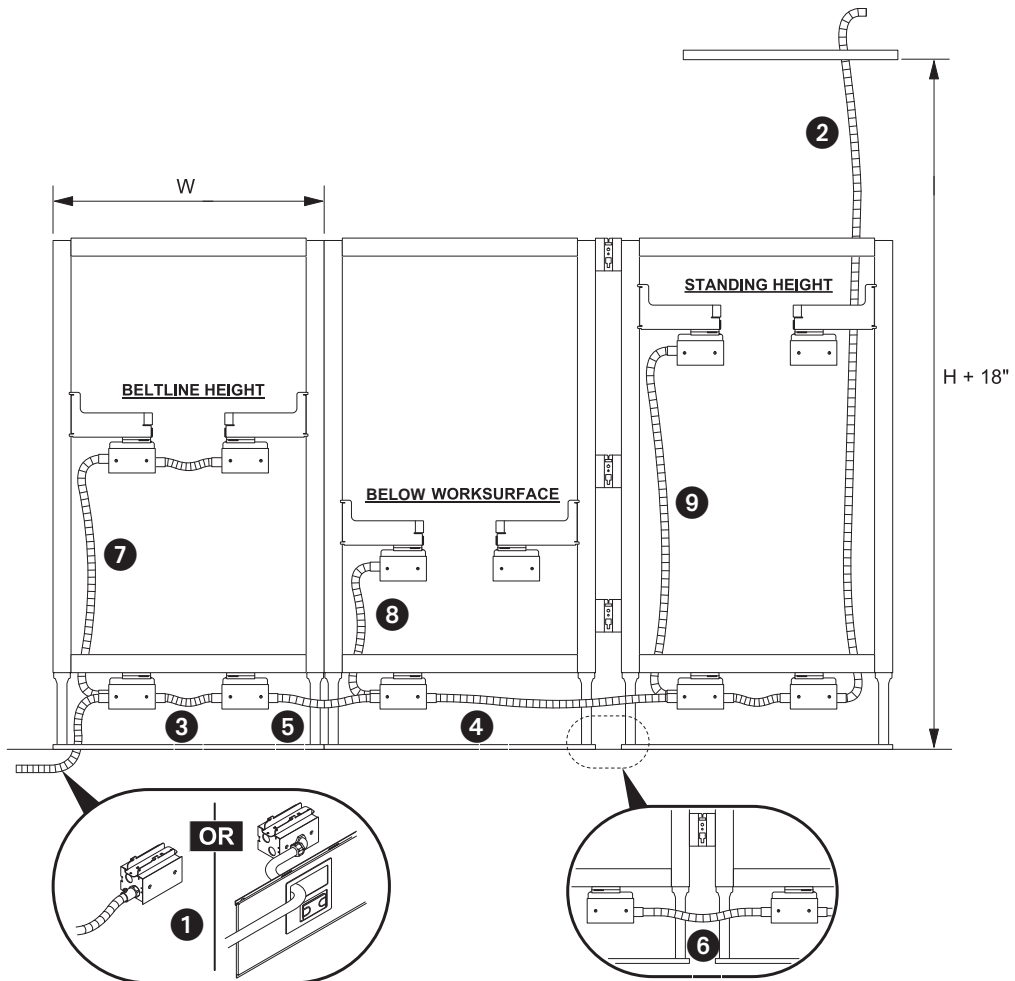

International Power Management

International Power Planning

For power applications outside North America, we recommend the use of Power Logic soft wiring components. Power Logic offers a system of single circuit power cords and receptacle modules that fit into our non-powered Base Raceway. Receptacle Modules are offered with two sockets (three and four socket versions also available). Each Receptacle Module has sockets, switches, and fuses that are appropriate for each country around the world.

- Use a Power Entry Cord to bring power into the Panel's Base Raceway and feed a Receptacle Module mounted to the Base Raceway Cover.
- Use additional Cords to route power to additional receptacles as needed.
- Use a Splitter to branch out in multiple directions (up to four).

Contact the Power Logic regional sales office in your area to help with planning details to assure local electrical code compliance. Contact Power Logic through their website, www.powerlogic.net, or through their corporate offices in Cape Town, South Africa at 27-21-704-1450. Power Logic also offers power solutions for desk top, conference table, or freestanding power applications.

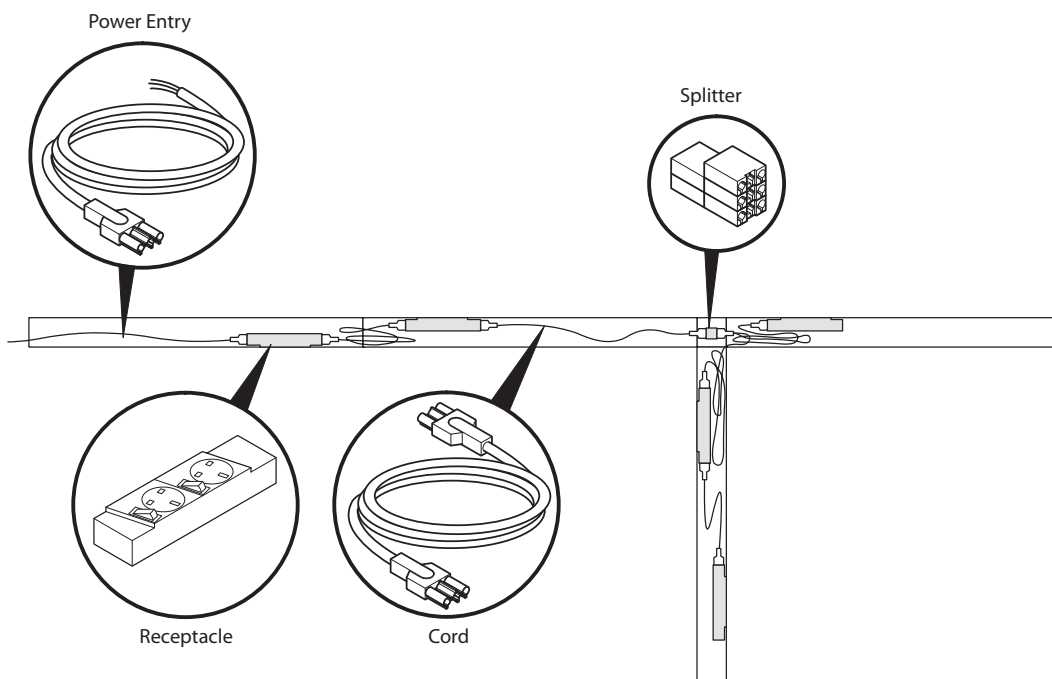

Cable Management: Introduction

Cable Management

Compose addresses the distribution of communications cables with panel-integrated cable pathways and access points.

Cables can be routed through these pathways:

- Panel base pathway
- Beltline horizontal pathway
- Vertical pathway (left side and right side of panel)
- Top Feed module channel

Cables can be accessed at these locations:

- Two Base Raceway communication ports
- One or two Beltline, Below Worksurface, or Standing Heights communication ports

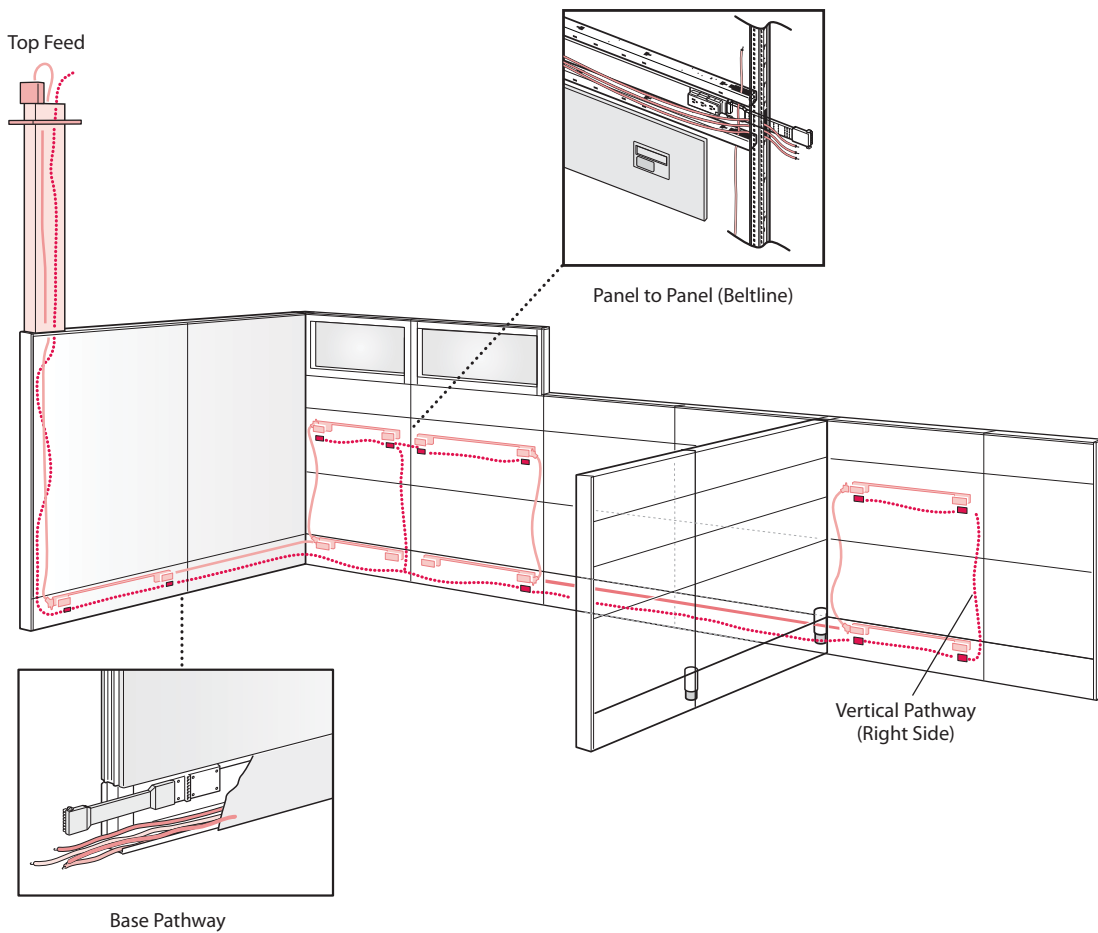

Cable Management: Introduction

Cable Bend Radius

When planning the routing of communications cables through panels, the bend radius at the panel-to-panel connections and within the panel pathways should be taken into consideration.

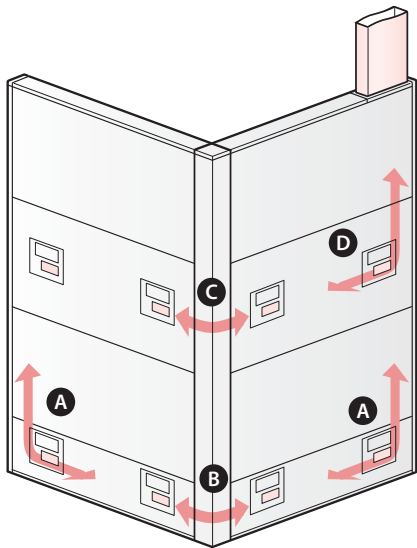

A

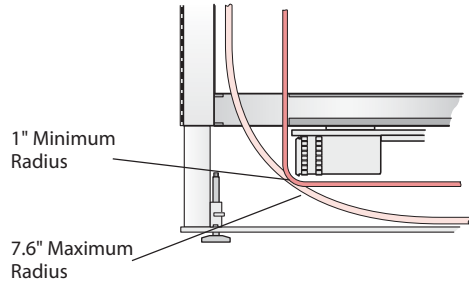

B

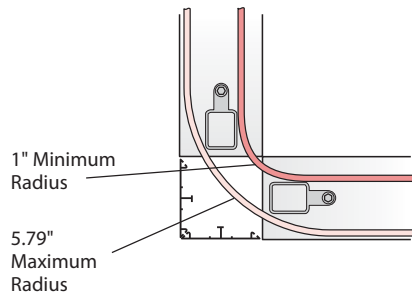

C

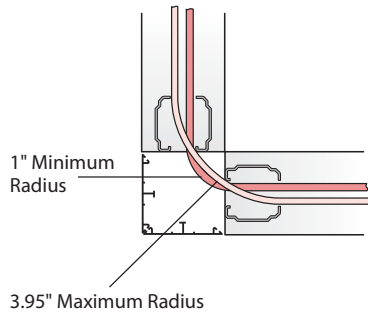

D

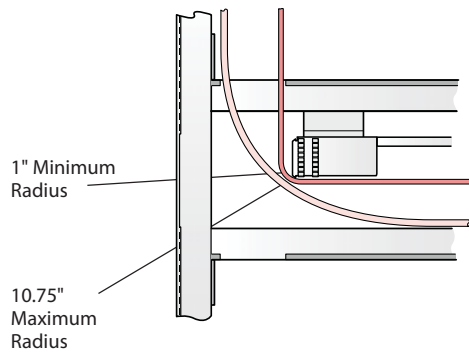

Base Raceway: Communication Options and Dimensions

Base Raceway with Single Gang Opening

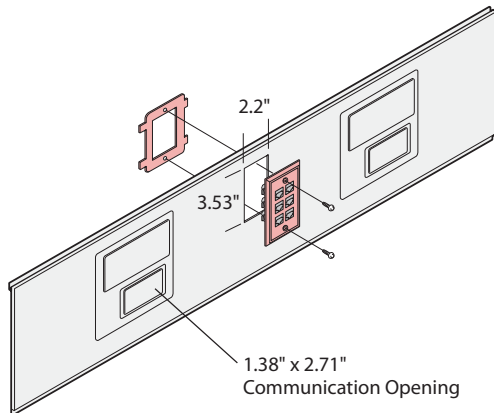

PANEL WIDTH	"A" MEASUREMENT
30" (762mm)	12.86" (327mm)
36" (914mm)	15.86" (403mm)
42" (1067mm)	18.86" (479mm)
48" (1219mm)	21.86" (555mm)
54" (1372mm)	24.86" (631mm)
60" (1524mm)	27.86" (708mm)

Technology Access Tile Opening

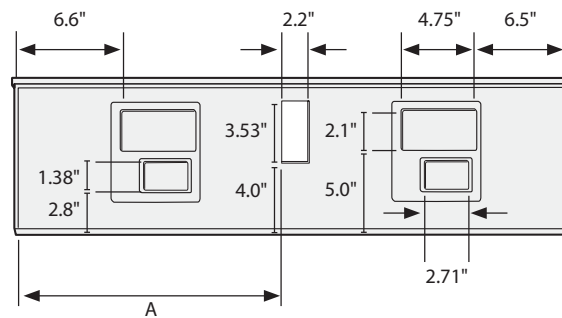
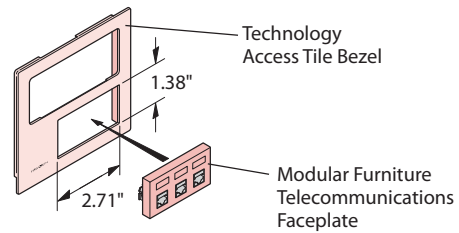

The following manufacturers offer faceplates that fit modular furniture telecommunications openings. For additional details, contact your local Haworth Technical Representative.

- Systemax/CommScope
- Tyco
- Siemon
- Leviton
- ADC
- Hubbell
- Belden
- Ortonics
- Panduit
- Hubbell

Cable Management

Cable Capacities

This chart shows the number of communication cables that can be routed through specific pathways. Cable capacities are based on 0.20" (5mm), 0.28" (7mm), and 0.30" (8mm) diameter cables at 60% and 40% fill capacity. TIA/EIA 569A suggests a cable fill of 40% for planning and up to 60% for unplanned or future additions.

Compose Pathway Capacities	Cable Pathway Area		Cable Capacity					
	AREA		60% FILL			40% FILL		
	SQ. IN	SQ. MM	0.20" (5MM)	0.28" (7MM)	0.30" (8MM)	0.20" (5MM)	0.28" (7MM)	0.30" (8MM)
Example								
One square inch pathway	1	645	19	10	8	13	6	6
Horizontal pathways								
Base pathway, powered ¹	5.2	3335	99	51	44	66	34	29
Base pathway, powered, tiles to floor	2.6	1677	50	25	22	33	17	15
Base pathway, non-powered ¹	5.2	3335	99	51	44	66	34	29
Base pathway, non powered, tiles to floor	2.6	1677	50	25	22	33	17	15
Beltline pathways								
Beltline pathway, powered	3.2	2065	61	31	27	41	21	18
Beltline pathway, non-powered	5.2	3335	99	51	44	66	34	29
Vertical pathways (2 per panel)								
With 3-Circuit power ²	3.5	2258	67	34	30	45	23	20
Without power harness	3.9	2516	75	38	33	50	25	22

Notes

- ¹ When using cable management bracket.
- ² When routing 3-Circuit and 4-Circuit Top Feed power harness or Beltline power connector.

This page intentionally left blank.

Power and Communication: Introduction

The UniGroup Too system accommodates all power and cable management needs through the Power Base electrical distribution system and multiple cable pathways. Power Base is a modular electrical system available in the base raceway and beltline. Power Base is offered in 3-Circuit and 4-Circuit (2+2 or 3+1) configurations. Power Base components are designed to address three functions:

1. **In:** Routing power from the building into the furniture.
2. **Through:** Routing power through the furniture.
3. **Out:** Receptacle access at panel.

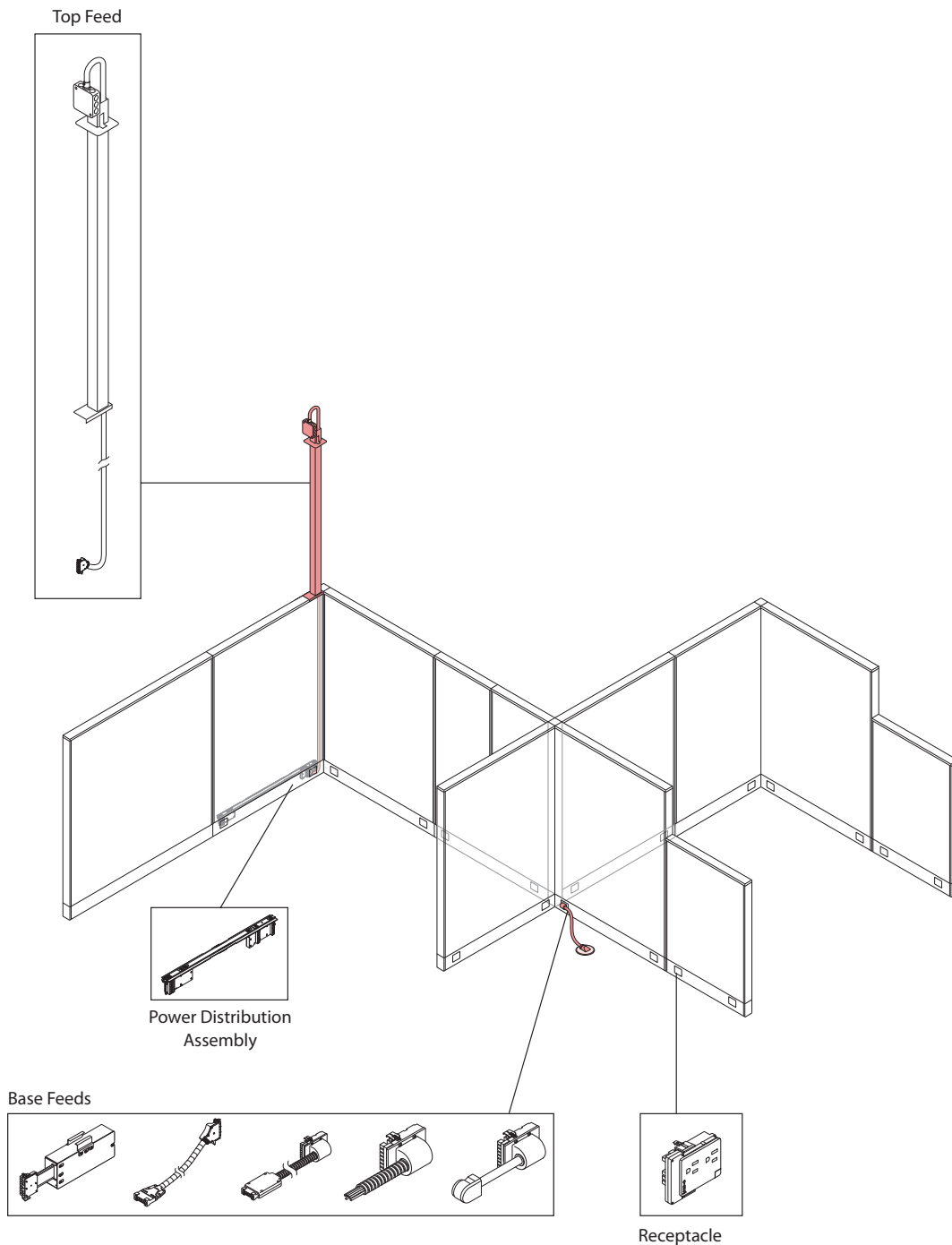

Power Statement of Line

In: Building to Panel

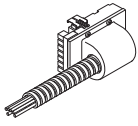

Base Feed Module:
Hardwire Connection

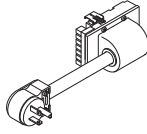

Single Circuit Base Feed Module:
Receptacle Connection with Power Cord

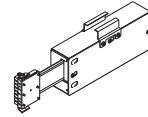

Base Feed Module: Concealed
Hardwire Connection

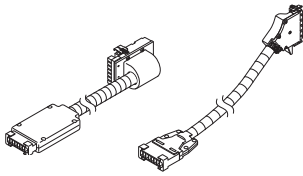

Power Base All Feeds

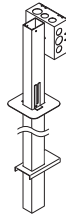

Top Feed

Through: Power Distribution

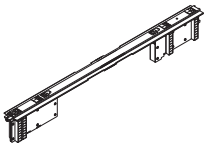

Power Distribution Assembly

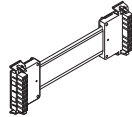

Flexible Power Connector

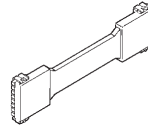

12" Pass-Through

Out: Receptacle Access

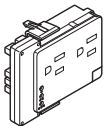

15 Amp Receptacle

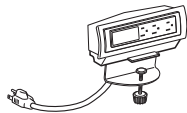

Desktop Port

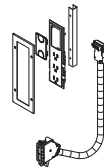

Port Kit

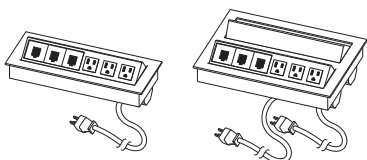

Flip Top Unit

Base Feed Modules

Base Feed Module: Hardwire Connection

The module is used to transition from building wiring to modular power within the furniture. One end is hardwired to the building wiring and the modular end snaps into the power distribution assembly (PDA) in the furniture.

Specification Tips

- For use with 18"–60" (457mm–1524mm) wide powered panels.

Power Location

- Floor
- Column
- Wall

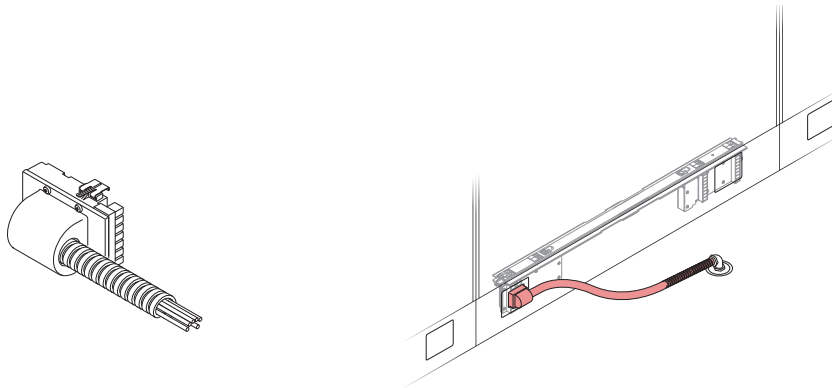

Single Circuit Base Feed Module: Receptacle Connection with Power Cord

The module is used to transition from building wiring to modular power within the base of the furniture. The cord end is plugged into a receptacle (NEMA 5-20R USA/NEMA 5-15R Canada) in the building and the modular end snaps into the power distribution assembly (PDA) in the furniture. Only circuit one is powered by a cord feed. This feed is used for small furniture clusters such as a reception desk. National codes restrict the length of the cord; 24" (610mm) in the United States, 72" (1829mm) in Canada.

Specification Tips

- For use with 18"–60" (457mm–1524mm) wide powered panels.
- Not for use with isolated ground receptacles.

Power Location

- Floor
- Column
- Wall

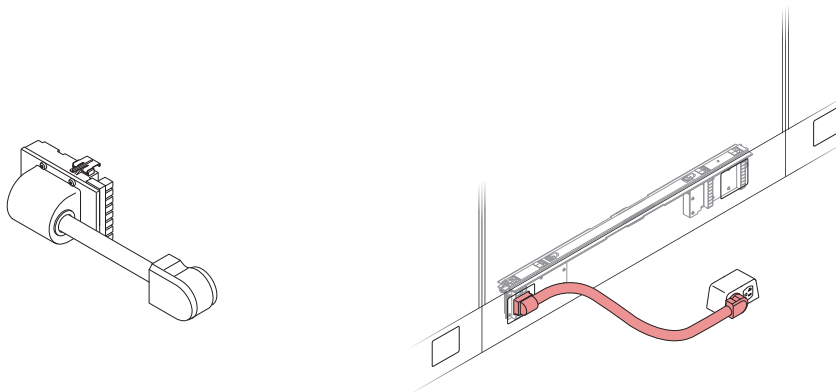

Base Feed Modules

Base Feed Module: Concealed Hardwire Connection

The module is used to transition building wiring to modular power within the furniture. The module's junction box is mounted to the furniture and its modular connector snaps into the power distribution assembly (PDA). Field supplied conduit is used to bring power from the building to the junction box allowing for versatile applications. Although used primarily to meet New York City code requirements for a base feed infeed, it is not limited for use in this locale.

Specification Tips

- For use with 30" – 60" (762mm–1524mm) wide powered panels.

Power Locations

- Floor
- Column
- Wall

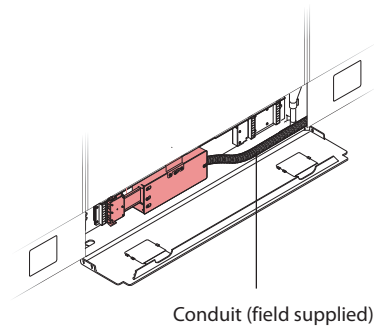
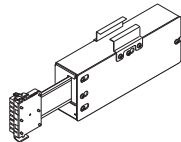

Note New York City code compliant.

Raised Floor Infeed Base Feed Module: External and Internal

These modules are used to make plug-and-play connections between Power Base AI underfloor modular power and Power Base modular power in furniture. Internal version can enter under the panel base so base feed is not visible. The conduit of the external version will be exposed but allows flexibility in positioning furniture.

Specification Tips

- For use with 18"–60" (457mm–1524mm) wide powered panels.
- Can only be connected to Power Base AI underfloor power system.
- Black split tubing may be field supplied to cover any exposed galvanized metal conduit.

Power Location

- Power Base AI



External Base Feed

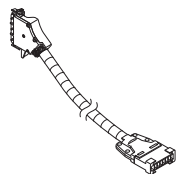
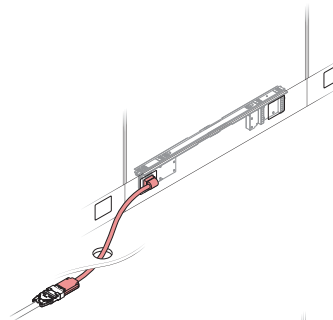

Internal Base Feed

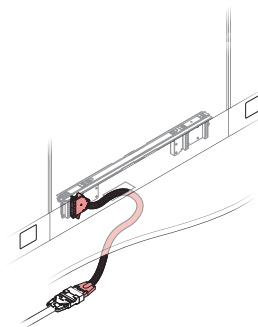

Top Feed Modules

Top Feeds are used to transition building wiring located in the ceiling to modular power within the furniture. One end is hardwired to a junction box and the modular end snaps into the power distribution assembly (PDA) in the panel. Top Feeds are used to span between ceiling and panels and are available with or without power harness for 10' or 12' ceiling heights.

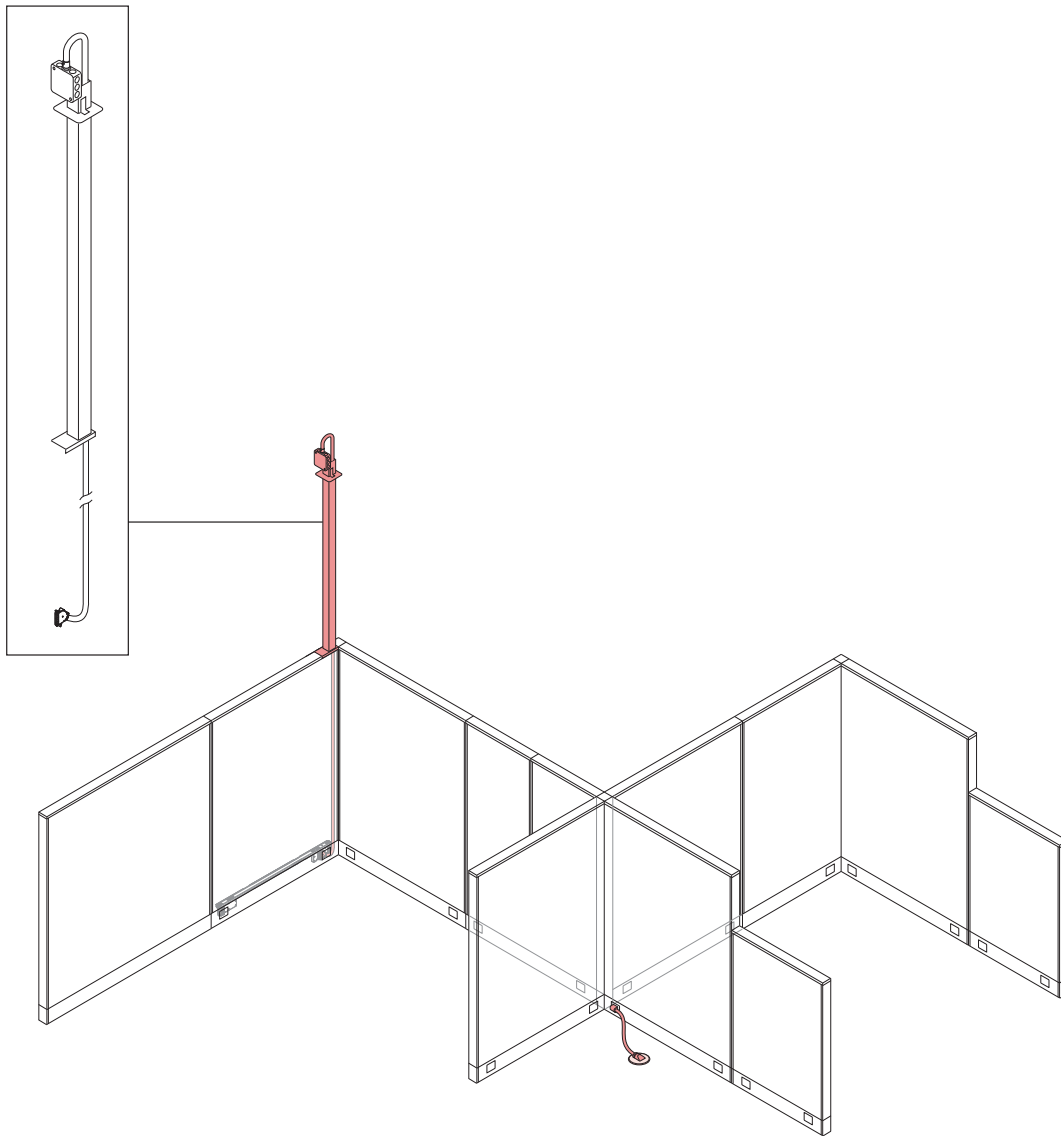

Top Feed Modules

Top Feed

The module mounts to a panel and routes power and communication cabling from the ceiling to the base raceway.

Specification Tips

- For use with 18"–60" (457mm–1524mm) wide powered panels.
- For use with 44"–80" (1118mm–2032mm) high panels.
- Not for use with glazed add-on panels, glazed panels or single doors.
- Mounts at the end of the panel, field cutting of top cap is required.
- Wire harness length is 180" (4572mm) regardless of pole length.
- UniGroup Too, UniGroup and PLACES top feeds are identical with the exception of top cap trim, specify accordingly.

Power Location

- 10' and 12' Ceilings

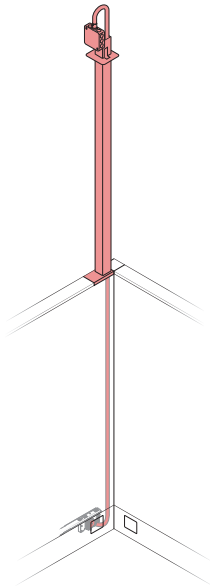

Note Refer to cable management section for more information about communication cable specification and planning.

Powered Panels

Base Power

Powered panels simplify planning power for a workstation. A powered panel includes a power distribution assembly (PDA) and a flex connector. The PDA is used to connect all other electrical components. The PDA has two connector ports and two receptacle ports at each end. The connector ports on the PDA provide for the connection of flex connectors. The receptacle port is used for receptacles, base feeds, and top feeds.

Specification Tips

- For use with 18" – 60" (457mm–1524mm) wide panels.
- 12" (304mm) wide panel use 12" Pass-Through to pass power through.
- Order straight span connector for non-powered 3-Way or 4-Way conditions.
- Retrofit kits available to convert a non-powered panel to powered.
- Receptacle covers are included with powered raceway covers.

Powered Panel

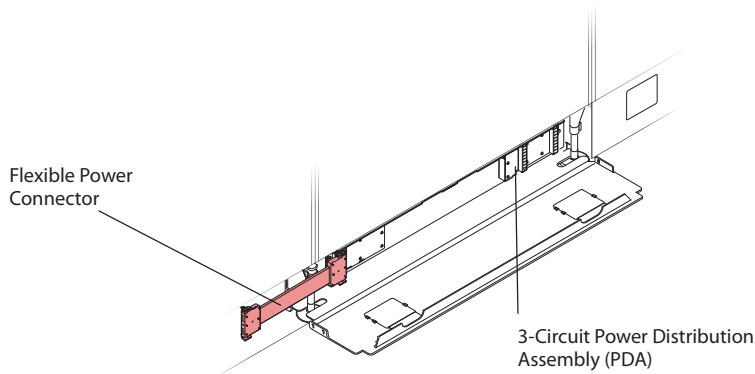

Power Distribution Assembly

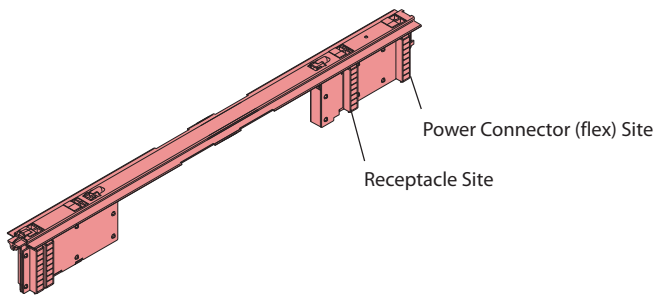

Flex Connector

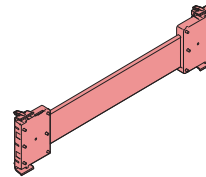

Base Raceway Cover



Note Refer to Haworth's Guide to Cable Management brochure for more information about communication cable specification and planning.

Power Connectors

Flexible Power Connector: Panel-to-Panel

The connector is used to span power from one powered panel to another adjacent powered panel. A power distribution assembly (PDA) and flexible connector are provided when a powered panel is ordered.

Specification Tips

- May be used in straight panel-to-panel or angled conditions within the base raceway.
- Finish post or power connector cover is required by UL for covering flexible power connector at 2-Way and 3-Way conditions.

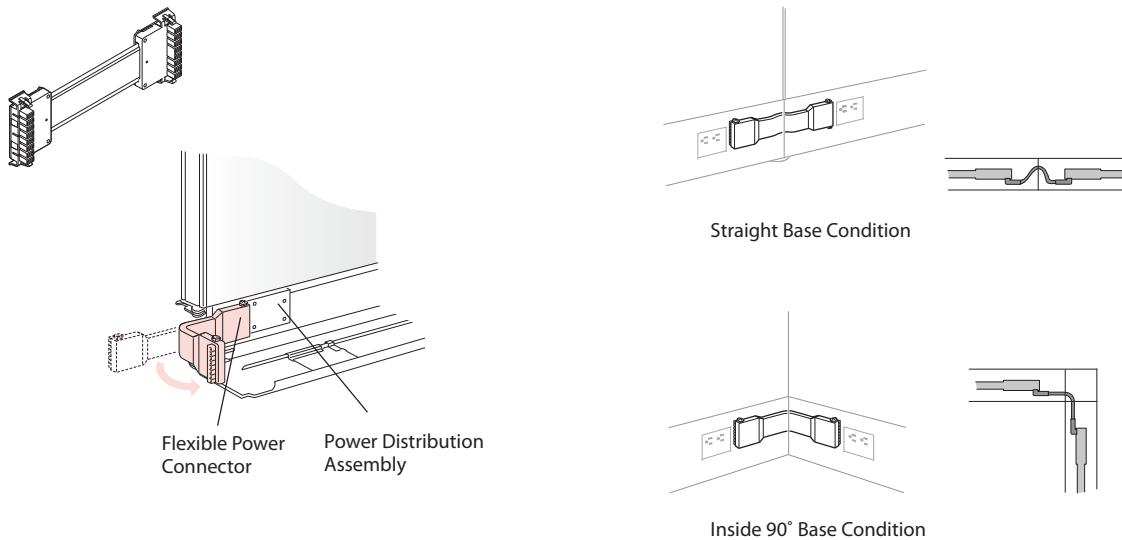

Flexible Power Connector: Straight Span Raceway

The connector is used to span power from one powered panel to another powered panel in an outside 90°, 3-Way, or 4-Way condition when return panels are non-powered. These connectors must be separately specified.

Specification Tips

- Continues electrical circuit across the 2" space between powered panels in a 3-Way, 4-Way, or outside 90° condition in the base raceway.
- Finish post or power connector cover is required by UL for covering straight-span power connector.

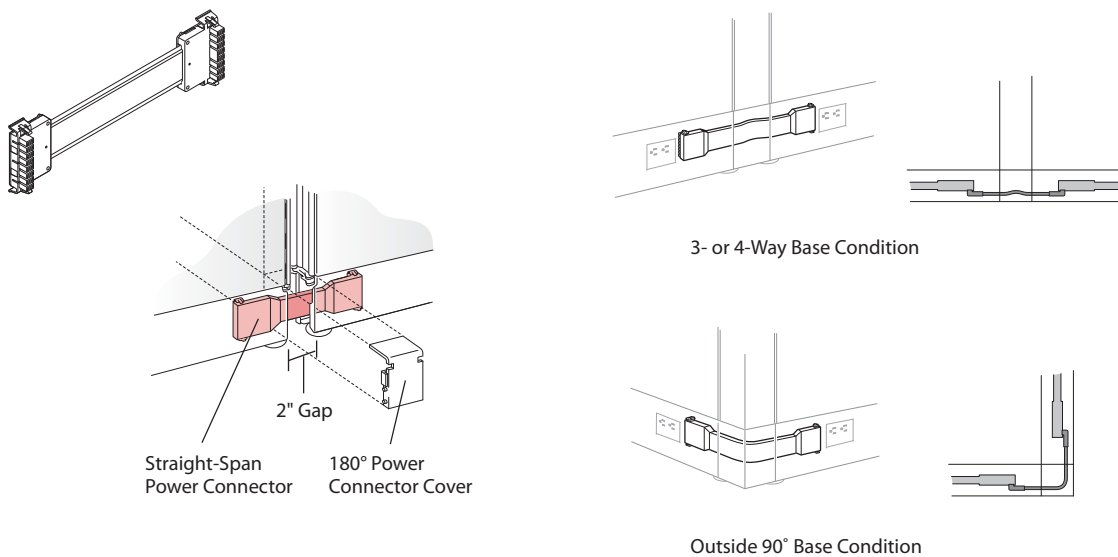

Power Connectors

Flexible Power Connector: Pass-Through

The connector is used to route power through one 12" (305mm) wide non-powered panel.

Specification Tips

- Connector is provided with 12" (305mm) wide powered panel.
- Connectors cannot be coupled together.

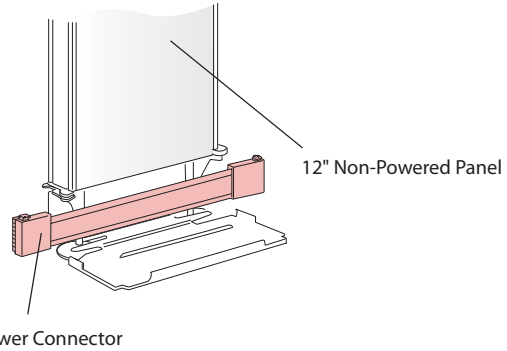
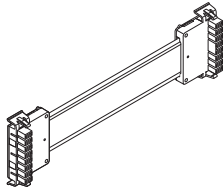

Port Kit Compatibility

Power/Communication Port Kit







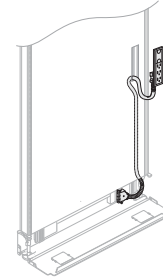

Port kits provide a triplex receptacle at beltline level that flush mounts into the surface of the following UniGroup Too, UniGroup and PLACES panels: basic monolithic, laminate monolithic, monolithic panel with full height inserts, monolithic wood panel, monolithic wood/fabric and high-performance monolithic to provide electrical and/or communication access at beltline.

Specification Tips

- Specification of circuit one, two, three, or four is required.
- Requires field modification of a powered panel.
- Modular furniture telecommunications faceplate must be field supplied.
- Not for use with panels less than 44" (1118mm) high.
- Power/Communication port kit may not be used in back-to-back applications.
- Not for use with monolithic panel with segmented inserts, monolithic panel core without inserts, glazed monolithic, open frame panel and add-on panels.



Port kits work with the following:

Panel Surface Options	UniGroup Too	UniGroup	PLACES
 Fabric: Basic Monolithic	<input checked="" type="checkbox"/>	<input checked="" type="checkbox"/>	<input checked="" type="checkbox"/>
 Laminate: Monolithic	<input checked="" type="checkbox"/>	<input checked="" type="checkbox"/>	NA
 Fabric: Monolithic Panel with Full-Height Inserts	<input checked="" type="checkbox"/>	NA	NA
 Fabric: Monolithic Panel with Segmented Inserts	<input type="checkbox"/>	NA	NA
 Glazed	<input type="checkbox"/>	<input type="checkbox"/>	<input type="checkbox"/>
 Open-Frame	NA	<input type="checkbox"/>	<input type="checkbox"/>
 Wood	NA	NA	<input checked="" type="checkbox"/>
 Panel Inserts (Wood and Glazed)	<input type="checkbox"/>	<input type="checkbox"/>	<input type="checkbox"/>

Receptacles

Receptacle

Receptacles attach to the power distribution assembly (PDA) to allow access to the circuits carried through a powered panel. The 3-Circuit receptacles have a circuit programmable feature that allows each receptacle to access either circuit 1, 2, or 3 in the field by simply sliding the connector to one of three positions. The 4-Circuit receptacles have fixed circuit access and are not field programmable. Specify appropriate number of receptacles for each circuit.

Specification Tips

- 15 Amp receptacle configuration is NEMA 5-15R.
- Specify common ground or isolated ground.

Common Ground

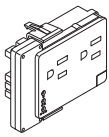

Isolated Ground

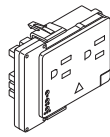

CIRCUIT	CIRCUIT IDENTIFIER			
2+2	1	2	3	4
3+1	A	B	C	D

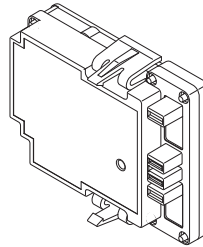

3-Circuit 15 Amp Programmable Receptacle

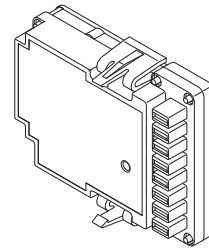

• 3-Circuit 20 Amp
• 4-Circuit 15 Amp

Receptacles

Desktop Port

Desktop ports provide three 15A outlets and a modular furniture telecommunications outlet opening in a housing that can be clamped to the edge of a worksurface.

Specification Tips

- Power cord plugs into a panel or building receptacle outlet.
- Desktop ports cannot be linked (daisy chained) together.
- Cord use should be reviewed by local authorities (electrical inspector) prior to ordering.
- Modular furniture telecommunications faceplate must be field supplied.

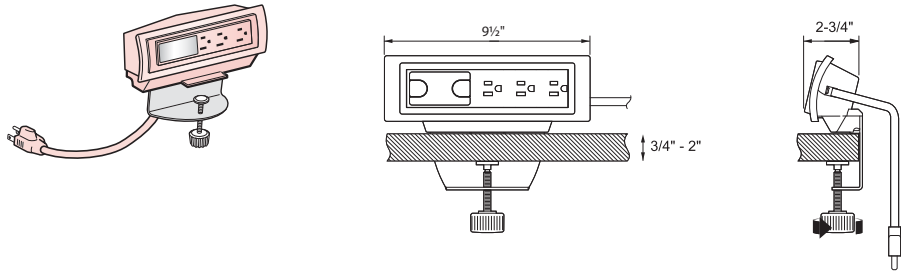

Flip Top Unit

Flip Top Unit provides 15 Amp outlets and data jacks in a desk top housing that flips up for access or can be closed for unobstructed work space.

Specification Tips

- Flip Top Unit must be field installed on worksurfaces by field cutting hole.
- Hardwired applications should be reviewed by local authorities (electrical inspector) prior to ordering.
- Corded Flip Top Units with four receptacles utilize a fused plug that may block adjacent building receptacle outlet.

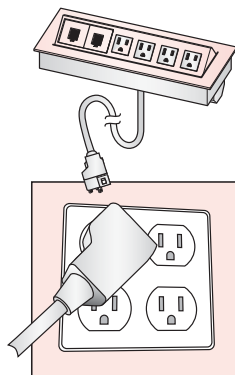
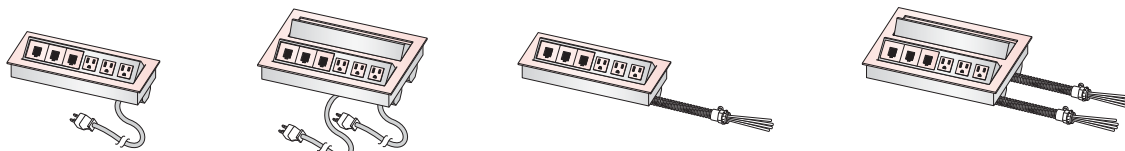

Fused Plug Detail
(for Flip Top Units with four or more outlets)

Flip Top Unit: Details

Flip Top Unit: Side Elevation

- Flip Top Unit: bezel and pop-up portion are proud to worksurface.
- When installed into a 1 3/4" (30mm) worksurface, the Flip Top Unit will extend below the worksurface.

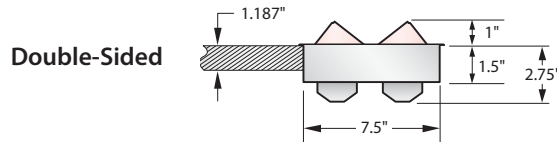
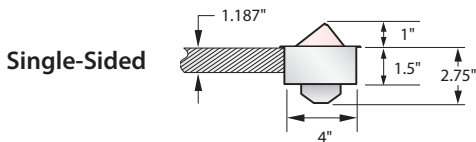

Flip Top Unit Bezel Dimensions:

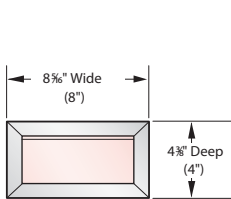

• 2.2 • 3.1
Single-Sided

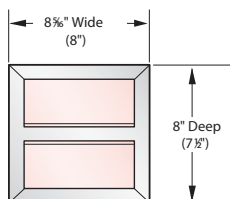

• 2.2 • 3.1
Double-Sided

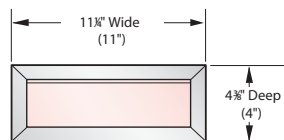

• 3.3 • 4.2
Single-Sided

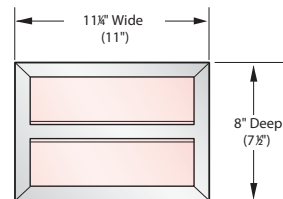

• 3.3 • 4.2
Double-Sided

Note Cutout dimensions are in parentheses ().

The Flip Top Unit includes multiple data jack adapters to accommodate most field supplied data jacks. Also included are blank data covers to be used if no data access is needed. Data jacks are field supplied.

- 15 amp rated simplex power receptacles
- Data information access ports

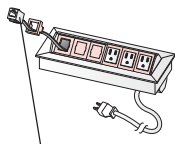

Data jack adapters standard in white; included with Flip Top Unit. (See manufacturer list for field supplied data jacks).

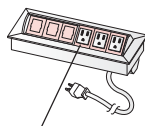

Perimeter edge of power receptacles and data ports faceplate standard in white.

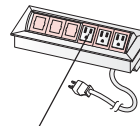

Simplex power receptacles standard in white; included with Flip Top Unit.

Includes blank data covers and data jack adapters.

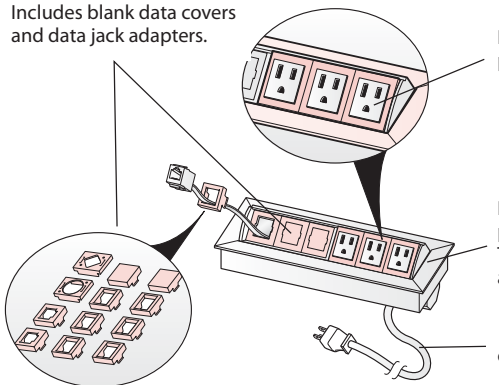

Includes simplex power receptacles.

Flush mount plate and pop-up portion of Flip Top Unit standard in anodized finish.

12, 15 Amp black cord with plug.

Data Jack Adapters Included

Manufacturer's List of Field Supplied Data Jacks

Systemax/CommScope
Tyco SL and 110 Connect Series Modular Jacks
Siemon Keystone Style
Allen Tel Versa Tap Series
Leviton Quick Port® Series
Nordx Keystone Style
Tyco SL Coupler Series
ADC (Krone) 6000 Series
Hubbell Xcelerator™ Keystone Series
Blank (no coupler/jack)
Ortonics TracJack Series
Panduit Mini-Com Series
Microphone Jack/3-Pin XLR (solder type only)
Video Monitor Jack/DB-15 (panel mount solder style)

Power Basics

3-Circuit

- As many as three separate 20-Amp rated circuits from one power feed module.
- 8-Wire system enclosed in one power distribution assembly:
 - 3 hot wires
 - 3 neutral wires
 - 1 common ground wire
 - 1 isolated ground wire
- Separate neutrals, one dedicated to each circuit, are capable of carrying computer-quality power.

4-Circuit

- As many as four 20-Amp rated circuits from one power feed module.
- 8-Wire system enclosed in one power distribution assembly:
 - 4 hot wires
 - 2 neutral wires
 - 1 common ground wire
 - 1 isolated ground wire
- 4-Circuit product is available in either a 2+2 configuration or a 3+1 configuration. Both configurations utilize a shared neutral conductor for at least two circuits. All circuits have access to either common or isolated ground.

Hardwire

- Components available to meet Chicago and other similar hardwire configurations.
- Consists of infeeds, junction boxes, and mounting hardware.
- Field supplied wire and receptacles allow for a variety of applications for specific needs.

Panel Power Options:

- 3-Circuit and 4-Circuit: Panel options specified with 3- or 4-Circuit power include a power distribution assembly and a flex connector.
- New York City (NYC): The New York City option includes the same components as those listed above but are shipped separate from the panel and require field installation.
- New York Port Authority (NYPA): The New York Port Authority option includes a metal raceway cover and is available with or without the power components.
- Hardwire: The hardwire option includes raceway covers for receptacle access. Hardwire electrical raceway kits and receptacle covers must be separately specified. In addition, receptacles, conduit, wiring, and other associated components must be field supplied.

3- and 4-Circuit Overview

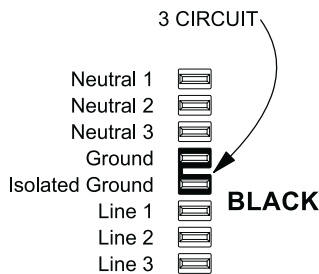

3-Circuit/Separate Neutrals

This option provides three circuits, each with its own neutral.

- Aligns with the 3 phase national power grid and most North American buildings.
- Is compatible with the following building power configurations:
 - 3 phase (208Y/120V)
 - Three wire single phase (120/240V)
 - Single phase (120V)
- Offers the most adaptability to special power needs such as:
 - multiple power sources
 - facility energy control
 - isolation of high harmonic loading
- Features receptacles with patented on-site circuit access programmability (available only on Power Base for furniture).
- Offers receptacles in common ground or isolated ground configurations.

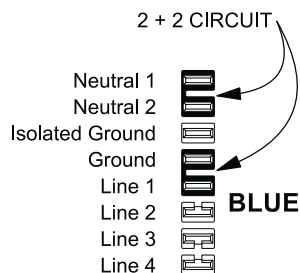

4-Circuit/2+2

This option provides four circuits, two circuits share neutral #1, two circuits share neutral #2.

- Provides more circuits (4 vs. 3) for each homerun from the electrical closet, which can reduce the installed cost per circuit.
- Is compatible with the following building power configurations:
 - 3 phase (208Y/120V)
 - Three wire single phase (120/240V)
- Is sometimes less adaptable to special power needs such as multiple power source or facility energy control.
 - Special power needs are typically planned in sets of two circuits
 - In some cases, 10 gauge shared neutral may not fully isolate circuits
- Modular receptacles have fixed circuit access.
- Offers receptacles in common ground or isolated ground configurations.

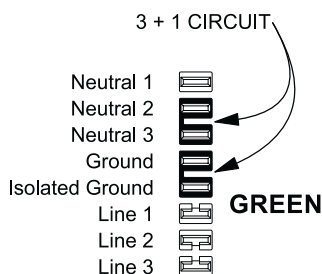

4-Circuit/3+1

This option provides four circuits, three circuits share neutral #1, circuit #4 has a separate neutral.

- Provides more circuits (4 vs. 3) for each homerun from the electrical closet, which can reduce the installed cost per circuit.
- Is compatible with the following building power configurations:
 - 3 phase (208Y/120V)
- Is sometimes less adaptable to special power needs such as multiple power source or facility energy control.
 - Special power needs are typically planned only using circuit #4
 - In some cases, 10 gauge shared neutral may not fully isolate circuits
- Modular receptacles have fixed circuit access.
- Offers receptacles in common ground or isolated ground configurations.

Power Planning General Guidelines and Checklist

All power application information is found in the corresponding component Price List, system-specific specification guide, and Power Base Planning Guide.

Verify the Following:

In: Routing power from the building into the furniture.

- Power feed length will reach building location.
- Infeed fits panel type (UniGroup Too, PLACES, or UniGroup) and width.
- Infeed location is not occupied by a:
 - Receptacle
 - Port Kit (attaches to receptacle location on PDA)
- Power raceway cover for external infeed location.

Through: Routing power through the furniture.

- Power Distribution Assemblies (PDAs) are located where power access is needed.
- Horizontal Power Routing:**
 - Base Power
 - Spanning connector for each 3-Way/4-Way connection where return panels are non-powered.
 - 12" (305mm) panel is specified as a powered panel where needed.
 - All adjacent panels have base power, 12" (305mm) power connectors cannot be coupled together.

Out: Getting power out of the furniture so it can be used.

- Maximum receptacle quantity per feed is not exceeded (13 United States/10 Canada).
 - Fixed circuit receptacles are specified for all circuits.
- Ability to access power through base raceway receptacle port.
- Power/communication port kit is used in a powered panel.

General Power Application Guidelines:

- Power break markers are indicated where needed.
- Panel hung components and floor supported storage do not block receptacle access.
- Do not mix 3-Circuit and 6-Circuit with 4-Circuit components.
- Do not mix 2+2 and 3+1 components.
- Components have unique polarity key and color coding (3-Circuit = black, 6-Circuit = ivory, 2+2 = blue, and 3+1 = green).

Power Distribution for Hardwire Applications

Hardwire power applications are designed to address non-modular power planning solutions.

1. Power distribution from building-to-panel.
2. Vertical power distribution.
3. Horizontal power distribution.

Infeeds	Applications
1 Base Feed	48" (1219mm) or as required
2 Top Feed	Ceiling Height (H) + 18" (457mm)

Panel Applications	Panel Applications
3 Between two junction boxes on one panel	Panel Width (W) – 17" (432mm)
4 Between junction boxes if one per panel	Panel Width (W) – 8" (203mm)
5 Across panel-to-panel connection	9" (229mm)
6 Across 3- or 4-Way connection	11" (279mm)

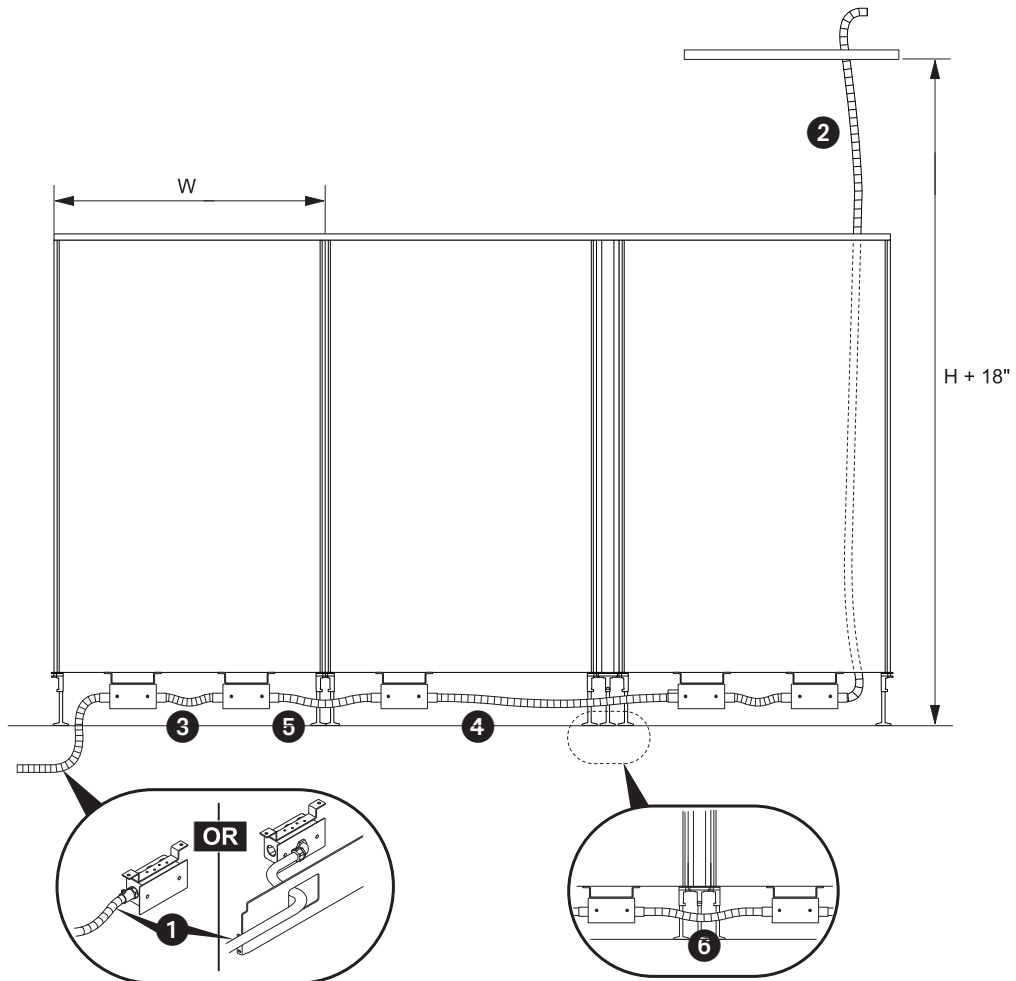

International Power Management

International Power Planning

For power applications outside North America, we recommend the use of Power Logic soft wiring components. Power Logic offers a system of single circuit power cords and receptacle modules that fit into our non-powered Base Raceway. Receptacle Modules are offered with two sockets (three and four socket versions also available). Each Receptacle Module has sockets, switches, and fuses that are appropriate for each country around the world.

- Use a Power Entry Cord to bring power into the Panel's Base Raceway and feed a Receptacle Module mounted to the Base Raceway Cover.
- Use additional Cords to route power to additional receptacles as needed.
- Use a Splitter to branch out in multiple directions (up to four).

Contact the Power Logic regional sales office in your area to help with planning details to assure local electrical code compliance. Contact Power Logic through their website, www.powerlogic.net, or through their corporate offices in Cape Town, South Africa at 27-21-704-1450. Power Logic also offers power solutions for desk top, conference table, or freestanding power applications.

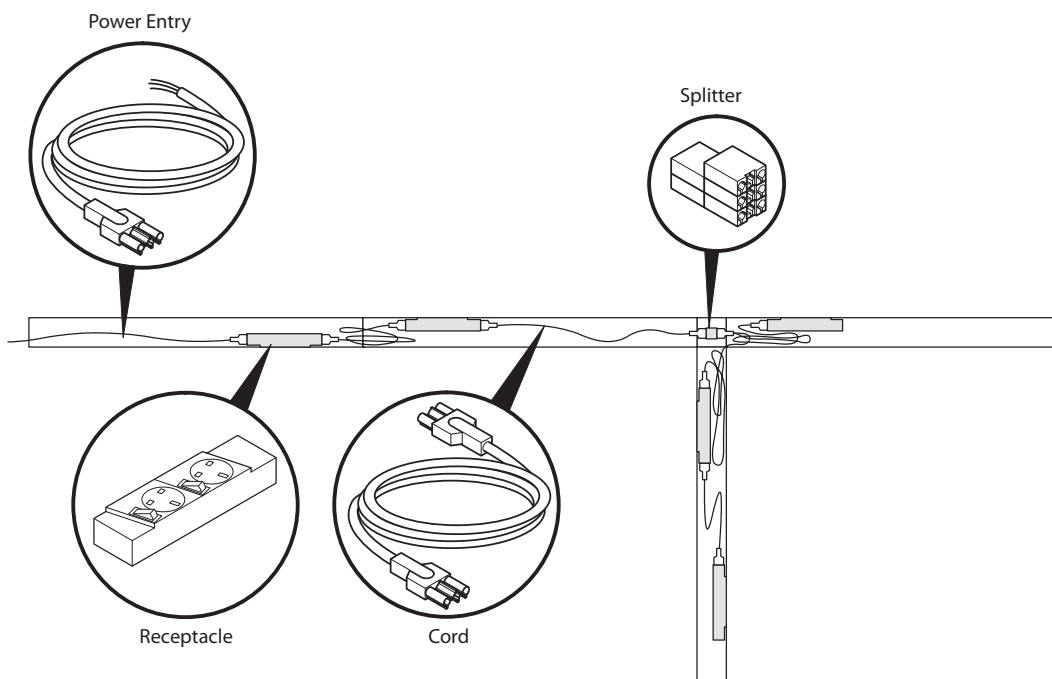

Cable Management Introduction: UniGroup Too and UniGroup

UniGroup Too and UniGroup addresses the distribution of communication cables with panel-integrated cable pathways and access points. A separately specified horizontal Expanded Top Cap Raceway is also available for use with UniGroup (see Price List).

Cables can be routed through these pathways:

- A. Panel base pathway
- B. Cable management pole channel
- C. Top feed module channel

Cables can be accessed at these locations:

- D. Up to four base raceway receptacle sites per panel (using bottom corner of receptacle).
- E. Up to two communication ports in ported base raceway covers (per side).
- F. Panel Port Kit

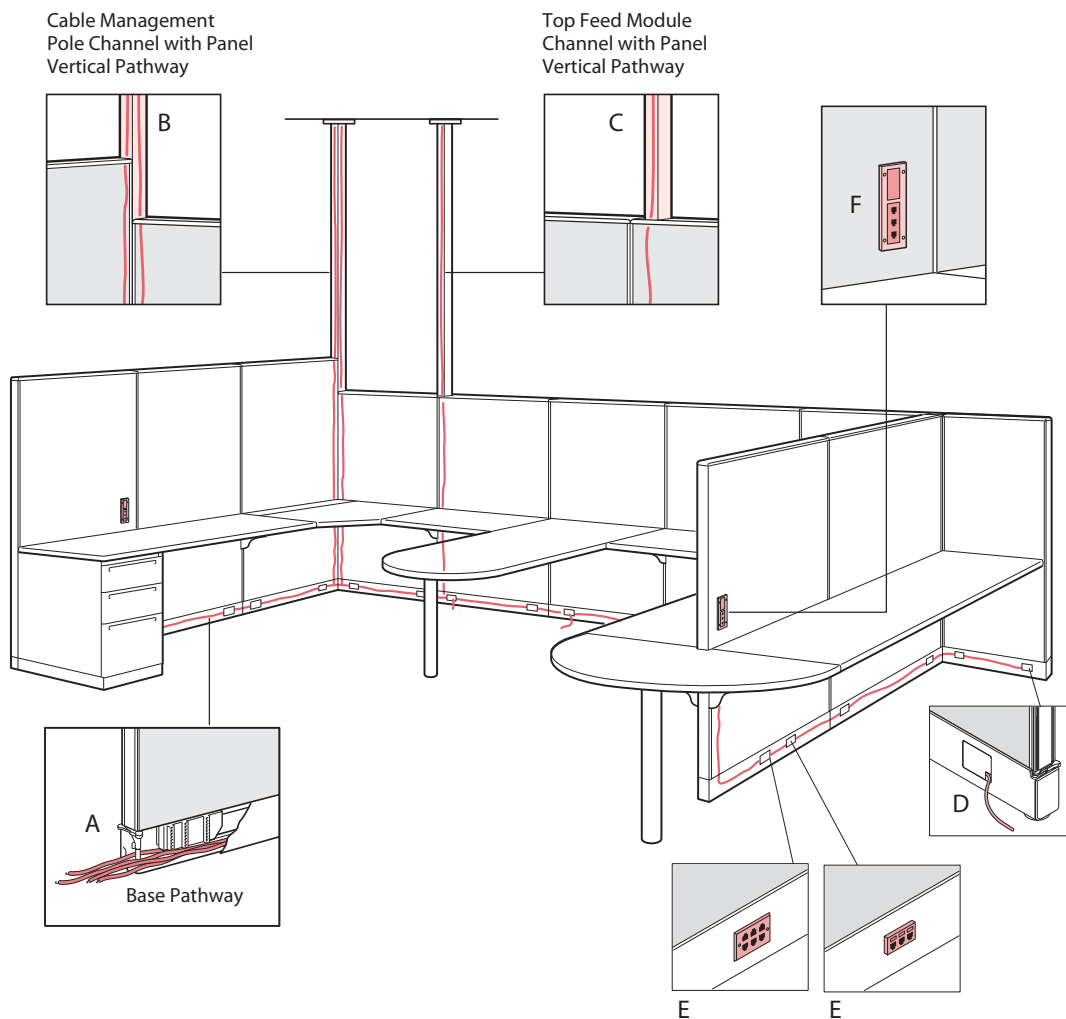

Cable Management Introduction: PLACES

PLACES addresses the distribution of communication cables with panel-integrated cable pathways and access points.

Cables can be routed through these pathways:

- A. Panel base pathway
- B. Panel top pathway
- C. Panel vertical pathway
- D. Top feed module channel
- E. Cable management pole

Cables can be accessed at these locations:

- F. Up to four base raceway receptacle sites per panel (using bottom corner of receptacle).
- G. Up to two communication ports in ported base raceway covers (per side).
- H. Panel Port Kit

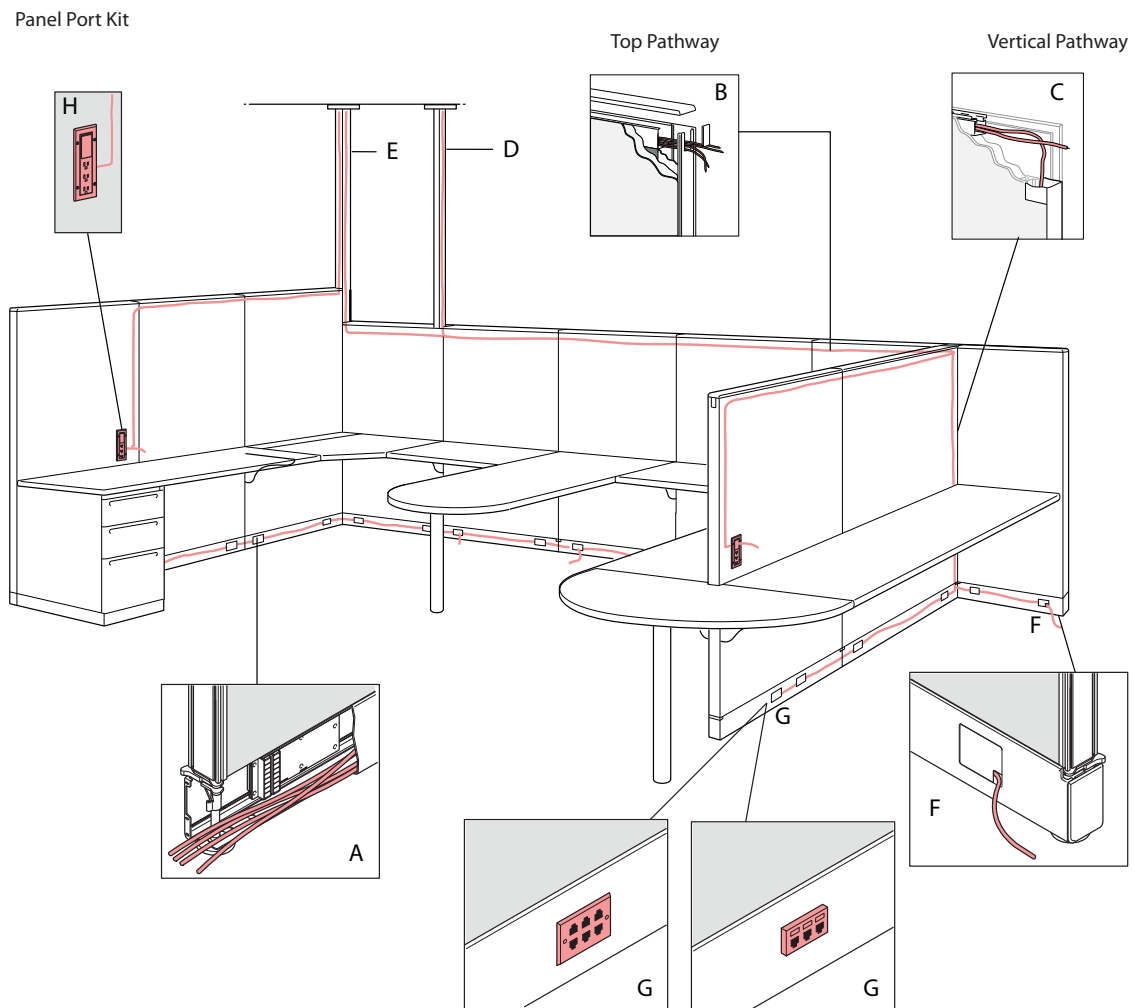

Cable Management Introduction: UniGroup Too, UniGroup, and PLACES

Communication Cable Routing

UniGroup Too, UniGroup, and PLACES panels normally accept building cable infeeds from either floor or ceiling locations. Floor infeeds go directly to the base pathway at a variety of locations, and ceiling infeeds offer several options.

UniGroup panels have three integrated pathways for cable routing throughout the system installation. There are four access points in the base raceway cover, and two more at the open ends of the raceway. From these access points, cables can be routed through the base cable pathway or up through the vertical cable pathways.

Cable management poles and top feed modules integrate with the panel's top, base, and vertical pathways to route cables from ceiling infeeds.

Cable Capacities: 2" (51mm)-thick Standard Panel

The chart below shows the number of various sized 4-pair unshielded twisted pair (UTP) cables that can be routed through specific pathways of the 2" (51mm)-thick standard panel. Cable capacities are based on 0.20" (5mm), 0.28" (7mm), and 0.30" (8mm) diameter cables at 60% and 40% fill capacity.

UniGroup Too, UniGroup, and PLACES Pathways

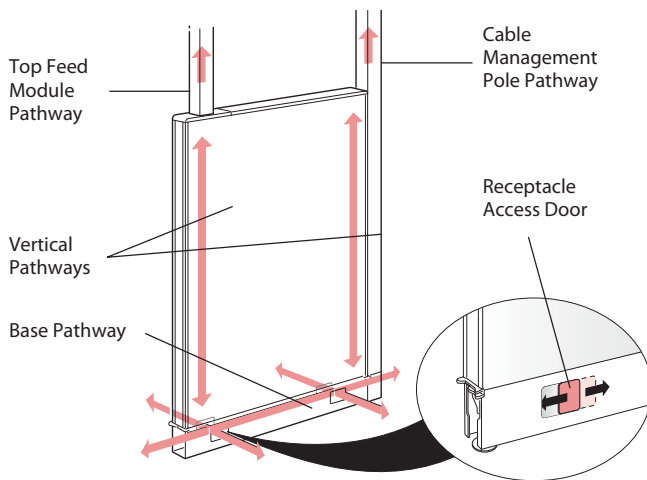

PLACES Top Panel Pathway

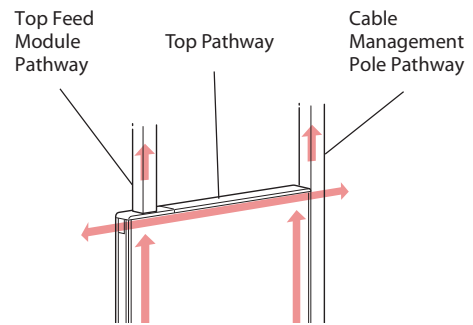

Pathway Capacities

Cable Pathway Area

Cable Capacity

	Cable Pathway Area		60% FILL			40% FILL		
	SQ. IN.	SQ. MM.	0.20" (5MM)	0.28" (7MM)	0.30" (8MM)	0.20" (5MM)	0.28" (7MM)	0.30" (8MM)
Example								
One square inch pathway	1.0	645	19	10	8	13	6	6
Fabric, Laminate, Wood, and Glass Panel (unless otherwise noted)								
Base Raceway, Powered	1.1	710	21	11	9	14	7	6
Base Raceway, Non-Powered	5.6	3613	107	55	48	71	36	32
One Vertical Pathway (2/panel, 0.9 each)	0.9	581	17	9	8	11	6	5
Top Pathway (PLACES)	1.6	1032	31	16	14	20	10	9
Top Glazed/Open Frame Pathway (PLACES)	1.4	903	27	14	12	18	9	8
One Vertical Glazed/Open Frame Pathway (2/panel @ 1.2 each)	2.4	1548	46	23	20	31	16	14
Top Feed Module	1.3	839	25	16	10	16	10	6
Cable Management Pole	2.8	1806	54	27	24	36	18	16
Expanded Top Cap (optional for UniGroup)	2.9	1871	55	28	25	37	19	16

Note TIA/EIA 569A suggests a cable fill of 40% for planning and up to 60% for unplanned additions.

Cable Management: UniGroup Too and UniGroup

Ceiling-Height Cable Management Poles: One- and Two-Channel

- Carry cables from the space above the ceiling to panel pathways.
- Available in 10' (3048mm) length.
- Made with two-piece construction.
- Dedicated to communication and data cabling only; offering more capacity than the top feed module.
- Two-channel design provides access to cables on both sides of a panel from adjacent workstations — at expanded top cap height and at the base raceway cover.

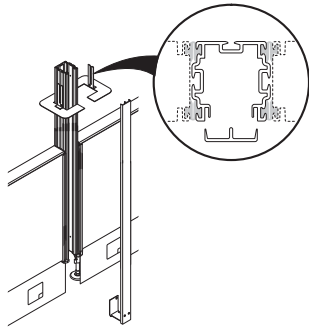

Inline End-of-Run Condition
(with One Channel detail)

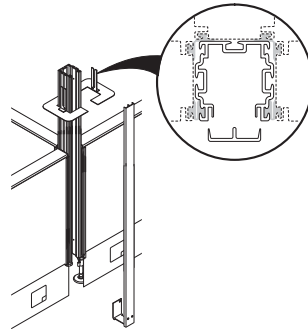

3-Way End-of-Run Condition
(with One Channel detail)

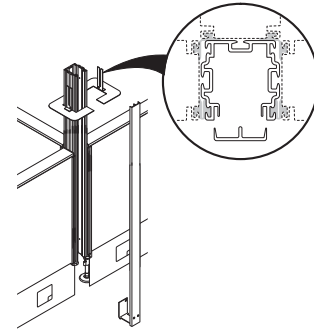

4-Way End-of-Run Condition
(with One Channel detail)

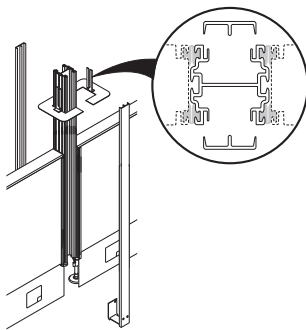

Inline End-of-Run Condition
(with Two Channel detail)

Note A 4-Way condition can be met with a 3-Way cable management pole.

Cable Management: PLACES

Ceiling-Height Cable Management Poles

- Carry cables from the space above the ceiling to panel pathways.
- Available in two lengths: 10' (3048mm) and 12' (3658mm).
- Made with two-piece construction; the top piece is slotted for cable routing into the panel's top pathway.
- Dedicated to communication and data cabling only, offering more capacity than the top feed module.

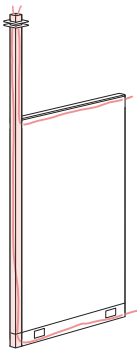

End-of-Run Condition

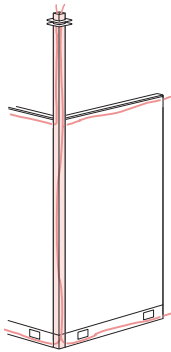

2-Way 90° Condition

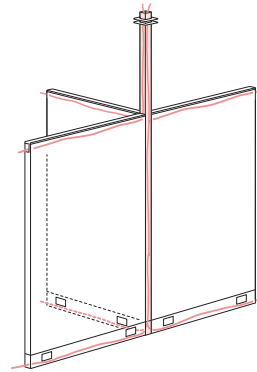

3-Way Condition

Note A 4-Way condition can be met with a 3-Way cable management pole.

Panel-Height Cable Management Poles

- Manage top-to-base cable routing in 90° corner and 180° 3-Way panel junctions.

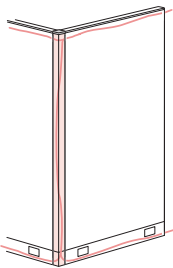

2-Way 90° Condition

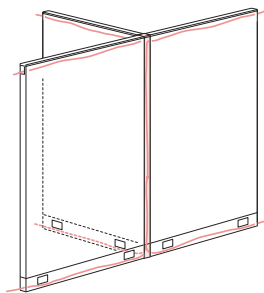

3-Way Condition

Cable Management: PLACES

Variable-Height Cable Management Posts

- Used in conditions where panel heights differ in one panel run.
- Permits the passage of cables from the top pathway of one panel into the top pathway of another panel.
- Available in wood, fabric, or painted metal surfaces.
- Field cut to appropriate length if necessary.

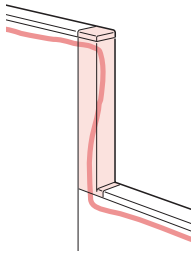

In-line Condition

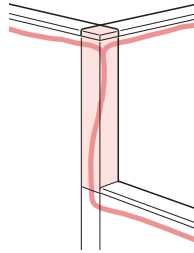

3-Way
90° Condition

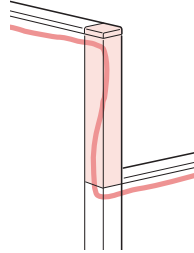

2-Way
90° Condition

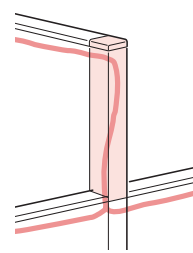

3-Way
180° Condition

Cable Management: UniGroup Too and UniGroup

Cable Bend Radius

When planning the routing of communication cables through UniGroup Too and UniGroup panels, specifiers must consider the bend radius at the panel-to-panel connections and within the panel pathways. These illustrations depict the minimum and maximum bend radii for cables in UniGroup Too and UniGroup panels:

A Top Feed Module to Expanded Top Cap Raceway (Optional for UniGroup)

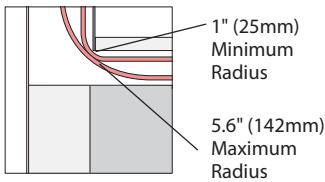

B Expanded Top Cap Pathway (Optional for UniGroup)

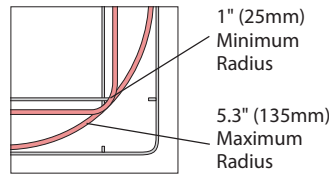

C Cable Management Pole to Expanded Top Cap Raceway (Optional for UniGroup)

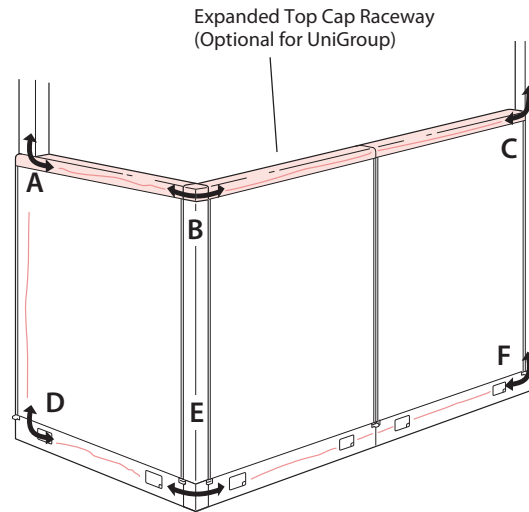
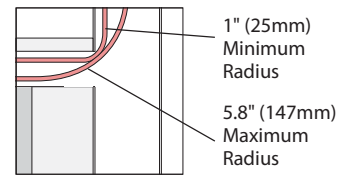

D Vertical Pathway to Base Raceway

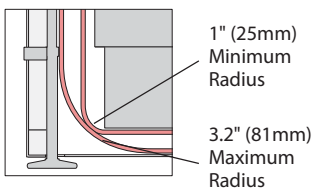

E Base Raceway

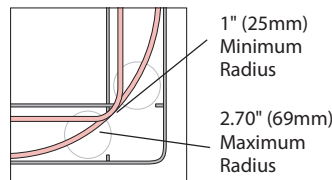

F Cable Management Pole to Base Raceway

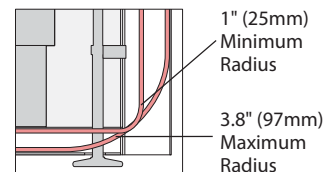

Cable Management: PLACES

Cable Bend Radius

When planning the routing of communication cables through PLACES panels, specifiers must consider the bend radius at the panel-to-panel connections and within the panel pathways. These illustrations depict the minimum and maximum bend radii for cables in PLACES panels:

A Top Pathway to Vertical Pathway

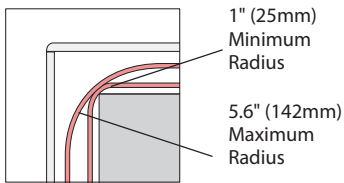

B Top Pathway

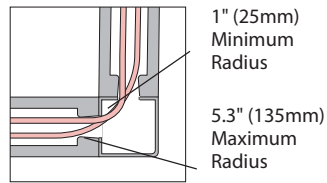

C Cable Management Pole to Top Pathway

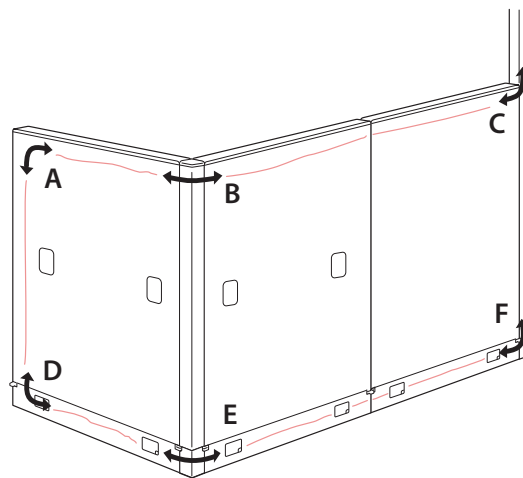
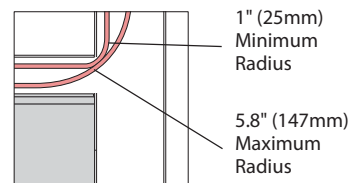

D Vertical Pathway to Base Raceway

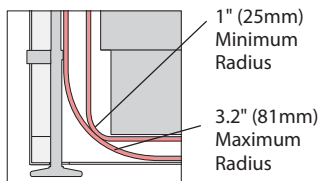

E Base Raceway

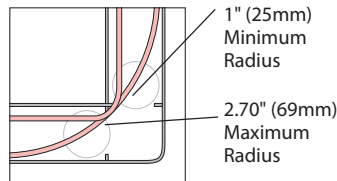

F Cable Management Pole to Base Raceway

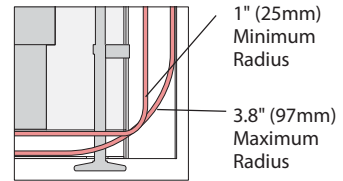

Cable Management: UniGroup Too, UniGroup, and PLACES

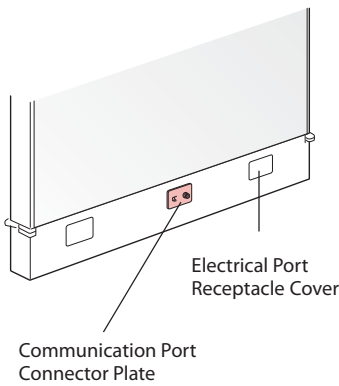

Communication Cable Access

UniGroup Too, UniGroup, and PLACES panels provide two access points where communication cabling can be terminated to separately specified connector plates: ported (base) raceway covers and field installed port kits.

Ported (Base) Raceway Covers

- Retrofit to powered panels.
- Available in six variations to accommodate different connector modules (see examples below).
- Modular Furniture Telecommunications plate opening measurements: 1.38" (35mm) high x 2.71" (69mm) wide, with snap-in installation.
- Wall outlet (single-gang) plate opening measurements: 2.25" (57mm) high x 3.75" (95mm) wide, with screw and backer plate installation.



Modular Furniture Telecommunications Plate Example (snap-mounted)

RACEWAY WIDTH	A
18" (457mm)	8" (203mm)
24" (610mm)	9.2" (234mm)
30" (762mm)	12.2" (310mm)
36" (914mm)	15.2" (386mm)
42" (1067mm)	18.2" (462mm)
48" (1219mm)	21.2" (538mm)
54" (1372mm)	24.2" (615mm)
60" (1524mm)	27.2" (691mm)

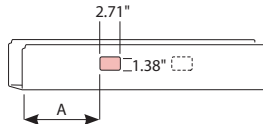

One Modular Furniture Telecommunications Plate opening* (non-powered condition)

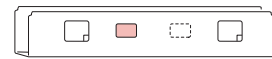

One Modular Furniture Telecommunications Plate opening* (powered condition)

RACEWAY WIDTH	B	C
36" (914mm)	9.5" (241mm)	23.7" (602mm)
42" (1067mm)	9.5" (241mm)	29.7" (754mm)
48" (1219mm)	9.5" (241mm)	35.7" (907mm)
54" (1372mm)	9.5" (241mm)	41.7" (1059mm)
60" (1524mm)	9.5" (241mm)	47.7" (1212mm)

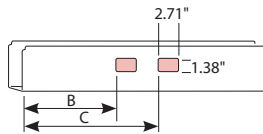

Two Modular Furniture Telecommunications Plate Openings (non-powered condition)

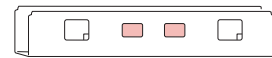

Two Modular Furniture Telecommunications Plate Openings (powered condition)

* Single side communication port opening shows port offset from center of panel to allow back-to-back connector installation.

Tips

- Data plates (i.e., modular furniture and single gang faceplates) must be specified separately. Refer to the Voice and Data Price List (or field supplied).
- Order panels with no raceway cover when separately specifying ported (base) raceway covers.

Cable Management: UniGroup Too, UniGroup, and PLACES

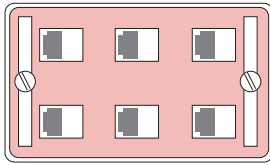

Wall Outlet (Single-Gang) Plate Example
(screw and backer plate installation)

RACEWAY WIDTH	D
42" (1067mm)	14.7" (373mm)
48" (1219mm)	17.7" (450mm)
60" (1524mm)	23.7" (602mm)

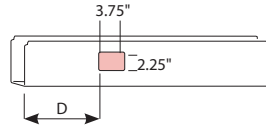

One Standard Wall Outlet
(single-gang) Opening*
(non-powered condition)

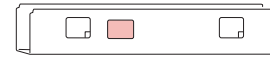

One Standard Wall Outlet
(single-gang) Opening*
(powered condition)

* Single side communication port opening shows port offset from center of panel to allow back-to-back connector installation.

Tips

- Data plates (i.e., modular furniture and single gang faceplates) must be specified separately. Refer to the Voice and Data Price List (or field supplied).
- Order panels with no raceway cover when separately specifying ported (base) raceway covers.

The following manufacturers offer faceplates that fit modular furniture telecommunications openings. For additional details, contact your local Haworth Technical Representative.

Systemax/CommScope

Tyco

Siemon

Leviton

ADC

Hubbell

Belden

Ortonics

Panduit

Hubbell

Cable Management: UniGroup Too, UniGroup, and PLACES

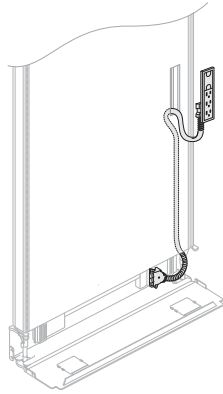

Port Kit

- Accommodates one Modular Furniture Telecommunications faceplate.
- Modular Furniture Telecommunications opening measures 1.38" (35mm) wide by 2.71" (69mm) high.

Cable Management: UniGroup

Expanded Top Cap Raceway (Optional for UniGroup)

- Provides horizontal cable management at top of panel.
- Increases the cable storage capacity of a UniGroup panel, accommodating fifty five 0.20" (5mm) Category 5.
- Replaces panel's top cap and adds 2" (51mm) to the panel's height.
- Five (5) separately specified finish caps are used to join expanded top caps in a panel run.

Expanded Top Cap Raceway Applications

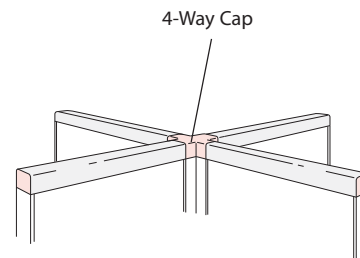
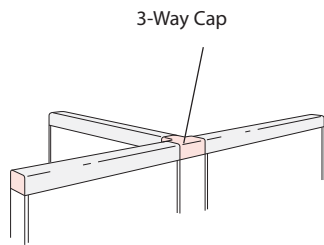
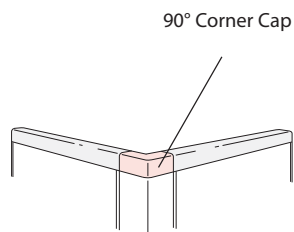
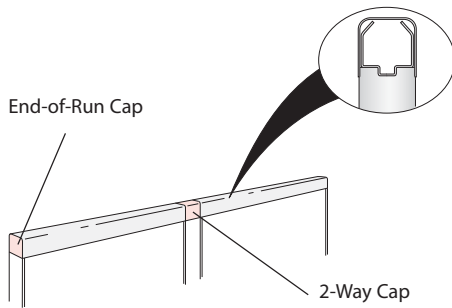

3-Way Condition

4-Way Condition



This page intentionally left blank.



This page intentionally left blank.

Power Management

Modesty Panel/Power and Cable Management

The power and cable management modesty panel is required to attach a Power Distribution Assembly (PDA) to a Tactics table. The modesty panel features a generous power and cable management channel for easy access, lay-in of cords and cables, installation of PDAs and access to power and communication receptacles.

Specification Tips

- For use with 48"–96" (1219mm–2483mm) wide rectangular T-Leg or C-Leg Tactics tables when equipped with Modesty Panel/Power and Cable Management and Power Distribution Assembly.
- Specify modesty and Power Distribution Assembly to match table width.
- Specify appropriate table-to-table power connector and J-Channel when spanning power between powered tables.
- A non-powered table can be powered with the addition of the Modesty Panel/Power and Cable Management and the Power Distribution Assembly.

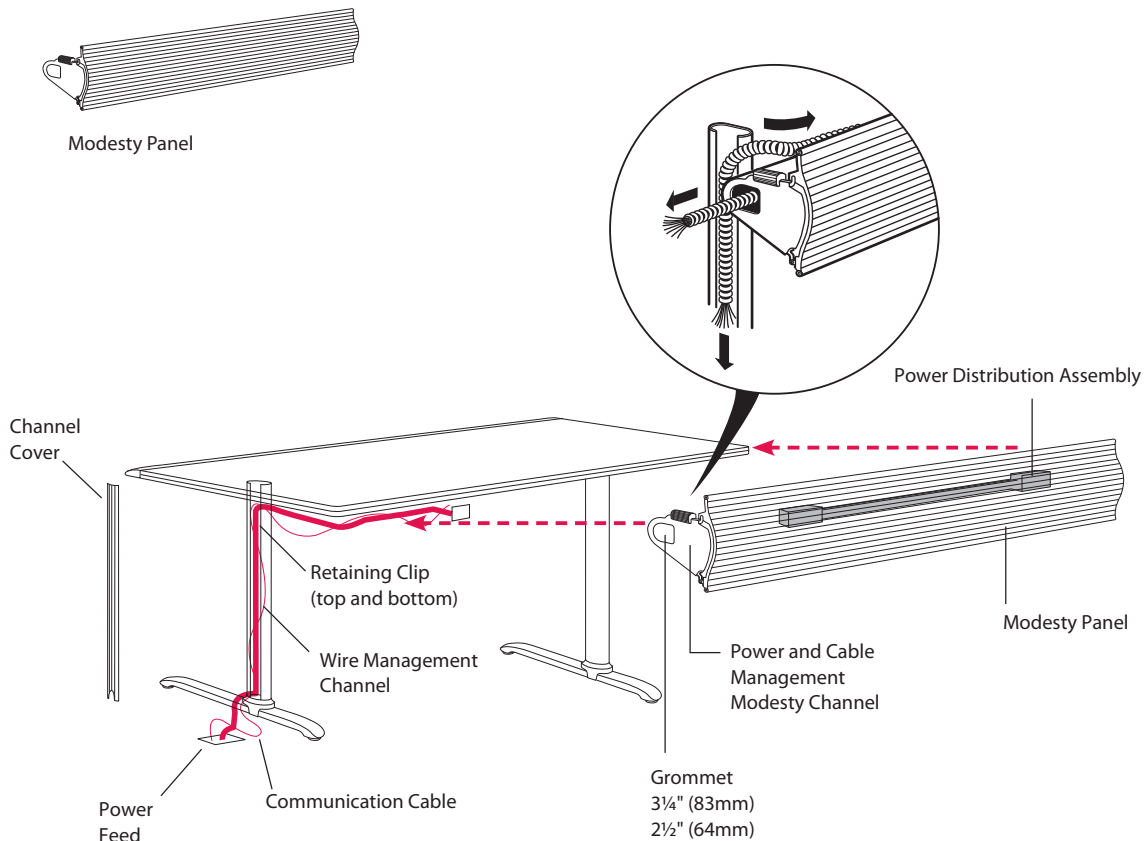

Power Management

J-Channel

The J-Channel is required when using the table-to-table power connector to span power from one powered table to adjacent powered tables. Applications include in-line, beneath 15°, 30°, 45°, 90° pie connector top, and beneath CPU Bridge. The J-Channel is also used to provide wire management below table tops and connecting tops.

Specification Tips

- 72" (1829mm) J-Channel can be used for cord management and may be field cut.

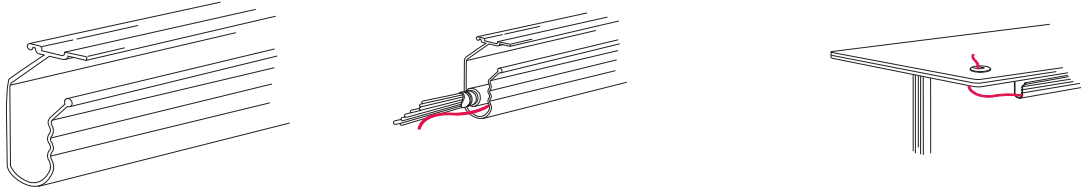

Connector Applications



Base Feed Modules

Base Feed Module: Hardwire Connection

The module is used to transition from building wiring to modular power within tables. One end is hardwired to the building wiring and the modular end snaps into the Power Distribution Assembly (PDA) in the tables.

Specification Tips

- For use with 48"–96" (1219mm–2483mm) wide rectangular T-Leg or C-Leg Tactics tables when equipped with Modesty Panel/Power and Cable Management and Power Distribution Assembly.
- Infeeds are routed through leg wire management channels and can enter the modesty channel at either end of a table.
- Wire management leg is standard on all C-Leg tables but must be specified for T-Leg.
- Conduit is 72" (1829mm) long.

Power Location

- Floor
- Column
- Wall

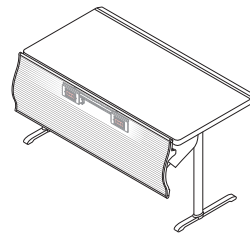
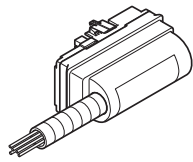

Base Feed Module

Base Feed Module: Concealed Hardwire Connection

The module is used to transition building wiring to modular power within the tables. A junction box is mounted to the table and has a modular connector which snaps into the Power Distribution Assembly (PDA). Field supplied conduit is used to bring power from the building to the junction box.

Specification Tips

- For use with 48"–96" (1219mm–2483mm) wide rectangular T-Leg or C-Leg Tactics tables when equipped with Modesty Panel/Power and Cable Management and Power Distribution Assembly.
- Field supplied conduit routes through leg wire management channels and can enter the modesty channel at either end of a table.
- Wire management leg is standard on all C-Leg tables but must be specified for T-Leg.

Power Locations

- Floor
- Column
- Wall

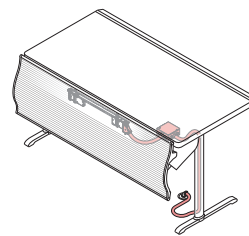
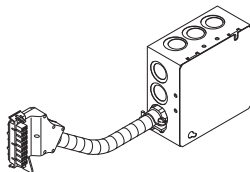

Conduit (field supplied)

Note New York City code compliant.

Base Feed Modules

Single Circuit Base Feed Module: Receptacle Connection with Power Cord

The module is used to transition from building wiring to modular power within the tables. The cord end is plugged into a building receptacle and the modular end snaps into the Power Distribution Assembly (PDA) in the table. Only circuit one is powered by a cord feed. National codes restrict the length of the cord; 24" (610mm) in the United States, 72" (1829mm) in Canada.

Specification Tips

- For use with 48"–96" (1219mm–2483mm) wide rectangular T-Leg or C-Leg Tactics tables when equipped with Modesty Panel/Power and Cable Management and Power Distribution Assembly.
- Infeeds are routed through leg wire management channels and can enter the modesty channel at either end of a table.
- Wire management leg is standard on all C-Leg tables but must be specified for T-Leg.
- Plan to position one table in each connected run of tables within 18" (457mm) of the power feed when a power cord is used.
- Not for use with isolated ground receptacles.

Power Location

- Floor
- Column
- Wall

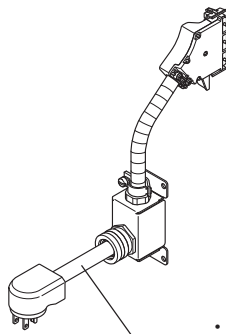

- 24" (610mm) in the United States
- 72" (1829mm) in Canada

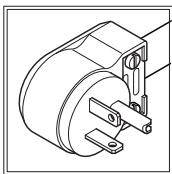
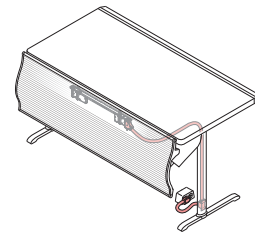

20 Amp (USA)

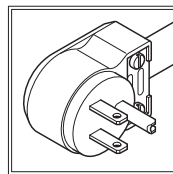

15 Amp (Canada)

Base Feed Modules

Raised Floor Infeed Base Feed Module: Internal

The module is used to make plug-and-play connections between Power Base AI underfloor modular power components and the power distribution assembly (PDA) in a table.

Specification Tips

- For use with 48"–96" (1219mm–2483mm) wide rectangular T-Leg or C-Leg Tactics table when equipped with Modesty Panel/Power and Cable Management and Power Distribution Assembly.
- Infeed conduit routes through leg wire management channels and can enter the modesty channel at either end of a table.
- Wire management leg is standard on all C-Leg tables but must be specified for T-Leg.
- Can only be connected to Power Base AI underfloor power system.
- Black split tubing may be field supplied to cover any exposed galvanized metal conduit.

Power Location

- Power Base AI

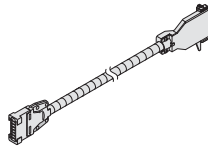

Internal Base Feed

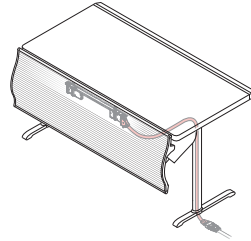

Power Distribution Assembly (PDA)

A powered distribution assembly (PDA) is used to distribute power through the tables. The PDA is used to connect all other electrical components. The PDA has two connector ports and two receptacle ports at each end. The connector ports on a PDA provide for the connection of power connectors. The receptacle port is used for receptacles and the connection of base feeds.

Specification Tips

- For use with 48"–96" (1219mm–2483mm) wide rectangular T-Leg or C-Leg Tactics tables when equipped with Modesty Panel/Power and Cable Management.
- Specify appropriate table-to-table power connector and J-Channel when spanning power between powered tables.
- A non-powered table can be powered with the addition of the Modesty Panel/Power and Cable Management and the Power Distribution Assembly.
- 48"(1219mm) through 84" (2134mm) wide PDA kit ships with one power distribution assembly.
- 96" (2483mm) wide PDA kit ships with two power distribution assemblies and one flexible power connector.

Power Distribution Assembly

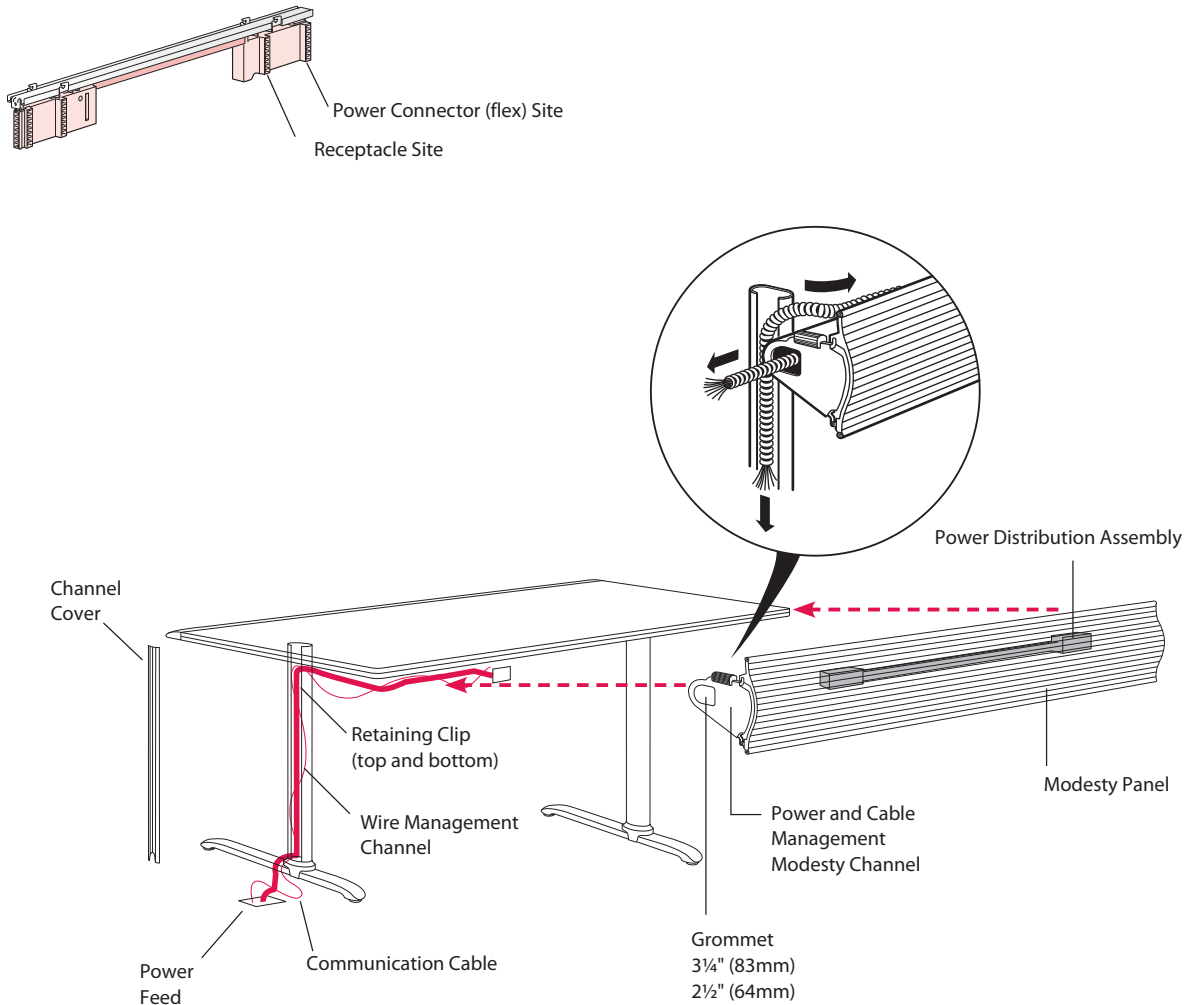

Power Connectors

Table-to-Table Power Connector

The connector is used to span power from one powered table to another adjacent powered table. Applications include in-line, beneath 15°, 30°, 45°, and 90° pie connector tops and beneath CPU Bridge.

Specification Tips

- Requires appropriate J-Channel.

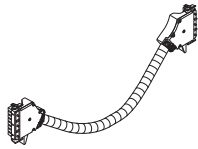

Connector Applications

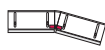

15°

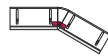

30°

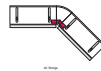

45°



90°

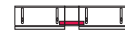

CPU Bridge

Power Connectors

Receptacles

Receptacles attach to the power distribution assembly (PDA) to allow access to the circuits carried through the panel. The 3-Circuit 15 Amp receptacles have a circuit selectable feature that allows each receptacle to access either circuit 1, 2, or 3 in the field by simply sliding the connector to one of three positions.

Specification Tips

- 15 Amp receptacle configuration is NEMA 5-15R.
- 20 Amp receptacle configuration is NEMA 5-20R.
- 3-Circuit 20 Amp and 4-Circuit receptacles have fixed circuit access and are not field programmable. Specify appropriate number of receptacles for each circuit.

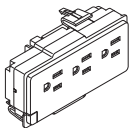

3-Circuit 15 Amp

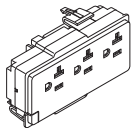

3-Circuit 20 Amp

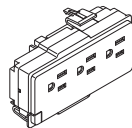

4-Circuit 15 Amp

POWER CONFIGURATION	RECEPTACLE IDENTIFIER			
2+2	1	2	3	4
3+1	A	B	C	D
3-Circuit (20 amp)	I	II	III	NA

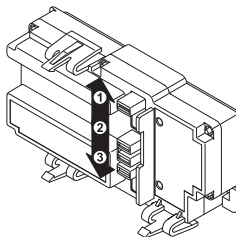

3-Circuit 15 Amp Programmable Receptacle

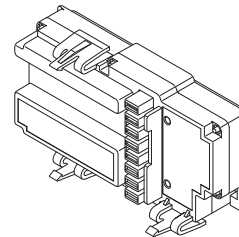

- 3-Circuit 20 Amp
- 4-Circuit 15 Amp
- 4-Circuit 20 Amp

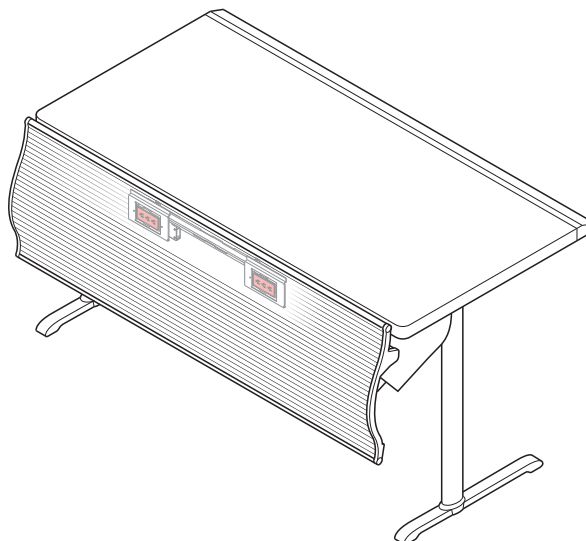

Receptacles

Desktop Port

Desktop ports provide three 15-Amp outlets and data jacks in a tabletop housing that flips up for access or can be closed for unobstructed work space.

Specification Tips

- Power cord plugs into a panel or building receptacle outlet.
- Desktop ports cannot be linked (daisy chained) together.
- Cord use should be reviewed by local authorities (electrical inspector) prior to ordering.
- Modular furniture telecommunications faceplate must be field supplied.

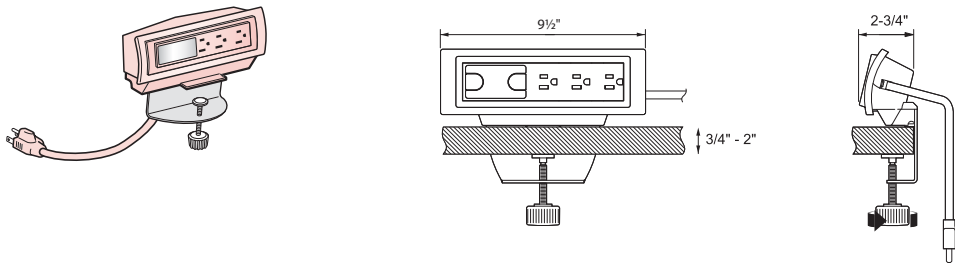

Flip Top Unit

Flip Top Unit provides 15 Amp outlets and data jacks in a desktop housing that flips up for access or can be closed for unobstructed work space.

Specification Tips

- Flip Top Unit must be field installed on tables by field cutting hole in standard weight tops only.
- Hardwired applications should be reviewed by local authorities (electrical inspector) prior to ordering.
- Corded flip top units with four receptacles utilize a fused plug that may block adjacent building receptacle outlet.

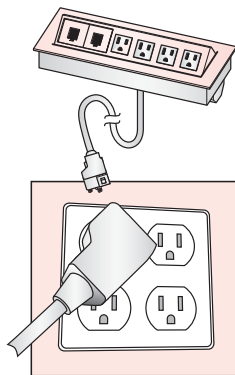
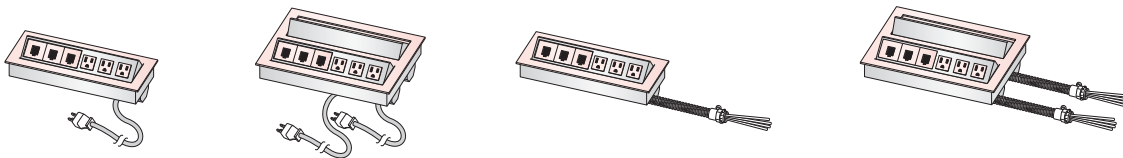

Fused Plug Detail
(for Flip Top Units with four or more outlets)

Receptacles

Topping a Conference Table with Power and Communications

Bringing power and communications access to the top surface of a conference table is easy with the Tactics table dome. A black half-sphere that drops into a 3" opening in the table top, the dome can be specified with power receptacles or plates into which you can install voice or data ports (these are not available from Haworth; purchase them from local suppliers). Field-installed into any table (except those with lightweight tops), the dome features 6' power cords with 15-Amp plugs. Whenever you plan to outfit a conference table with the table dome, be sure to specify the table with wire-management channels in the legs, and to order a length of J-Channel to route the dome's power cords beneath the table top.

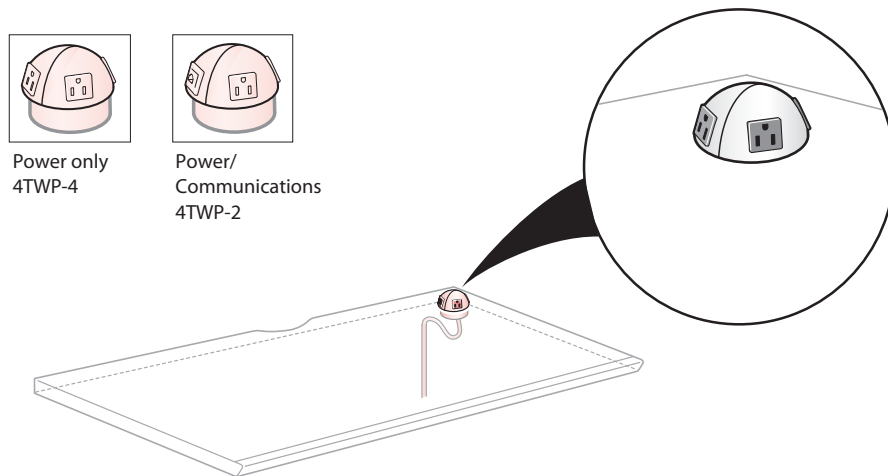

Flip Top Unit: Details

Flip Top Unit: Side Elevation

- Flip Top Unit: bezel and pop-up portion are proud to worksurface.
- When installed into a 1 3/8" (30mm) worksurface, the Flip Top Unit will extend below the worksurface.

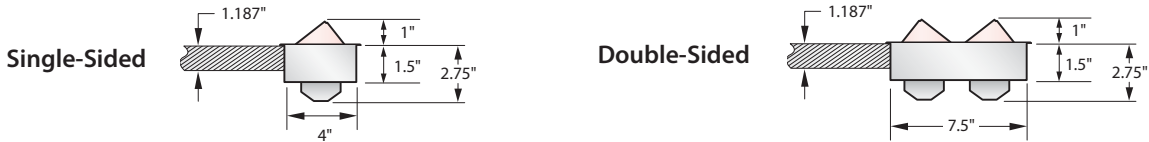

Flip Top Unit Bezel Dimensions:

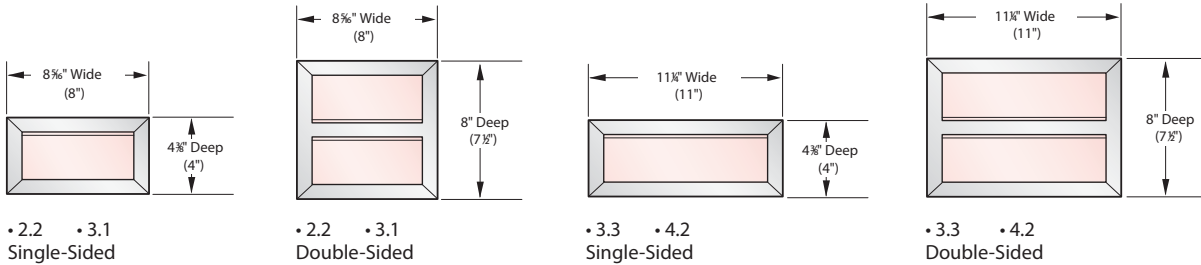

Note Cutout dimensions are in parentheses ().

The Flip Top Unit includes multiple data jack adapters to accommodate most field supplied data jacks. Also included are blank data covers to be used if no data access is needed. Data jacks are field supplied.

- 15 Amp rated simplex power receptacles
- Data information access ports

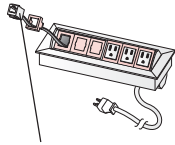

Data jack adapters standard in white; included with Flip Top Unit. (See manufacturer list for field supplied data jacks).

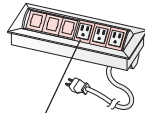

Perimeter edge of power receptacles and data ports faceplate standard in white.

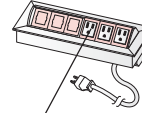

Simplex power receptacles standard in white; included with Flip Top Unit.

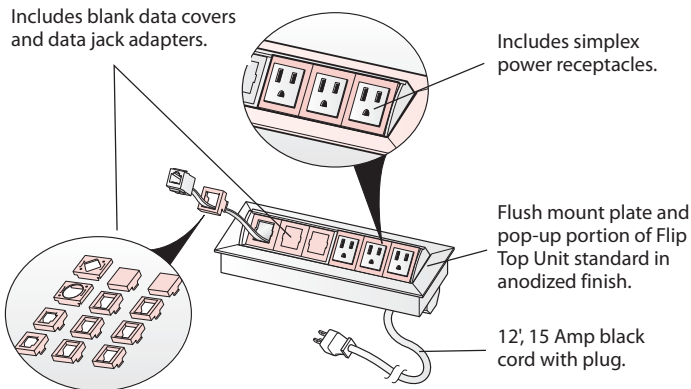

Data Jack Adapters Included

Manufacturer's List of Field Supplied Data Jacks

Systemax/CommScope
Tyco SL and 110 Connect Series Modular Jacks
Siemon Keystone Style
Allen Tel Versa Tap Series
Leviton Quick Port® Series
Nordx Keystone Style
Tyco SL Coupler Series
ADC (Krone) 6000 Series
Hubbell Xcelerator™ Keystone Series
Blank (no coupler/jack)
Ortonics TracJack Series
Panduit Mini-Com Series
Microphone Jack/3-Pin XLR (solder type only)
Video Monitor Jack/DB-15 (panel mount solder style)

Power Basics

3-Circuit

- As many as three separate 20 Amp rated circuits from one power feed module.
- 8-Wire system enclosed in one power distribution assembly:
 - 3 hot wires
 - 3 neutral wires
 - 1 common ground wire
 - 1 isolated ground wire
- Separate neutrals, one dedicated to each circuit, are capable of carrying computer-quality power.

4-Circuit

- As many as four 20-Amp rated circuits from one power feed module.
- 8-Wire system enclosed in one power distribution assembly:
 - 4 hot wires
 - 2 neutral wires
 - 1 common ground wire
 - 1 isolated ground wire
- 4-Circuit product is available in either a 2+2 configuration or a 3+1 configuration. Both configurations utilize a shared neutral conductor for at least two circuits. All circuits have access to either common or isolated ground.

Hardwire

- Components available to meet Chicago and other similar hardwire configurations.
- Consists of infeeds, junction boxes, and mounting hardware.
- Field supplied wire and receptacles allow for a variety of applications for specific needs.

Panel Power Options:

- 3-Circuit and 4-Circuit: Panel options specified with 3- or 4-Circuit power include a power distribution assembly and a flex connector.
- New York City (NYC): The New York City option includes the same components as those listed above but are shipped separate from the panel and require field installation.
- New York Port Authority (NYPA): The New York Port Authority option includes a metal raceway cover and is available with or without the power components.
- Hardwire: The hardwire option includes raceway covers for receptacle access. Hardwire electrical raceway kits and receptacle covers must be separately specified. In addition, receptacles, conduit, wiring, and other associated components must be field supplied.

3- and 4-Circuit Overview

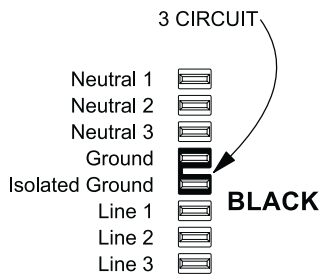

3-Circuit/Separate Neutrals

This option provides three circuits, each with its own neutral.

- Aligns with the 3 phase national power grid and most North American buildings.
- Is compatible with the following building power configurations:
 - 3 phase (208Y/120V)
 - Three wire single phase (120/240V)
 - Single phase (120V)
- Offers the most adaptability to special power needs such as:
 - multiple power sources
 - facility energy control
 - isolation of high harmonic loading
- Features receptacles with patented on-site circuit access programmability (available only on Power Base for furniture).
- Offers receptacles in common ground or isolated ground configurations.

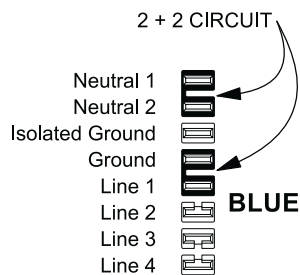

4-Circuit/2+2

This option provides four circuits, two circuits share neutral #1, two circuits share neutral #2.

- Provides more circuits (4 vs. 3) for each homerun from the electrical closet, which can reduce the installed cost per circuit.
- Is compatible with the following building power configurations:
 - 3 phase (208Y/120V)
 - Three wire single phase (120/240V)
- Is sometimes less adaptable to special power needs such as multiple power source or facility energy control.
 - Special power needs are typically planned in sets of two circuits
 - In some cases, 10 gauge shared neutral may not fully isolate circuits
- Modular receptacles have fixed circuit access.
- Offers receptacles in common ground or isolated ground configurations.

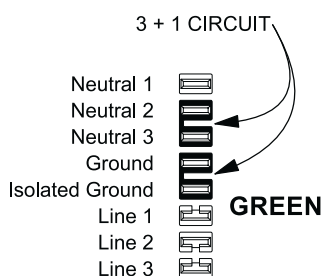

4-Circuit/3+1

This option provides 4 circuits, three circuits share neutral #1, circuit #4 has a separate neutral.

- Provides more circuits (4 vs. 3) for each homerun from the electrical closet, which can reduce the installed cost per circuit.
- Is compatible with the following building power configurations:
 - 3 phase (208Y/120V)
- Is sometimes less adaptable to special power needs such as multiple power source or facility energy control.
 - Special power needs are typically planned only using circuit #4
 - In some cases, 10 gauge shared neutral may not fully isolate circuits
- Modular receptacles have fixed circuit access.
- Offers receptacles in common ground or isolated ground configurations.

Power Planning General Guidelines and Checklist

All power application information is found in the corresponding component Price List, system-specific specification guide, and Power Base Planning Guide.

Verify the Following:

In: Routing power from the building into the furniture.

- Power feed length will reach building location.
- Infeed location is not occupied by a Receptacle.

Through: Routing power through the furniture.

- T-Leg or C-Leg table is equipped with a Modesty Panel/Power and Cable Management and power distribution assembly.
- Appropriate table-to-table power connector and J-Channel is specified when spanning power between powered tables.
- All adjacent tables have power, power connectors cannot be coupled together.

Out: Getting power out of the furniture so it can be used.

- Maximum receptacle quantity per infeed is not exceeded (13 US/10 Canada).
 - Fixed circuit receptacles are specified for all circuits.

General Power Application Guidelines:

- Do not mix 3-Circuit and 6-Circuit with 4-Circuit components.
- Do not mix 2+2 and 3+1 components.
- Components have unique polarity key and color coding (3-Circuit=black, 6-Circuit=ivory, 2+2=blue and 3+1=green).
- Circuit specific receptacles require some up-front planning for location and circuit identification.
- Local codes may dictate further restrictions and should be consulted.



This page intentionally left blank.

HAWORTH®

For more information call 800.344.2600 or 616.393.3000.

Haworth is a registered trademark of Haworth, Inc.
©Haworth, Inc. 2009 12.09

haworth.com | haworth-europe.com | haworth-asia.com