

Power Base AI

Application Guide

Table of Contents

Product Overview

Our Philosophy On Electrical	4
System Overview	5
Power Base AI Statement of Line.....	6
Power Base AI Components	8

Product Application

Idea Starters.....	13
Electrical Basics.....	19
3-Circuit Service Module Applications.....	22
3-Circuit Furniture Infeed Applications	23
4-Circuit Service Module Applications.....	24
4-Circuit Furniture Infeed Applications	25
Planning Guide.....	26
Planning for Power Base AI in Ten Steps.....	27

Technical Specifications	37
---------------------------------------	-----------

Power Base AI Three Part Specification Guide.....	39
--	-----------

Our Philosophy On Electrical

Haworth has a unique approach when it comes to Electrical Distribution and its ever changing layout. Our philosophy is to design and install for tomorrow rather than conventionally wiring for today. How do we do that? By running everything right beneath your feet using plug-and-play technology and a zone distribution methodology that delivers power to where the customer needs it. This ensures that your electrical infrastructure will be able to respond to today's fast pace and fast rate of change. Being flexible today is critical to tomorrow's survival.

Reconfiguring should be fast, growing should be easy, and with Haworth Power Base AI, it is. Our quick-connect systems power you up ...fast!

Haworth offers Power Base AI, a modular power system for raised floor applications, which helps to ensure quick installation and future flexibility. Quick installation reduces construction schedule risk and controls jobsite labor over runs. Future flexibility helps increase tenant satisfaction and lowers operating and renovation costs.

Haworth has developed two power distribution systems to accommodate the electrical needs of all major North American office furniture manufacturers: The 3-Circuit and the 4-Circuit systems. Each has been specifically designed for use in Haworth Access Flooring and is based on plug-and-play connectivity.

The 3-Circuit separate neutral system provides individual branch circuits for power quality and multiple power source flexibility not available in 4-Circuit applications. The 4-Circuit shared neutral version helps to maximize the number of circuits while staying within the common 1/2" trade conduits. This modular power system is UL Listed, CSA Certified, and complies with NEC Article 604.

The Power Base AI system consists of six main elements to distribute power. They include the following:

- Zone Distribution Box
- Jumper
- Splitter
- Service Module
- Modular Receptacle
- Haworth Plug-and-Play Furniture Base Feed

Above Ceiling Application

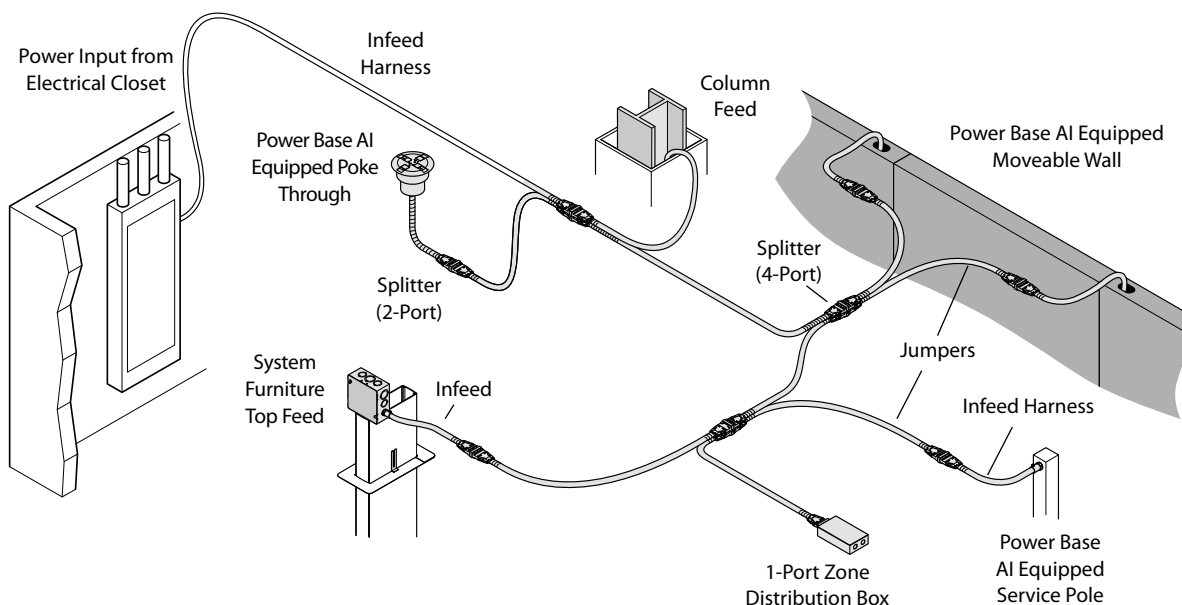

System Overview

Power is typically routed from the electrical closet through pre-wired flexible conduit to separate zones of the floor plate. Power is then distributed within each zone using modular wiring. Modular wiring puts flexibility out in the area where most day-to-day reconfigurations occur. Power can be routed from the electrical closet with the pre-wired Zone Distribution Box or an Infeed Harness. The Zone Distribution Box is available with factory installed pre-wired conduits with three sets up to 125', and two sets of circuits up to 200', or the field wired Zone Distribution Box can be used with locally supplied MC cable or conduit. The in-feed harness routes a single set of circuits and is available in lengths up to 100'. Power is routed within the zone by 8-Wire modular flex conduit Jumpers. The Jumpers are fully populated with all eight wires so all circuits are available for future moves. The Flush Service Module provides Modular Receptacles under a hinged lid. The Modular Receptacles allow fast change of circuits as users' needs change. Flush Service Modules can be moved to other floor tile locations by re-routing the flex conduit Jumpers. The Service Modules allow for multiple Jumpers to connect (two Dual Service Modules/four Quad Service Modules) for branching within a zone. The Splitter is used to join up to four Jumpers. By using Splitters, the zone can be expanded to meet future needs. For more extensive renovations, the Zone Distribution Box can be moved by re-routing the flex conduit feed.

Under Floor Application

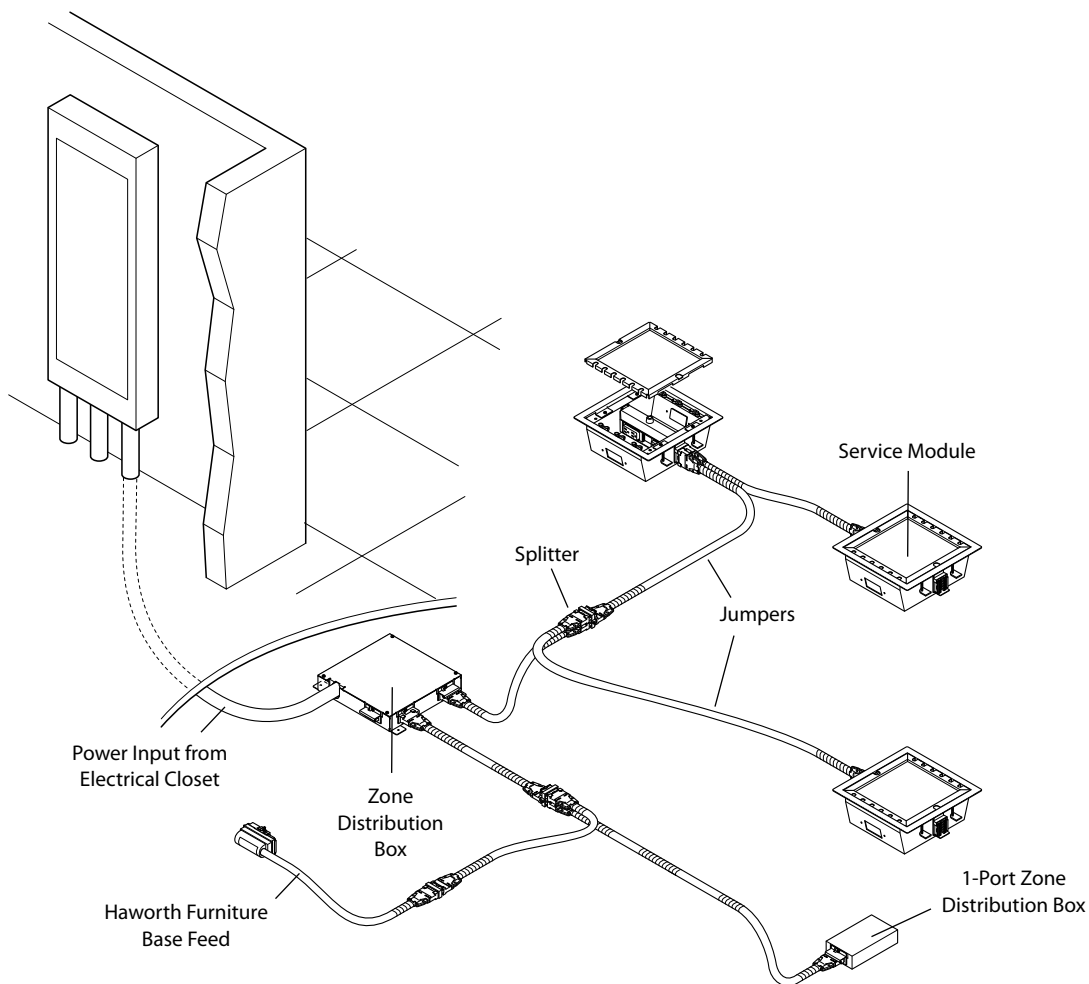

Note MC Cable = Metal Clad Cable in this document.

Power Base AI Statement of Line

3- and 4-Circuit

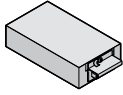

Field-Wired 1-Port
Zone Distribution Box

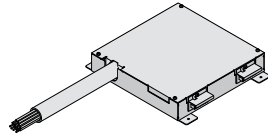

Pre-Wired 2-Port
Zone Distribution Box

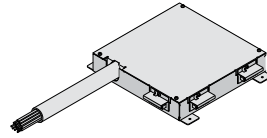

Pre-Wired 3-Port
Zone Distribution Box

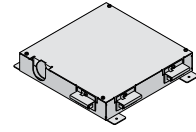

Field-Wired 3-Port
Zone Distribution Box

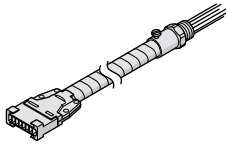

Infeed Harness
15', 10', 25', 50', 75', or 100' Long

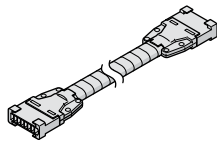

Jumper
5', 10', 15', 20', 35', or 50' Long

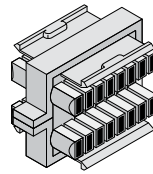

4-Port Splitter

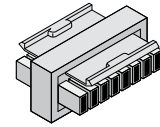

2-Port Splitter

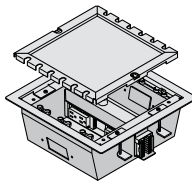

Quad Service Module

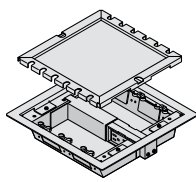

Dual Service Module

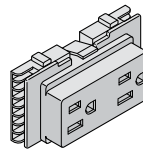

Modular Receptacle
(15 Amp Duplex)

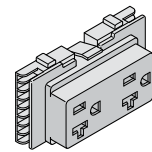

Modular Receptacle
(20 Amp Duplex)

Hardwire

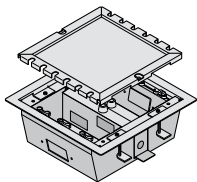

Quad Service Module
(Field-Wired)

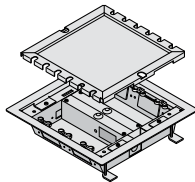

Dual Service Module
(Field-Wired)

Power Base AI Statement of Line

Accessories

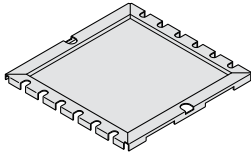

Service Module Lid

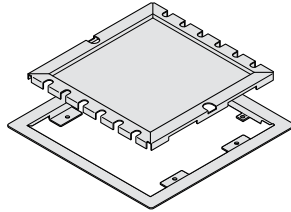

Service Module Lid and Trim Ring

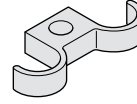

Cord Manager Loop

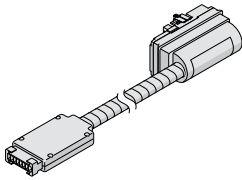

PREMISE®, Moxie®, and Compose™
Floor Infeed

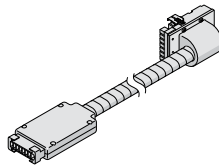

PLACES®, UniGroup®, and Tactics®
Floor Infeed

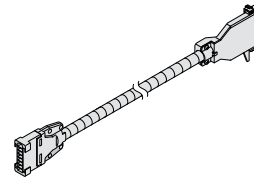

Floor Infeed

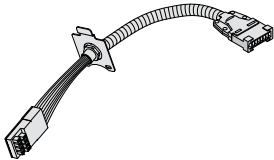

RACE® Single Harness Connector

Power Base AI Components

Infeed Harness

The Infeed Harnesses are used to convert between "hardwiring" and "modular wiring". Supports plug-and-play power distribution within each power zone. Longer lengths can be used from the electrical closet to start a power zone. Shorter lengths can be used to transition to products without a modular connector. Quick connect male modular power connector allows fast install. Can be connected directly to a Service Module. Use a circuit distributor to connect to Jumpers or systems furniture base feed. Available in lengths up to 100' with either 3- or 4-Circuit configurations.

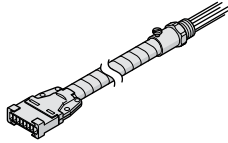

Infeed Harness

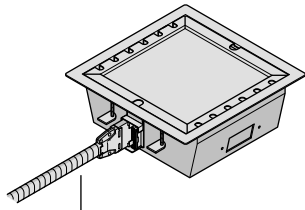

Infeed Harness

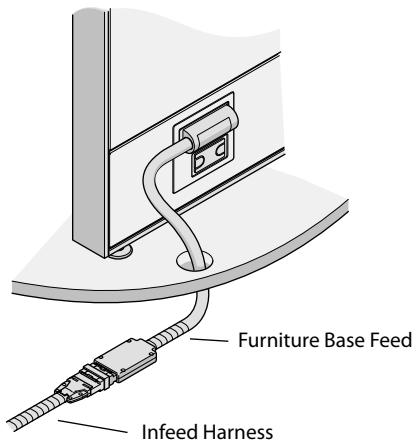

Furniture Base Feed

Infeed Harness

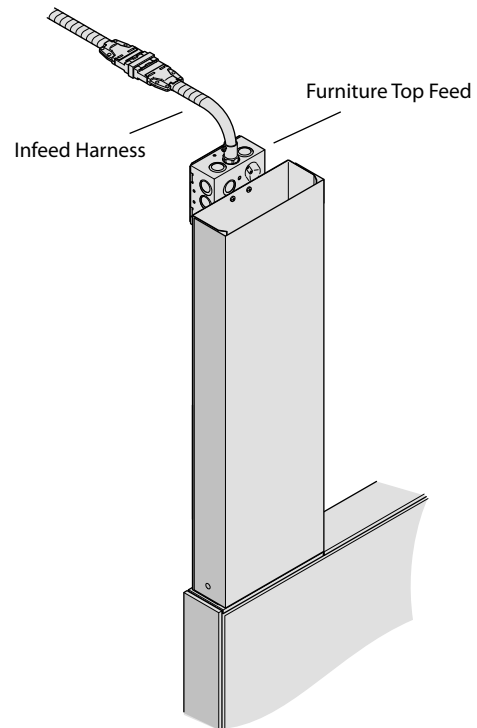

Furniture Top Feed

Infeed Harness

Power Base AI Components

1-Port Zone Distribution Boxes

The 1-Port Zone Distribution Box is used to convert between "hardwiring" and "modular wiring". Supports plug-and-play power distribution within each power zone. Can be used with MC cable or conduit from the electrical closet to begin a power zone. Can be used to connect furniture or wall feed conduit to modular power connection. Quick connect female modular power connector allows fast install. Can be connected directly to a Jumper or Infeed Harness.

- Available in either 3- or 4-Circuit configurations.

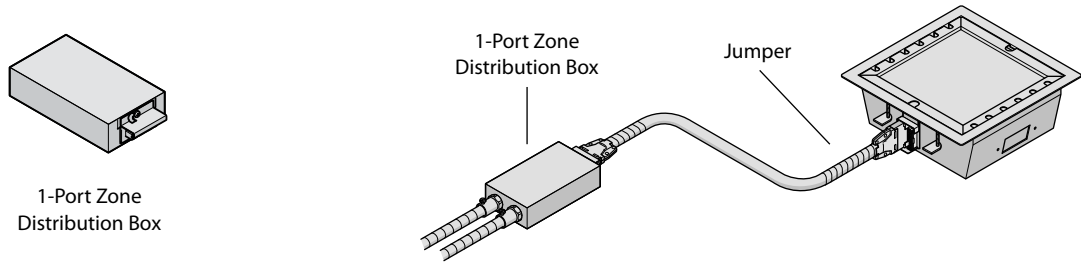

Zone Distribution Boxes

The Zone Distribution Box is used to convert between "hardwiring" and "modular wiring". Supports plug-and-play power distribution within each power zone. The pre-wired 3-Port Zone Distribution Box routes three sets of circuits through 1¼" flex conduit. Each set of circuits is connected to one female connector mounted to the box. The pre-wired 2-Port Zone Distribution Box routes two sets of circuits through 1¼" flex conduit. The field wired Zone Distribution Box has three sets of female connectors which can be hardwired to field installed wiring. Can be connected directly to a Jumper or a furniture base feed. Available pre-wired with 10 AWG wire in lengths up to 125' or 8 AWG wire up to 200' with sets of either 3- or 4-Circuits.

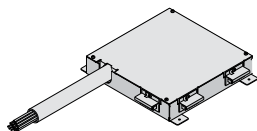

Pre-Wired 3-Port Zone Distribution Box

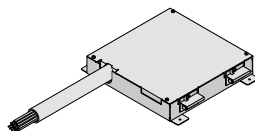

Pre-Wired 2-Port Zone Distribution Box

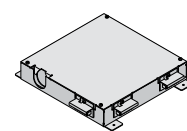

Field Wired 3-Port Distribution Box

Power Base AI Components

Jumpers

Jumpers are used to interconnect modular power components within each power zone. Supports plug-and-play power distribution within each power zone. Flexible conduit construction with quick connect modular power connector heads allows quick installation and easy reconfiguration. Available in either 3- or 4-Circuit configurations.

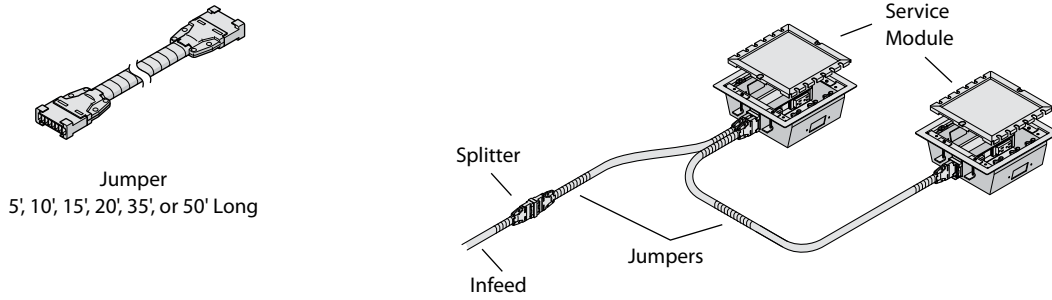

Note The Jumper has male connectors. A circuit distributor (female connectors) is required to connect Jumpers to another Jumper. A circuit distributor can join up to four Jumpers.

Splitters

Splitters allow interconnection of up to four Jumpers within each power zone. Supports plug-and-play power distribution within each power zone. Quick connect modular power connection allows quick installation and easy reconfiguration. The Splitter has four female connectors. One port is intended for the supply connection with the ability to distribute out to the other port(s). Available in either 2-Port or 4-Port configuration with 3-Circuit or 4-Circuit 8-Wire configurations.

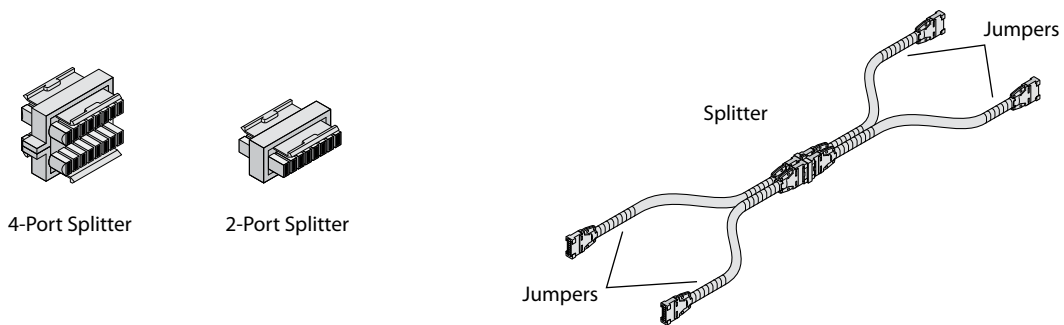

Note A Jumper (female connectors) is required to connect another Splitter or Zone Distribution Box.

Power Base AI Components

Service Modules

Service Modules are used to provide power and/or data outlets at floor level. Modular Receptacles are located under a hinged lid which is flush with the finished floor. Supports plug-and-play power distribution within each power zone. Quick connect modular power connector allows fast install and easy reconfiguration of Jumpers and Receptacles. The Service Modules have Modular Receptacles to allow fast change of circuit access. The Quad Service Module has connector ports for four Jumpers and four Receptacles for use on 4.5" or higher finished floor heights. The Dual Service Module has female connector ports for two Jumpers and two Receptacles for use on 2.5" or higher finished floor heights. Quad Service Module provided with two data openings (2.71" x 1.38") for furniture info plates; Dual Service Module has four furniture info plate openings. Data opening has knockout for mounting single gang data plates. Service Modules are available in either 3- or 4-Circuit configurations.

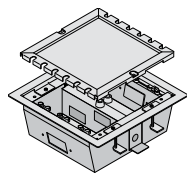

Quad Service Module (Field Wired)

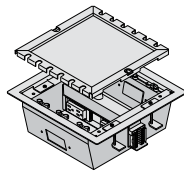

Quad Service Module Modular

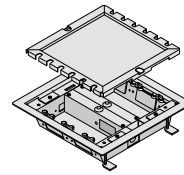

Dual Service Module (Field Wired)

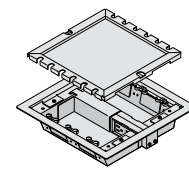

Dual Service Module Modular

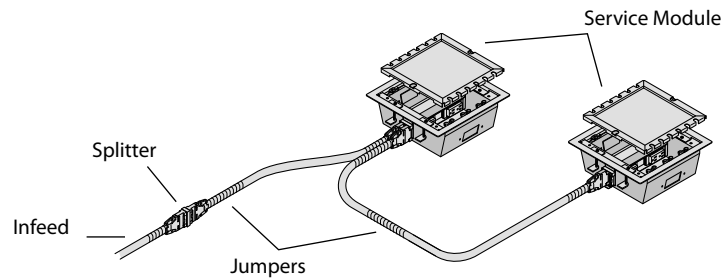

Modular Receptacles

The Modular Duplex Receptacles are used to access specific circuits of the Service Module. Supports plug-and-play power distribution within each power zone. Quick connect modular power connector allows fast install into Service Modules for easy reconfiguration. Available in 15 amp or 20 amp outlet reconfiguration, common ground, or isolated ground access; all with either 3- or 4-Circuit configurations.

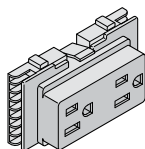

Modular Receptacle (15 Amp Duplex)

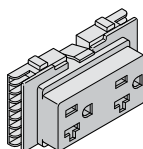

Modular Receptacle (20 Amp Duplex)

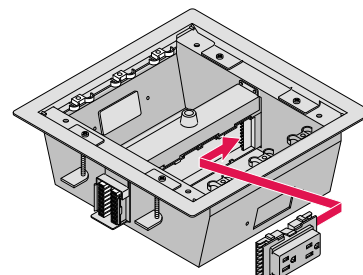

Power Base AI Components

Furniture Base Feeds

Haworth exclusive base feeds integrate Power Base AI in the floor with modular power for Haworth systems furniture. Base feed has modular power connector which mates to underfloor components. Powering up Haworth furniture is a click away.

Male connector head must be fed by female connector of Splitter, Service Module, or Zone Distribution Box. Male connector will not connect directly to male connector of the Jumper or Infeed Harness.

Base feeds are available for Haworth furniture. Please refer to appropriate Price List for current specification information.

PREMISE/Compose Floor Infeed

- PREMISE Price List
- Compose Price List

PLACES Floor Infeed

- UniGroup Too and Tables Price List

RACE

- RACE Price List

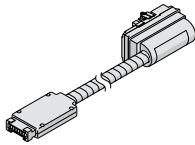

PREMISE®, Moxie®, and Compose™ Floor Infeed

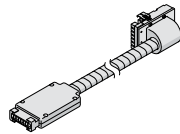

PLACES®, UniGroup®, and Tactics® Floor Infeed

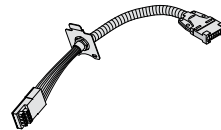

RACE® Single Harness Connector

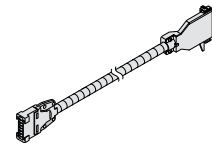

Floor Infeed

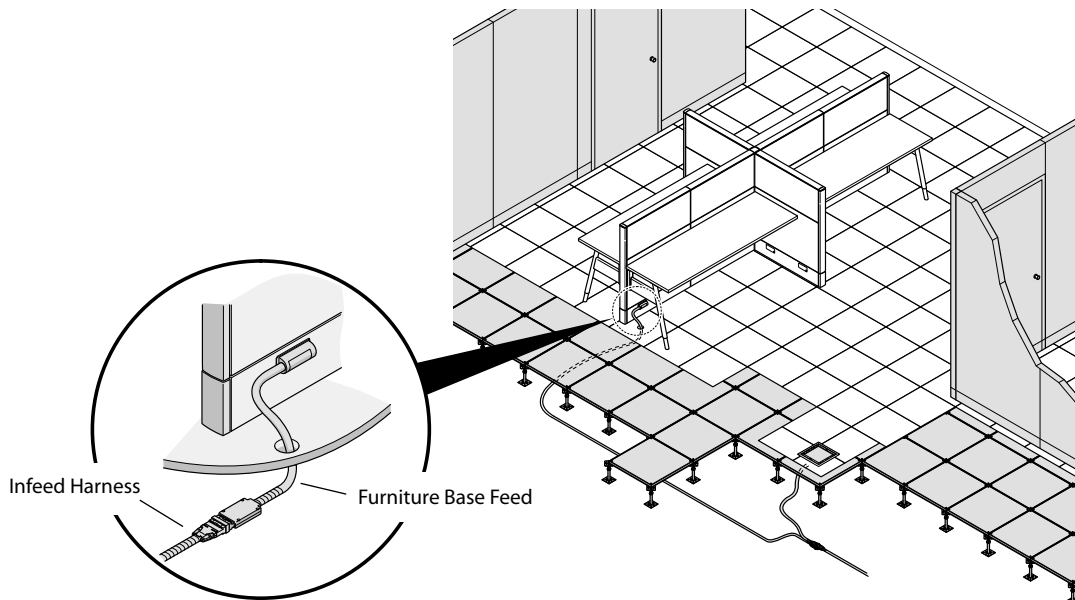

Idea Starters

The following sample applications show how Power Base AI components can be configured to deliver power to several workstations using either powered systems furniture or non-powered furniture.

Idea Starter A

Four station cluster using 1-Port Zone Distribution Box and Service Modules. This method of delivering power to the work stations is used when the furniture does not have power distribution capability.

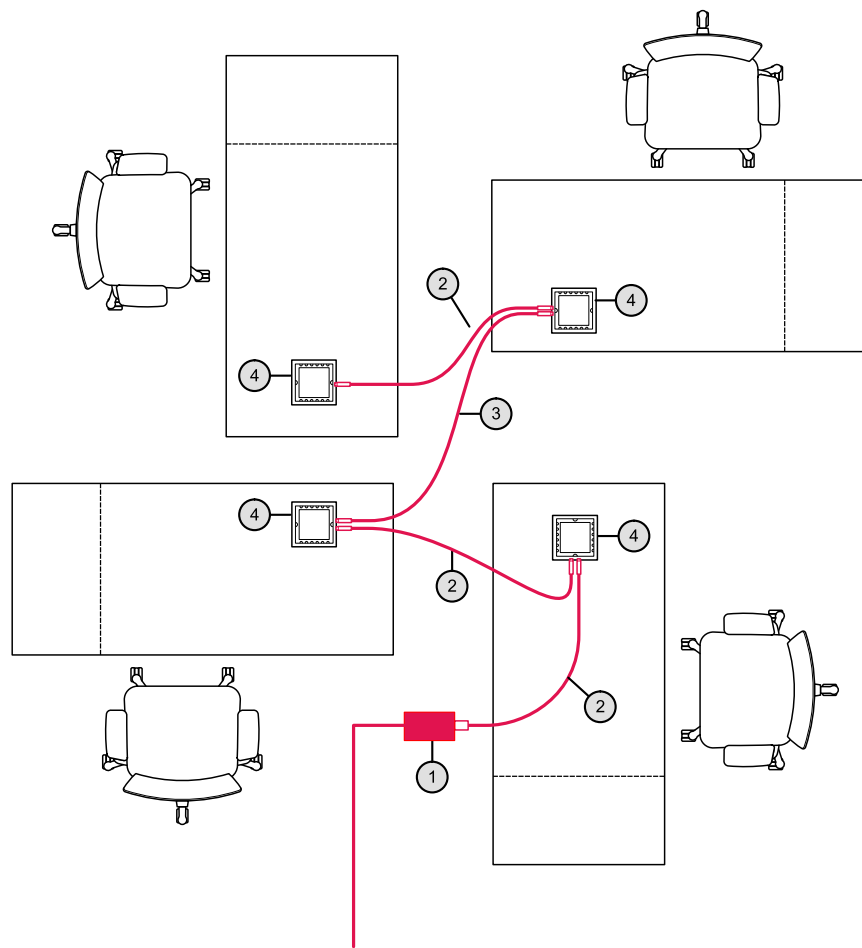

Homerun Cable Back to Electrical Panel

Product Number	Product Description	Quantity
① FBEZ-2000-31	1-Port Zone Distribution Box	1
② FBEJ-0005-3W	5' Jumper	3
③ FBEJ-0010-3W	10' Jumper	1
④ FBEP-0000-32	Dual Flush Service Module	4
FBER-0015-31G*	Receptacle (15 amp; Circuit Common Ground)	3
FBER-0015-32G*	Receptacle (15 amp; Circuit Common Ground)	3
FBER-0015-33G*	Receptacle (15 amp; Circuit Common Ground)	2

*Not shown on illustration, but must be specified along with the Service Module.

Idea Starters

Idea Starter B

Four station cluster with powered systems furniture. Two four station clusters may be supplied by an Infeed Harness and 4-Port Splitter depending on amperage load per station.

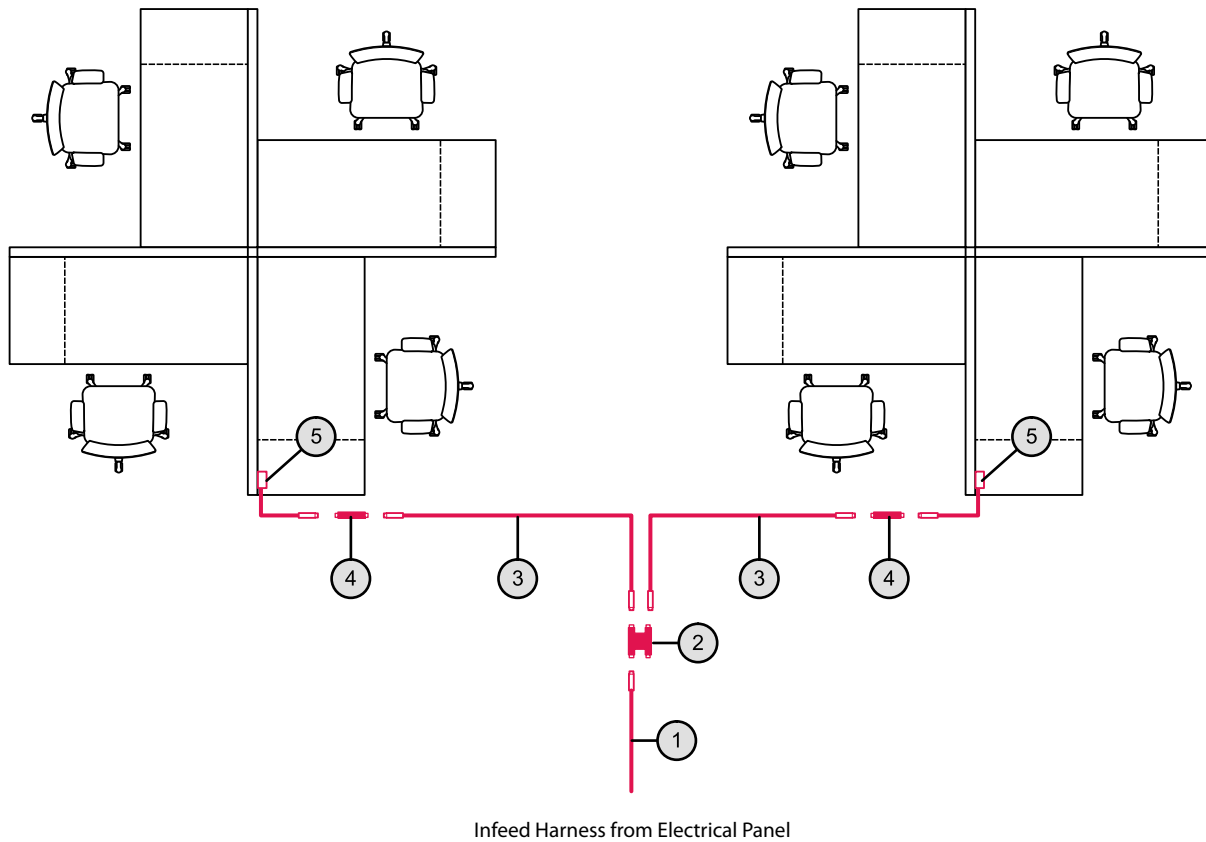

Product Number	Product Description	Quantity
① FBEH-0050-3W	Infeed Harness: 50'	1
② FBED-0000-34	4-Port Splitter	1
③ FBEJ-0010-3W	10' Jumper	2
④ FBED-0000-32	2-Port Splitter	2
⑤ ENEJ-0048-3WF	PREMISE System Floor Infeed	2

Idea Starters

Idea Starter C

Six station cluster with 3-Port Zone Distribution Box and floor-mounted Service Modules. Use when the furniture does not have power distribution capability.

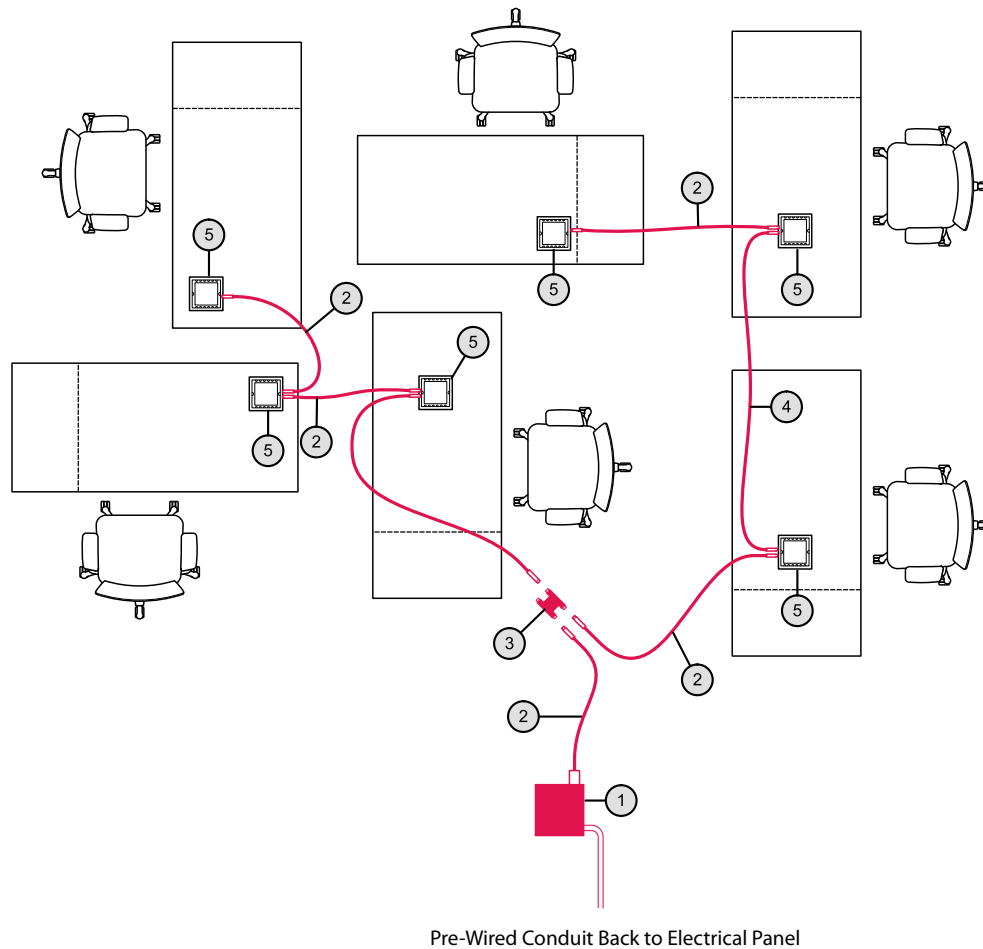

Product Number	Product Description	Quantity
① FBEZ-3050-33	3-Port Zone Distribution Box (50' pre-wired Conduit)	1
② FBEJ-0005-3W	5' Jumper	6
③ FBED-0000-34	4-Port Splitter	1
④ FBEJ-0010-3W	10' Jumper	1
⑤ FBEF-0000-32	Dual Flush Service Module	6
FBER-0015-31G*	Receptacle (15 amp; Circuit Common Ground)	4
FBER-0015-32G*	Receptacle (15 amp; Circuit Common Ground)	4
FBER-0015-33G*	Receptacle (15 amp; Circuit Common Ground)	4

*Not shown on illustration, but must be specified along with the Service Module.

Idea Starters

Idea Starter D

Splitters can be used in mixed applications. This example shows a 4-Port Splitter feeding a Furniture Base Feed and two Flush Service Modules.

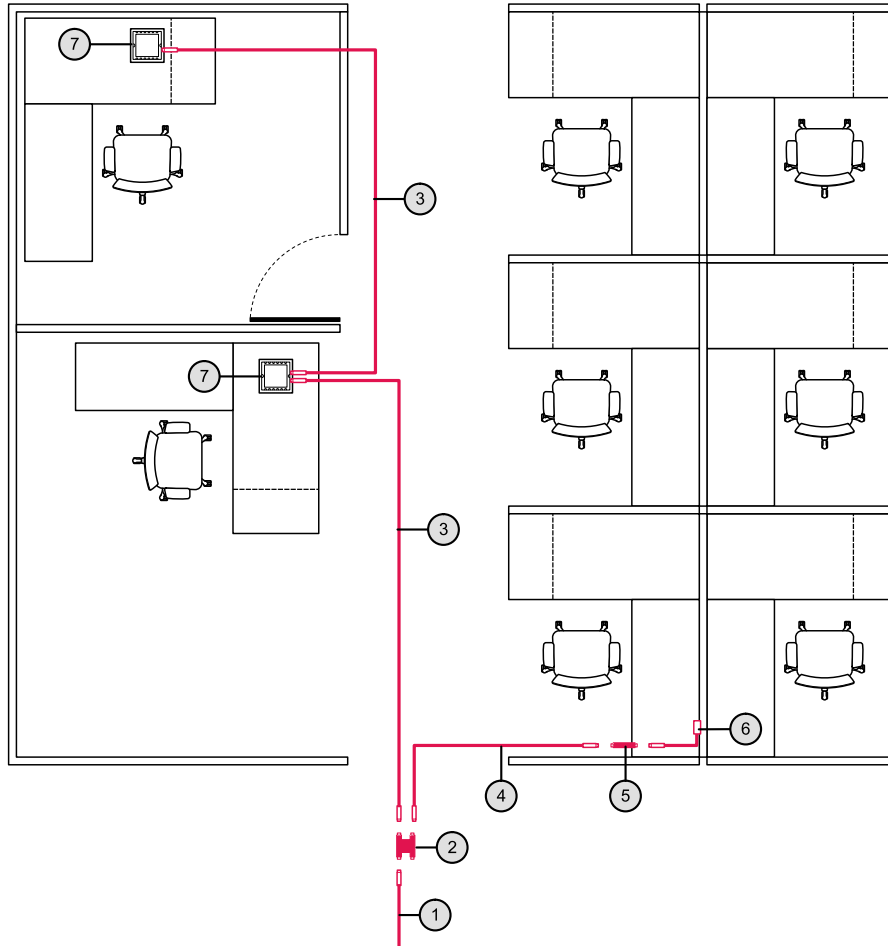

Infeed Harness from Electrical Panel

Product Number	Product Description	Quantity
① FBEH-0050-3W	Infeed Harness (50')	1
② FBED-0000-34	4-Port Splitter	1
③ FBEJ-0015-3W	15' Jumper	2
④ FBEJ-0010-3W	10' Jumper	1
⑤ FBED-0000-32	2-Port Splitter	1
⑥ ENEJ-0048-3WF	PREMISE System Floor Infeed	1
⑦ FBEF-0000-32	Dual Flush Service Module	2
FBER-0015-31G*	Receptacle (15 amp; Circuit Common Ground)	2
FBER-0015-32G*	Receptacle (15 amp; Circuit Common Ground)	1
FBER-0015-33G*	Receptacle (15 amp; Circuit Common Ground)	1

*Not shown on illustration, but must be specified along with the Service Modue.

Idea Starters

Idea Starter E

LifeSPACE® panel with Level 4 quick connect electrical or Enclose® panel with Level 4 power. Using Power Base AI with LifeSPACE allows for maximum flexibility in reconfiguration of office space. For reconfiguration requiring minimal displacement of the LifeSPACE panel, simply move the panel to the new location, if the Jumper length allows. Or when reconfiguration requires a new layout, simply disconnect the Jumper from the LifeSPACE panel and the Zone Distribution Box. Move the LifeSPACE panel to the new location and reconnect Jumper to the LifeSPACE panel and the Zone Distribution Box. Quick and easy with little or no mess. If using LifeSPACE electrical panels and Power Base AI, the systems must be coordinated.

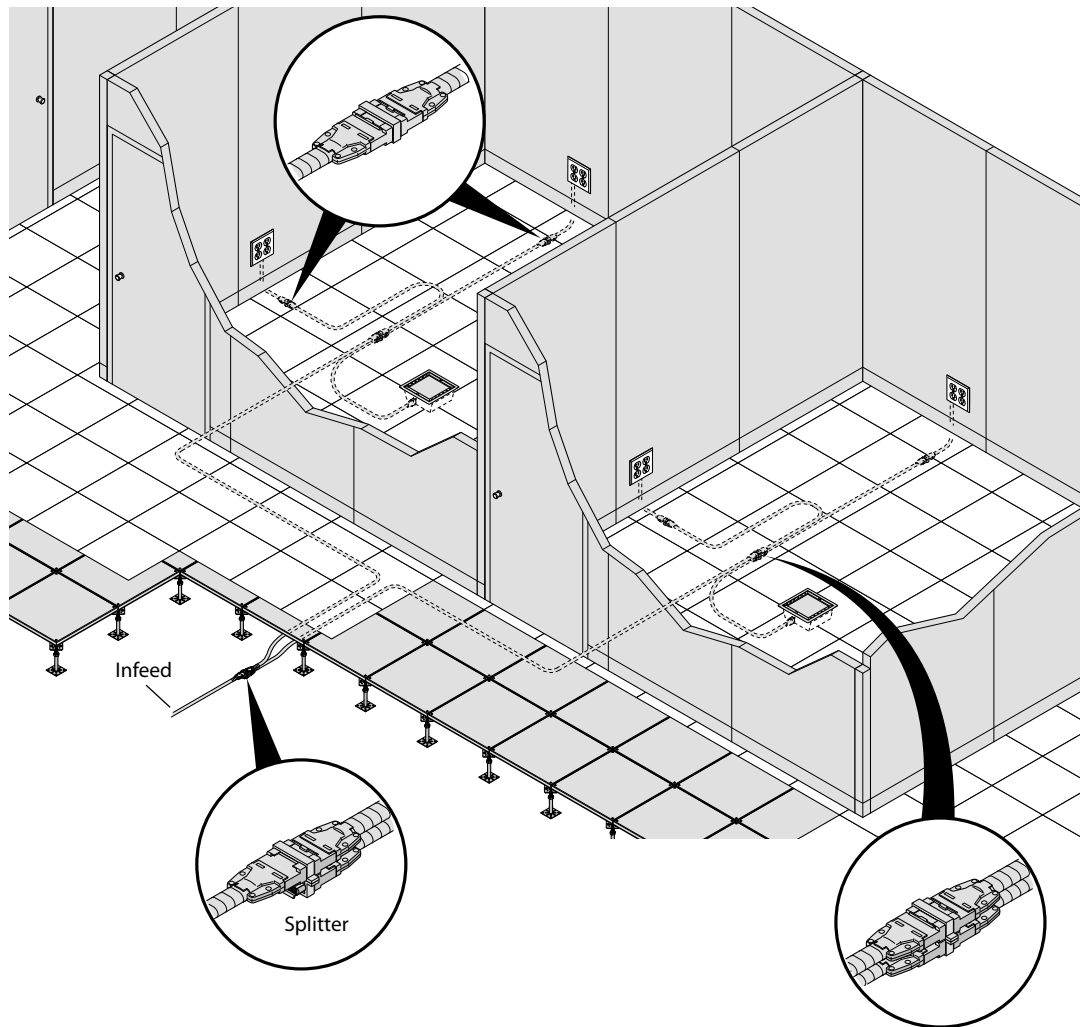

Note All GFI Outlets must be hardwired.

Idea Starters

Idea Starter F

When providing power to non-Haworth furniture or LifeSPACE walls with Level 2 or Level 3 electrical, use a 1-Port Zone Distribution Box for a hardwire transition.

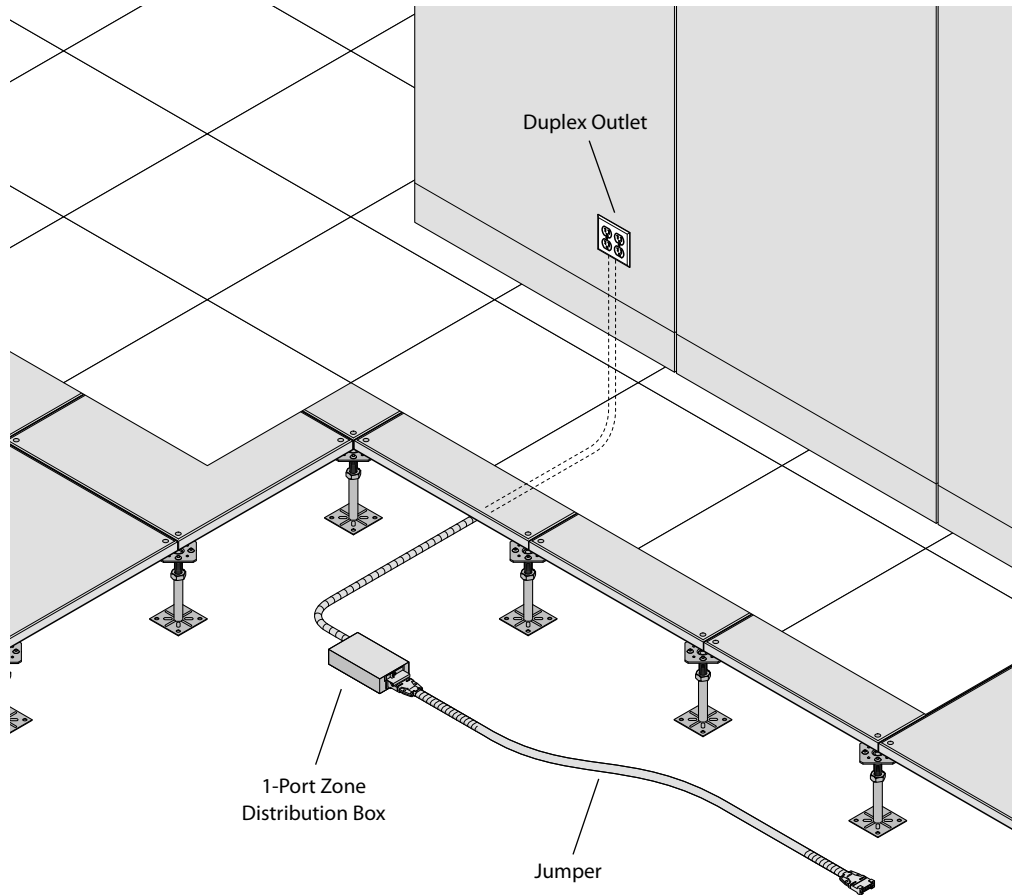

Electrical Basics

There are two electrical systems prevalent in North America — 3-Circuit or 4-Circuit. The choice to specify 3- or 4-Circuit power is determined both by the system furniture requirements and the power provided by the building. Check with the project electrical engineer on what system is most suitable prior to specifying the electrical system for a project.

Idea Starter A

An 8-Wire 3-Circuit system consists of three line conductors, three neutral conductors, and two ground conductors. Haworth Systems Furniture usually uses the 3-Circuit configuration. This configuration utilizes independent neutral conductors for each line conductors, creating individual branch circuits. These individual branch circuits provide the most flexibility in support of building wiring configurations and the highest level of power quality.

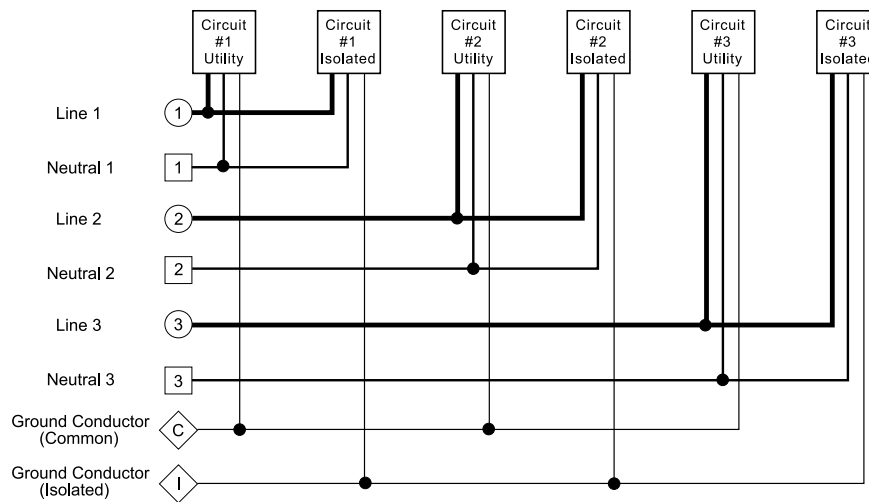

Benefits of Using a 3-Circuit System

1. Individual branch circuits allow electrician to adapt wiring configuration as users' needs change.
2. Can be connected to multiple power sources.
3. Common and Isolated ground available on all 3-Circuits.
4. Independent neutrals confine power quality issues to an individual branch circuit.
5. Haworth Systems Furniture Base Feed plugs directly into 3-Circuit Power Base AI — eliminates labor to wire base feed via a junction box.
6. May be more cost effective depending on client's needs.

Disadvantages of Using a 3-Circuit System

1. Less circuit capability per zone.
2. More Power Base AI components and homerun cables may be required.
3. May require more on site installation labor required from Electrical Contractor.
4. May not match configuration used by most System Furniture Manufacturers.

Electrical Basics

4-Circuit System

An 8-Wire 4-Circuit system consists of four line conductors, two neutral conductors, and two ground conductors. Within this system, two wiring configurations are available: 2+2 and 3+1. In a 2+2 configuration, two line conductors share one neutral conductor and one ground wire and the other two line conductors share a neutral conductor and ground wire. In a 3+1 configuration, three line conductors share one neutral conductor and one ground wire and the other line conductor uses the other neutral conductor and ground wire. These systems utilize a shared, oversized neutral conductor to minimize adverse effects caused by harmonic currents.

2+2

The 2+2 configuration includes two lines on one oversized neutral and two lines on another oversized neutral. Specify this configuration where multiple dedicated or isolated ground circuits are required in a zone or more than one source of power, such as UPS power, is required.

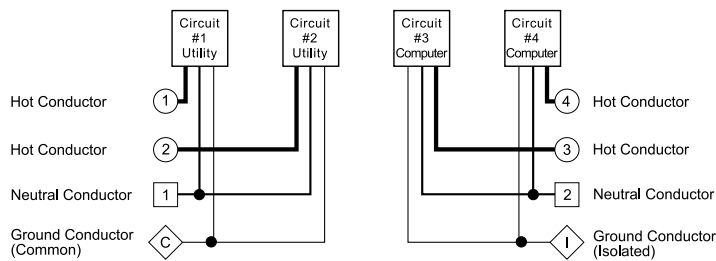

3+1

The 3+1 configuration comes with three lines on one oversized neutral and one line on a separate oversized neutral. Specify this configuration where either no dedicated or isolated ground is required or only one circuit will be used as a dedicated or isolated ground.

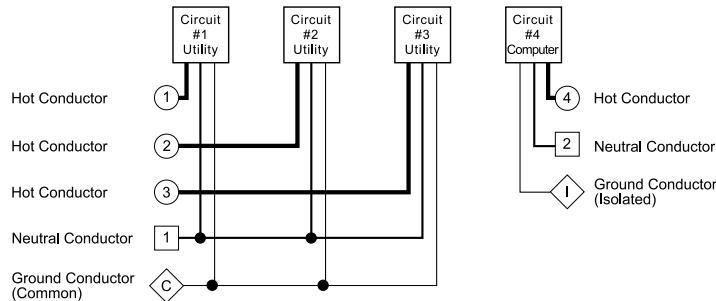

Benefits of Using a 4-Circuit System

1. More circuit capability per zone.
2. Fewer Power Base AI components and homerun cables may be required.
3. Usually less on site installation labor required from Electrical Contractor.
4. May match configurations used by most System Furniture Manufacturers.

Disadvantages of Using a 4-Circuit System

1. Harder to adapt to changes in building wiring needs.
2. Limited capacity of isolated ground circuits.
3. Shared neutral may cause sharing of power quality problems.
4. GFCI (Ground Fault Circuit Interrupter) may not be available.

Electrical Basics

Electrical Code and Performance Factors

National and local electrical codes may restrict what you can do with these products. These codes are primarily designed for safety. To achieve the desired level of flexibility and performance for a facility, additional factors may need to be considered. Below is a brief description of safety and performance topics. To ensure safety and code compliance, be sure that your plans are reviewed by an expert in local code requirements such as an electrical engineer or electrical contractor. The person or group planning and supervising installation of electrical components is responsible for complying with all applicable national and local electrical codes. Within local code guidelines, limit the receptacle installation to the maximum necessary to power the equipment in the current work station plan. Avoid providing receptacles for projected needs, because surplus receptacle availability may encourage use of unauthorized equipment and lead to electrical overloads.

Circuit Capabilities and Code Restrictions

Each circuit in the Power Base AI modular electrical system carries a maximum load of 20 amps (15 amps in Canada) of electrical service. However, applicable national and local codes may further restrict the current usage of the power distribution system. For example, the National Electrical Code (NEC) dictates a load requirement of no more than 80% (16 amps) capacity for continuous load situations (constant use of a circuit for three or more hours). Examples of continuous use loading include circuits that supply lighting, computers, and printers with power throughout the day. In practice, most circuits are subjected to continuous load.

Planning for the Future

Based on the circuit load capacity of 16 usable amps (U.S.) per continuous-use circuit, Haworth recommends that the initial loading on each circuit be approximately 12 amps. This initial planning limitation permits the user to add or change electrical equipment within the guidelines of local amperage limits. If you immediately allow maximum amperage loading of 16 amps (U.S.) on each circuit, you will restrict the future addition of equipment and may force a redesign of the electrical layout.

Voltage Drop

The natural resistance of the wires causes voltage to fall away from the ideal voltage (120V in North America). The farther your circuit travels from the electrical closet, the more voltage drop will occur. The NEC requires that voltage drop be no more than 5% from the ideal voltage. To limit how far the systems falls below the ideal voltage, limit the length of the circuits to less than 80' from a Zone Distribution Box.

Number of Receptacles

The NEC also restricts the number of receptacles on a 20 amp rated circuit to 13 (10 in Canada). These are maximum limits only and not recommendations. Local codes may restrict number of receptacles. Within local code guidelines, limit the receptacle installation to the maximum necessary to power the equipment in the current work station plan. Avoid providing receptacles for projected needs, because surplus receptacle availability may encourage use of unauthorized equipment and lead to electrical overloads.

REGARD LOCAL CODES CAREFULLY

Local codes supercede national codes. Local codes may restrict electrical plans more than national codes. For example, a local code may not allow any modular underfloor power system. Local codes may also limit the number of jumper cables and receptacles that may be used.

3-Circuit Service Module Applications

Note Examples are based on planning for an initial load of 12 amps per circuit. Check local electrical codes for maximum allowed electrical devices per circuit.

3-Circuit Service Module: Application 1

Electrical Load:

- 2 floor boxes per feed
- 18 amps per office
(leaves 6 amps per office for future growth)

Requires:

- 1 Infeed Harness
- 1 Jumper
- 2 Service Modules



3-Circuit Service Module: Application 2

Electrical Load:

- 6 floor boxes per feed
- 6 amps per office
(leaves 2 amps per office for future growth)

Requires:

- 1 Infeed Harness
- 6 Jumpers
- 1 Splitter
- 6 Service Modules

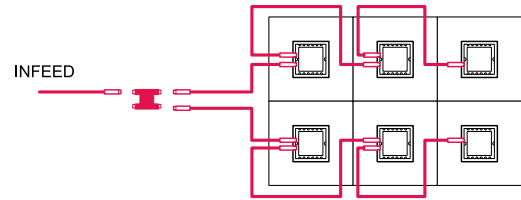

3-Circuit Service Module: Application 3

Electrical Load:

- 18 floor boxes per feed
- 2 amps per office
(leaves 0.6 amps per office for future growth;
maximize size of floor box zone even if a
lower amps per office is desired)

Requires:

- 1 Infeed Harness
- 18 Jumpers
- 1 Splitter
- 18 Service Modules

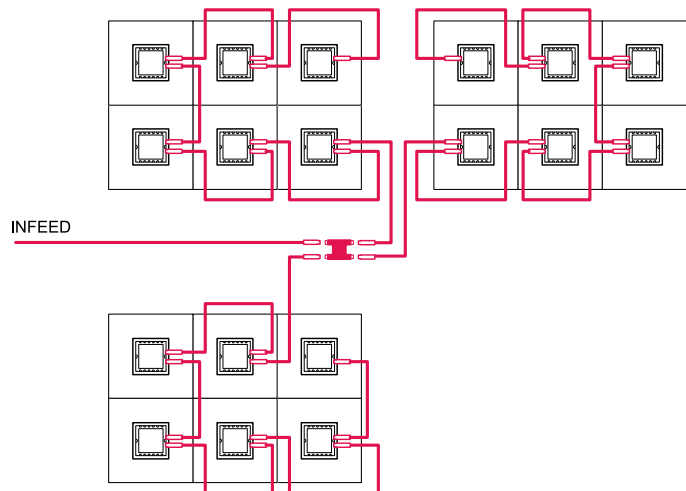

3-Circuit Furniture Infeed Applications

Note Examples are based on planning for an initial load of 12 amps per circuit. Check local electrical codes for maximum allowed electrical devices per circuit.

3-Circuit Furniture Infeed: Application 1

Electrical Load:

- 3 offices per feed
- 12 amps per office
(leaves 4 amps per office for future growth)

Requires:

- 1 Zone Distribution Box
- 2 Jumpers
- 2 Splitters
- 2 Furniture Infeeds

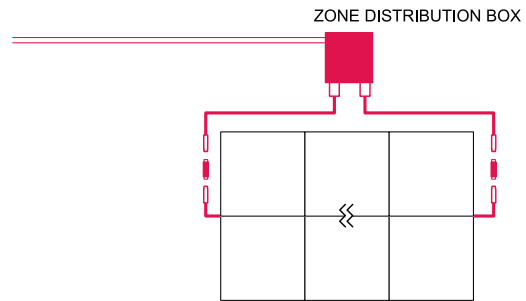

3-Circuit Furniture Infeed: Application 2

Electrical Load:

- 6 offices per feed
- 6 amps per office
(leaves 2 amps per office for future growth)

Requires:

- 1 Infeed Harness
- 1 Splitter
- 1 Furniture Infeed

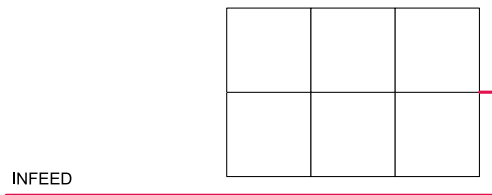

3-Circuit Furniture Infeed: Application 3

Electrical Load:

- 18 offices per feed
- 2 amps per office
(leaves 0.6 amps per office for future growth)

Requires:

- 1 Infeed Harness
- 3 Jumpers
- 4 Splitters
- 3 Furniture Base Feeds

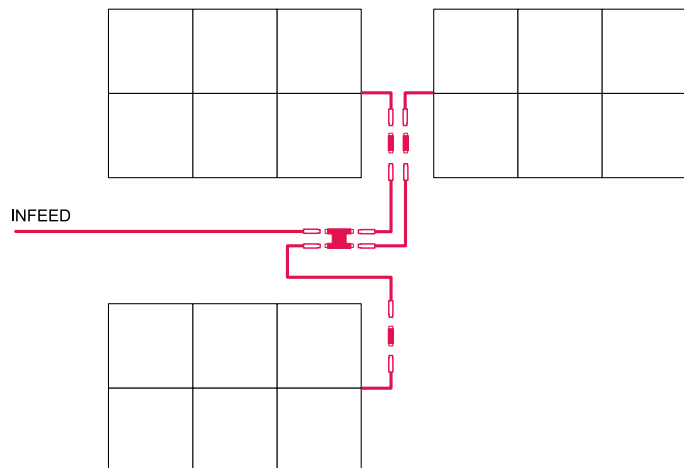

4-Circuit Service Module Applications

Note A Jumper (male connectors) is required to connect to another Splitter or Zone Distribution Box.

4-Circuit Service Module: Application 1

Electrical Load:

- 3 floor boxes per feed
- 16 amps per office
(leaves 5.3 amps per office for future growth)

Requires:

- 1 Infeed Harness
- 2 Jumpers
- 3 Service Modules

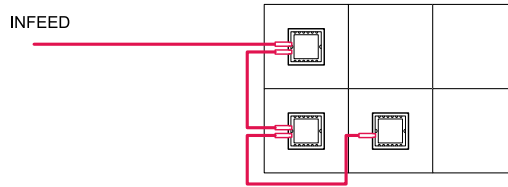

4-Circuit Service Module: Application 2

Electrical Load:

- 6 floor boxes per feed
- 8 amps per office
(leaves 2.6 amps per office for future growth)

Requires:

- 1 Infeed Harness
- 6 Jumpers
- 1 Splitter
- 6 Service Modules

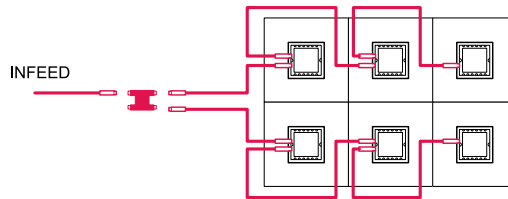

4-Circuit Service Module: Application 3

Electrical Load:

- 24 floor boxes per feed
- 2 amps per office
(leaves 0.6 amps per office for future growth;
maximize size of floor box zone even if a
lower amps per office is desired)

Requires:

- 1 Infeed Harness
- 26 Jumpers
- 3 Splitters
- 24 Service Modules

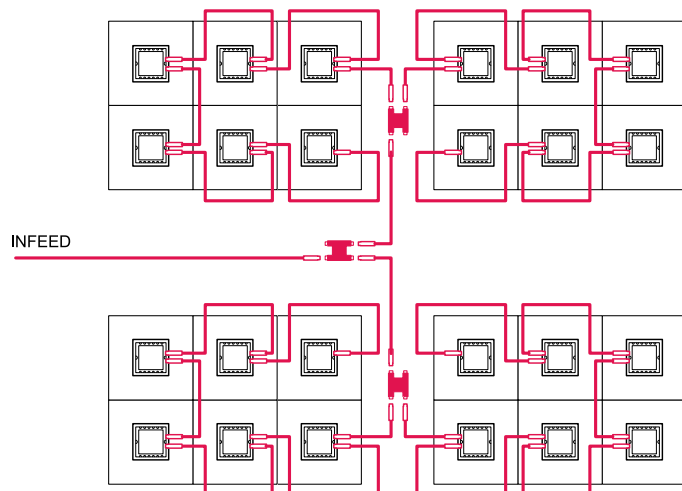

4-Circuit Furniture Infeed Applications

Note Examples are based on planning for an initial load of 12 amps per circuit. Check local electrical codes for maximum allowed electrical devices per circuit.

4-Circuit Furniture Infeed: Application 1

Electrical Load:

- 3 offices per feed
- 16 amps per office
(leaves 5.3 amps per office for future growth)

Requires:

- 1 Zone Distribution Box
- 2 Jumpers
- 2 Splitters
- 2 Furniture Base Feeds

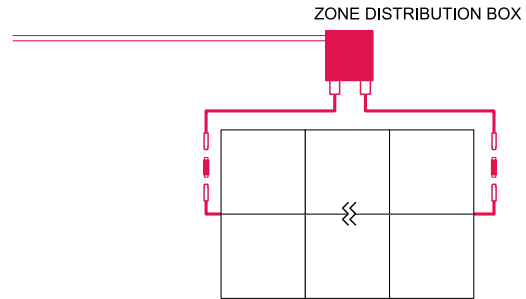

4-Circuit Furniture Infeed: Application 2

Electrical Load:

- 6 offices per feed
- 8 amps per office
(leaves 2.6 amps per office for future growth)

Requires:

- 1 Infeed Harness
- 1 Splitter
- 1 Furniture Base Feed

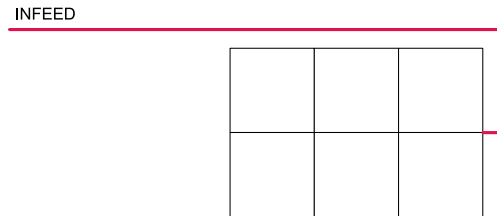

4-Circuit Furniture Infeed: Application 3

Electrical Load:

- 24 offices per feed
- 2 amps per office
(leaves 0.6 amps per office for future growth;
maximize size of floor box zone even if a
lower amps per office is desired)

Requires:

- 1 Infeed Harness
- 2 Jumpers
- 3 Splitters
- 4 Furniture Base Feeds

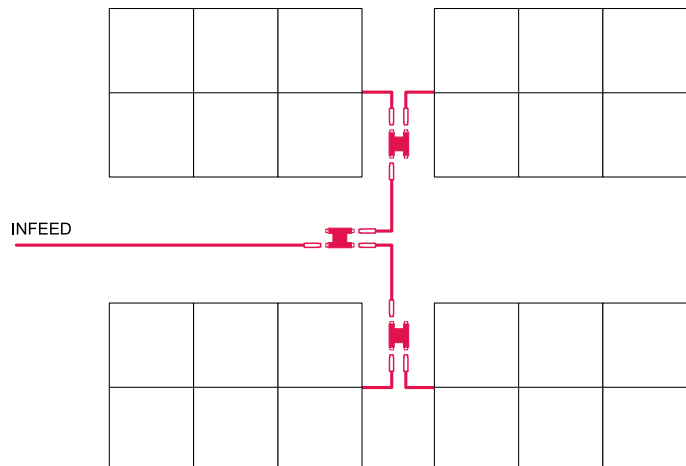

Planning Guide

Planning For The Future

The best time to plan for the future is while planning the installation of a new office space today. Future needs can be accommodated by planning for some extra capacity in the original project. All Power Base AI components are fully populated with all eight wires to support future reconfigurations. One way to plan in extra capacity is to use 12 amps per circuit instead of the 16 amps per circuit allowed by the Electrical Code (U.S.). The 4 amps of extra capacity allow for future unseen additional electrical requirements, like a printer being added to a work area. If a zone needs a large increase in power capacity, you can add another Infeed Harness and circuit distributor and reroute half the existing zone to this new Infeed Harness.

Planning A Project

The ten easy steps below and detailed on the following pages help determine the layout of the Power Base AI modular components. These ten steps will lead to a detailed layout and a detailed bill of materials. From the detailed bill of materials, final pricing can be determined and the Power Base AI product can be ordered through Haworth Orderline. Typically, as projects progress, more information is developed and more detail is required. During early stages of a project it may be more appropriate to use simplified tools such as the Power Base AI Budget Calculator tool to estimate pricing or materials that may be required for a project. All power components are populated with all eight wires to support future reconfigurations (except for Hardwire power applications).

Planning for Power Base AI in Ten Steps:

1. Identify the User's Needs
2. Identify the Building Power Location
3. Identify Access Devices
4. Electrical Code and Performance Factors
5. Determine Size of Zones
6. Specify Access Points
7. Specify Zone Distribution Boxes and Homeruns
8. Specify Jumpers and Splitters
9. Assign Circuit Breakers
10. Obtain Approvals

Planning for Power Base AI in Ten Steps

Step 1: Identify the User's Needs

Start by gathering basic information from written specifications, engineering drawings, or a questionnaire such as the "Request for Technology" form.

- In what country is the project located?
- How many square feet is the project?
- How many offices and workstations are there?
- What size are the offices and workstations?
- How much power is required per user?
- What is required: 3-Circuit or 4-Circuit power?
- If 4-Circuit power is required, is it a 3+1 or a 2+2 configuration?
- Is the systems furniture non-powered or powered with a 3-Circuit or 4-Circuit (3+1 or 2+2) configuration?
- How many outlets are required per office and workstation?
- Are there any pieces of equipment requiring special power requirements?
- Is there any equipment requiring more than 20 amps?
- Is there a need for a secondary power source(s) such as Uninterruptible Power Supply (UPS), generator, or other source?
- What access floor are you using and what is its height?

Notes 1. For large machines, a separate power feed direct from electrical panel to that machine may be the best solution. Planning for these large machines is better handled separate from the zone planning approach.

2. Secondary source(s) may be used to power 'mission critical' equipment to keep business operations running despite power outages. This enhanced level of power supply performance requires more specific planning steps in routing power and circuit designations. The principles of the zone planning methodology still apply, but some additional components may be required to deliver the secondary power source to required locations.

Planning for Power Base AI in Ten Steps

Step 2: Identify the Building Power Locations

Power is typically delivered from an electrical closet where the service panel is located. Identify where this is on the floor plan to help plan from where power will be routed.

Confirm that there is enough capacity available in the electrical closet to supply the power required by the user. For example, if there are 119 workstations using 4 amps each, that requires 476 available amps (119 x 4). If the building provides a panel with a 400 amp service there is not enough capacity to supply the user's power requirements. In this case the incoming service will require upgrading or less power can be supplied per station. Refer to Planning Guide Drawing A.

Planning Guide Drawing A: Power Locations

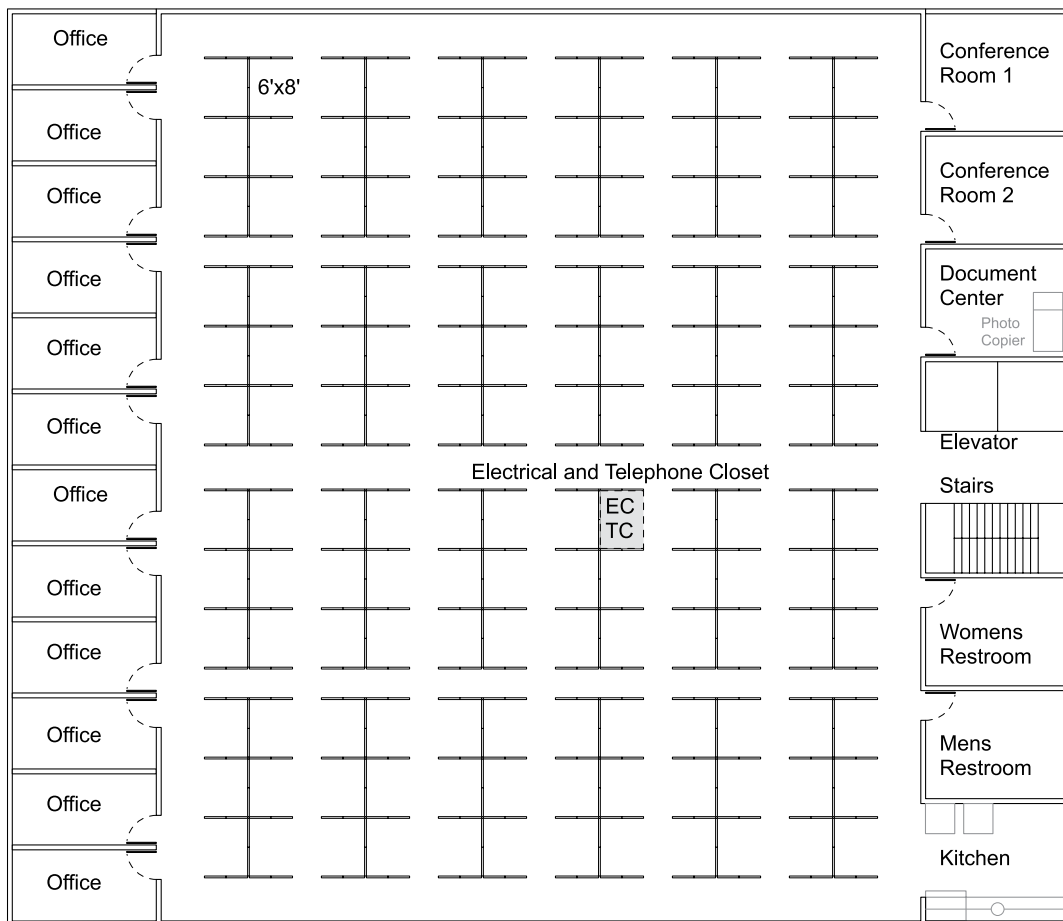

When laying out the power homeruns and Power Base AI components be aware of the data cable runs to minimize crossover points

Planning for Power Base AI in Ten Steps

Step 3: Identify Access Devices

- Determine what method(s) of power delivery may be required for the project.
- To power Haworth systems furniture, specify Haworth power infeeds. Non-powered systems furniture require delivery of power with the use of Service Modules. LifeSPACE panels with Level 4 power will require Jumpers to the Zone Distribution Box. LifeSPACE panels with Level 3 Power or powered non-Haworth systems furniture may be fed from a 1-Port Zone Distribution Box.
- Place power access devices (Service Modules, furniture feeds and/or wall feeds) where required on floor plan. In Planning Guide Drawing B, we use Flush Service Modules to supply power to the workstations. Haworth wall feeds connect to Jumpers by using a Splitter or connect directly to a Service Module or Zone Distribution Box. Systems furniture feeds may use the power of an Infeed Harness with just one feed, depending on loading per cluster size.
- Identify quantity of devices required per office.

Planning Guide Drawing B: Access Devices

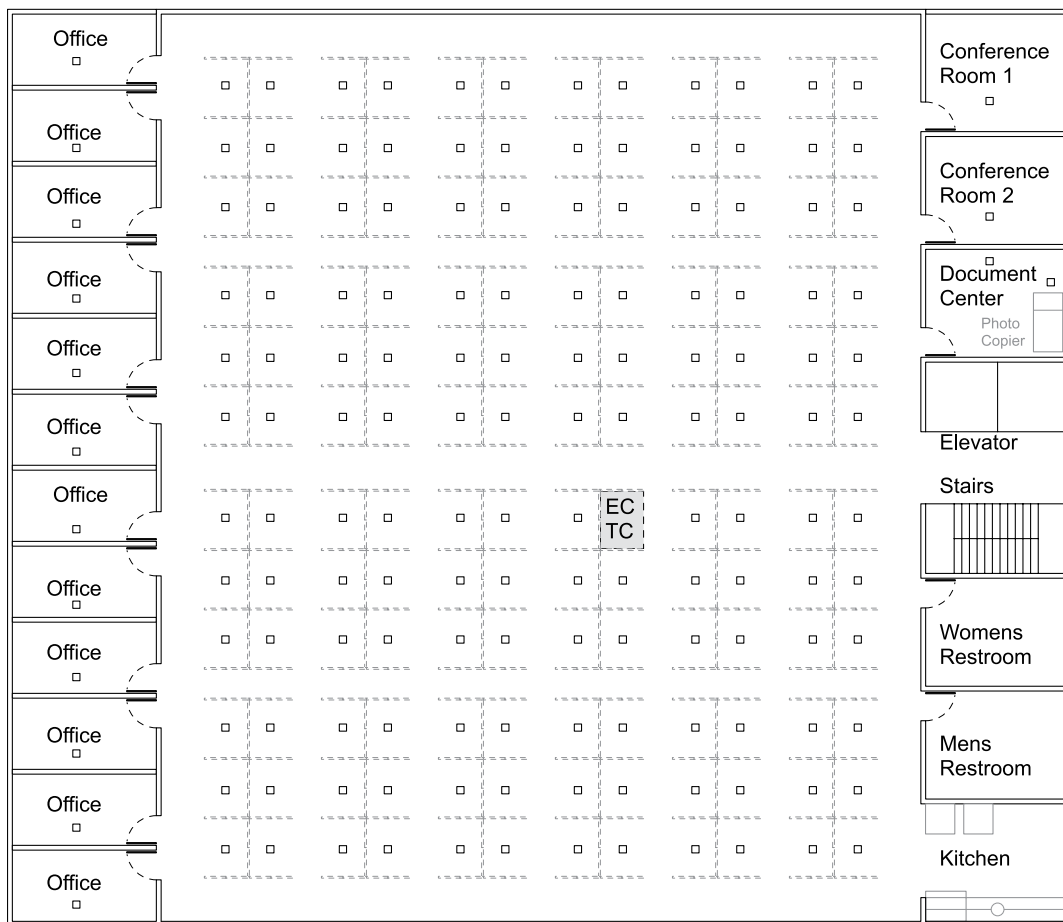

Planning for Power Base AI in Ten Steps

Step 4: Electrical Code and Performance Factors

National and local building and electrical codes exist to ensure occupant safety. These codes create guidelines that govern product application. Below is a summary of common code guidelines that may affect Power Base AI applications.

- **Circuit Capabilities and Code Restrictions**

Each circuit in the Power Base AI modular electrical system carries a maximum load of 20 amps (15 amps in Canada) of electrical service. However, applicable national and local codes may further restrict the current usage of the power distribution system. For example, the National Electrical Code (NEC) dictates a load requirement of no more than 80% (16 amps U.S.) capacity for continuous load situations (constant use of a circuit for three or more hours). Examples of continuous use loading include circuits that supply lighting, computers, and printers with power throughout the day. In practice, most circuits are subjected to continuous load.

- **Planning for Future Growth**

Based on the circuit load capacity of 16 usable amps per continuous-use circuit (U.S.), Haworth recommends that the initial loading on each circuit be approximately 12 amps. This initial planning limitation permits the user to add or change electrical equipment within the guidelines of local amperage limits. If you allow maximum amperage loading of 16 amps on each circuit, now you will restrict the future addition of equipment and may force a redesign of the electrical layout.

- **Voltage Drop**

The natural resistance of the wires causes voltage to fall away from the ideal voltage (120V in North America). The farther your circuit travels from the electrical closet the more voltage drop will occur. The NEC requires that voltage drop be no more than 5% from the ideal voltage. To limit how far the systems falls below the ideal voltage, limit the length of the circuits to less than 80' from a Zone Distribution Box or Infeed Harness.

- **Number of Receptacles**

The NEC also restricts the number of receptacles on a 20-amp rated circuit to thirteen (ten in Canada). These are maximum limits only and not recommendations. Local codes may also further restrict current location, number of circuits, or number of receptacles.

- **REGARD LOCAL CODES CAREFULLY**

Local codes supercede national codes. Local codes may restrict electrical plans more than national codes. A local code may reduce the number of receptacles and/or jumper cables allowed on each circuit.

Within local code guidelines, limit the receptacle installation to the maximum necessary to power the equipment in the current work station plan. Avoid providing receptacles for projected needs, because surplus receptacle availability may encourage use of unauthorized equipment and lead to electrical overloads.

Planning for Power Base AI in Ten Steps

Step 5: Determine the Size of the Zone

In most applications you will have to subdivide the floorplate into smaller sections, called "zones", that can be supplied by one set of 3- or 4-Circuits. An Infeed Harness can route from the electrical closet to each zone. The Zone Distribution Box routes two or three sets of circuits to an area of the building. Jumpers can be used to route a single set of circuits from the Zone Distribution Box to each zone. A 3-Circuit infeed provides 36 amps and a 4-Circuit infeed provides a total of 48 amps for distribution to the users (if using 12 amps per circuit for initial planning).

Dividing the floorplate into zones determines the number and locations of the Infeed Harnesses or Zone Distribution Boxes needed to provide the required power requirements to each area (refer to Planning Guide Drawing C). There are two methods of determining the number and location of the Zone Distribution Boxes.

1. Furniture Layout Available

Using the information from Step 1, calculate how many offices can be supplied by a set of circuits. Multiply number of circuits times amps/circuit then divide by amps/person to determine offices/zone. In our example we used $3 \text{ circuits} \times 12 \text{ amp/circuit} \div 4 \text{ amps/person} = 9 \text{ offices/zone}$. Divide the floor up into zones based on the number of office/zones. Sometimes physical constraints within the layout make it inconvenient to reach the maximum office/zone number calculated above. Using less than the maximum offices/zone is okay but more zones may be required to cover the floor plan. Try to keep the zones closer to a square shape rather than a long rectangle to keep Jumper lengths to a uniform size to more easily facilitate future reconfiguration requirements. Power access within a zone may be accomplished by floor, furniture, or wall based receptacles.

2. Furniture Layout Not Available

An alternate approach to determine the zone uses the work station size and the number of amps required per station from Step 1. Determine how many offices can be supplied by a Zone Distribution Box and then multiply by the area each office covers to find total area supplied by one Zone Distribution Box. Divide the floorplate into zones of this area. Don't forget to include aisle space around each workstation when calculating the total area of a zone.

For example if the workstations are 6' x 8', add 2' along one side for aisle way allowance. That makes the work station area 8' x 8', or 64 square feet. Using the information from Step 1, calculate how many offices can be supplied by a Zone Distribution Box. Multiply number of circuits times amps/circuit then divide by amps/person to determine offices/zone. In our example we used $3 \text{ circuits} \times 12 \text{ amp/circuit} \div 4 \text{ amps/person} = 9 \text{ offices/zone}$. Multiply the number of square feet per station by the number of stations to determine the zone. Therefore, 9 workstations at 64 square feet each is a 576 square foot zone (approximately 24' x 24'). Subdivide the floor plan into zones which are 576 square feet. Try to keep the zones closer to a square shape rather than a long rectangle to keep the Jumpers shorter and of more similar length for future reconfiguration requirements. If you have to develop a plan without information on where the furniture will be, use longer Jumpers in Step 8 to give you more flexibility to adapt as furniture is added.

Tip See Planning Guide Drawing C: Zones.

Note Due to the large size private offices and conference rooms can cover, it may be better to limit the number of these rooms fed by a set of circuits to a maximum of four rooms. This will limit the likelihood of having a voltage drop issue. Large training rooms or auditoriums may require more than one zone. Rooms with lots of equipment, such as a document center, may use enough power to warrant a zone for just that room.

Planning for Power Base AI in Ten Steps

Planning Guide Drawing C: Zones

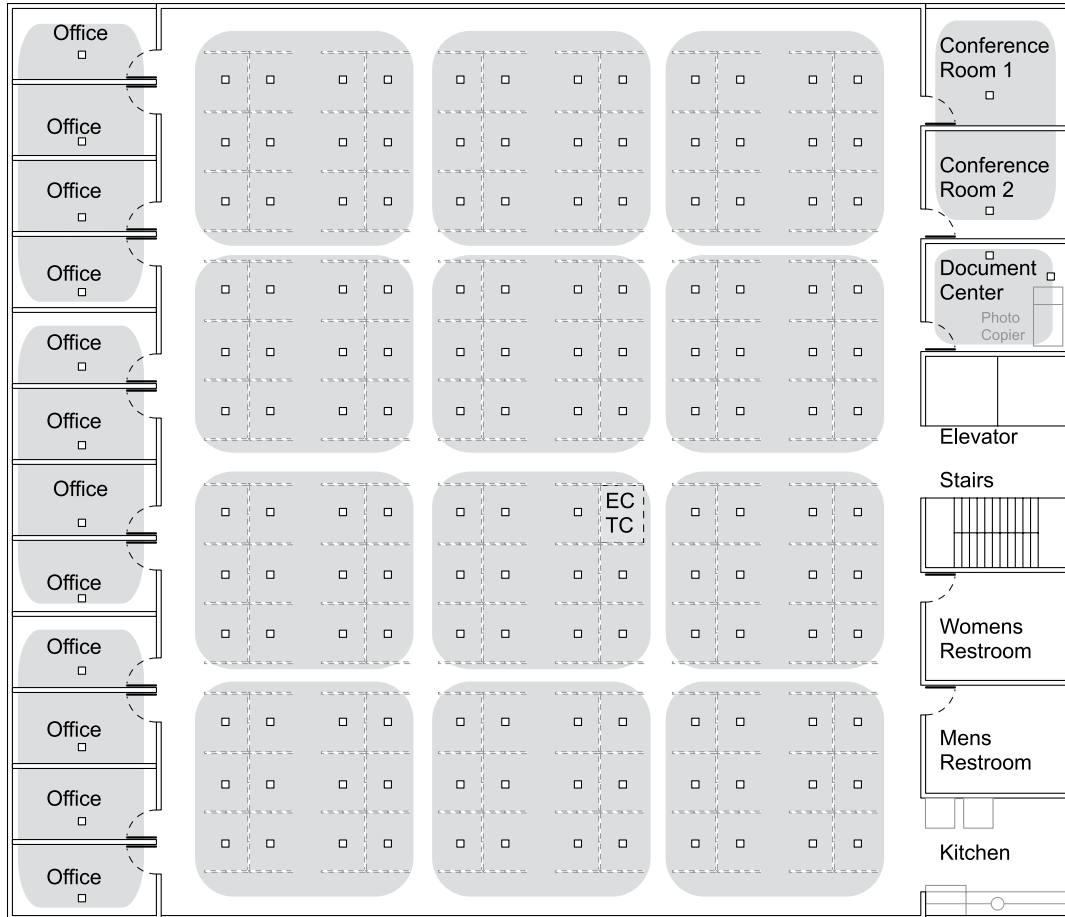

Planning for Power Base AI in Ten Steps

Step 6: Specify Access Points

• Flush Service Modules

When Service Modules are specified, specify location of module on floor plan. Order pre-cut floor tiles to receive the Service Module. Modular Receptacle should be ordered for the Service Modules. When specific circuits have been requested by the customer, order receptacles per the specifications provided. If circuit assignments have not been specified, start by assigning circuit one receptacles to the first Service Module in a zone and then circuit two for the second Service Module, and so on. Repeat assignment of all receptacles 1-3 for a 3-Circuit system or 1-4 for a 4-Circuit system.

• Powered Systems Furniture

If furniture Infeeds are specified, a similar planning process will be required for the systems furniture power outlets starting at the furniture feed. Receptacle locations and receptacle circuit assignments are required for the systems layout also. The receptacles in the systems furniture should also have a repeating pattern of 1-3 for a 3-Circuit application or 1-4 for a 4-Circuit application.

• Isolated Ground Receptacles

Additional information may be required if isolated ground receptacles are required for a project to allow for proper circuit planning. When computers or printers require an isolated ground circuit it may constitute a major portion of the power used by a workstation. When specific circuits have been specified by the customer, order circuits as per the specifications provided. For a 4-Circuit electrical system, if circuits have not been specified by the customer, it may be necessary to assign circuits three and four for use of the isolated ground receptacles leaving circuits one and two for utility power receptacles. The first workstation in this case may be assigned a circuit one for utility power and a circuit three for isolated ground power. The second workstation would be assigned a circuit two for utility power and a circuit four for isolated ground power. Repeat this pattern of circuit assignment for the remaining workstations.

Planning Guide Drawing D: Access Points

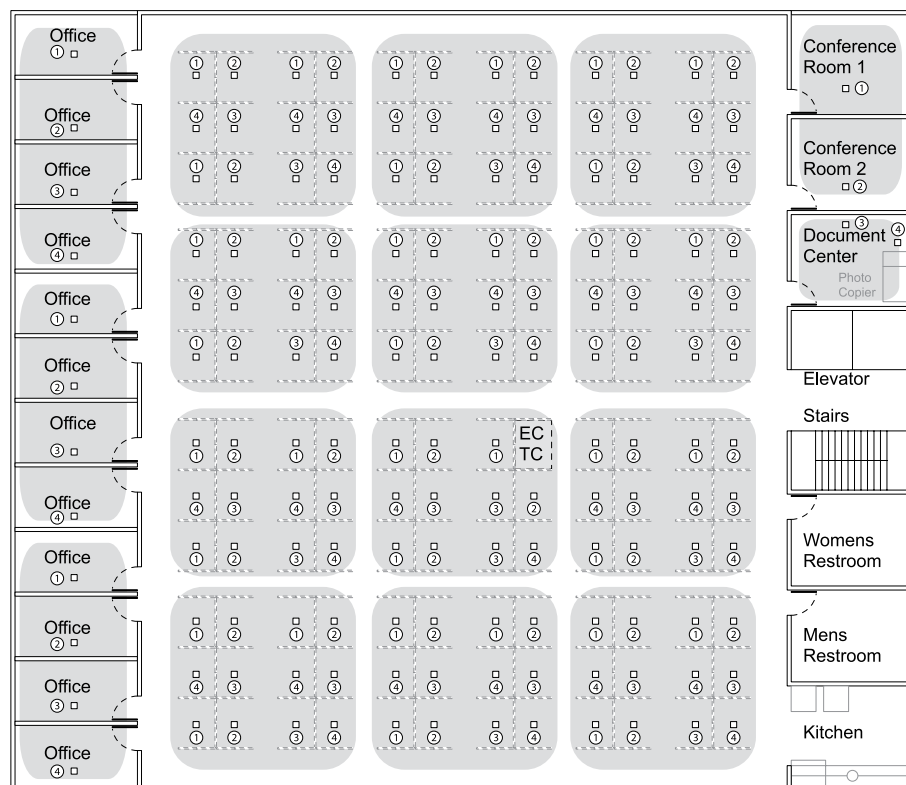

Planning for Power Base AI in Ten Steps

Step 7: Specify Infeed Harnesses or Zone Distribution Boxes

- Route an Infeed Harness from the electrical closet to each zone. For longer distances you may need to use a Zone Distribution Box to bring power from the electrical closet and Jumpers to reach into each zone. A Zone Distribution Box also may be more economical than an Infeed Harness where three zones are close together.
- Check for space restrictions when routing conduit to the electrical closet. Avoid excessive cross over of conduits. The pre-wired Zone Distribution Box conduit requires 2¼" height under the floor tile. For low profile floor applications, the use of MC cable and 1-Port Zone Distribution Boxes may be required.
- Also leave room for routing data cables. Try to keep parallel runs of power and data 4' apart to minimize cross talk.

Planning Guide Drawing E: Infeed Harnesses and Zone Distribution Boxes

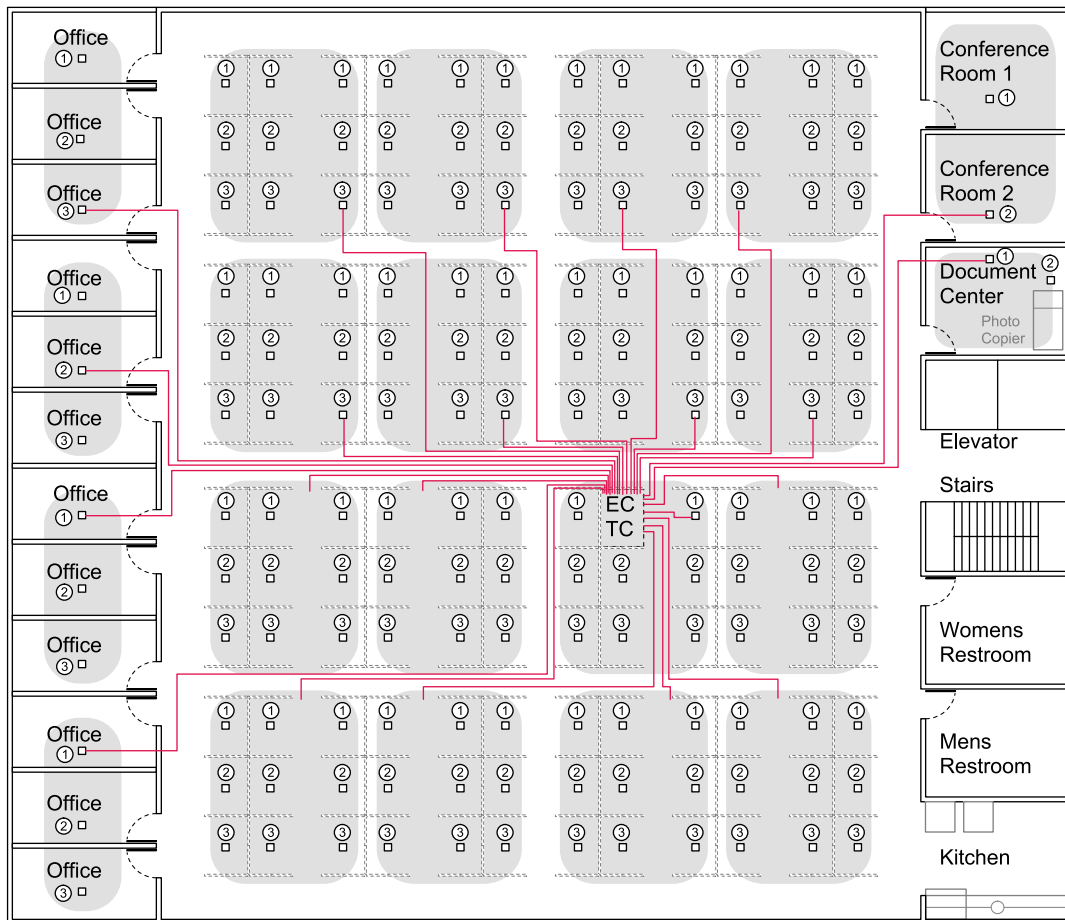

Planning for Power Base AI in Ten Steps

Step 8: Specify Jumpers and Splitters

Determine what Jumpers and Splitters are needed to power up Service Modules or Haworth base feeds (Refer to Planning Drawing F). Jumpers are used to connect Service Modules. The Quad Service Module has four ports for connecting Jumpers and the Dual Service Module has two ports. The Infeed Harness may connect to a Service Module. A Jumper is needed to route power from a Zone Distribution Box to the Service Module.

The Splitter is available in 2- or 4-Port models. The 4-Port model allows branching of the three Jumpers from a Jumper or Infeed Harness. The 2-Port model allows for connection of two Jumpers or between Jumper and Infeed Harness or furniture base feed.

Determine Jumper lengths required. Excess Jumper length may be coiled and left under the raised access floor for future use. Show Jumpers and circuit distributors on the floor plan. Indicate Jumper lengths on the drawing.

Planning Guide Drawing F: Jumpers and Splitters

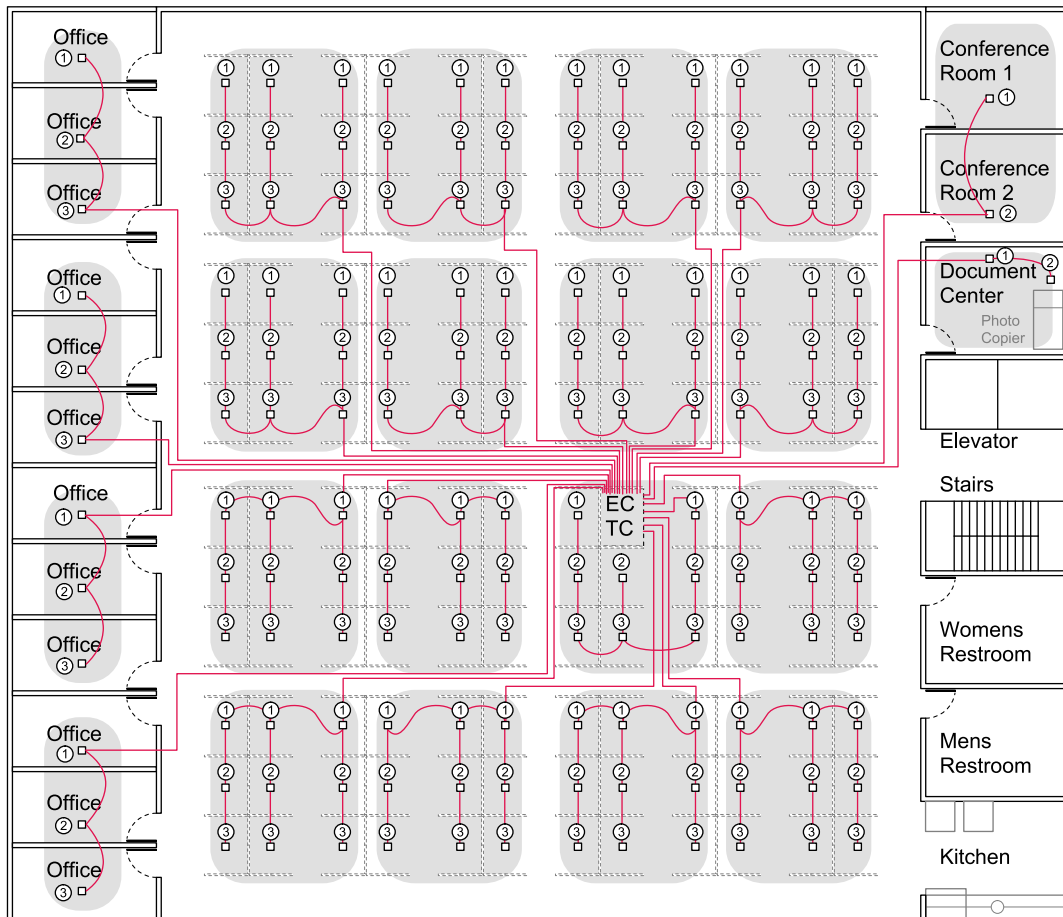

Planning for Power Base AI in Ten Steps

Step 9: Assign Circuit Breakers

- Designate on the floor plan which circuit breakers feed the conduit for each zone (Refer to Planning Drawing G). Use the circuit numbering provided on the engineering drawing. If no information is available from the engineering drawings, an electrician assigns the circuits.
- Add legend and electrical connection diagrams to layout drawings to assist with installation.
- Large pieces of equipment such as photocopiers should be assigned a separate breaker. The assignment of circuits and circuit breakers in a multiple power sourcing application is critical to assure safety, code compliance, and proper performance. When alternate power sources are specified, detailed information may be required regarding the circuit breakers assigned to these power sources.

Planning Guide Drawing G: Circuit Breakers

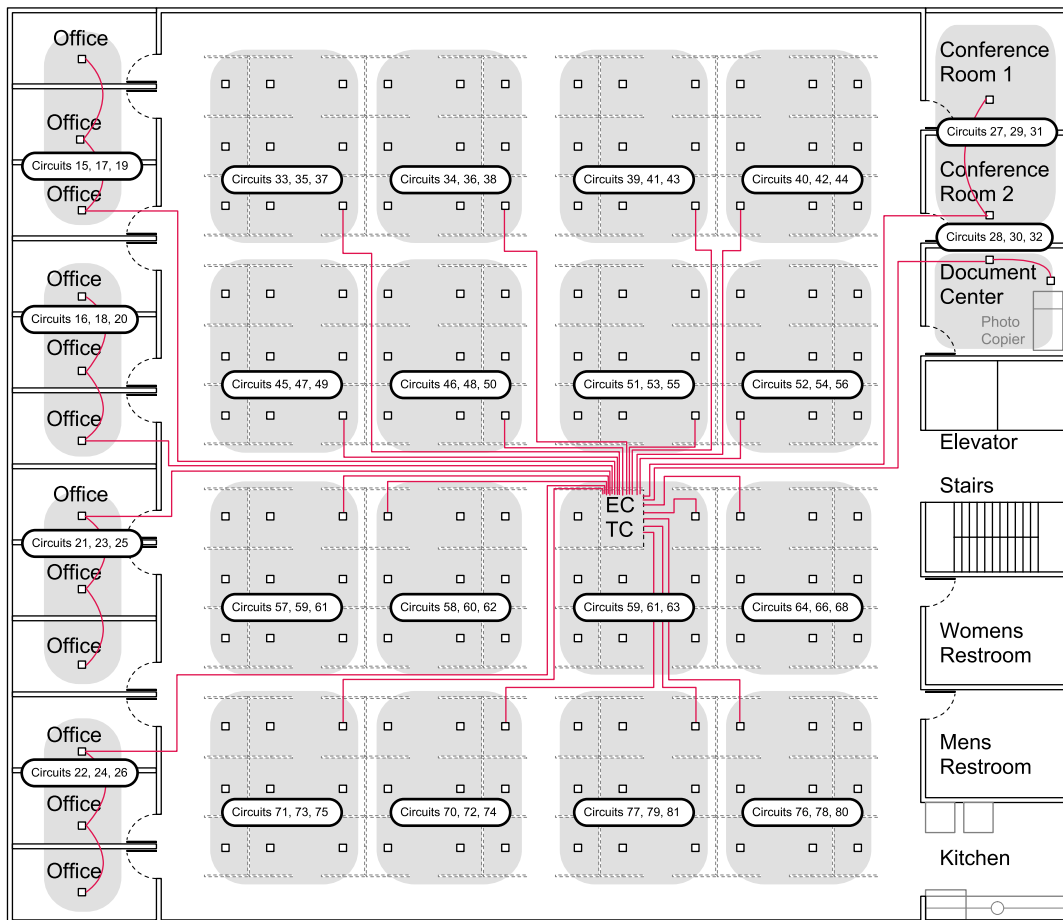

Step 10: Obtain Approvals

The underfloor power is typically seen as part of the building's infrastructure. It is better to communicate your plan back to several parties involved with the construction. These may include the Customer, Architect, Specifying Electrical Engineer, Electrical Subcontractor and Others. Obtain signature approvals from appropriate participants to verify proper communication has been made on this construction project.

Technical Specifications

Infeed Harness

Infeed Harness is constructed of ½" flexible metal conduit 12 AWG wire (10 AWG for shared neutral) up to 50 feet. For 50 feet or beyond, harness is constructed of ¾" flexible metal conduit 10 AWG wire. Provided with male modular connector at one end and conduit fitting on the other end. Infeed Harnesses are available in lengths of 15', 10', 25', 50', 75', and 100' in either 8-Wire 3-Circuit (3-3-2 separate neutral) wiring configurations or 4-Circuit (4-2-2 shared neutral) wiring configurations to support a 3+1 or 2+2 wiring configuration. The 3- and 4-Circuit versions are keyed to prevent mixing of configurations. UL Listed Manufacturing Wiring System rated for 20 amp 120V/208V or 120V/240V 60 Hz and for use in other air handling spaces per National Electrical Code Article 604. Supports plug-and-play power within each power zone. Flexible conduit construction with quick connect modular power connectors allows for quick install and easy reconfiguration. Infeed Harnesses are used to connect from building Circuit Breaker Box to Service Modules or Splitters or from Zone Distribution Boxes to a hardwire junction box connection. May be connected to Jumpers, base feeds, and modular wall connectors by using a Splitter.

Zone Distribution Box

Box is constructed of 0.575" – 0.0635" (16 gauge) thick black zinc-plated steel box with cover. The 3-Port Zone Distribution Box is provided with one 1¼" conduit containing twenty-one 10 AWG wires with conduit in lengths up to 125'. This is intended to be connected to the building Circuit Breaker Box. Three modular female ports are factory wired, ready for modular Jumpers. The 2-Port Zone Distribution Box is provided with one 1¼" conduit containing fourteen 8 AWG wires in lengths 150' – 200'. This is intended to be connected to the building Circuit Breaker Box. Two modular female ports are factory wired, ready for modular Jumpers. The 1-Port Low Profile Zone Distribution Box is intended to be connected to the building Circuit Breaker Box by a licensed electrician using ½" or ¾" conduit and appropriately sized wire. Wire leads inside the box are connected to a modular port, ready for a modular Jumper. The 3-Port Zone Distribution Box is also available in field wired configuration. This is intended to be connected to the building Circuit Breaker Box by a licensed electrician using 1¼" conduit and appropriately sized wire. Terminal strips inside the box are connected to three modular ports, which are factory wired, ready for modular Jumpers. All Zone Distribution Boxes are available 8-Wire 3-Circuit (3-3-2 separate neutral) wiring configurations or in 4-Circuit (4-2-2 shared neutral) wiring configurations to support 3+1 or 2+2 wiring configurations. The 3- and 4-Circuit versions are keyed to prevent mixing of configurations. UL Listed Manufacturing Wiring System rated for 20 amp 120V/208V or 120V/240V 60 Hz and for use in other air handling spaces per National Electrical Code Article 604. 2- and 3-Port Zone Distribution Box is 2.125" H x 11.06" W x 11.06" L. Box height of 2.125" allows for 4" or higher finished TecCrete Raised Access floor height. The 1-Port Zone Distribution Box is 1.75" H x 3" W x 7" L. Box height of 1.75" allows for a 3" or higher TecCrete Raised Access Floor finished floor height. The Zone Distribution Box does not replace access floor pedestal supports.

Jumpers

Jumpers are constructed of flexible conduit with quick connect modular male power connector heads at both ends. Available with either 12 AWG (10 AWG shared neutral) or all 10 AWG wires, the 12/10 AWG is ⅝" oval flexible metal conduit and all 10 gage is in a ¾" oval flexible metal conduit. Modular connectors are provided with integral latching system and include snap-in safety covers per NEC Article 604. Cables are available in length of 5', 10', 15', 20', 25', 35' and 50' in either 8-Wire 3-Circuit (3-3-2 separate neutral) wiring configurations or in 4-Circuit (4-2-2 shared neutral) wiring configurations to support 3+1 or 2+2 wiring configurations. The 3- and 4-Circuit versions are keyed to prevent mixing of configurations. Jumpers interconnect modular power components within each power zone. Supports plug-and-play power within each power zone. Flexible conduit construction with quick connect modular power connectors allow quick install and easy reconfiguration. Use to connect between Zone Distribution Boxes and Service Modules. Jumpers cannot be connected together directly, use a Splitter to interface between adjoining female connector heads. Use a Splitter to connect to Haworth furniture plug-and-play base feeds or infeeds. UL Listed Manufacturing Wiring System rated for 20 amp 120/208V or 120/260 60 Hz and for use in other air handling spaces per National Electrical Code Article 604.

Technical Specifications

Splitters

Splitter have a female connection configuration and are constructed of eight tin plated copper busbars within polymeric enclosure with integral latching system. Available in either 8-Wire 3-Circuit (3-3-2 separate neutral) wiring configuration or in 4-Circuit (4-2-2 shared neutral) wiring configurations to support 3+1 or 2+2 wiring configurations. The 3- and 4-Circuit versions are keyed to prevent mixing configurations. 4-Port Splitters have four female ports allowing it to interconnect up to four Jumpers within each power zone. One port is intended for the power supply connection with the ability to distribute out to the other three ports. 2-Port Splitters have two female ports connecting up to two Jumpers within a power zone. One port is intended for the power supply connection with the ability to connect to the other port. Supports plug-and-play power distribution with each power zone. Quick connect modular power connection allows quick install and easy reconfiguration. Typically one acts as the inlet and the others are outbound branches. UL Listed Manufacturing Wiring Systems rated for 20 amp 120V/208V or 120V/240V 60 Hz and for use in other air handling spaces per National Electrical Code Article 604. Splitters come with snap in safety covers per NEC Article 604. Splitters connect to male connectors of Jumpers and Haworth furniture plug-and-play base feeds. Splitters cannot connect directly to female connections of Zone Distribution Box or Service Modules.

Service Module

Flush Service Module constructed of 0.0575" – 0.0636" (16 gauge) thick black zinc-plated steel box. 2.5" high Dual Service Module is constructed with two integral females connectors for connection to Jumpers or Infeed Harnesses. 4.5" high Quad Service Module is constructed with four integral female connectors for connection to Jumpers or Infeed Harnesses. Receptacle/Data plates are concealed under hinged lid. Powdercoat painted lid and trim ring with twelve small ports in lid for cords and cables to exit the box. Lid accepts carpet insert. Unit fits 10½" square opening in raised access floor tile. Unit is secured to floor tile using four mounting screws. Available in either 8-Wire 3-Circuit (separate neutral) wiring configurations or in 4-Circuit (shared neutral) wiring configurations to support 3+1 or 2+2 wiring configurations. The 3- and 4-Circuit versions are keyed to prevent mixing of configurations. Dual Service Module accepts two Modular Receptacles, which are available separately, with common or isolated ground receptacles and four furniture info plates. Each opening has a knockout to accept a single gang data plate. Data plates or furniture info plates are provided by Others. The Dual Service Module is designed for use in 3" or higher TecCrete access floor finished floor height. 4.5" high Quad Service Module accepts four Modular Receptacles, which are available separately, with common or isolated ground receptacles and two furniture info plates. Each opening has a knockout to accept a single gang data plate. Data plates or furniture info plates are provided by Others. The Quad Service Module is designed for use in 4.5" or higher TecCrete access floor finished floor height. Flush Service Modules are used to provide power and data at floor level. Outlets are located under hinged lid which is flush with finished floor. Supports plug-and-play power distribution with each power zone. Quick connect modular power connection allows quick install and easy reconfiguration. Typically one acts as the inlet and the others are outbound branches. UL Listed Manufacturing Wiring System rated for 20 amps 120V/208V or 120V/240V 60 Hz and for use in other air handling spaces per National Electrical Code Article 604. Female connector head must be fed by male connector of Jumper or Infeed Harness. Female connector will not connect directly to female connector of Zone Distribution Box or Splitter.

Modular Receptacles

Modular Receptacles are constructed with plastic body and copper alloy terminals for quick connection to ports of the Service Modules. Available in NEMA 5-15R or 5-20R duplex configurations. When ordering specify which circuit is accessed and common or isolated ground configuration. UL Listed rated for 120V 60 Hz.

Systems Furniture Feed

Haworth Base feeds are constructed with male connector head for quick connect attachment to Zone Distribution Box or Service Module. Base feed may be connected to Jumper or infeed using a Splitter. Available in 3- or 4-Circuit configuration, depending on type of power available in the Haworth Furniture. Base feeds are UL/CSA listed for direct connection of systems furniture modular wiring directly to under floor power distribution.

Connection to non-Haworth furniture systems may be made via the 1-Port Distribution Box with a female connector on the box and an electrician hardwiring to the wires. The box is made of 0.0575" – 0.0635" (16 gauge) thick black zinc-plated steel. Junction box provides 46 cubic inches interior space. Conduit from systems furniture base feed may be connected to junction box via ½" and ¾" knockouts. Conductors may be joined to 8" leads of connector at the job site. Available with one 3- or 4-Circuit female connector.

Power Base AI

Three Part Specification Guide

PART 1 - GENERAL

1.01 Summary

A. This section includes the following:

The Haworth Power Base AI modular power system provides you with factory assembled UL Listed components which allow you to create a modular zone power distribution system for your facility. These "plug and play" components allow for a quick installation. This quick install reduces project schedule risk during the critical end phases of a construction project. The fully populated connectors provide flexibility for future moves, adds, and changes. The Zone Distribution Box supports more extensive changes in power demands. The system is available in three or four 20 A branch circuit wiring configurations to match wiring configurations of most systems furniture products. The system consists of the following components:

- Zone Distribution Boxes
- Jumpers
- Splitters
- Flush Service Modules
- Systems Furniture feed

B. Related Work Specified Elsewhere:

1. Section 09 69 00: Access Flooring
2. Section 12 06 50: Systems Furniture
3. Section 23 30 00: Mechanical air distribution

1.02 Environmental Conditions for Storage and Installation

A. The General Contractor must provide a dry accessible area to receive and unload material with a free path to elevators, hoists, and/or the area receiving the modular power components.

B. Prior to and during installation, a secure and dry storage space closed to the weather must be made available for the modular power components, with recommended environment at 40° F to 90° F and approximately 35% to 70% relative humidity, 24 hours a day during and after installation.

C. The subfloor surface must be free of moisture, dust, dirt and other debris. Once installed, the access floor must be maintained in the same manner.

1.03 Design Performance and Certification of Product

A. Design components to provide for quick-connect field assembly in a manner conducive to visual site inspection. Full wiring configuration shall be maintained throughout system to allow for future reconfigurations.

B. Products are designed to comply with NFPA 70, NEC Article 604 Manufactured Wiring Systems. Systems shall meet installation requirements for other air handling spaces in accordance with NEC 300.22 C. Products are designed to comply with Canadian Electrical Code, CEC.

C. Products shall be tested and listed per Underwriter's Laboratories Manufactured Wiring Systems (UL183) Standard for Safety.

1.04 Country of Origin

Product shall be assembled in United States.

1.05 Submittals

- A. Product Information: Technical Specification Sheets (Tech Sheets) of each system component type. Tech Sheets are to include product illustration, brief functional description, electrical ratings, construction details, conductor sizes, Agency Listings and dimensional drawings.
- B. Manufacturer's Installation Instructions for each component.
- C. Installation Drawings: Drawing of floor plan shall show all modular wiring system components and all connected receptacles configured in a zone distribution configuration. Drawings shall also include detail on connections to building wiring, legend of components, and a one-line diagram.
- D. Agency Listing verification certificate for each component of the system.

1.06 Quality Assurance

- A. Installer: A company which installs this product in compliance with license and permit requirements of the local Authority Having Jurisdiction.
- B. Manufacturing: Product to be assembled and tested per Agency (UL/CSA) listing requirements. Factory shall be inspected by listing agency representative on quarterly basis to assure compliance.

1.07 Project Conditions

- A. The General Contractor and/or Owner shall provide a clean, level, dry subfloor, temperature controlled, and protected from the weather.
- B. Power product and installation areas shall be maintained at a temperature between 40° F to 90° F and between 35% and 70% relative humidity for 24 hours the day before, during, and after installation.
- C. Overhead construction work must be completed before installing modular electrical system to avoid damage to product.

1.08 Regulatory Requirements

- A. Conform to all applicable municipal codes.
- B. NEC (National Electrical Code) or CEC (Canadian Electrical Code)

1.09 Warranty

- A. Provide manufacturer's standard 3 year warranty on defects in materials or workmanship.
- B. ISO 9001 certification

PART 2 - PRODUCTS

2.01 Manufacturer

- A. The modular power system shall be Haworth Power Base AI and manufactured by Haworth Inc., or approved equal. Product shall be assembled in United States.
- B. Substitutions will be considered, providing design criteria is met or exceeded.

2.02 General System Requirements

- A. The system shall provide a modular wiring system which provides quick connection of components to provide a zone distribution of 3- or 4-branch circuits to raised access floor boxes, systems furniture feeds, and or moveable wall receptacles. Component's wiring shall not be de-populated to impede future configurations. System shall fit within a 1.75" tall cavity under a raised floor.
- B. System Wiring Configuration: The system shall be available in the following configurations:
 - 1. 4-Circuit: Eight wires with four #12 AWG line conductors, one #10 AWG neutral conductor, one #12 AWG neutral, and two #12 AWG grounding conductors. Receptacle assemblies shall be compatible with 3+1 or 2+2 configurations described below:
 - a. 3+1 Configuration: three line conductors with shared neutral conductor; one line conductor with paired neutral; two grounding conductors.
 - b. 2+2 Configuration: two line conductors with shared neutral conductor, two line conductors with shared neutral, two grounding conductors.
 - 2. 3-Circuit: Eight wires with three #12AWG line conductors paired with three #12AWG neutral conductors; two #12AWG grounding conductors.
- C. System Ratings: The system shall be rated as 3- or 4-Circuit (20 Amp 120V/208Y 60 Hz). The system shall be UL 183 listed and certified to CSA 22.2 No. 203-M. Line conductors shall be #12AWG, neutral conductors shall be #10AWG (#12AWG if non-shared), grounding conductor shall be #12AWG.
- D. Connectors will be polarity keyed to prevent interconnection of 3- and 4-Circuit components.
- E. Components shall have a permanent label listing manufacturer, catalog number, CSA/UL listing. The component used to start the modular wiring zone shall have a means to indicate which electrical panel and circuit is used to feed to device. Receptacles are to indicate which circuit (1-4) within the modular wiring zone to which they are connected.

2.03 Components

- A. Zone Distribution Box: Used as transition point to convert from bulk power distribution into easily reconfigurable modular power distribution components. Supports "plug and play" power distribution within each power zone.
 - 1. 3-Port Distribution Box is constructed of 0.0575" – 0.0635" (16 gage) thick black zinc-plated steel box with cover. Provided with one 1¼" conduit containing twenty-one 10 AWG wires in lengths up to 125". This is intended to be connected to the building Circuit Breaker Box. Three modular ports are factory wired, ready for modular jumpers. Available in 8-Wire 3- or 4-Circuit wiring configuration.
 - 2. 2-Port Distribution Box is constructed of 0.0575" – 0.0635" (16 gage) thick black zinc-plated steel box with cover. Provided with one 1¼" conduit containing fourteen 8 AWG wires in lengths of 150" to 200". This is intended to be connected to the building Circuit Breaker Box. Two modular ports are factory wired, ready for modular jumpers. Available in 8-Wire 3- or 4-Circuit wiring configuration.

3. Field Wired Distribution Box is constructed of 0.0575" – 0.0635" (16 gage) thick black zinc-plated steel box with cover. This is intended to be connected to the building Circuit Breaker Box by a licensed electrician using 1¼" conduit and appropriately sized wire. Terminal strips inside the box are connected to three modular ports, which are factory wired, ready for modular jumpers. Available in 8-Wire 3- or 4-Circuit wiring configuration.
 4. Low Profile 1-Port Distribution Box is constructed of 0.0575" – 0.0635" (16 gage) thick black zinc plated steel box with cover. This is intended to be connected to the building Circuit Breaker Box by a licensed electrician using ½" conduit and appropriately sized wire. Wire leads inside the box are connected to a modular port, ready for a modular jumper. Available in 8-Wire 3- or 4-Circuit wiring configuration.
- B. Jumpers: Used to interconnect modular power components within each power zone.
1. Flexible conduit construction with quick connect modular male power connector heads. Available in 8-Wire 3-or 4-Circuit wiring configuration. Connector populated with all eight wires to support future reconfigurations of the power distribution system. Available in 5', 10' 15' and 20' lengths. Available with either all 10 gage or 10/12 gage wires, all 10 gage is a ¾" oval flexible metal conduit (MC) and the 10/12 gage is ⅝" oval flexible metal conduit.
- C. Splitters: Act as 'splitter' to interconnect up to four Jumpers within each power zone. Constructed with eight tin plated copper busbars within polymeric enclosure with integral latching system. Available in 3- or 4-Circuit configurations. Typically one acts as the inlet and the others are outbound branches.
- D. Service Modules: Used to provide power and/or data outlets at floor level.
1. 2.5" Dual Flush Service Module constructed of 0.0575" – 0.0635" (16 gage) thick black zinc-plated steel box with two integral female connectors. Receptacle/Data plates are concealed under hinged lid. Powdercoat painted (gray) lid and trim ring with hinged cord exit port. Lid accepts carpet insert. Unit fits in 10½" square opening in raised access floor tile. Unit is secured to floor tile using four mounting screws. Available in 8-Wire 3- or 4-Circuit configurations. Unit accepts two modular receptacles, which are specified separately, with common or isolated ground receptacles. Available in 2.5" 2-gang configuration. The box cover is capable of supporting a 1,000 lbf (4,448-N) concentrated load and remaining functional.
 2. 4.5" Quad Flush Service Module constructed of 0.0575" – 0.0635" (16 gage) thick black zinc-plated steel box with four integral female connectors. Receptacle/Data plates are concealed under hinged lid. Powdercoat painted (gray) lid and trim ring with hinged cord exit port. Lid accepts carpet insert. Unit fits in 10½" square opening in raised access floor tile. Unit is secured to floor tile using four mounting screws. Available in 8-Wire 3- or 4-Circuit configurations. Unit accepts four modular receptacles, which are specified separately, with common or isolated ground receptacles. Available in 4.5" 4-gang configuration. The box cover is capable of supporting a 1,000 lbf (4,448-N) concentrated load and remaining functional.
- E. Systems Furniture Feed: Used to connect systems furniture modular wiring directly to zone power distribution.
1. Haworth Base Feeds are constructed with male connector head for quick connect attachment to Jumpers of zone power system. Available in 3- or 4-Circuit configuration, depending on type of power available in the Haworth Furniture. Base feeds are UL/CSA listed for direct connection to the Jumpers.
 2. Connection to non-Haworth furniture systems may be made via the Low Profile 1-Port Zone Distribution Box with a female connector on the box and an electrician hardwiring to the wires. That box is made of 0.0575" – 0.0635" (16 gage) thick black zinc-plated steel. Junction box provides 46 cubic inches interior space. Conduit from systems furniture base feed may be connected to junction box via ½" and ¾" knockouts. Conductors may be joined to 12" leads of connector at the job site. Available with one 3- or 4-Circuit connector cable.

PART 3 - EXECUTION

3.01 Inspection

- A. Division 1 — Coordination and Meetings: Verification of existing conditions before starting work.
- B. Verify that field measurements are coordinated with shop drawings.
- C. Verify that required utilities are available, in proper location, and ready for use.

3.02 Installation

- A. Division 1 — Quality Control: Manufacturer's instructions.
- B. Install components in strict compliance with manufacturer's current published installation instructions.
- C. Install components in strict compliance of all municipal codes and governances.

3.03 Field Quality Control

Site Tests: Test completed installation in accordance with license and permit requirements of the local Authority Having Jurisdiction.

3.04 Acceptance

Certification: Client to receive certification from Installer that the installation meets the design specifications for this facility.

HAWORTH®

For more information call 800.344.2600 or 616.393.3000.



Cover is printed on 100% chlorine-free paper. Internal pages are manufactured with 10% post-consumer fiber.

Haworth is a registered trademark of Haworth, Inc.
Printed in USA ©Haworth, Inc. 2009 04.09 Item #1238

haworth.com | haworth-europe.com | haworth-asia.com