

Technical Data Sheet

Wind Designs & Securement for T. Clear Protected Membrane Roof Systems Using LIGHTGUARD® or HEAVYGUARD® Ballasts

Table Of Contents

Selection of Proper PMR System Design.....	pg. 1
General Design Considerations.....	pg. 1
ASCE 7-2002 Wind Speed Map.....	pg. 2
Building Exposures.....	pg. 4
LG/HG System Table Adhered Membrane.....	pg. 5-7
LG/HG System Table Loose-laid Membrane.....	pg. 8-9
LG/HG System Designs Metal Securement.....	pg. 10
LG/HG System Designs Paver Securement.....	pg. 18

Selection of the Proper Protected Membrane Roof System (PMR) Design

A designer of PMR roofs has three system designs to choose from. These systems vary with wind speed, building height, parapet height, and membrane attachment. The tables in this document are organized by membrane attachment method and building height. These tables list the ballast system design which is required.

To determine the ballast system design required for your roof, follow these steps:

- 1) Determine design wind speed.
(See ASCE 7-2002 Wind Speed Map, **Fig. 1**, page 2)
- 2) Determine building height.
- 3) Determine parapet height.
- 4) Determine building site exposure.
(See Building Exposures, page 4)
- 5) Choose roof membrane.
(Adhered or Loose-laid)
- 6) Choose LIGHTGUARD or HEAVYGUARD ballast.
- 7) Determine proper ballast system design requirement.
(Consult the appropriate LIGHTGUARD/HEAVYGUARD System Tables)

General Design Considerations

The following factors shall be considered when designing a ballasted PMR system:

Roof Structure

The building structure (new or retrofit) must be strong enough to support the present and future dead loads on the roof, including the ballast, as well as the anticipated live loads.

Slope

The roof slope should not exceed two inches in twelve inches. Slopes greater than 2/12 require technical approval.

Design Wind Speed

The design wind speed for the building location shall be determined from the ASCE 7-2002 Wind Speed Map, **Fig. 1**, page 2, or from the local code authority.

Roof Height

The roof height from the ground level to the top of the new roofing system may be different on different sides of the building. Therefore, height shall be based on the worst-case elevation.

Parapet Height

The height of the parapet wall shall be measured from the top of the ballast to the top of the parapet. If the height varies, the shortest parapet height should be used.

Gravel Stop

If a gravel stop is used at the building perimeter, its height above the ballast shall be a minimum of two inches to contain the ballast.

Figure 1 – ASCE 7-2002 Wind Speed Map

Map from ASCE 7-02, *Minimum Design Loads for Buildings and Other Structures*, ©2002, published by the American Society of Civil Engineers (ASCE). Reproduced by permission of the ASCE.

This information is extracted from ASCE-7-02; for further information, the complete text of the manual should be referenced (<http://www.pubs.asce.org/ASCE7.html?9991330>).

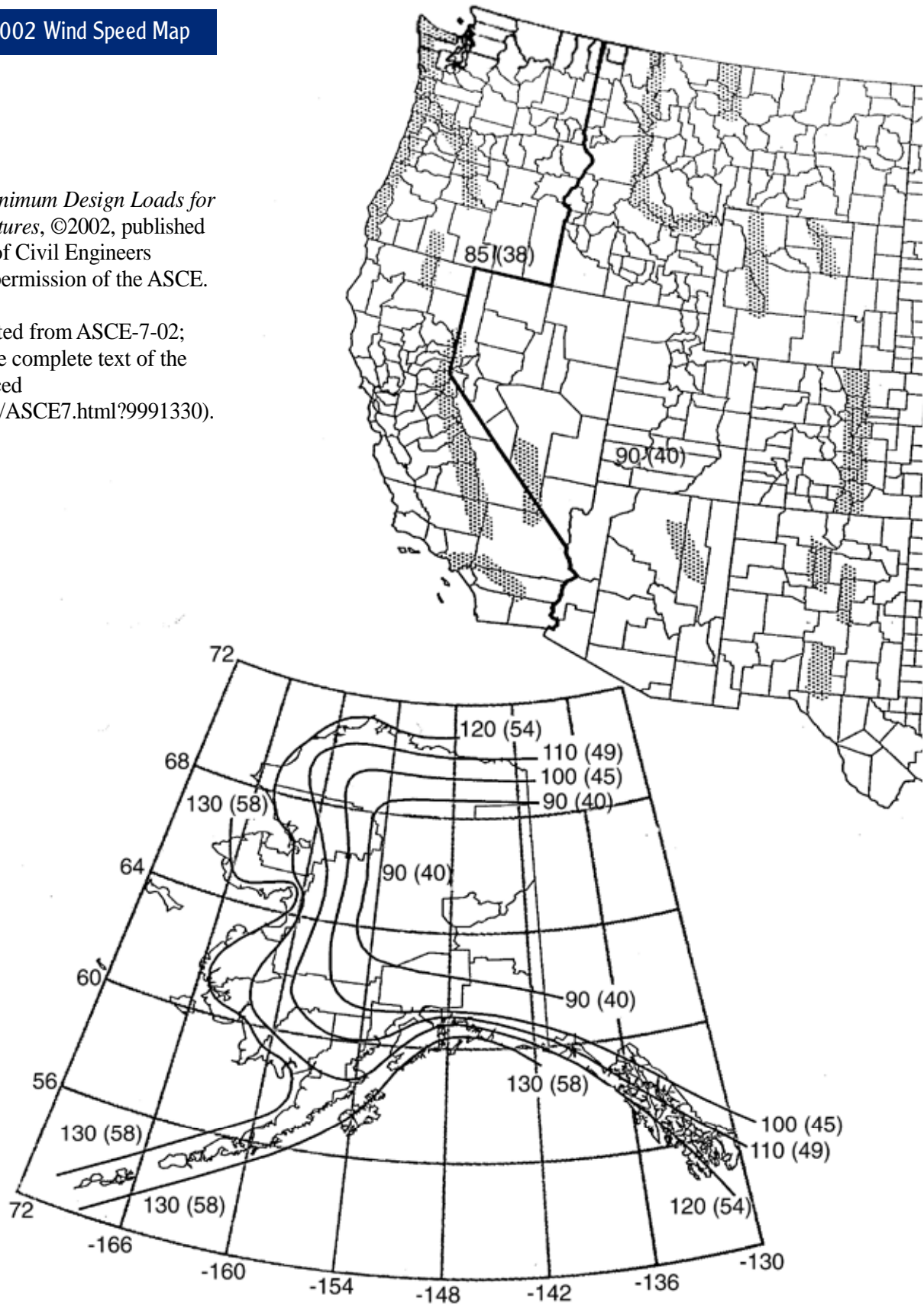

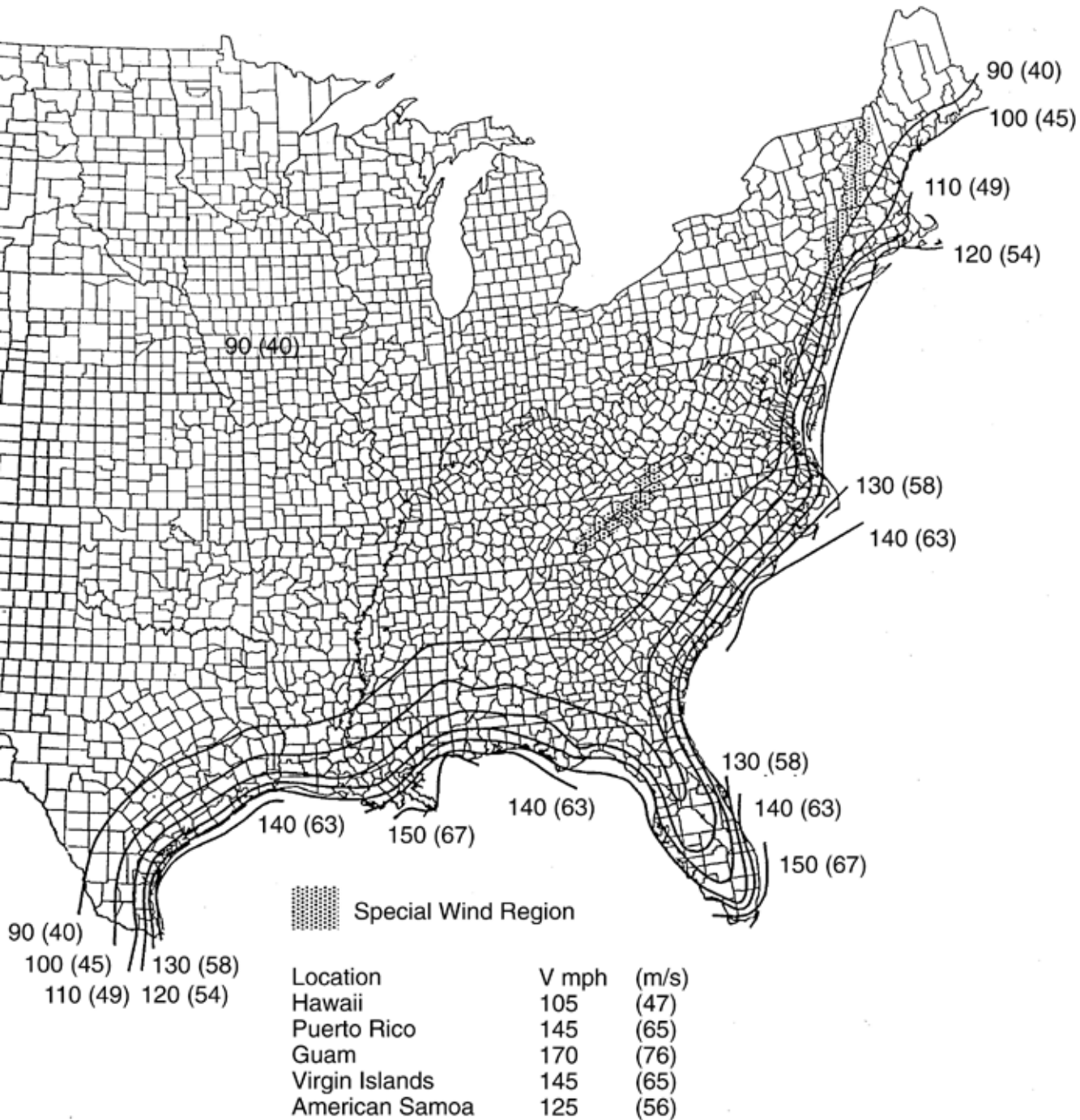

Notes:

1. Values are nominal design 3-second gust wind speeds in miles per hour (m/s) at 33 ft (10 m) above ground for Exposure C category.
2. Linear interpolation between wind contours is permitted.
3. Islands and coastal areas outside the last contour shall use the last wind speed contour of the coastal area.
4. Mountainous terrain, gorges, ocean promontories, and special wind regions shall be examined for unusual wind conditions.

Building Exposures

The surrounding terrain has an effect on the overall wind exposure of the building. The exposure in which a specific building or other structure is sited shall be assessed as being in one of the following categories:

Surface Roughness Categories:

Ground surface roughness within each 45° sector shall be determined for a distance upwind of the site from the categories as defined below, for the purpose of assigning an exposure category.

Surface Roughness B: Urban and suburban areas, wooded areas, or other terrain with numerous closely spaced obstructions having the size of single-family dwellings or larger. Exposure B shall apply where the ground surface roughness condition as defined by Surface Roughness B prevails in the upward direction for a distance of at least 2360 feet (800 m) or ten times the height of the building, whichever is greater. *Exception:* For buildings whose mean roof height is less than or equal to thirty feet, the upwind distance can be reduced to 1500 feet (457 m).

Surface Roughness C: Open terrain with scattered obstructions having heights generally less than 30 feet (9.1 m). This category includes flat open country, grasslands and all water surfaces in hurricane prone regions.

Exposure C shall apply for all cases where exposure B and D do not apply.

Surface Roughness D: Flat, unobstructed areas and water surfaces outside hurricane prone regions. This category includes smooth mud flats, salt flats and unbroken ice. Exposure D shall apply where the ground surface roughness, as defined by Surface Roughness D, prevails in the upwind direction for a distance at least 5000 feet (1524 m) or ten times the building height, whichever is greater. Exposure D shall extend inland from the shoreline for a distance of 660 feet (200m) or ten times the height of the building, whichever is greater.

For a site located in the transition zone between exposure categories, the category resulting in the largest wind forces shall be used. *Exception:* An immediate exposure between the categories is permitted in a transition zone provided that it is determined by a rational analysis method defined in the recognized literature.

Consult T. Clear Technical Service for specific design in Exposure D areas.

LIGHTGUARD® & HEAVYGUARD® System Tables For Adhered Membranes

A. FROM 2.5 INCH HIGH GRAVEL STOP TO LESS THAN 6.0 INCH PARAPET

Building Height Feet	MAXIMUM WIND SPEED (MPH)					
	System 1		System 2		System 3	
	Exposures C	Exposure B	Exposures C	Exposure B	Exposures C	Exposure B
0 - 15	130	140	140	140	140	140
> 15 - 30	120	140	130	140	130	140
> 30 - 45	120	140	120	140	120	140
> 45 - 60	120	140	120	140	120	140
> 60 - 75	120	130	120	130	120	140
> 75 - 90	NO	NO	NO	NO	NO	NO
> 90 - 105	NO	NO	NO	NO	NO	NO
> 105 - 120	NO	NO	NO	NO	NO	NO
> 120 - 135	NO	NO	NO	NO	NO	NO
> 135 - 150	NO	NO	NO	NO	NO	NO

B. FOR PARAPET HEIGHTS FROM 6.0 TO LESS THAN 12.0 INCHES

Building Height Feet	MAXIMUM WIND SPEED (MPH)					
	System 1		System 2		System 3	
	Exposures C	Exposure B	Exposures C	Exposure B	Exposures C	Exposure B
0 - 15	140	140	140	140	140	140
> 15 - 30	140	140	140	140	140	140
> 30 - 45	130	140	140	140	140	140
> 45 - 60	130	140	140	140	140	140
> 60 - 75	130	130	130	130	140	140
> 75 - 90	85	90	90	100	90	100
> 90 - 105	NO	NO	85	85	90	90
> 105 - 120	NO	NO	85	85	85	85
> 120 - 135	NO	NO	85	85	85	85
> 135 - 150	NO	NO	85	85	85	85

Consult T. Clear Technical Service for specific design in Exposure D areas.

LIGHTGUARD® & HEAVYGUARD® System Tables

For Adhered Membranes

C. FOR PARAPET HEIGHTS FROM 12.0 TO LESS THAN 18.0 INCHES

Building Height Feet	MAXIMUM WIND SPEED (MPH)					
	System 1		System 2		System 3	
	Exposures C	Exposure B	Exposures C	Exposure B	Exposures C	Exposure B
0 - 15	140	140	140	140	140	140
> 15 - 30	140	140	140	140	140	140
> 30 - 45	130	140	140	140	140	140
> 45 - 60	130	140	140	140	140	140
> 60 - 75	130	140	140	140	140	140
> 75 - 90	100	110	100	120	110	120
> 90 - 105	100	110	100	120	110	120
> 105 - 120	100	110	100	110	110	120
> 120 - 135	90	110	100	110	100	120
> 135 - 150	90	100	100	110	100	120
> 150 - 200	90	90	100	100	100	100
> 200 - 300	90	90	90	90	100	100
> 300 - 400	85	90	90	90	90	90
> 400 - 500	85	90	90	90	90	90

D. FOR PARAPET HEIGHTS FROM 18.0 TO LESS THAN 36.0 INCHES

Building Height Feet	MAXIMUM WIND SPEED (MPH)					
	System 1		System 2		System 3	
	Exposures C	Exposure B	Exposures C	Exposure B	Exposures C	Exposure B
0 - 15	140	140	140	140	140	140
> 15 - 30	140	140	140	140	140	140
> 30 - 45	140	140	140	140	140	140
> 45 - 60	140	140	140	140	140	140
> 60 - 75	140	140	140	140	140	140
> 75 - 90	120	140	130	140	140	140
> 90 - 105	120	130	130	140	130	140
> 105 - 120	120	120	130	140	130	140
> 120 - 135	120	120	120	130	130	140
> 135 - 150	120	120	120	130	130	130
> 150 - 200	110	110	120	120	130	130
> 200 - 300	110	110	110	110	120	120
> 300 - 400	110	110	110	110	120	120
> 400 - 500	100	100	100	100	110	110

Consult T. Clear Technical Service for specific design in Exposure D areas.

LIGHTGUARD® & HEAVYGUARD® System Tables For Adhered Membranes

E. FOR PARAPET HEIGHTS OF 36.0 INCHES OR MORE						
Building Height Feet	MAXIMUM WIND SPEED (MPH)					
	System 1		System 2		System 3	
	Exposures C	Exposure B	Exposures C	Exposure B	Exposures C	Exposure B
0 - 15	140	140	140	140	140	140
> 15 - 30	140	140	140	140	140	140
> 30 - 45	140	140	140	140	140	140
> 45 - 60	140	140	140	140	140	140
> 60 - 75	140	140	140	140	140	140
> 75 - 90	140	140	140	140	140	140
> 90 - 105	140	140	140	140	140	140
> 105 - 120	140	140	140	140	140	140
> 120 - 135	140	140	140	140	140	140
> 135 - 150	140	140	140	140	140	140
> 150 - 200	130	130	140	140	140	140
> 200 - 300	120	120	130	130	130	130
> 300 - 400	120	120	130	130	130	130
> 400 - 500	110	110	120	120	120	120

Consult T. Clear Technical Service for specific design in Exposure D areas.

LIGHTGUARD® & HEAVYGUARD® System Tables

For Loose-Laid Membranes

A. FROM 2.5 INCH HIGH GRAVEL STOP TO LESS THAN 6.0 INCH HIGH PARAPET

Building Height Feet	MAXIMUM WIND SPEED (MPH)					
	System 1		System 2		System 3	
	Exposures C	Exposure B	Exposures C	Exposure B	Exposures C	Exposure B
0 - 15	100	115	110	120	130	130
> 15 - 30	100	110	110	120	120	130
> 30 - 45	90	100	100	115	110	130
> 45 - 60	90	100	100	115	110	130
> 60 - 75	NO	NO	NO	NO	110	130
> 75 - 90	NO	NO	NO	NO	NO	90
> 90 - 105	NO	NO	NO	NO	NO	85
> 105 - 120	NO	NO	NO	NO	NO	NO
> 120 - 135	NO	NO	NO	NO	NO	NO
> 135 - 150	NO	NO	NO	NO	NO	NO

B. FOR PARAPET HEIGHTS FROM 6.0 TO LESS THAN 12.0 INCHES

Building Height Feet	MAXIMUM WIND SPEED (MPH)					
	System 1		System 2		System 3	
	Exposures C	Exposure B	Exposures C	Exposure B	Exposures C	Exposure B
0 - 15	110	130	115	130	120	130
> 15 - 30	100	130	110	130	120	130
> 30 - 45	90	110	100	115	110	130
> 45 - 60	90	110	100	115	110	130
> 60 - 75	NO	90	100	115	110	130
> 75 - 90	NO	NO	NO	NO	85	90
> 90 - 105	NO	NO	NO	NO	85	90
> 105 - 120	NO	NO	NO	NO	NO	NO
> 120 - 135	NO	NO	NO	NO	NO	NO
> 135 - 150	NO	NO	NO	NO	NO	NO

C. FOR PARAPET HEIGHTS FROM 12.0 TO LESS THAN 18.0 INCHES

Building Height Feet	MAXIMUM WIND SPEED (MPH)					
	System 1		System 2		System 3	
	Exposures C	Exposure B	Exposures C	Exposure B	Exposures C	Exposure B
0 - 15	110	130	115	130	130	130
> 15 - 30	110	130	110	130	120	130
> 30 - 45	100	120	110	120	110	130
> 45 - 60	100	120	110	120	110	130
> 60 - 75	100	110	110	120	110	130
> 75 - 90	90	90	90	100	90	110
> 90 - 105	NO	85	85	90	90	110
> 105 - 120	NO	NO	NO	NO	85	100
> 120 - 135	NO	NO	NO	NO	NO	90
> 135 - 150	NO	NO	NO	NO	NO	90

Consult T. Clear Technical Service for specific design in Exposure D areas.

LIGHTGUARD® & HEAVYGUARD® System Tables For Loose-Laid Membranes

D. FOR PARAPET HEIGHTS FROM 18.0 TO LESS THAN 36.0 INCHES

Building Height Feet	MAXIMUM WIND SPEED (MPH)					
	System 1		System 2		System 3	
	Exposures C	Exposure B	Exposures C	Exposure B	Exposures C	Exposure B
0 - 15	110	130	120	130	130	130
> 15 - 30	110	130	120	130	120	130
> 30 - 45	110	130	110	130	120	130
> 45 - 60	100	110	110	120	120	130
> 60 - 75	100	110	110	120	110	130
> 75 - 90	100	110	100	110	100	120
> 90 - 105	100	110	100	110	100	110
> 105 - 120	100	100	100	110	100	110
> 120 - 135	100	100	100	110	100	110
> 135 - 150	90	100	100	100	100	100

E. FOR PARAPET HEIGHTS OF 36.0 INCHES OR MORE

Building Height Feet	MAXIMUM WIND SPEED (MPH)					
	System 1		System 2		System 3	
	Exposures C	Exposure B	Exposures C	Exposure B	Exposures C	Exposure B
0 - 15	120	130	130	130	130	140
> 15 - 30	110	130	120	130	130	140
> 30 - 45	110	130	120	130	130	140
> 45 - 60	110	130	120	130	120	130
> 60 - 75	110	120	110	120	120	130
> 75 - 90	110	120	110	120	120	120
> 90 - 105	110	110	110	120	120	120
> 105 - 120	110	110	110	110	120	120
> 120 - 135	110	110	110	110	120	120
> 135 - 150	100	100	110	110	110	110

Note: An air barrier as described in T. CLEAR CORP. Technical Data Sheet #20, A Guide to Achieve the Secure Single-Ply Roof, is required with all loose-laid membrane installations.

Consult T. Clear Technical Service for specific design in Exposure D areas.

LIGHTGUARD® & HEAVYGUARD® System Tables

Metal Securement

System 1

Metal Securement (Fig. 10, page 11 & 12)

The metal perimeter edge securement must be securely fastened to the perimeter of the roof structure, whether it be a nailer or wall, using the appropriate number and type of fasteners as specified by the designer. The metal perimeter securement must be secured a maximum of 12 in. (30 cm) O.C., and shall resist uplift pressures of 100 lbs./lineal ft. minimum. At gravel stops, the metal shall be secured into the upper most wood nailer. The metal perimeter edge securement shall not run for continuous lengths over 12 ft. (3.7 m). The metal perimeter edge securement must be attached to a terminating LightGuard®/HeavyGuard® board that has tongue and groove integrity and is equal to or greater than 6 in. wide.

Shop Fabricated Metal:

The metal counter flashing/gravel stop securement shall extend a minimum of 6 in. (15 cm) onto the surface of the board and be attached 18 in. (46 cm) O.C. using approved fasteners. Fasteners must be a minimum of 3 in. (8 cm) from any edge of a board.

Factory Prefabricated Metal:

Install factory prefabricated (Metal Counter Flashing/Gravel Stop Securement) (L-shaped) (J-shaped) metal securement in accordance with the manufacturer's instructions.

Perimeter Drainage:

When the perimeter drainage is used (i.e gutter edge detail), the perimeter edge securement must be perforated or spaced away from the edge and constructed from a minimum 18 gauge metal.

Securement Where Tongue and Groove Integrity Has Been Lost:

Breaks in tongue and groove integrity at all penetrations greater than 4 ft. (1.2 m), but less than 12 ft. (3.7 m) in any direction shall be secured with minimum 3 in. (7.6 cm) wide, 22 gauge strapping secured at maximum 12 in. O.C., or pavers. Breaks in tongue and groove integrity at all internal penetrations greater than or equal to 12 ft. (3.7 m) in any direction shall be secured in the same manner as the perimeter edge. Breaks in tongue and groove integrity caused by change of plain shall be reattached using 8 in. wide strapping, spanning the break using fasteners on 12 in. centers on each edge of the metal.

Installation of Fasteners:

Fasteners shall be placed in a pre-drilled hole, with the hole size specified by the fastener manufacturer. Drill-hole depth shall not be greater than 1.5 in. (3.8 cm). Hammer type drills must not be used. Fasteners shall be placed a maximum of 18 in. (46 cm) O. C. for attaching perimeter edge securement and a maximum 12 in. (30 cm) for attaching securement where tongue and groove integrity has been lost. Fasteners shall be placed a minimum of 3 in. (7.6 cm) from any board edges.

System 2

Metal Securement (Fig. 14, page 13 & 14)

Metal Edge Securement:

Install metal perimeter edge securement according to methods described above for System 1 securement with additional strap as follows:

Interior Metal Straps:

Attach securement straps running in the *long direction* (4 ft.) of the boards on the second and third row of whole boards in from the perimeter. Attach securement strap running in the *short direction* (2 ft.) of the boards, 3 ft. (91 cm) and 10 ft. (3m) from the perimeter and running across the entire roof. Every 10 ft. (3 m) thereafter, run strapping to the innermost strap (see Fig. 14).

Corner bracing/strapping must be placed at each corner.

System 3

Metal Securement (Fig. 16, page 15 & 16 & 17)

Metal Edge Securement:

Install metal perimeter edge securement as described under System 1 Securement above, and add the following interior securement.

Straps running in the *long direction* of the boards shall be attached to the 2nd, 4th, 6th, and 8th whole rows of boards in from the perimeter.

Straps running the *short direction* of the boards shall be attached starting at 6 ft. (1.8 m) from the perimeter and running every 10 ft. (3 m) thereafter along the entire roof. The straps shall attach the interior straps running in the *long direction* of the boards to the metal perimeter edge securement. Only the first two straps in from the perimeter, running in the short direction of the boards, need to go across the entire roof. The other straps proceed only as far as the inner most straps running in the long direction.

For further information, consult T. CLEAR CORP. Technical Data Sheet 4.3.2.

Figure 10 — System 1 Strapping Securement

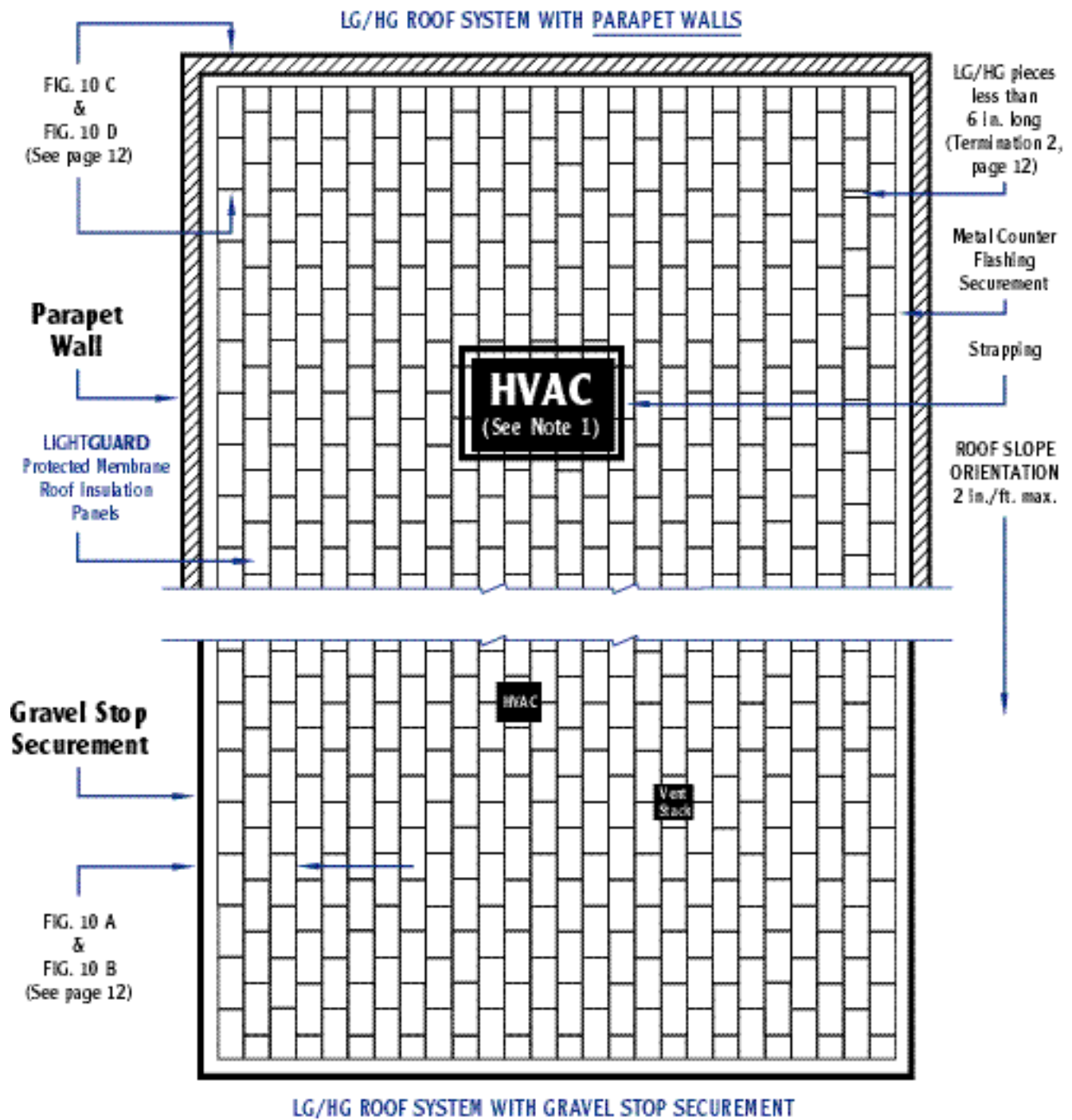

- NOTES:**
1. All penetrations larger than 4 ft. require securement by metal straps or concrete pavers.
 2. All interior metal strapping to be 22 ga. x 3 in. wide Galvalume, Zincalume or Stainless Steel.
 3. Mechanically fasten strapping and perimeter per T. CLEAR CORP. Technical Data Sheet 4.3.2.
 4. Loose-applied single ply membranes must meet requirements set by T. CLEAR CORP. Technical Data Sheet #20.

Figure 10A, 10B, 10C, 10D — System 1 Strapping Securement

Fig. 10A

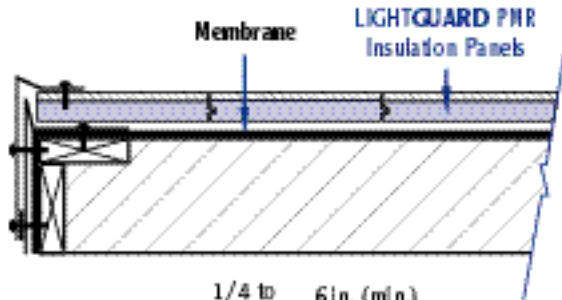

Detail Fig. 10A

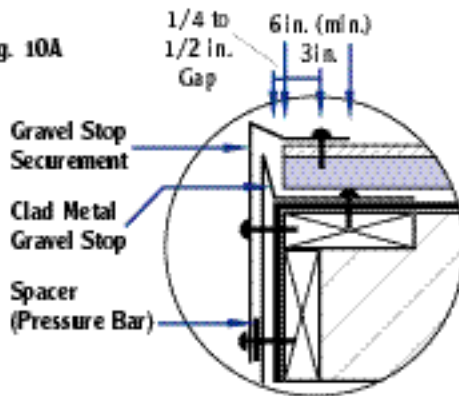
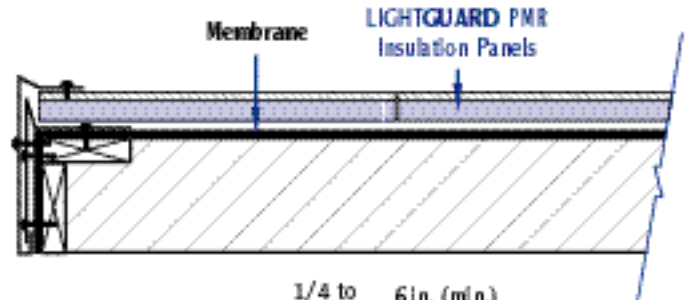
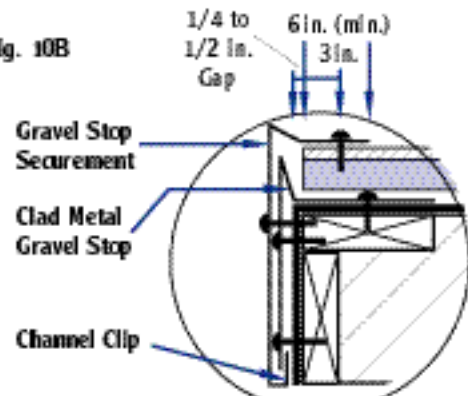

Fig. 10B



Detail Fig. 10B



TERMINATIONS

- 1. LONG EDGE (4 ft.) of LG/HG toward edge of building or wall:** The tongue and groove integrity must be maintained to the edge securement. The smallest edge piece shall be 6 in. wide or wider, with a tongue or groove to join the field boards.
- 2. SHORT END (2 ft.) of LG/HG toward edge of building or wall:** Pieces less than 6 in. long shall be placed in the array, usually 6 ft. to 10 ft. from edge of building.

Fig. 10C

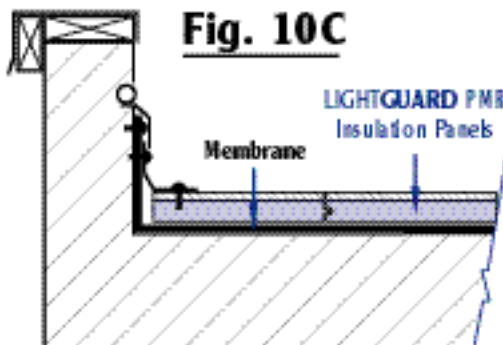

Detail Fig. 10C

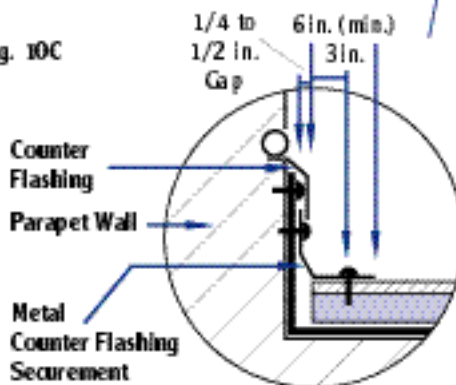
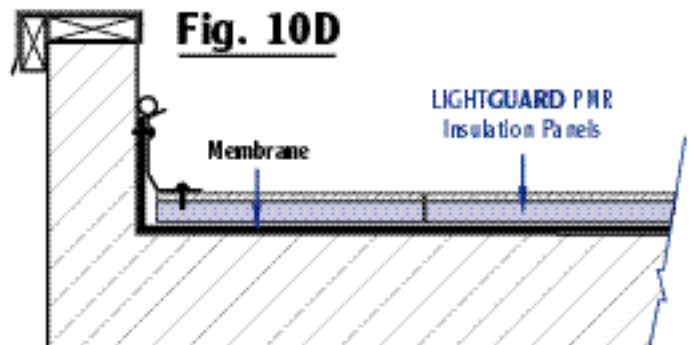

Fig. 10D



Detail Fig. 10D

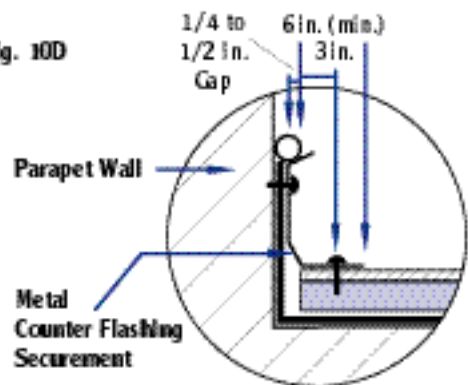
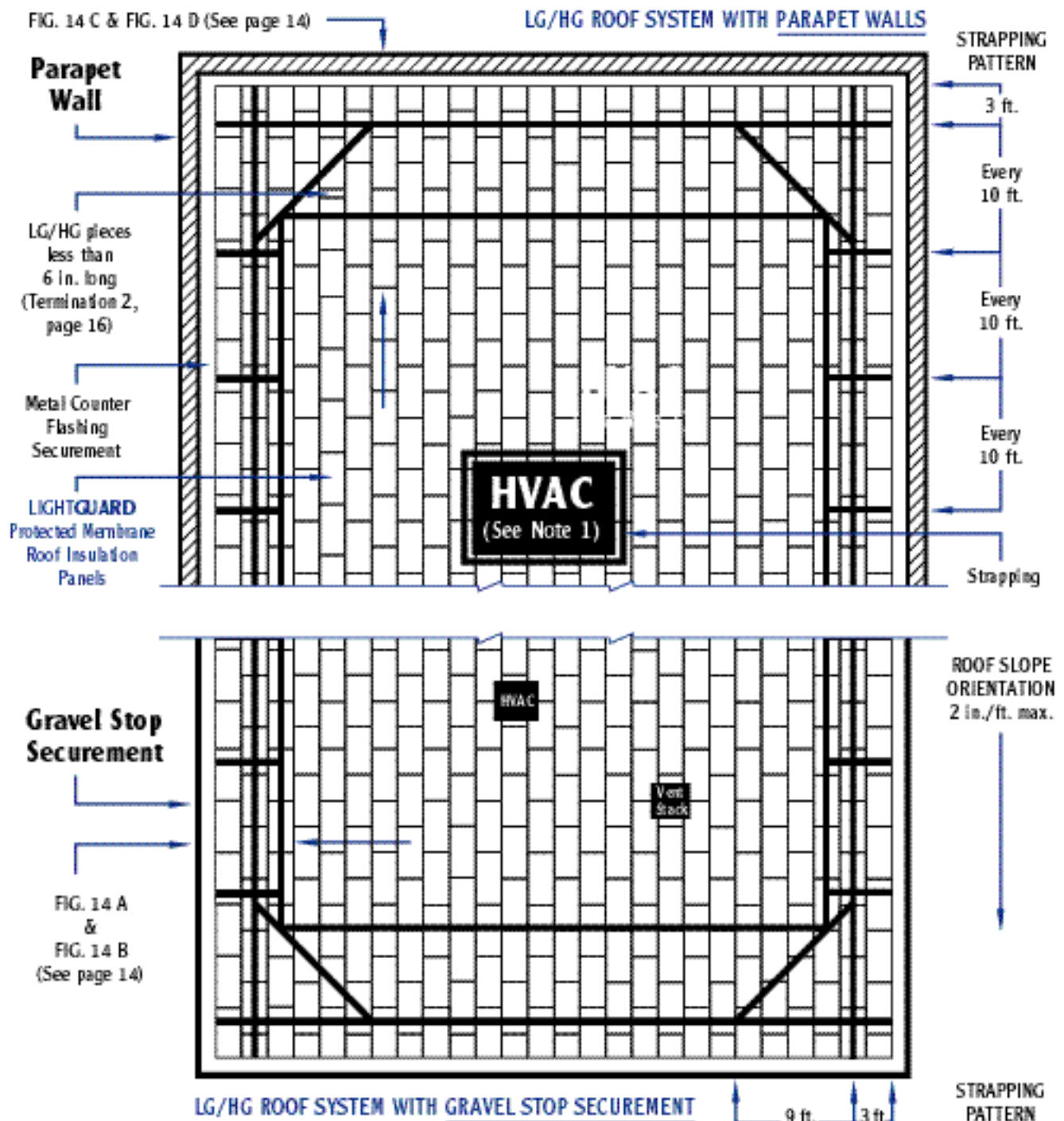
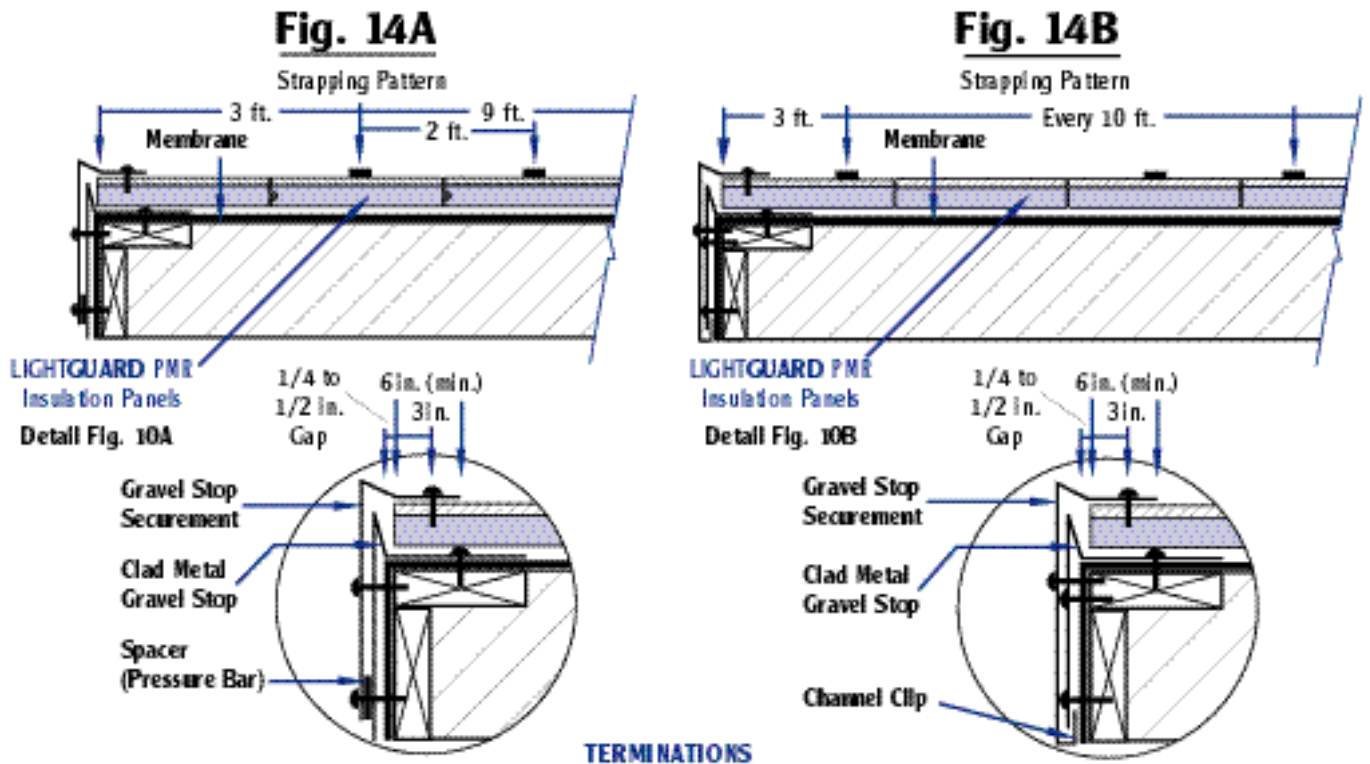

Figure 14 — System 2 Strapping Securement



- NOTES:**
1. All penetrations larger than 4 ft. require securement by metal straps or concrete pavers.
 2. All interior metal strapping to be 22 ga. x 3 in. wide Galvalume, Zincolume or Stainless Steel.
 3. Mechanically fasten strapping and perimeter per T. CLEAR CORP. Technical Data Sheet 4.3.2.
 4. Loose-applied single-ply membranes must meet requirements set by T. CLEAR CORP. Technical Data Sheet #20.
 5. Internal metal strapping layout is specific only to the direction of the boards.
 6. As an alternative to metal strapping, the pavers may be adhered to the mortar surface of the LIGHTGUARD using approved adhesive.

Figure 14A, 14B, 14C, 14D — System 2 Strapping Securement



TERMINATIONS

1. **LONG EDGE** (4 ft.) of LG/HG toward edge of building or wall: The tongue and groove integrity must be maintained to the edge securement. The smallest edge piece shall be 6 in. wide or wider, with a tongue or groove to join the field boards.
2. **SHORT END** (2 ft.) of LG/HG toward edge of building or wall: Pieces less than 6 in. long shall be placed in the array, usually 6 ft. to 10 ft. from edge of building.

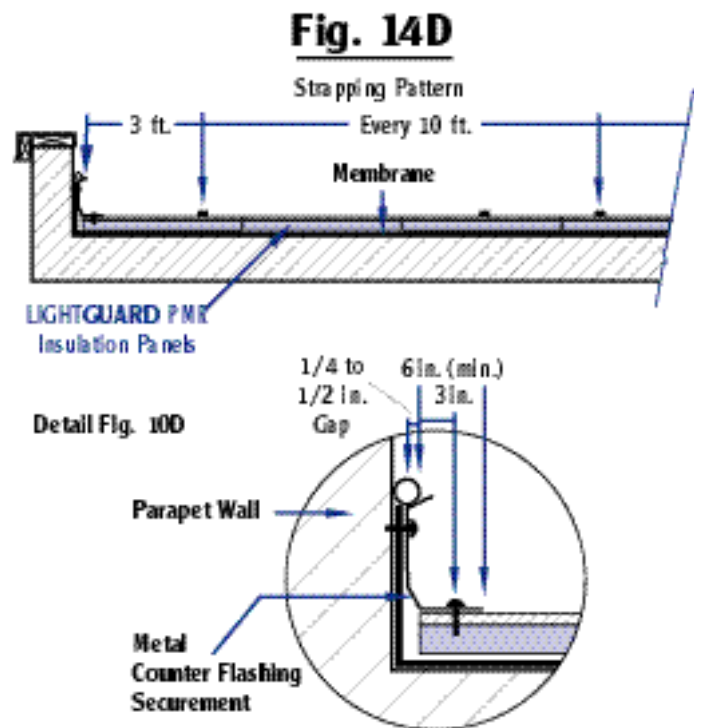
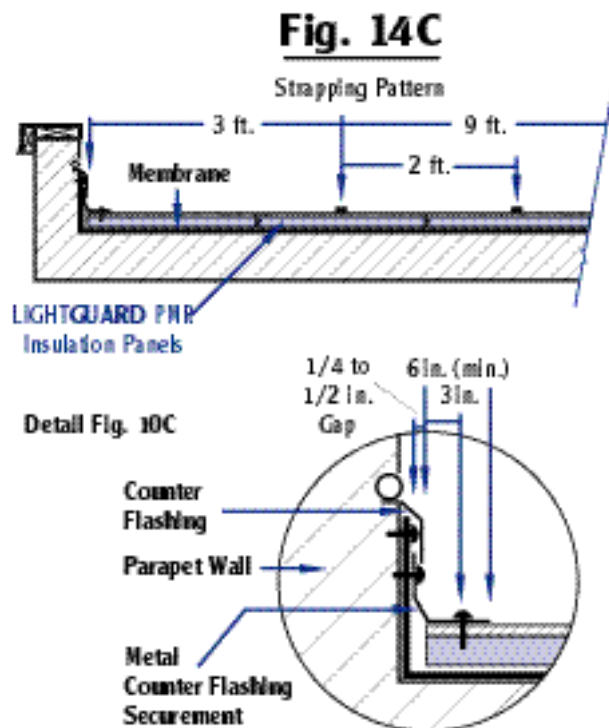
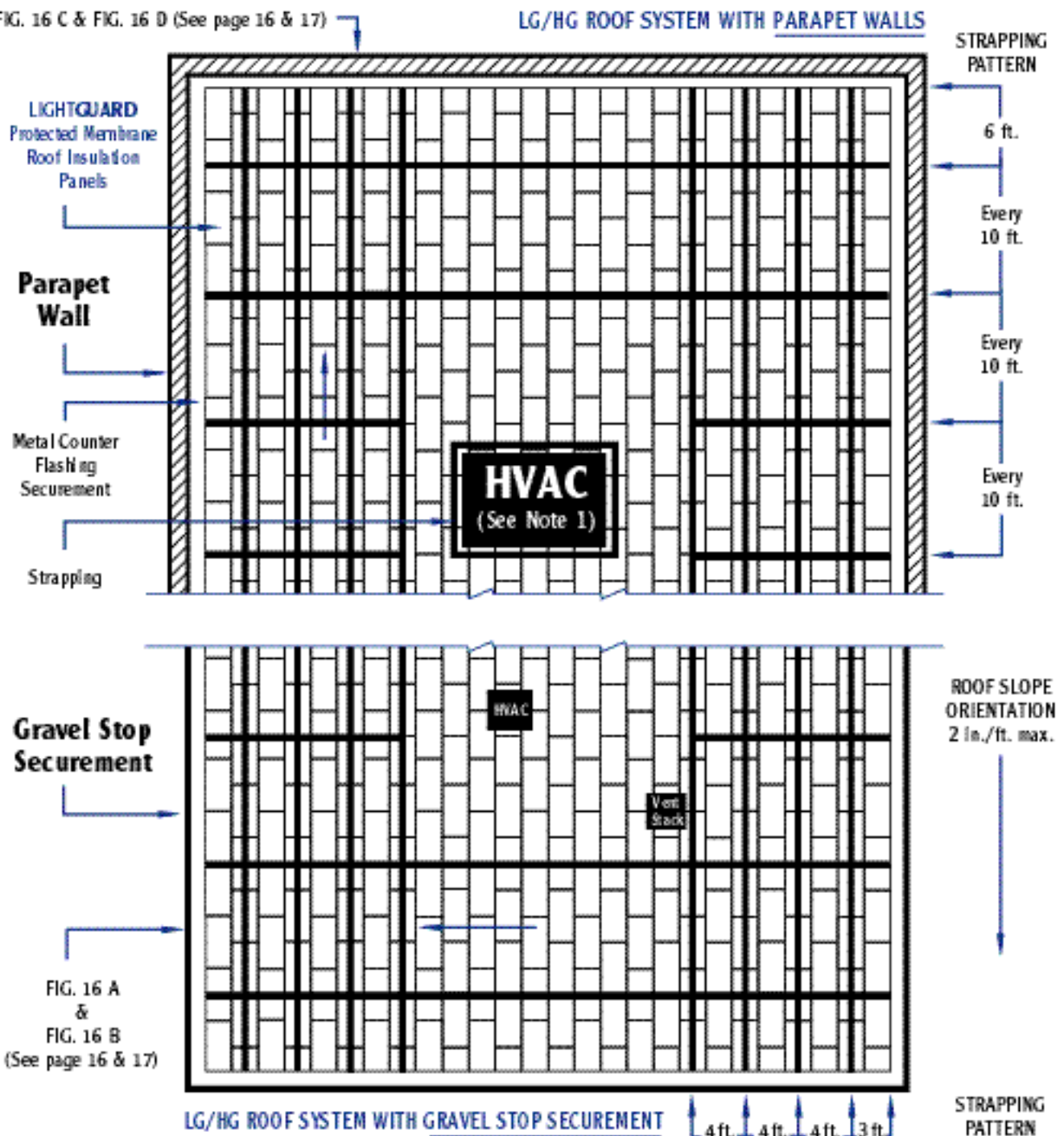

Figure 16 — System 3 Strapping Securement

FIG. 16 C & FIG. 16 D (See page 16 & 17)



- FIG. 16 A & FIG. 16 B (See page 16 & 17)
- NOTES:**
1. All penetrations larger than 4 ft. require securement by metal straps or concrete pavers.
 2. All interior metal strapping to be 22 ga. x 3 in. wide Galvalume, Zincolume or Stainless Steel.
 3. Mechanically fasten strapping and perimeter per T. CLEAR CORP. Technical Data Sheet 4.3.2.
 4. Loose-applied single-ply membranes must meet requirements set by T. CLEAR CORP. Technical Data Sheet #20.
 5. Internal metal strapping layout is specific only to the direction of the boards.

Figure 16A, 16C — System 3 Strapping Securement

Fig. 16A

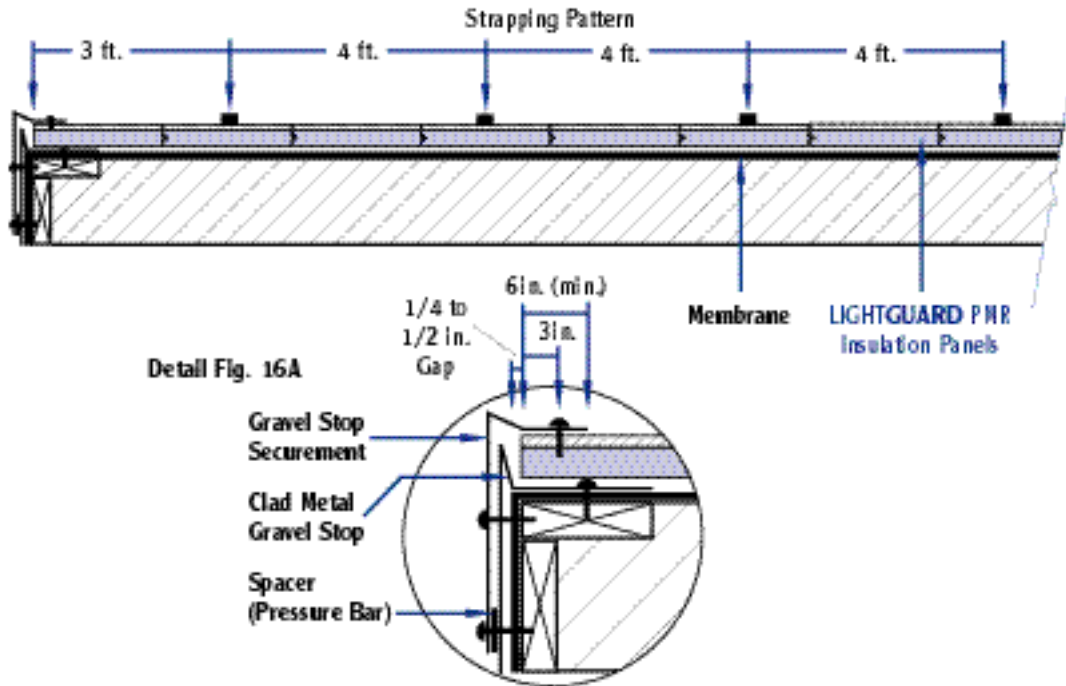

TERMINATIONS

1. **LONG EDGE (4 ft.) of LG/HG toward edge of building or wall:** The tongue and groove integrity must be maintained to the edge securement. The smallest edge piece shall be 6 in. wide or wider, with a tongue or groove to join the field boards.

Fig. 16C

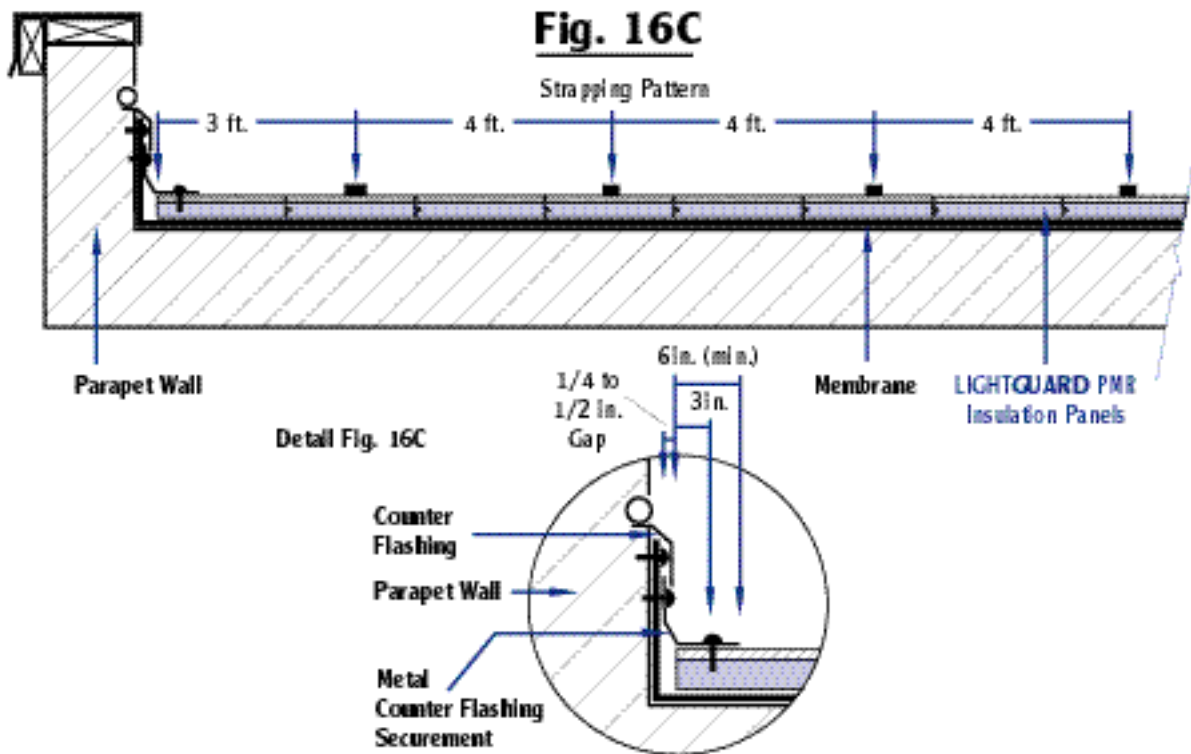
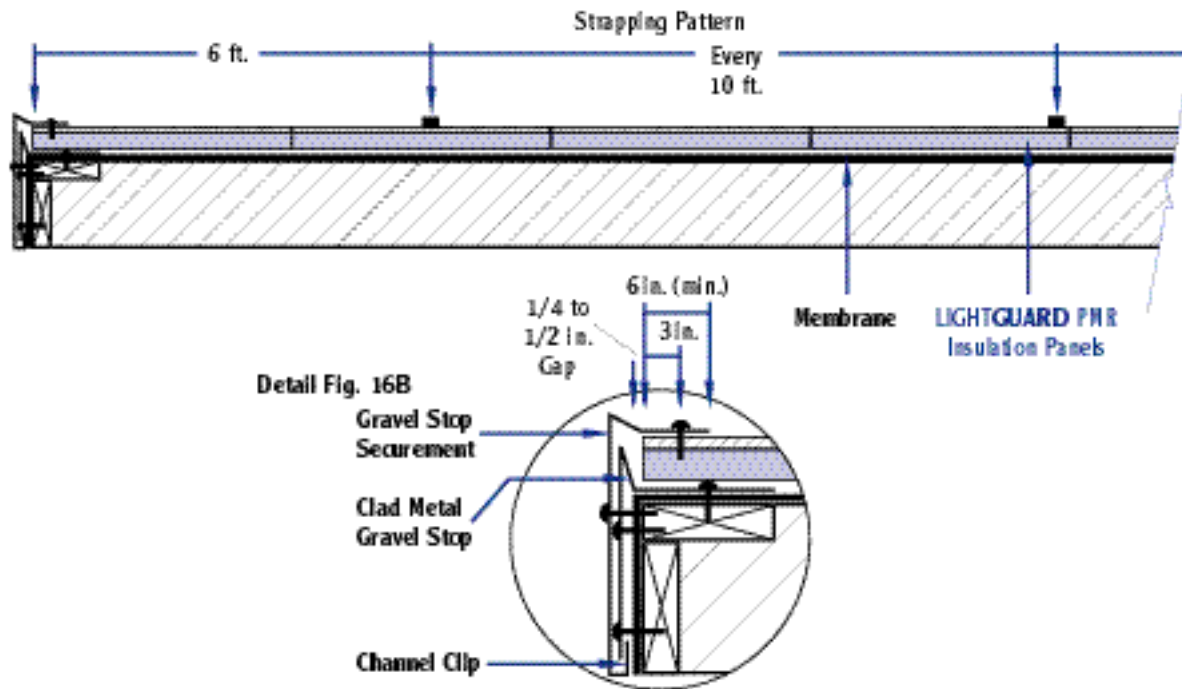

Figure 16B, 16D — System 3 Strapping Securement

Fig. 16B



TERMINATIONS

2. **SHORT END (2 ft.) of LG/HG toward edge of building or wall:** Pieces less than 6 in. long shall be placed in the array, usually 6 ft. to 10 ft. from edge of building.

Fig. 16D

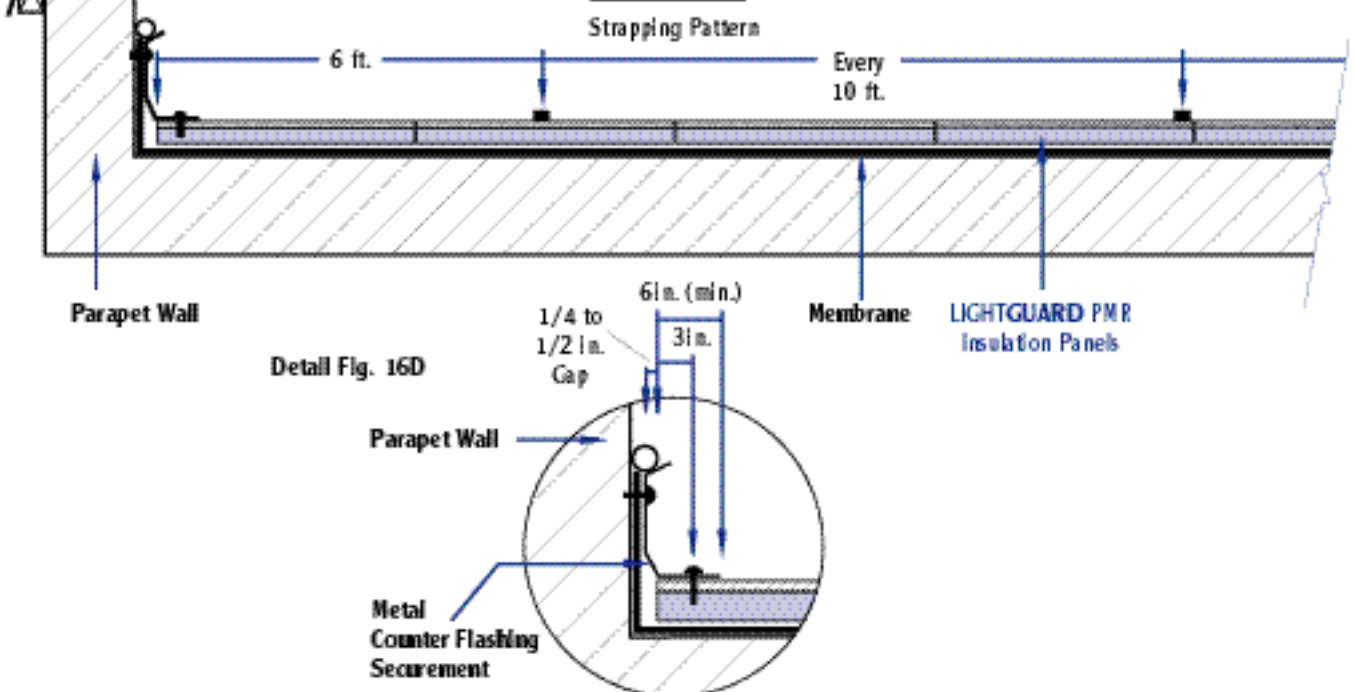

LIGHTGUARD® & HEAVYGUARD® System Tables Paver Securement

System 1 Paver Securement

Adhered Membranes:

Securement shall be a single row of nominal pavers, 2 in. (5.1 cm) x 8 in. (20 cm) x 16 in. (41 cm), weighing a minimum of 19 lbs. each, (8.8 Kg) laid with their long edge perpendicular to the roof perimeter. (**Note:** 8 in. by 16 in. pavers are for wind zones of 100 mph or less).

Loose-laid membranes and multiple layered foam installations:

Securement shall be a single row of nominal 2 in. (5.1 cm) x 2 ft. (61 cm) x 2 ft. (61 cm) pavers, weighing a minimum of 88 lbs. (40 Kg) or two rows of nominal 2 in. (5.1 cm) x 8 in. (20 cm) x 16 in. (41 cm) pavers, weighing a minimum of 19 lbs. (8.8 Kg) each, laid with their long edge perpendicular to the roof perimeter. (**Note:** 8 in. by 16 in. pavers are for wind zones of 100 mph or less).

Paver placement:

The pavers shall be placed in continuous rows butted together at all perimeters, openings, or penetrations greater than 4 ft. (1.2 m) long. When the 4 ft. (1.2 m) long direction of the board runs parallel to the perimeter, pavers shall be placed with their outside edge centered on the perimeter board (covering the first board joint). When the 2 ft. (61 cm) direction of the board runs parallel to the perimeter, pavers shall be placed in from the perimeter at least 12 in. (30.5 cm) and no more than 18 in. (45 cm).

The height of the gravel stop or parapet shall extend above the finished height of the paver in all cases.

System 2 Paver Securement

Install 2 in. x 2 ft. x 2 ft. pavers weighing a minimum of 88 lbs. (40kg) following the requirements as described for System 1 above. Pavers shall be adhered to the surface of the boards by applying two parallel 3/8 in. continuous beads of Vulkem Sealant 116, or approved equal, to the surface of the LIGHTGUARD® boards before placing the pavers. A second row of similar pavers shall be installed as above centered 6 ft. from the perimeter.

Paver Metal Strap Mix:

Install the first row of pavers as above, install the interior metal as described under System 2 Metal Securement.

System 3 Paver Securement

Install 2 in. x 2 ft. x 2 ft. pavers weighing a minimum of 88 lbs. (40kg) following the requirements as described for System 1 above. Pavers shall be adhered to the surface of the boards by applying two parallel 3/8 in. continuous beads of Vulkem Sealant 116, or approved equal, to the surface of the LIGHTGUARD boards before placing the pavers. A second row of similar pavers shall be installed as above adjacent to the first row. A third row of similar pavers shall be installed as above centered at 9 ft. from the roof perimeters. A fourth row of similar pavers shall be installed as above centered at 13 ft. from the roof perimeters.

Paver Metal Strap Mix:

Install the first row of pavers as above, install the interior metal as described under System 3 Metal Securement.

For further information, consult T. CLEAR CORP. Technical Data Sheet 4.3.2.

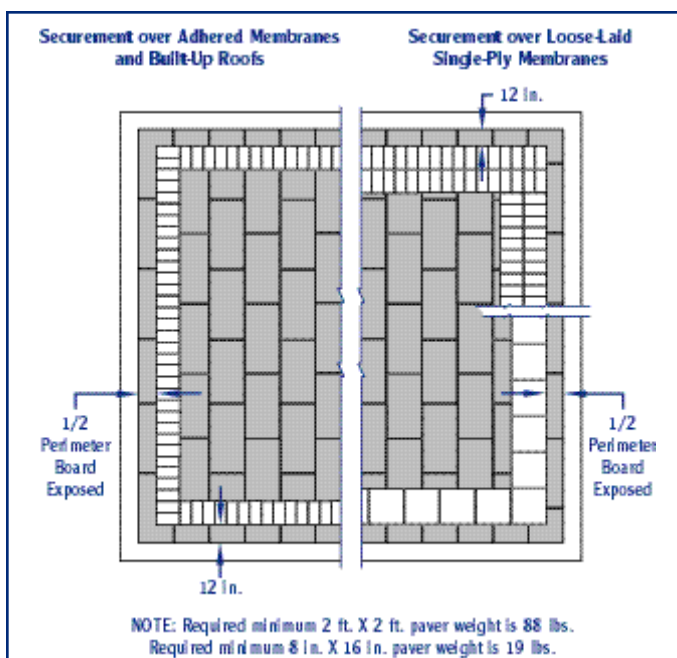

References

The information presented is based on the following:

- 1) Extensive wind testing of ballasted roofing systems at the National Research Council of Canada.
- 2) ANSI/SPRI-RP4 Wind Design Guide for Ballasted, Single-ply Roofing Systems.
- 3) UL 1897, Roofing Systems Uplift Resistance R14358.
- 4) RIEI Protected Membrane Roofing course manual.

®LIGHTGUARD and HEAVYGUARD are registered trademarks of T. Clear Corporation.

NOTICE: T. CLEAR CORP. believes the information and recommendations herein to be accurate and reliable as of May, 2005. However, since any assistance furnished by T. CLEAR CORP. with reference to the proper use and disposal of its products is provided without charge, and since use conditions and disposal are not within its control, T. CLEAR CORP. assumes no obligation or liability for such assistance and does not guarantee results from use of such products or other information herein; no warranty, expressed or implied, is given nor is freedom from any patent owned by T. CLEAR CORP. or others to be inferred. Information herein concerning laws and regulations is based on U.S. federal laws and regulations except where specific reference is made to those of other jurisdictions. Since use conditions and governmental regulations may differ from one location to another and may change with time, it is the Buyer's responsibility to determine whether T. CLEAR CORP.'S products are appropriate for Buyer's use, and to assure Buyer's workplace and disposal practices are in compliance with laws, regulations, ordinances, and other governmental enactments applicable in the jurisdiction(s) having authority over Buyer's operations.



3255 Symmes Road
Hamilton, OH 45015
1-800-544-7398

www.tclear.com

©2005 T. Clear Corp.