

NEW from
Marathon!



Retrofit Ring and Dome

**Versatile,
Easy & Quick
Replacement
for Broken
or Missing
Roof Drain
Domes & Rings**

- **Maximum
Drainage**
- **Strong, Cast
Aluminum**
- **Low Profile**
- **Bolt Down
Security**

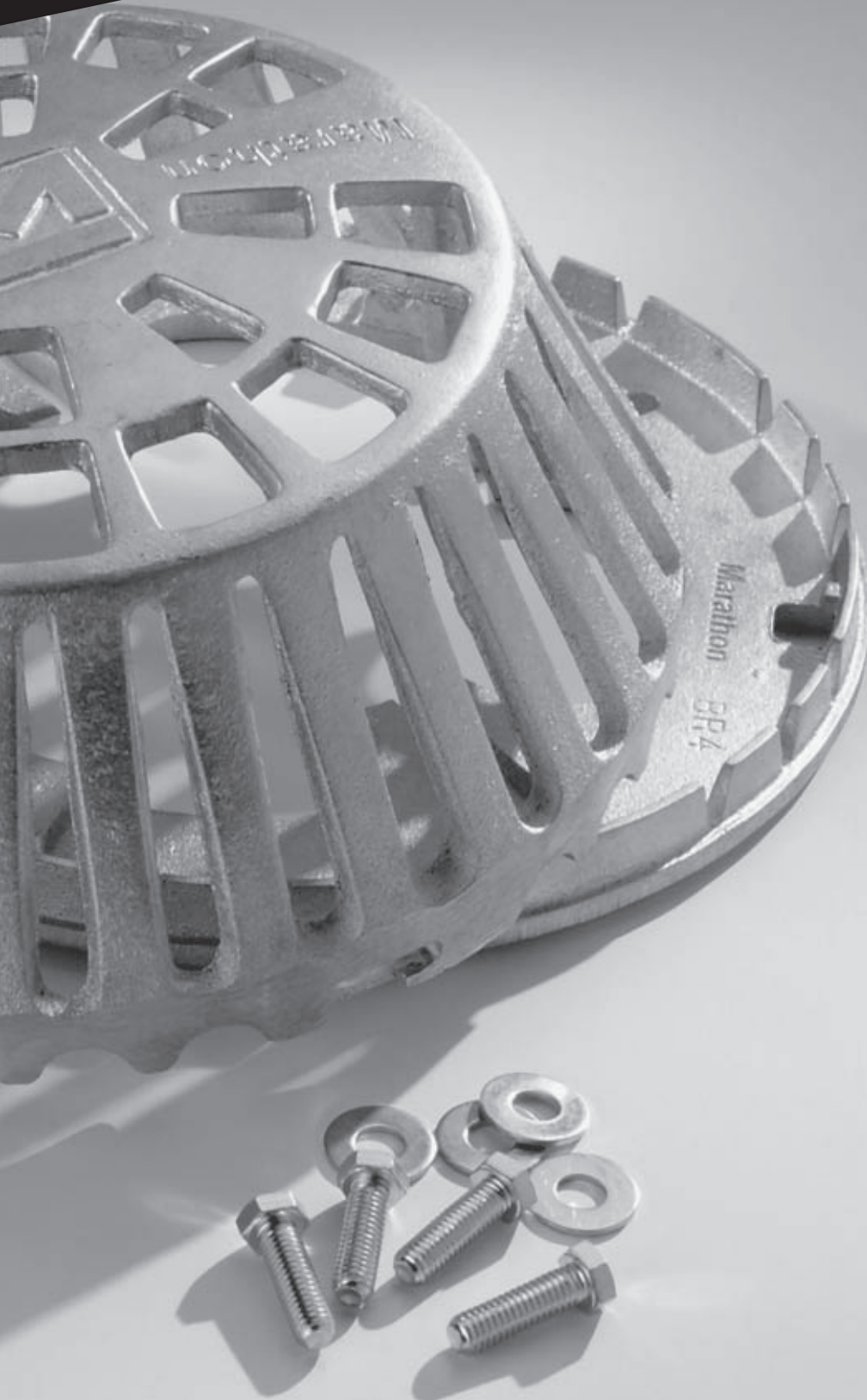

Retrofit Ring & Dome

A versatile, easy and quick replacement for broken or missing roof drain domes or rings.

Ring is suitable to most standard four bolt pattern styles.

Key Feature:

Aligning "Open V" channels of the Retrofit Base Ring to the scallop openings of the Retrofit Dome creates optimum drainage.

Ring Features:



Strong Cast Aluminum with **four pairs of bolt-down tines** to align with most old drain bolt patterns that range from 6½" to 11¾"

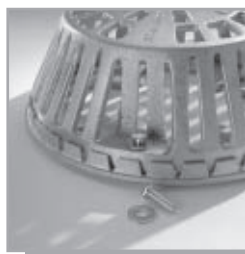

Tapped, extra strength lugs to accept the 2 hold-down bolts of the dome, allowing it to be firmly fixed in place to secure attachment

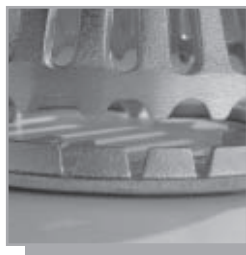

Shallow thickness of the ring creates a low profile fit to the deck to reduce barriers of drainage

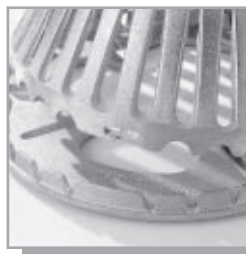

Two opposite, slotted channels on the Dome that align with the Ring openings for "Twist-in-Place" attachment.



26 "V" channels cut into the ring perimeter to facilitate drainage.

**BEST DESIGN
AVAILABLE!**

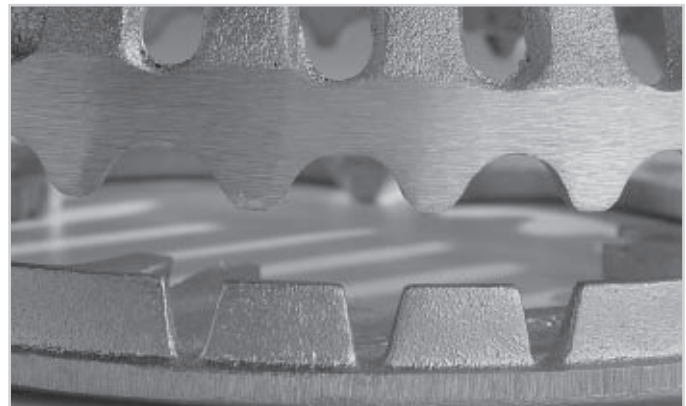

Broken Drain Rings? Missing or Broken Strainer Domes?

It's always hard to find replacement units that fit properly on old roof drain openings.

Now you can replace old or broken drain rings & domes with Marathon's Retrofit Ring & Dome System.

The Retrofit Ring & Dome will match up to most old style existing drains.

Designed for re-roofing applications when a clamping ring is important to secure single-ply and two ply membranes in waterproof roof systems.

By aligning Marathon's Retrofit Ring over the existing bolt holes in the old drain body and installing the new hold-down bolts with washers, the difficult problem of replacing matching domes is resolved.

Ring and Dome may be purchased separately or in combination. Together they offer a positive fit with locked in and bolt-down features.

Dome Features:



Broad 12" diameter dome for maximum drainage area



Twist-n-lock attachment, plus 2 bolts to secure to base ring. Vandal Resistant



Low profile 5" overall height designed for stability, strength and handsome profile

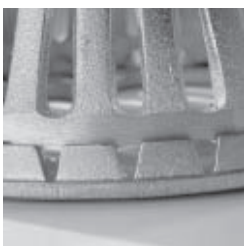

Multiple openings matched to the base ring "V" grooves to maximize drainage



Specifications:

Strainer Elevation

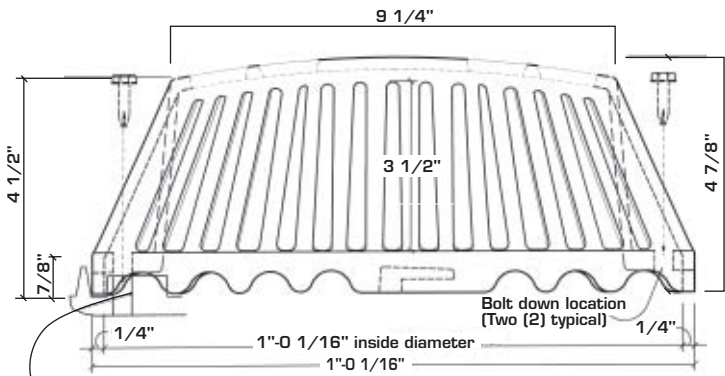

Line represents section of base ring showing location of 5/16" tapped hole for bolt down of strainer.

Bolt Down Base Ring

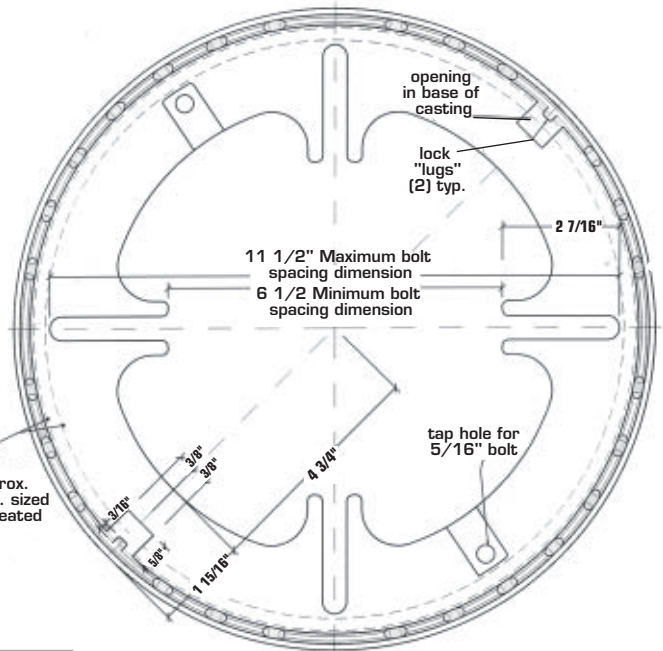

Represents approx. location of max. sized strainer when seated in base ring.



Strainer shown with expandable scissors.

Marathon designs and manufactures a complete line of drains, vents & breathers

Additional wide selection of strainers available in aluminum, cast iron and plastic. Sizes range from 2" to 14" diameter. Many styles can be outfitted with expandable scissors to make positive attachment to drain pipe.



TOLL FREE: 1-800-828-8424

3310 N. Benzing Road • Orchard Park, NY 14127-1538

PH: 716-332-7673 • FAX: 716-332-7676

Website: <http://www.marathondrains.com>

E-Mail: mrp@marathondrains.com