

COPPER RETROFIT ROOF DRAINS

COPPER-TITE ROOF DRAINS

- FOR RE-ROOFING INSTALLATIONS
- FITS INSIDE EXISTING DRAIN • SIZES 2" TO 10"
- CREATES SEAL FOR WATER BACK-UP PROTECTION



COPPER-TITE™

FEATURES

- A retro-fit insert copper drain
- Seals securely within existing pipe
- Prevents water back-up problems by sealing side wall gaps with expandable waterproof tape
- Simple and quick to install, just peel off tape
- COPPER for reliable long life
- TITE for secure waterproof fit
- Fits drains 2" (51mm) to 10" (203mm)

COPPER-TITE features a 2" (51mm) wide band of high density expanding foam tape impregnated with asphalt which is factory applied in a compressed state around the drain outlet.

COPPER-TITE sealant tape is designed to expand to approximately four times its compressed thickness. Just prior to inserting the COPPER-TITE drain the installer removes the exterior restraining tape and immediately sets the retro drain in place. The released tape gradually expands to fill the space between the COPPER-TITE drain and the existing drain sleeve making the connection watertight.

COPPER-TITE sealant tape expands more slowly in cold temperatures. When heat is applied to the inside of the outlet the sealant tape expands more rapidly.

Should the tape expand too much before inserting the COPPER-TITE drain, simply recompress the tape by hand and then insert the drain.

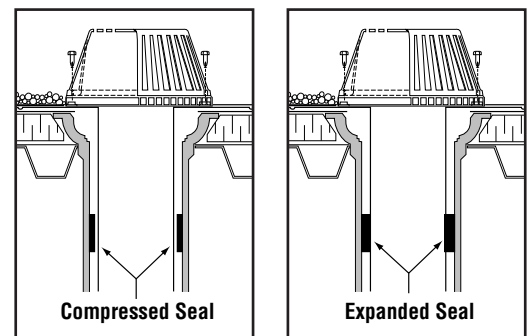

INSTALLATION

COPPER-TITE Drains are an economical answer to potential water back-up problems. They are designed to fit neatly into old existing drains in a retro-fit application.

3 EASY STEPS TO INSTALL:

STEP 1 Inspect the old drain for possible cracks and for a smooth clean surface. Scrape away old asphalt and dirt. Use a heat gun to soften old asphalt and to achieve a relatively dry surface, if necessary.

STEP 2 Test the size of the new **COPPER-TITE** drain by inserting it into the now clean original drain before

removing the compression tape. With the correct size of **COPPER-TITE** now confirmed, remove the drain, release the compression tape and promptly re-insert the **COPPER-TITE** drain. The tape gradually expands to fill the space surrounding the outlet of the new **COPPER-TITE** there-by creating the back-up seal feature.

STEP 3 Flash in the drain flange according to methods determined by the membrane manufacturer and/or the roofer using the clamping ring, if applicable. Attach the strainer dome.

OPTIONS & SPECIFICATIONS

STRAINER DOMES: Plastic is standard, Cast Iron is optional.

FLANGE OPTIONS: Plain finish -N/C • Asphalt primed finish - N/C • PVC coating is extra

COPPER-TITE™ with expanding anti back-up seal feature

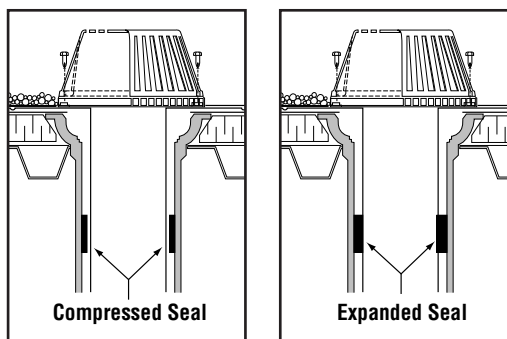

Drain Pipe Size	Coppertite Straight (CTS)			Coppertite Straight w/ Clamping Ring					
	Cat #	Specification	Flange Size	Cat #	Specification	Flange Size	Cat #	Specification	Flange Size
2" 51mm	CTS29	175 x 9 (SF)*	14" 356mm	CTS29CR	175 x 9CR (LF)**	18" 457mm	CTS29CR(E)	175 x 9CR (SF)*	14" 356mm
3" 76mm	CTS39	275 x 9 (SF)*	14" 356mm	CTS39CR	275 x 9CR (LF)**	18" 457mm	CTS39CR(E)	275 x 9CR (SF)*	14" 356mm
4" 102mm	CTS49	375 x 9 (SF)*	14" 356mm	CTS49CR	375 x 9CR (LF)**	18" 457mm	CTS49CR(E)	375 x 9CR (SF)*	14" 356mm
5" 127mm	CTS59	475 x 9 (SF)*	18" 457mm	CTS59CR	475 x 9CR (LF)**	18" 457mm			
6" 152mm	CTS59	575 x 9 (SF)*	18" 457mm	CTS69CR	575 x 9CR (LF)**	18" 457mm			
8" 203mm	CTS89	775 x 9 (SF)*	18" 457mm	CTS89CR	775 x 9CR (LF)**	18" 457mm			

* (SF) Small Flange

** (LF) Large Flange

Drain Outlets may be ordered extended by 6 inches.



Quality Products for Professional Roofers