

- EAKM 32-K** (metal levers with porcelain indices)
- EAKM 36-K** (white porcelain levers with metal indices)
- EAKM 38-K** (black porcelain levers with metal indices)

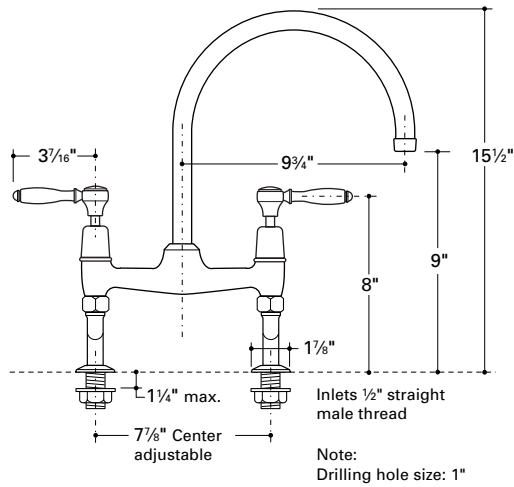

## INSTALLATION GUIDELINES

- Use only a protected, smooth-jawed, or strap wrench on any finished surface.
- DO NOT use putty on deck fittings. Upper and lower washers are provided.
- Accepts standard supply tubes or stainless steel flex supplies.
- Check for leaks.
- After installation, unscrew and remove the aerator assembly. Carefully open the hot and cold valves fully to flush out any debris in the supply lines. Once the lines have been flushed, close the valves and reinstall the aerator assembly.
- For servicing valve stem: Unscrew the cover and pull off the handle and cover together: Cover should be hand tight.
- If further assistance is required, please contact Product Support at 1-800-927-2120 (8am–7pm EST).

### EAKM 32-K (metal lever with porcelain index)

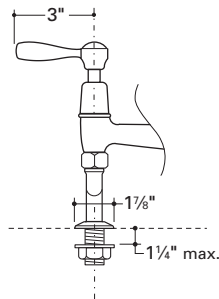

These guidelines have been prepared for the professional contractor to aid in the installation of:  
**EASTON DECK MOUNTED KITCHEN MIXER**  
**(EAKM32-K/EAKM36-K/EAKM38-K)**

All dimensions are based on original specifications and are subject to change and variation. Please consult your Design Associate for current specifications.

## CARE AND CLEANING

**The lustrous finish on your fitting or fixture should be treated with care. Improper handling or cleaning will damage the surface of any finish and void the warranty.**

To clean the finish, wipe gently with a soft damp cloth and then with a soft dry towel. A mild soap solution can be used for daily cleaning. THE USE OF UNAUTHORIZED POLISHES, ABRASIVE CLEANERS, SOLVENTS, AMMONIA-BASED PRODUCTS, OR ACID BASED CLEANERS MAY DAMAGE THE FINISH AND WILL VOID THE WARRANTY.

Water contains lime and other minerals that are deposited after the water has evaporated. You can prevent deposits from forming by always wiping the fitting dry after use.

**In addition to the aforementioned care instructions, the following points are specific to certain finishes or products only. Always read and follow the instructions when using any cleaning or polishing products.**

### NON-METAL TUBS

In addition to mild soap and water, a non-abrasive basin tub and tile cleaner is recommended for regular cleaning and disinfecting. The use of any other cleaners or disinfectants may alter the surface finish and void the warranty.

### WHIRLPOOL AND AIRTUB SYSTEMS

Jet Fresh whirlpool cleaning solution is recommended for maintaining waterways.

### ANTIQUED COPPER AND BRASS

Select Waterworks fittings and basins are offered in finishes that have been artificially weathered, creating a patina that will develop and change with time. In addition to mild soap and water, a natural citrus-based product may be used for regular cleaning. The use of any other cleaners or disinfectants may alter the surface finish and void the warranty. Please note that prolonged contact with certain items such as toothpaste, acidic fruits and vegetables, and wines will alter the surface finish. Also, the use of polishing agents will remove the patina and restore the metal to its original shine. Once removed, the patina will naturally redevelop with time.

### ARCHITECTURAL BRONZE

In addition to mild soap and water, a natural citrus-based product may be used for regular cleaning. The use of any other cleaners or disinfectants may alter the surface finish and void the warranty. Please note that prolonged contact with certain items such as toothpaste, acidic fruits and vegetables, and wines will alter the surface finish. Also, the use of polishing agents will remove the finish.

### CHINA, CERAMIC AND PORCELAIN

Do not use abrasive cleaners, as this will dull the surface finish. A non-abrasive basin tub and tile cleaner is recommended for regular cleaning and disinfecting. The use of any other cleaners or disinfectants may alter the surface finish and void the warranty.

### CHROME

In addition to mild soap and water, a non-abrasive basin tub and tile cleaner is recommended for regular cleaning and disinfecting. The use of any other cleaners or disinfectants may alter the surface finish and void the warranty. Cape Cod Polishing Cloths may be used for the occasional polishing. If you desire additional protection, the use of Faucet Brite will aid in protecting the surface finish from mineral deposits present in your water supply. This should be reapplied as necessary to continue protection.

### MATTE NICKEL, LUMIN AND GOLD

In addition to mild soap and water, a non-abrasive basin tub and tile cleaner is recommended for regular cleaning and disinfecting. The use of any other cleaners or disinfectants may alter the surface finish and void the warranty. Also, the use of polishing agents will remove the finish. If you desire additional protection, the use of Faucet Brite will aid in protecting the surface finish from mineral deposits present in your water supply. This should be reapplied as necessary to continue protection.

### NICKEL

In addition to mild soap and water, a non-abrasive basin tub and tile cleaner is recommended for regular cleaning and disinfecting. The use of any other cleaners or disinfectants may alter the surface finish and void the warranty. Cape Cod Polishing Cloths may be used for the occasional polishing. The use of any other polishing agents will remove the finish and void the warranty. If you desire additional protection, the use of Faucet Brite will aid in protecting the surface finish from mineral deposits present in your water supply. This should be reapplied as necessary to continue protection.

### SILVER

Fittings offered in a silver finish will tarnish with age. This finish may be restored to its original luster by using Faucet Brite or a non-abrasive silver polish. This should be reapplied as necessary to continue protection. Faucet Brite will also help to prolong the time between regular polishing.

### UNLACQUERED BRASS AND COPPER

Items purchased in the unlacquered brass and copper finishes will change with time as they develop a natural patina. The original shine can be restored using Faucet Brite or an appropriate polishing compound. If you desire additional protection, the use of Faucet Brite will aid in protecting the surface finish from mineral deposits present in your water supply and prolong the time between regular polishing. This should be reapplied as necessary to continue protection.

## WARRANTY

### LIMITED LIFETIME MECHANICAL WARRANTY:

Waterworks warrants to the initial purchaser all plumbing and accessory products sold by Waterworks, which are installed in a residence to be used in a residential application, to be free from manufacturing defects in materials and workmanship for as long as the purchaser continues to own and maintain the residence where the products are initially installed.

### FIVE-YEAR FINISH WARRANTY:

Waterworks warrants to the purchaser the finish of all plumbing and accessory products sold by Waterworks, which are installed in a residence to be used in a residential application, to be free from manufacturing defects in materials and workmanship for a period of five years from installation of the products. Waterworks must receive notice of any warranty claim within the five-year warranty period.

### REPAIR OR REPLACEMENT:

If within the applicable warranty period the covered products shall be proved to the satisfaction of Waterworks to be defective, Waterworks will repair or replace such products, at its expense (provided that such repair or replacement shall not include installation costs). Waterworks' obligation shall be limited to such repair and replacement and shall be conditioned upon Waterworks' receiving notice of any alleged defect within the applicable warranty period. [Purchaser shall be responsible for all shipping charges for returned products.]

### LIMITATIONS ON WARRANTY COVERAGE:

The warranties set forth above shall be extended only to the purchaser and do not apply to any purchaser where the products are used for commercial applications and usage. Furthermore, the warranties do not cover installation or any other labor charges and do not apply to:

- (i) products which have been repaired, altered or modified in any way by purchaser or any person other than Waterworks or not using original Waterworks spare parts, unless previously authorized in writing by Waterworks;
- (ii) products which have not been installed, used, maintained or stored in accordance with the instructions provided to purchaser by Waterworks;
- (iii) products which have been used for purposes other than or in a manner contrary to their intended and normal use;
- (iv) products which have been damaged as a result of misuse, negligence, freezing, accident or faulty installation or maintenance; and
- (v) products damaged by the effects of dirt, salt water air, hard water, limescale, or abrasive or aggressive cleaners. If the normal life span of any product is shorter than the applicable warranty period, the warranty shall apply only during the period of such shorter life span.

### NOTICE OF WARRANTY CLAIMS:

For all warranty claims please call Waterworks Product Support at 800-927-2120, or write to Waterworks Product Support at 60 Backus Avenue, Danbury, Connecticut 06810.

**The warranties provided herein are conveyed only to the purchaser of products sold by Waterworks after January 1, 2000, and installed in a residential application.**

**Except as specifically set forth above, Waterworks does not make any other warranty, express or implied, including without limitation, any implied warranty of merchantability or fitness for a particular purpose. In no event shall Waterworks be liable to any person or entity for any indirect, special, incidental or consequential damages or loss (including damages for loss of business, loss of profits, or the like), whether based on breach of contract, tort (including negligence), product liability or otherwise, even if it has been advised of the possibility of such damages. Waterworks' liability on any claim of any kind, including negligence, shall in no case exceed the contract price paid by the purchaser for the product claimed to be defective or unsuitable.**