



BRETFORD

PRESENTATION ENVIRONMENTS®

HOSPITALITY CART

Assembly Instructions

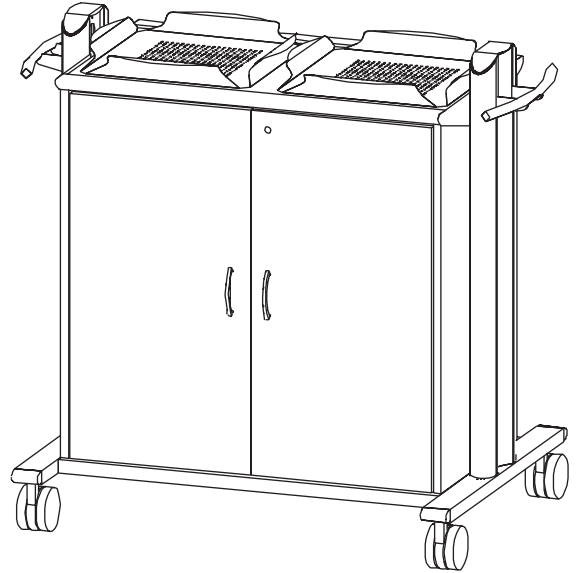

PARTS LIST

Qty	Description
1	Right Leg Assembly
1	Left Leg Assembly
1	Bottom Shelf
1	Right Side Panel
1	Left Side Panel
1	Wood Top Rail
1	Back Panel
1	Top Shelf
2	Cart Handles
1	6 Outlet Electrical Unit
2	Adjustable Shelves
2	Door Baskets
1	Right Insert Panel
1	Left Insert Panel
2	Serving Trays
3	Rubber Mats

HARDWARE LIST

Ref	Qty	Description
AA	12	1/4-20 x 5/8" Truss Head Screws
BB	16	5/16-18 x 5/8" Hex Head Screws
CC	22	#6 x 5/8" Flat Head Phillips Screws
DD	2	Cam Locks
EE	2	Locking Screws
FF	2	Wood Dowels
GG	8	#10-32 x 1/2" Combo Truss Screws
HH	8	#10-32 x 1" Combo Truss Screws
II	8	Collar Pins
KK	2	#6 x 5/8" Phillips Pan Screws
LL	4	M4 x 23mm Handle Screws
MM	2	Felt Pads
NN	8	#8 x 1/2" Phillips Truss Screws
OO	2	10-32 x 1/2" Brass Knob Screws
PP	10	Rubber Bumpers
	2	4" Twinwheel Casters w/ Lock
	2	4" Twinwheel Casters w/o Lock
	4	Hinge Plates
	4	Hinges
	4	Shim Plates
	1	Strike Plate (Left Door)
	1	Lock w/ Key (Right Door)
	2	Door Handles

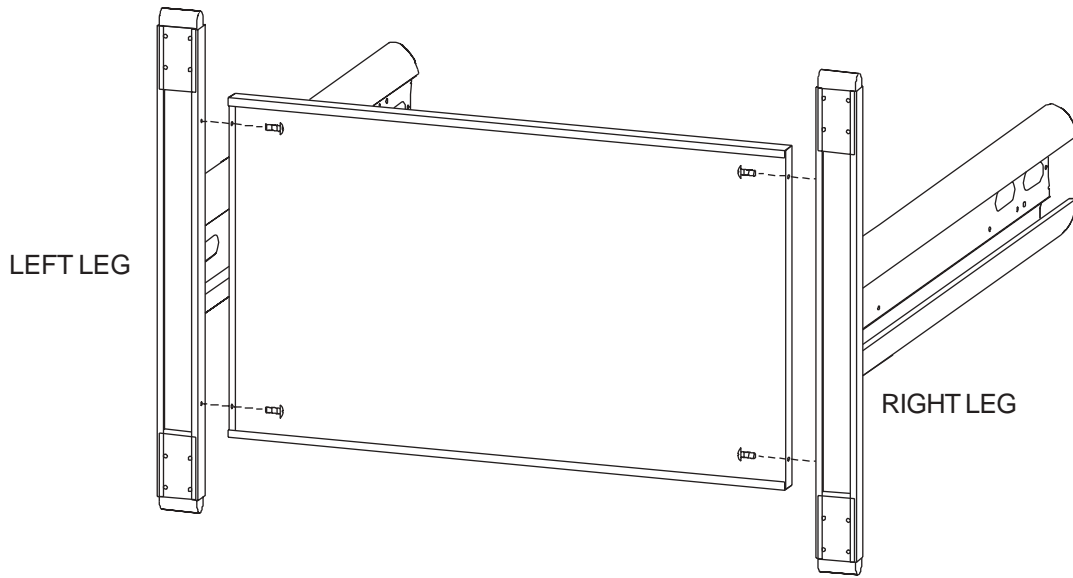

STEP 1

Lay leg assemblies down and attach the bottom shelf between the legs with screws (AA) as shown.

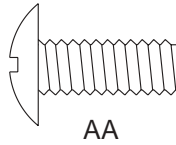

AA

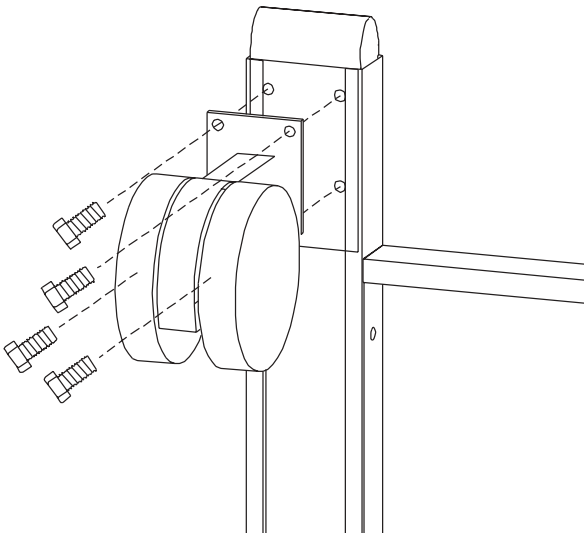

STEP 2

Attach the casters to each leg with screws (BB) as shown. **NOTE:** Both locking casters should be attached to the same leg.

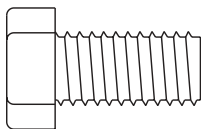

BB

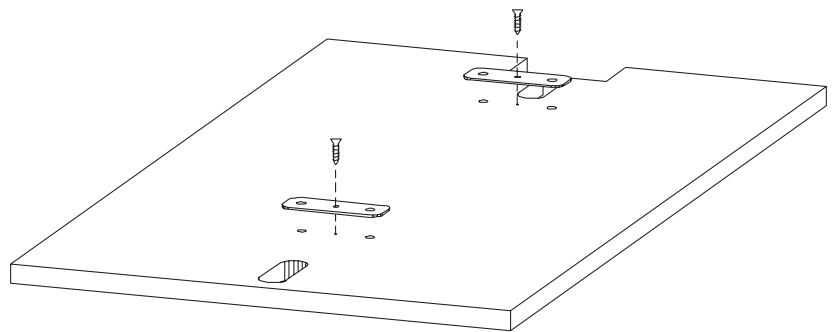

STEP 3

THIS STEP IS FOR VENEER MODELS ONLY! IF YOU HAVE A LAMINATE MODEL SKIP THIS STEP. Attach the shim plates to the outside edges of both side panels with screws (CC) as shown.

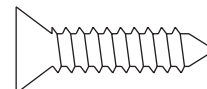

CC

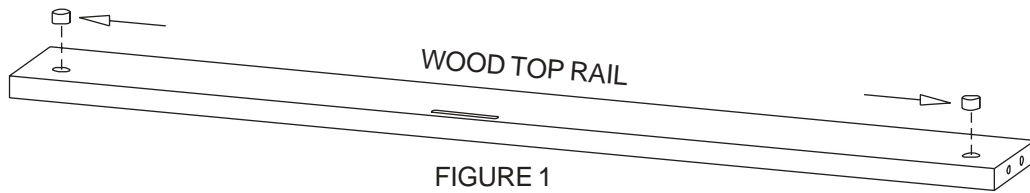

FIGURE 1

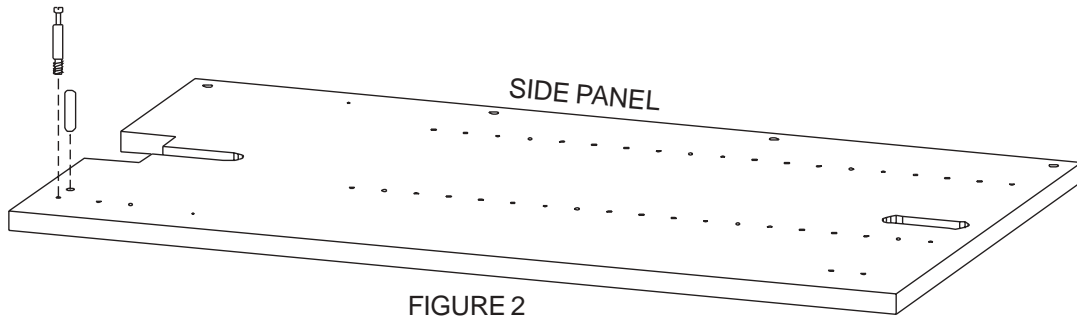
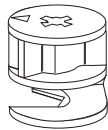

FIGURE 2

STEP 4

Lay the wood top rail down with holes facing up as shown in **FIGURE 1**. Insert a cam lock (DD) into each hole. Make sure the arrow on the cam lock faces the edge of the rail as shown. Lay one side panel down with holes facing up as shown in **FIGURE 2**. Insert a locking screw (EE) into the small hole and insert a wood dowel (FF) into the larger hole in the locations shown in **FIGURE 2**. Attach the remaining locking screw and wood dowel to the other side panel as described above.



DD

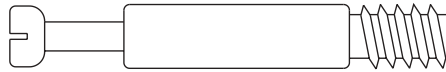

EE

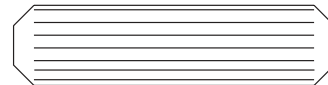

FF

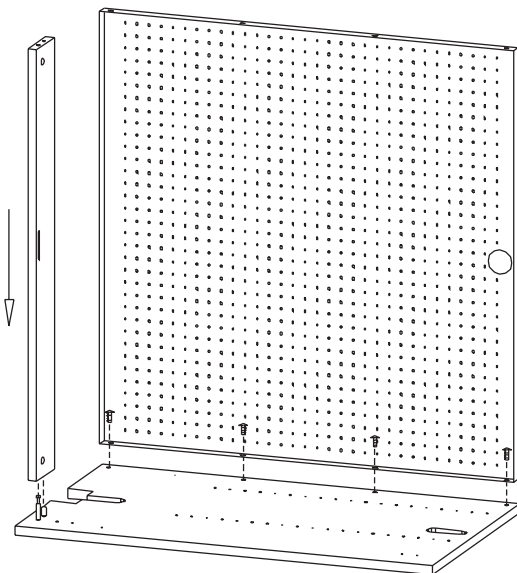

FIGURE 3

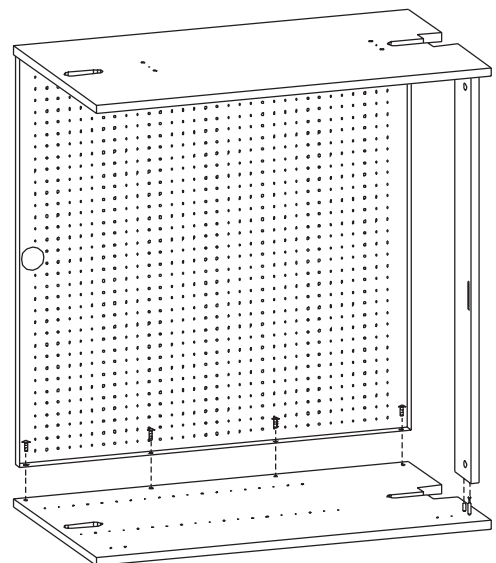
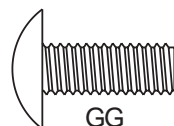

FIGURE 4

STEP 5

Position the top rail onto the locking screw and wood dowel in the side panel with holes facing in as shown in **FIGURE 3**. Attach the back panel onto the side panel with screws (GG) as shown. **CAREFULLY** position this assembly onto the other side panel as shown in **FIGURE 4**. Attach the back panel on with screws (GG). Once the back panel is attached, **TIGHTEN THE CAM LOCK ON THE TOP RAIL.**



GG

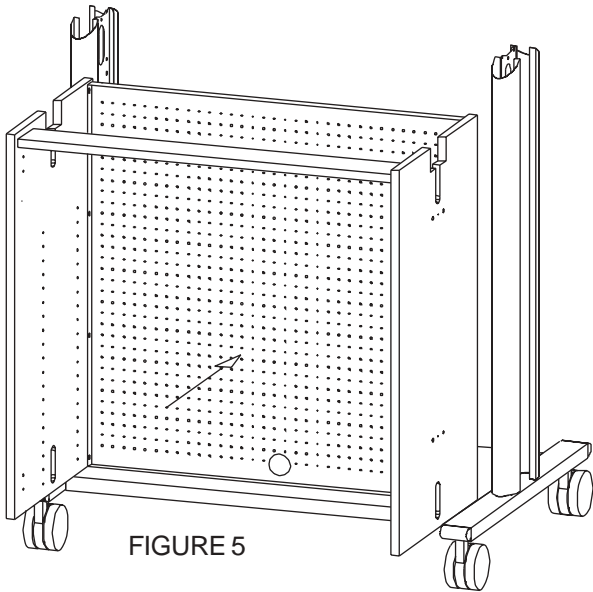

FIGURE 5

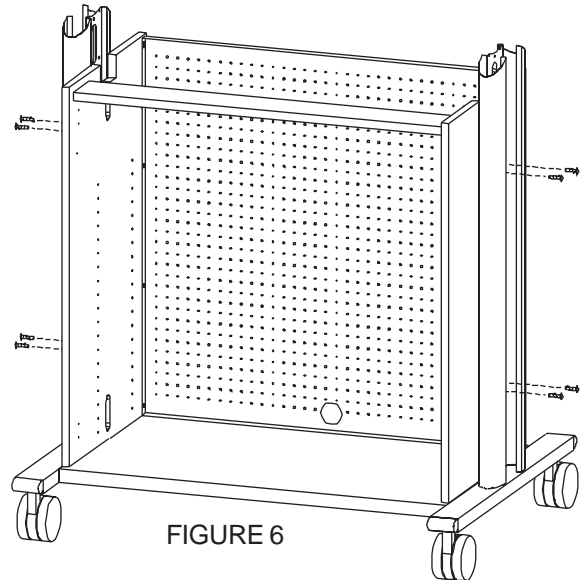
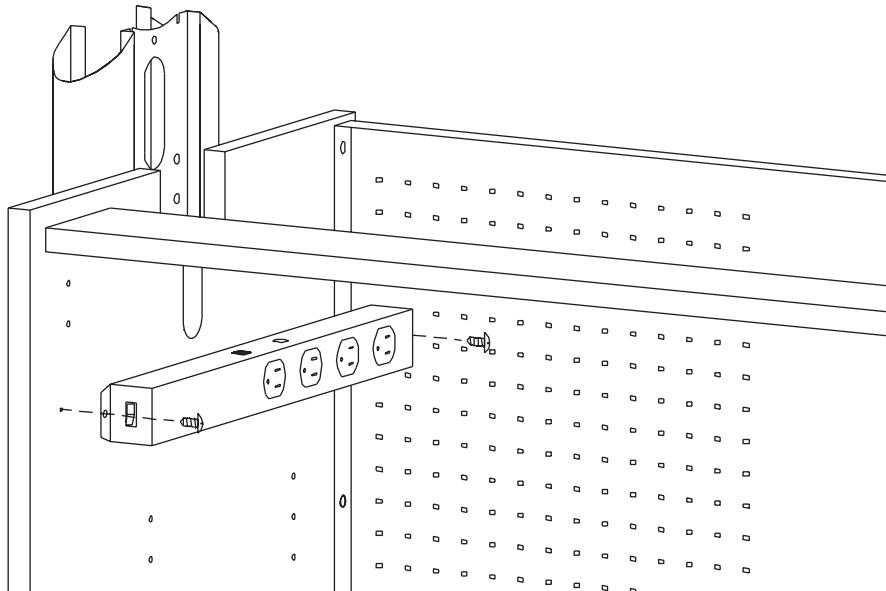
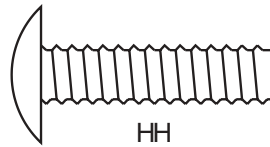

FIGURE 6

STEP 6

Slide the side panel assembly into the cart as shown in **FIGURE 5**. **LOOSELY** secure the sides to the cart with screws ((HH) as shown in **FIGURE 6**.



STEP 7

Attach the electrical unit to the left side panel with the hardware enclosed in its package. **NOTE:** Be sure to position the electrical unit with the switch facing the front of the cart.

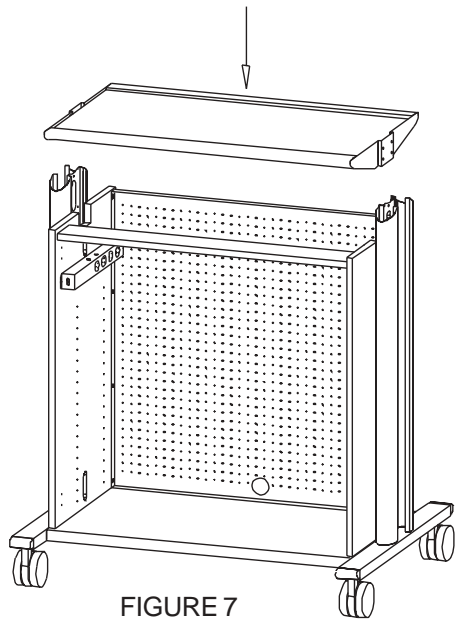

FIGURE 7

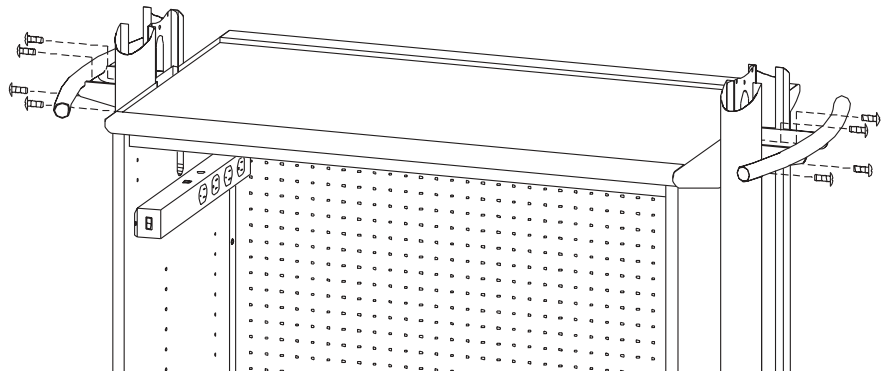
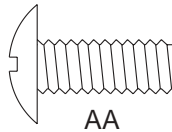

FIGURE 8

STEP 8

Slide the top shelf on between the uprights as shown in **FIGURE 7**. Align each cart handle with one of the 2 sets of holes on both sides of the top shelf. Secure the handle and top shelf to the upright with screws (AA) as shown in **FIGURE 8**. Once the top shelf is secure, **TIGHTEN THE SIDE PANELS IN PLACE.**



AA

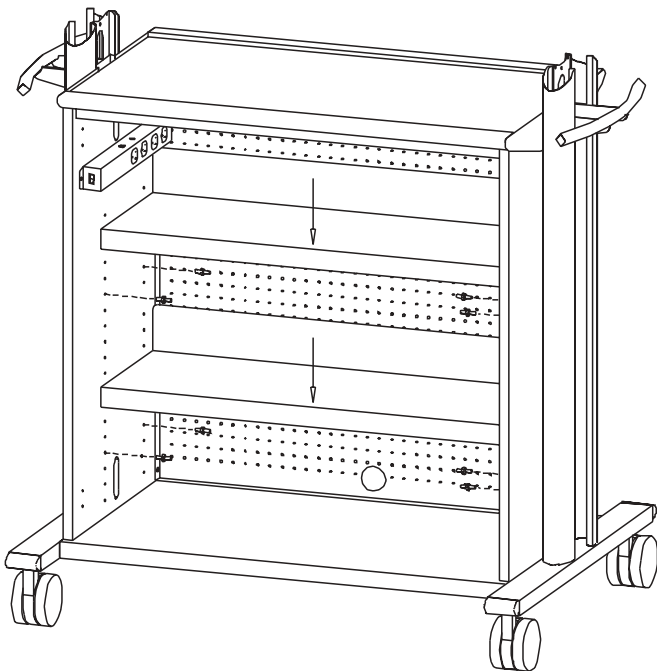

STEP 9

Insert the collar pins (II) into any desired set of holes on both side panels. Place each adjustable shelf onto the collar pins as shown.

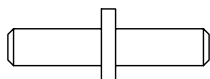

II

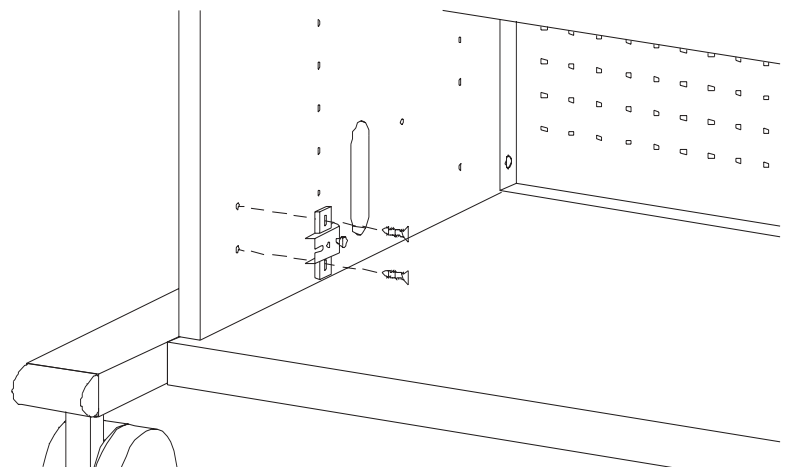

STEP 10

Attach the hinge plates in place with screws (CC) as shown. **NOTE:** Attach the other hinge plates in the 3 other corners of the side panels.

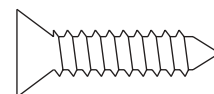

CC

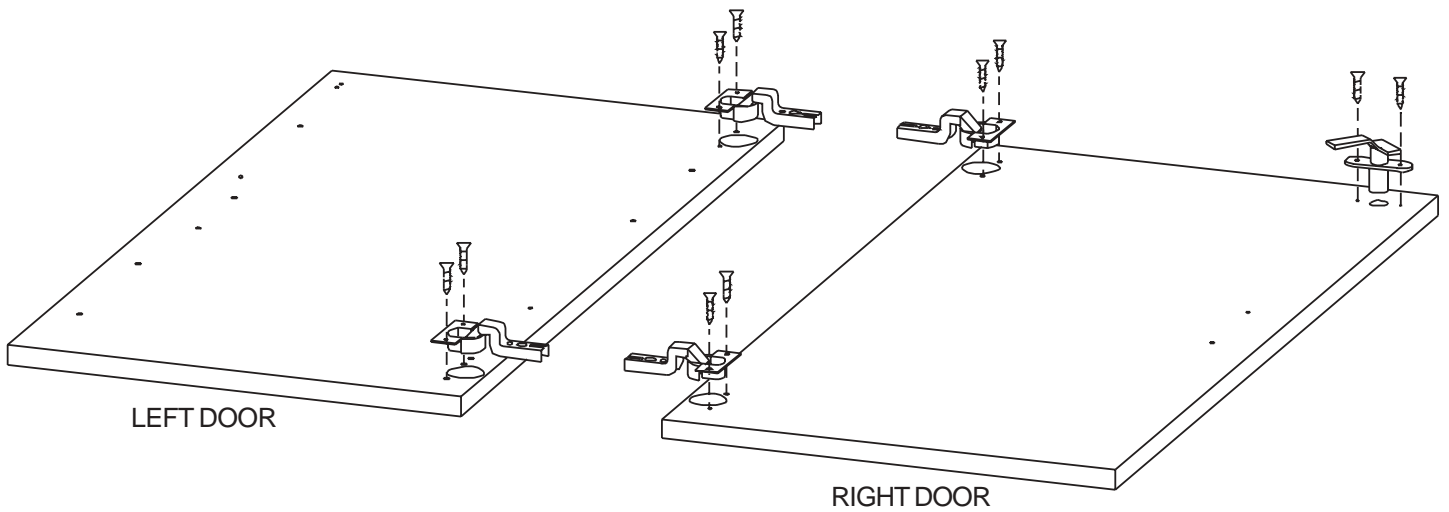

STEP 11

Attach the hinges to each door with screws (CC) as shown. Attach the lock to the top of the right door with screws (CC) as shown. **NOTE:** Make sure the lock is positioned as it is shown.

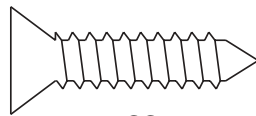

CC

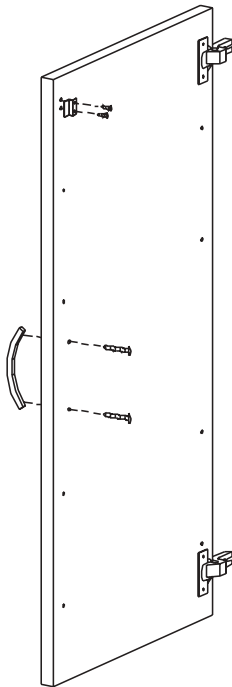

STEP 12

Attach the strike plate to the top of the left door with screws (KK) as shown. Attach a handle to each door with screws (LL) as shown. Attach a felt pad (MM) to the top each door .

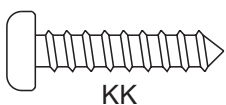

KK



LL

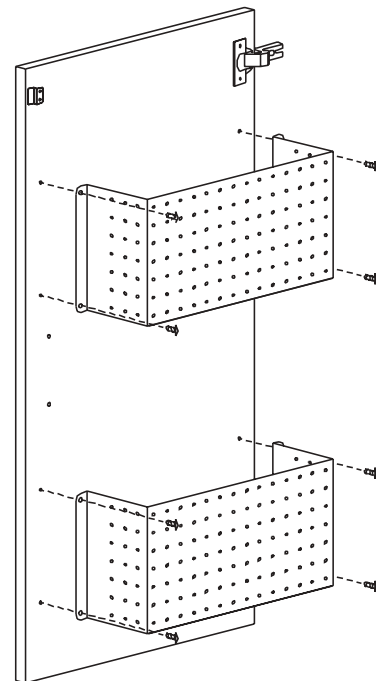

STEP 13

Attach the baskets to the left door with screws (NN) as shown.

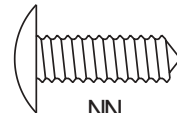

NN

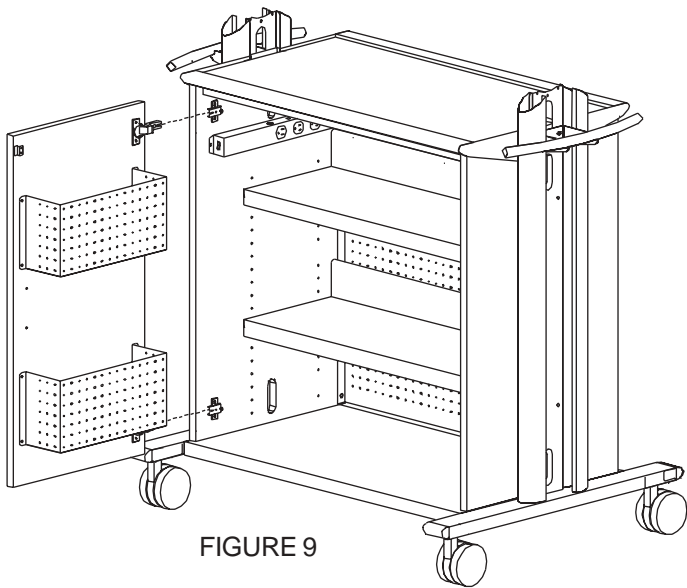

FIGURE 9

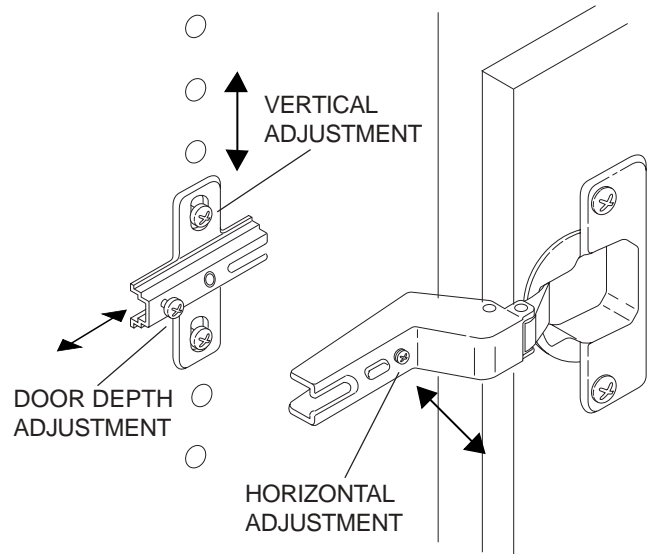

FIGURE 10

STEP 14

Attach each door so that the hinges slide over the hinge plates. **(FIGURE 9)** Make sure the screw in the hinge plate slides into the groove in the hinge. Adjust the hinges as necessary to make sure the doors meet properly. **FIGURE 10** indicates which screws have which effect on the door panels.

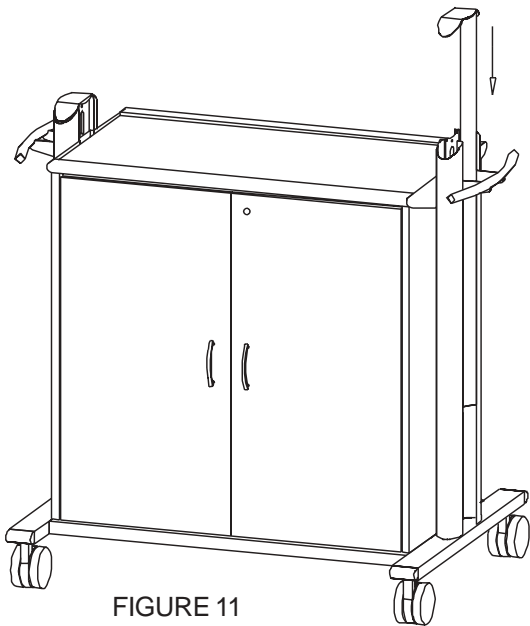

FIGURE 11

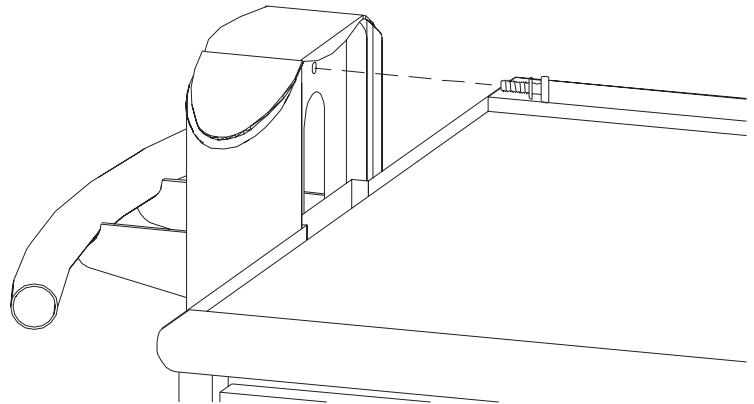
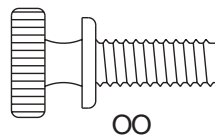
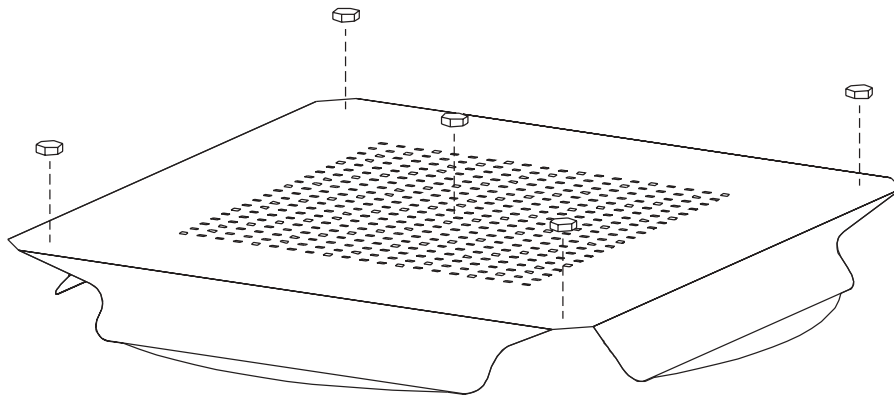

FIGURE 12

STEP 15

Slide the insert panels inside the uprights as shown in **FIGURE 11**. Fasten insert panels in place with screws (OO) as shown in **FIGURE 12**.





STEP 16

Fasten 5 bumpers (PP) to the bottom of each serving tray as shown.

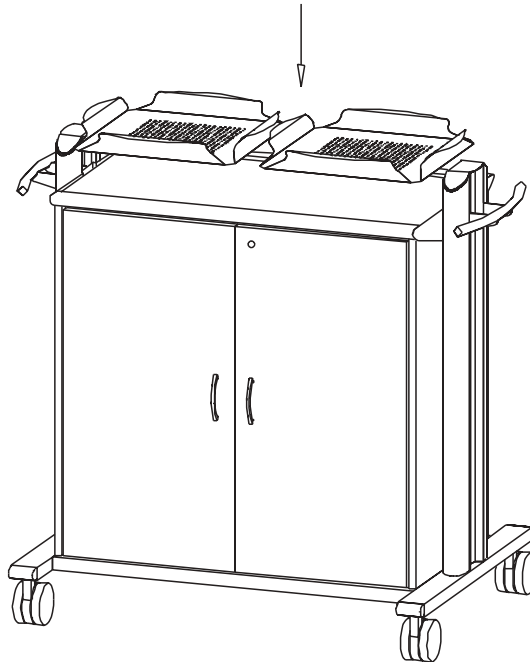

STEP 17

Place rubber mats on the top shelf and the 2 adjustable shelves.
Place the serving trays on top of the top shelf as shown.

Bretford
11000 Seymour Avenue
Franklin Park, IL 60131
TEL: 847.678.2545
800.521.9614
FAX: 847.678.0852
800.343.1779

Bretford Ltd.
Technology House
7 Lake End Court, Taplow
Bucks SL6 0JQ England
TEL: 01628 603558
FAX: 01628 604923

www.bretford.com

Part#031-2855
Rev.06.18.10 CZ