

**ATLANTA™ 19" ROUND  
DROP-IN LAVATORY**

**Product Features:**

- Long lasting, acid resisting, enameled steel construction
- Concealed front overflow
- Convenient soap depressions
- Raised ledge minimizes backsplash
- Includes mounting brackets for easy installation
- Shipping weight: 10 lbs.

**1315V** 4" (102mm) faucet centers

**Nominal Dimensions:**

483mm Round x 165mm  
(19" x 19" x 6½")

**Bowl Sizes:**

400mm (15¾") wide  
283mm (11⅛") front to back  
165mm (6½") deep

**Compliance Certifications –**

**Meets or Exceeds the Following Specifications:**

- ASME A112.19.4M for Enameled Steel Plumbing Fixtures
- IAPMO (UPC)

**To Be Specified:**

- Color:
- Faucet:
- Faucet Finish:
- Supplies:
- 1-1/4" Trap:

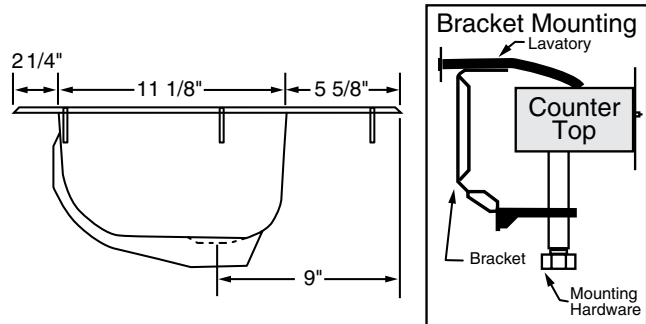
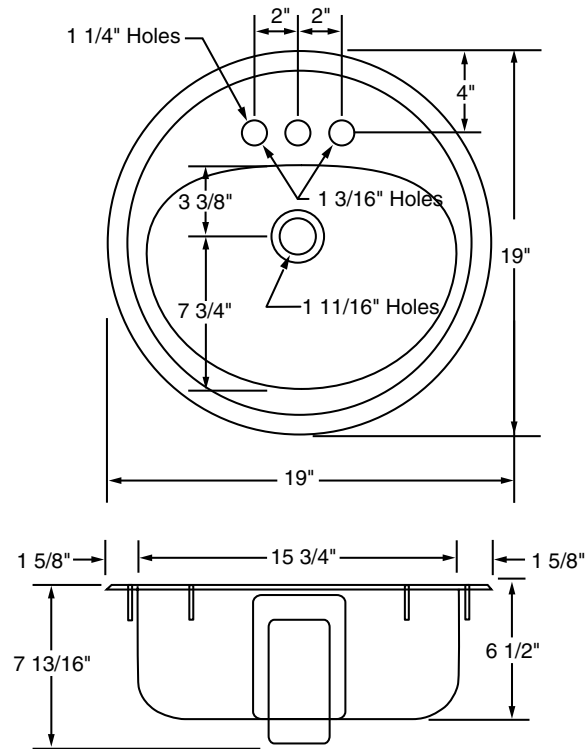

 • When installed so top of sink is 876mm (34½") from finished floor. **MEETS THE AMERICANS WITH DISABILITIES ACT GUIDELINES AND ANSI A117.1 ACCESSIBLE AND USEABLE BUILDINGS AND FACILITIES – CHECK LOCAL CODES.**

**IMPORTANT:** Dimensions of fixtures are nominal and may vary within the range of tolerances established by ANSI Standard A112.19.4.