



Features

- WDI EcoFlush™ Pressure Assist Vessel
- Dual-Flush and Environmentally Friendly Flushing Technology
- Push Lever Down for High Efficiency Flush (1.1 gpf / 4.0 lpf)
- Push Lever Up for Full Flush (1.6 gpf / 6.0 lpf)
- 1.1 gpf / 4.0 lpf Qualifies for One (1) LEED point
- 16-1/4" [413mm] RelaxedHeight™ (ADA) Bowl With Bed Pan Lugs
- Air Activated Dual-Function Valve for an Easy-Touch Flush
- Quieter Flushing Performance
- No Tank Sweating or Flapper Leaking
- 2" [51 mm] Fully Glazed Trapway
- Available in White Only
- Limited Lifetime Warranty



Model 31880

Model #	Description
31880	Two-piece toilet combination, 16-1/4" [413 mm] RelaxedHeight™(ADA), elongated front with bed pan lugs, 12" [305mm] rough-in. Includes EcoFlush™ pressure assist vessel and polished chrome trip lever, less toilet seat and supply.
3H829	16-1/4" [413 mm] RelaxedHeight™ (ADA), elongated front with bed pan lugs, toilet bowl 12" [305 mm] rough-in.
31500	Tank and cover only with left hand trip lever.

High Efficiency Toilet

HET

ECO|FLUSH™

RelaxedHEIGHT™  **ADA**

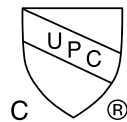

Optional Tanks

31501	Same as 31500 with right hand trip lever
TP	Tamper proof locking lid (add "TP" to any tank model number)



31501 Right hand trip lever

This fixture qualifies according to ASME test procedures as a high efficiency toilet (HET) with an average consumption of 1.1 gpf / 4.0 lpf or less with a minimum water savings of 20%.

Specifications

Water Pressure Range: 20 to 80 P.S.I.

Flush System: Dual Flushing Technology

Water Usage: 1.1 gpf / 4.0 lpf or 1.6 gpf / 6.0 lpf

Water Surface Area: 10-3/4" x 8-1/2"

[273 mm x 216 mm]

Trap Diameter: 2" [51 mm]

Water Seal: 2-1/2" [64 mm]

Shipping Cubes:

3H829 Bowl: 3.3 ft³ [1.10 m³]

31500 Tank: 2.5 ft³ [0.71 m³]

Shipping Weight:

3H829 Bowl: 47 lbs [21 kg]

31500 Tank: 42 lbs [19 kg]

Warranty:

Vitreous China - Limited Lifetime

Vessel - Ten Year Limited

Parts - One Year Limited

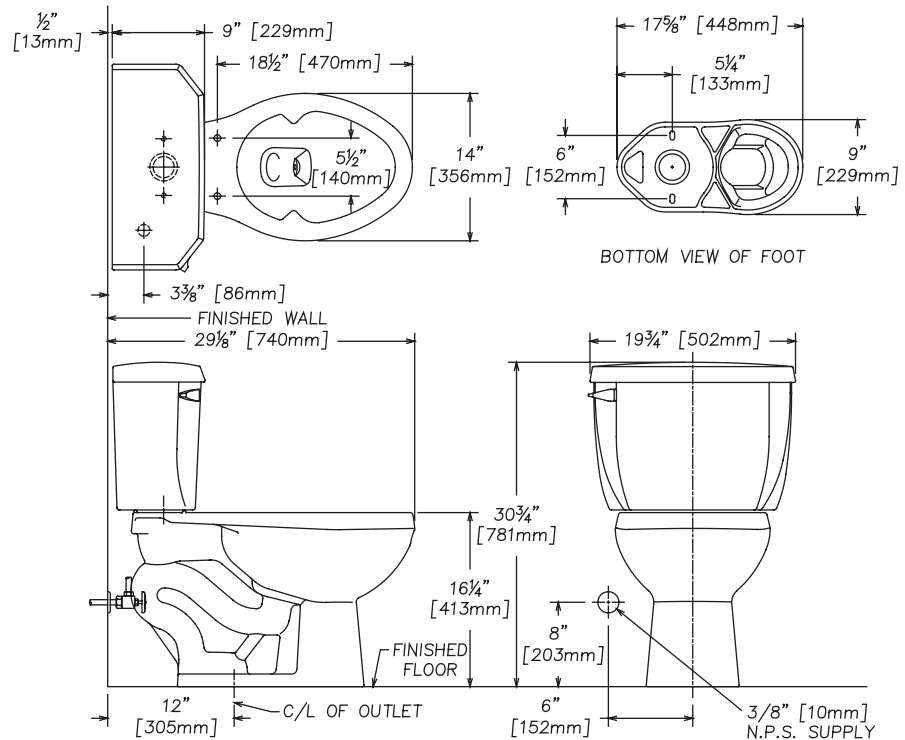

IMPORTANT: These dimensions are nominal and may vary within the range of tolerances established by ASME Standard A 112.19.2

Features and Upgrades



P030219 - Left Hand Trip Lever
P030223 - Right Hand Trip Lever
 Pressure assist vessel with dual-flush operation 1.1 gpf/4.0 lpf or 1.6 gpf/6.0 lpf. Save up to 40% more water than conventional toilets.



P030374 - Left hand trip lever
 Dual-flush operation. Lift up for 1.1 gpf/4.0 lpf or push down for 1.6 gpf/6.0 lpf. Available in Chrome, Polished Brass, Satin Nickel and Oil Rubbed Bronze



P030375 - Right hand trip lever
 Dual-flush operation. Lift up for 1.1 gpf/4.0 lpf or push down for 1.6 gpf/6.0 lpf. Available in Chrome, Polished Brass, Satin Nickel and Oil Rubbed Bronze

Customer Service United States
 41 Cairns Road
 Mansfield, OH 44903
 Email: customerservice@craneplumbing.com

Customer Service Canada
 15 Crane Ave.
 Stratford, ON N5A 6T3
 Email: sales@craneplumbing.ca

www.craneplumbing.com

www.craneplumbing.ca

