

**LAMP® XL-GC03 Sliding Door Lock Installation Manual PAT**  
**XL-GC06 Sliding Door Hanger Installation Manual PAT**  
**XL-GC08 Sliding Door Lock Guide Installation Manual PAT**

Read all instructions carefully before installation. Before starting installation, clear area of any hazardous objects. Be careful to avoid injury.

**Caution** Using this product without observing the cautions may result in the product failure, accidental injury or installation failure.  
 SUGATSUNE guarantees the quality of this product as for all its parts. It cannot however guarantee the assembly of the end product as a whole.

**Caution**

- Applicable glass door size is within W500 mm × H1200 mm and the applicable weight is not more than 12 kg.
- Applicable glass thickness is 8 mm.
- For glass processing, please consult your glazing company.

**Completed Installation**

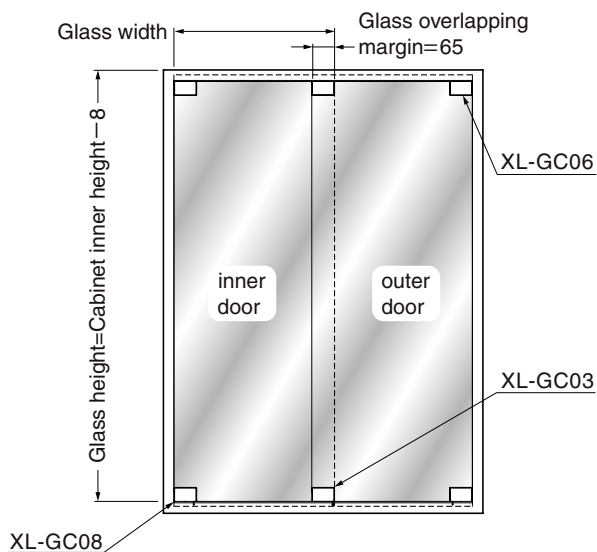

**Precaution of use**

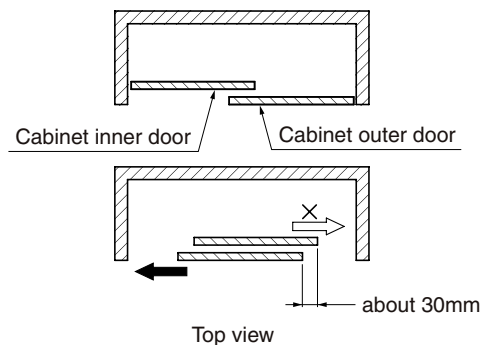

**Caution**

Cabinet inner door cannot slide more than 30mm further right than the outer door. Forcibly trying to open the door further will result in damage to the parts.

**XL-GC06 Sliding Door Hanger Metal Fitting of Parts Structure**

- |   |  |
|---|--|
| ①  ...Glass Fixing (for left side) × 2  | ⑤  ...Boss (shaft) Cover × 8                           |
| ②  ...Glass Fixing (for right side) × 2 | ⑥  ...Gasket × 8 (affixed to parts ①②③④)               |
| ③  ...Back Plate for Outer Door × 2     | ⑦  ...Cap Screw × 8 (M5×1 Hexagon socket flat head)    |
| ④  ...Back Plate for Inner Door × 2     | ⑧  ...Roller Axial Bolts × 4 (Part number:11-0102-005) |

● Other Parts (order separately)

- |   |
|---|
| ⑨  ...Upper Roller × 4 (Part number:53-3061-081)      |
| ⑩  ...Rail (1200mm) × 1 (Part number: XL-GC06-UL1200) |

Prepare nominal 3×16 cross-recessed flat head tapping screws when using rail ⑩. 12 screws will be required per rail length of 935mm (For glass width: 500mm × 2 sheets).

## XL-GC03 Sliding Door Lock of Parts Structure

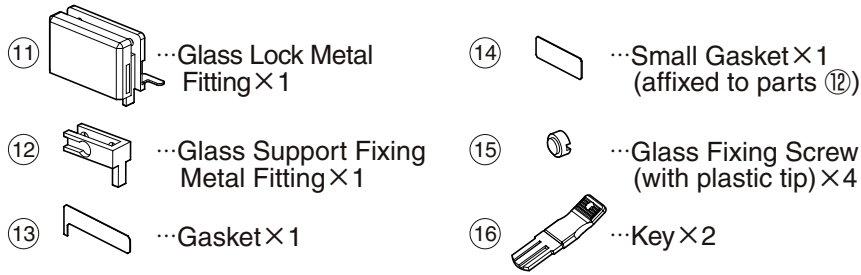

### Other Parts (order separately)



## XL-GC08 Sliding Door Lock Guide of Parts Structure

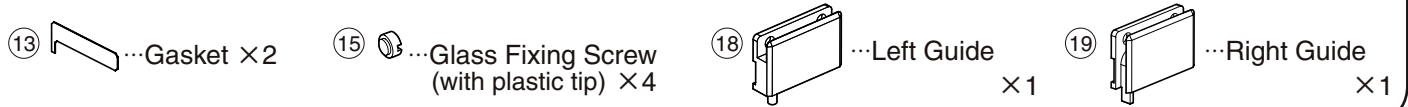

## Glass Door Processing Drawings

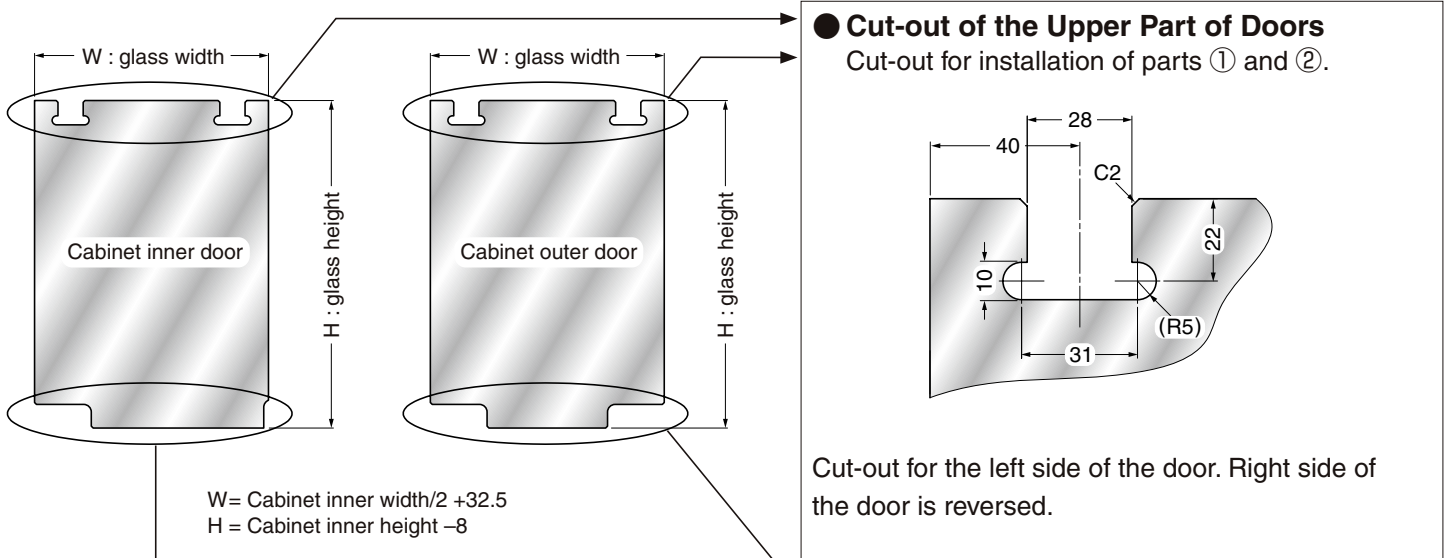

### ● Cut-out for the Lower Part of Inner Door

Cut-out for installation of parts ⑫ and ⑱.

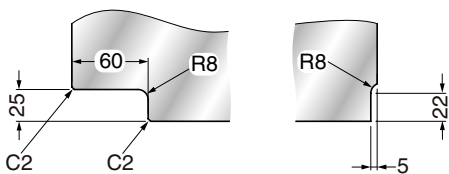

### ● Cut-out for the Lower Part of Outer Door

Cut-out for installation of parts ⑪ and ⑲.

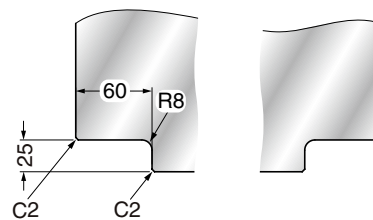

### ⚠ Caution

For glass processing, please consult your glazing company.

## Cabinet and rail workings

### ● Cabinet upper panel workings

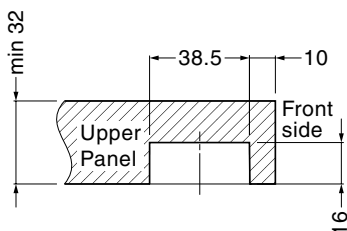

### ● Cabinet lower panel workings

Cut the cabinet lower panel as shown below and insert lower guide rail in it.

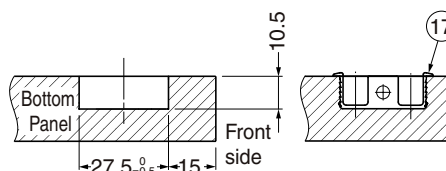

### ● Lower guide rail and upper rail size

Cut upper rail ⑩ and lower guide rail ⑰ to the size of the cabinet inner width.

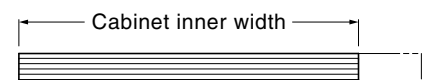

# Glass doors installation steps

## Step 1

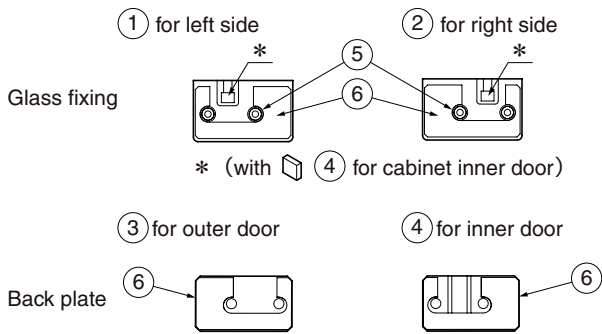

Make sure that the gaskets ⑥ and boss covers ⑤ are on glass fixing ① and ② as shown in top drawing. Glass fixing metal fittings ① and ② are reversed parts for left and right sides. Check that one of each ① and ② and the corresponding back plates ③ are provided.

## Step 2

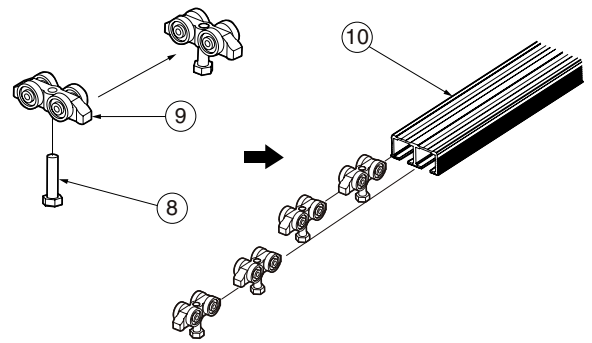

Assemble upper roller ⑨ and roller axial bolts ⑧ and insert them in upper rail ⑩ as shown above.

## Step 3

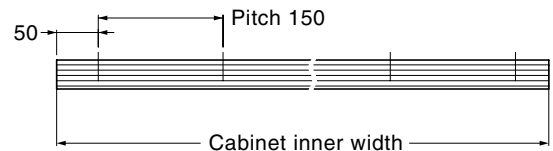
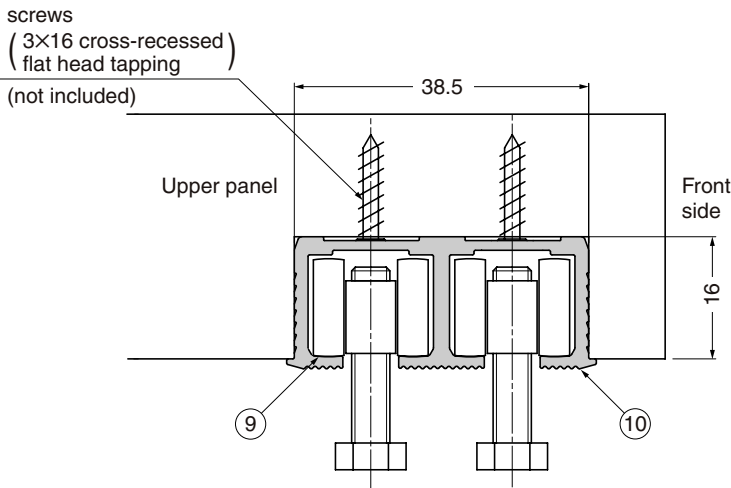

Screws: 3x16 flat head Phillips tapping (not included). Necessary quantity depends on the cabinet inner width. Refer to the drawing below for installation pitch.

### Caution

The top panel must be made of hard timber so that the screws will hold firmly.

## Step 4

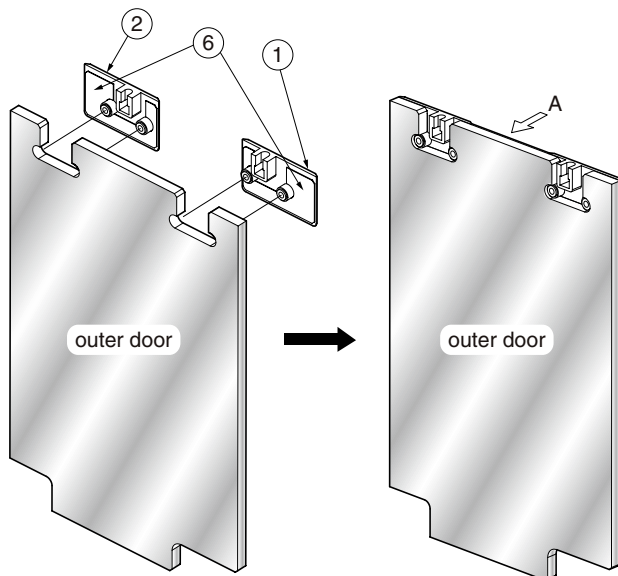

View from inside the cabinet



Remove protective paper backing from gasket ⑥ and fix the gasket to the glass as shown in left drawing.

### Step 5

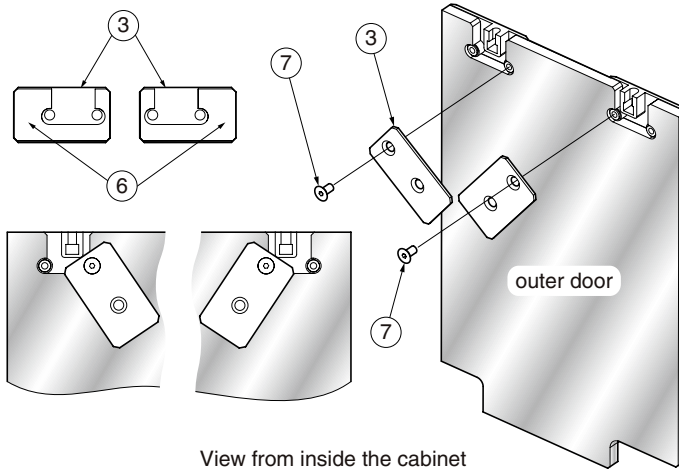

Do not remove protective paper backing from gasket attached to back plate ③. With a hexagon (allen) key, nominal size 4, temporarily fix back plates. Fix only inner screws. Repeat all instructions to this point for inner door of the cabinet.

### ⚠ Caution

Do not remove protective paper backing from gasket on back plates ③ or installation will be difficult.

### Step 6

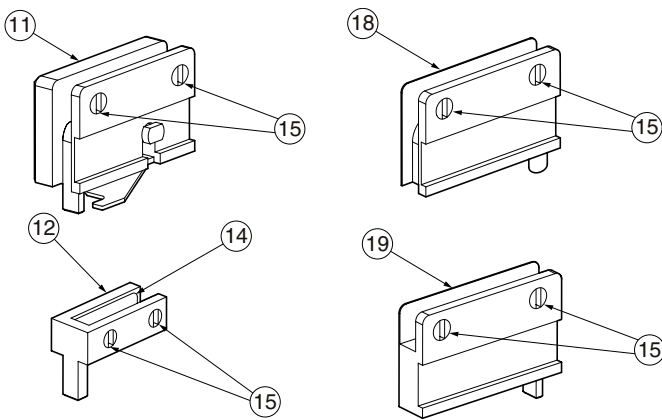

Ensure that parts ⑪⑫⑱ and ⑲ each include 2 screws ⑮. Similarly check that gasket ⑭ is affixed to glass support fixing ⑫.

### Step 7

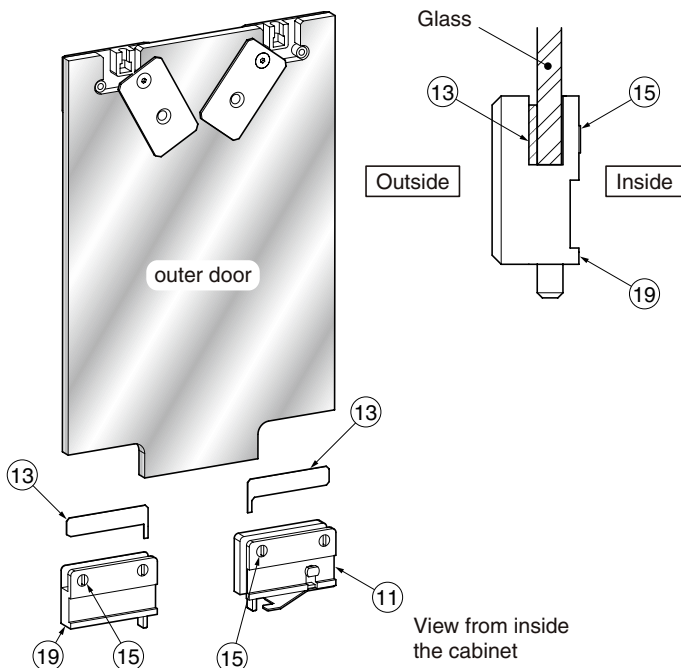

**Glass lock ⑪ and right guide ⑲ installation**  
Both the glass lock ⑪ and right guide ⑲ should be placed so that the screws ⑮ are facing the inside of the cabinet. Ensure that gaskets ⑬ are placed between the outside face of the glass and the hardware as shown above.

### Step 8

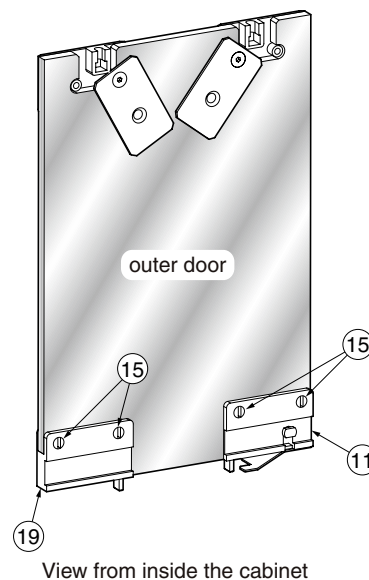

Secure both the glass lock ⑪ and right guide ⑲ by tightening screws ⑮.

### ⚠ Caution

Ensure that the head of screws ⑮ are flush or lower than the surface of the lock ⑪ and guide ⑲.

## Step 9

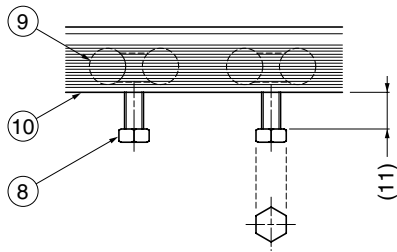

Adjust height of roller bolts ⑧ and orient the head as shown on the drawing on the left.

### **Caution**

Installation is not possible if the bolt head is not oriented properly.

## Step 10

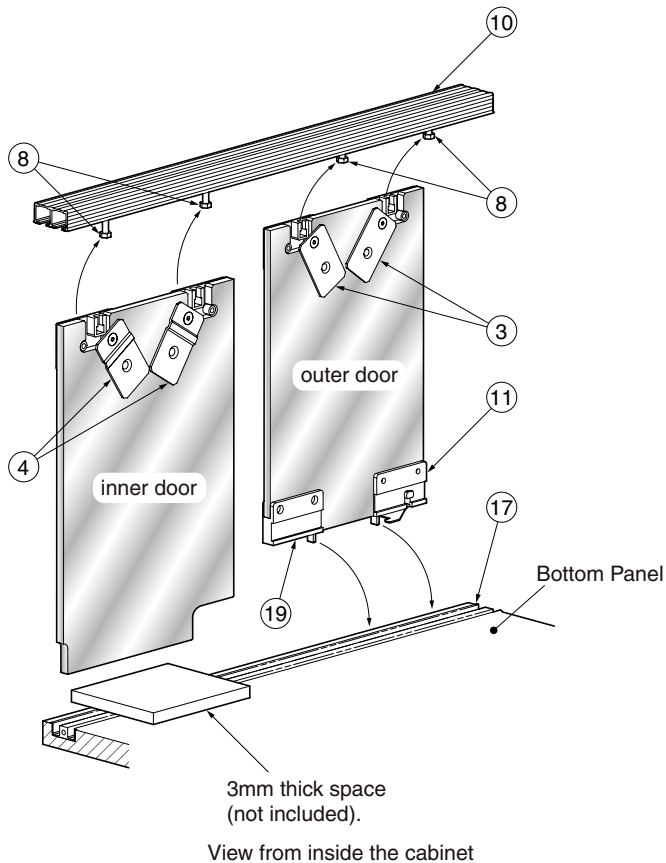

### Inner door installation:

Place a 3mm thick spacer (not included) on top of the lower guide ⑰ to support the inner door. Hang inner door by sliding the head of roller bolts ⑧ inside the glass metal fittings ① and ②. Rotate and fasten back plates ④ with screws ⑦. Remove 3mm spacer from below the door.

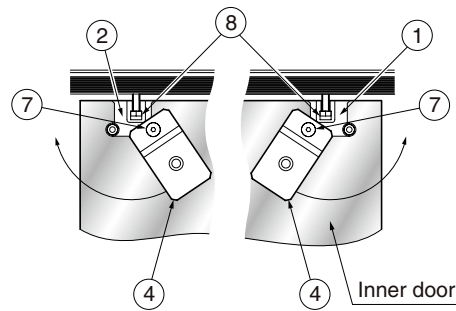

View from inside the cabinet

### Outer door installation:

Insert bottom guide ⑱ and lock ⑪ in the bottom guide rail ⑰. Hang and secure outer door the same way as the inner door.

## Step 11

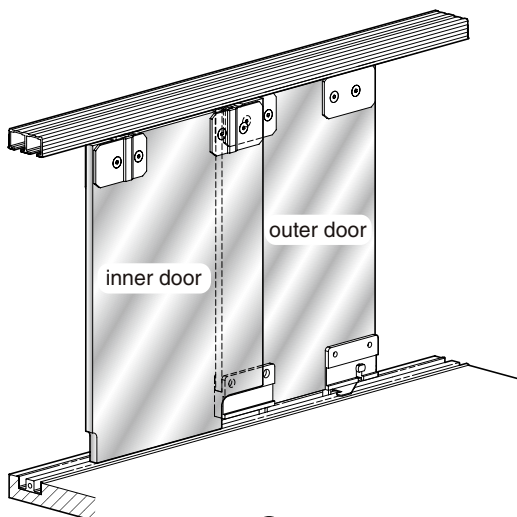

### Support fixing ⑫ installation

View from the inside of the cabinet after step 10.

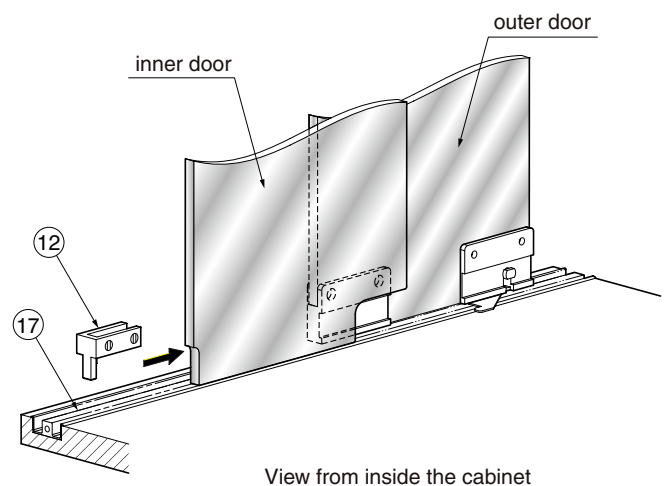

View from inside the cabinet

Insert support fixing ⑫ in the bottom guide rail ⑰. Slide support fixing ⑫ and affix to the inner door.

**⚠ Important** When tightening the screws ⑮ for slide support fixing ⑫, follow the following instructions strictly.

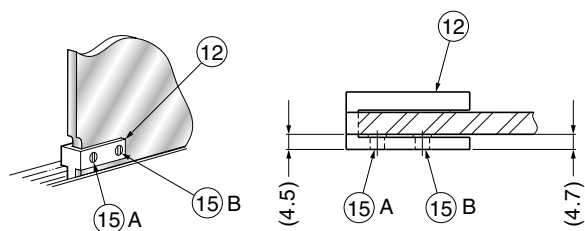

View from inside the cabinet

Top view

First: fasten the outside-most screw marked as A tightly.

Second: secure inside-most screw marked as B until the head is flush with the face of the slide support fixing ⑫.

Sizes in ( ) are for information purpose only.

**⚠ Caution**

Do not over tighten screw ⑮ B as it may bend the slide support fixing ⑫.

● **Positioning:**

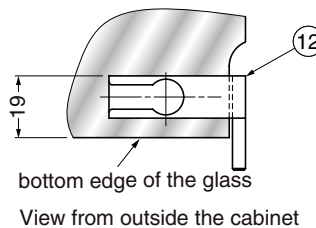

bottom edge of the glass

View from outside the cabinet

Install the slide support fixing ⑫ so that its top edge is 19mm above the bottom edge of the glass door. (After installation, minute height adjustment may be necessary).

**Step 12**

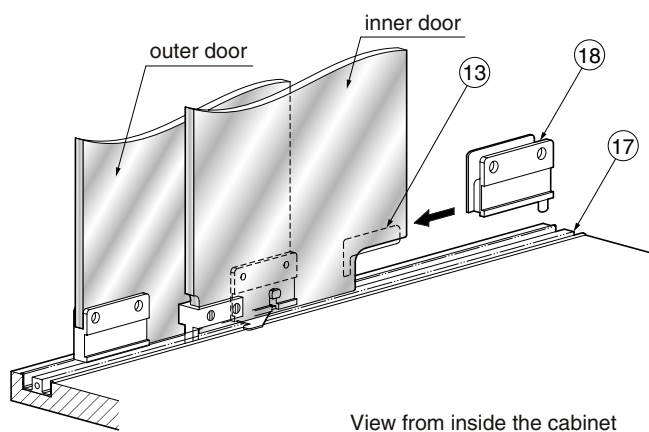

View from inside the cabinet

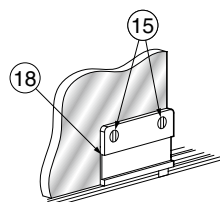
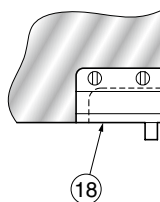

**Left guide ⑱ installation**

View from the inside of the cabinet after step 11.

Slide outer door so that lock fitting ⑪ hooks into the slide support fixing ⑫. Insert left guide ⑱ in the bottom guide rail ⑰.

Slide left guide ⑱ and affix to the inner door. Ensure that gasket ⑬ is between the outside face of the door and the left guide.

Fasten both screws ⑮.

**Step 13**

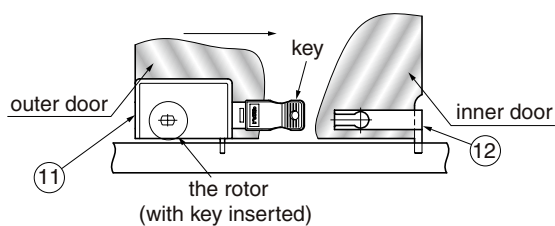

the rotor (with key inserted)

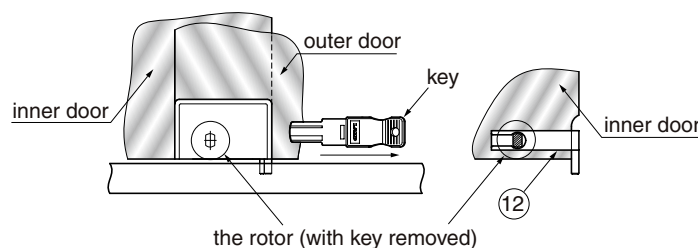

the rotor (with key removed)

Insert the key into the glass lock fitting ⑪ before shutting the door. Check that indicator rotor on back of lock has rotated from a vertical position to a horizontal position.

Shut the door. Remove key. Check that the door has locked. (Rotor should have rotated 90°, locking the door.)

**⚠ Caution**

- Removing the key will lock the door.
- Sliding the doors shut while the key is removed will damage the parts.

For Overseas Customers

**SUGATSUNE KOGYO CO., LTD.**

1-8-11 HigashiKanda, Chiyoda-ku,  
Tokyo 101-8633, Japan  
TEL:+81(0)3-3866-2260 FAX:+81(0)3-3866-4447  
http://www.sugatsune.co.jp  
E-mail : export@sugatsune.co.jp  
ISO9001(JSAQ384) ISO14001(JSAE597) CERTIFICATE.



For North American Customers

**SUGATSUNE AMERICA, INC.**

221 East Selandia Lane,  
Carson, CA 90746, U.S.A.  
TEL:+1-310-329-6373 FAX:+1-310-329-0819  
TOLL FREE:(800) 562-5267 (from U.S.A only)  
http://www.sugatsune.com  
E-mail : sales@sugatsune.com