

## UNIT SHELF TYPE "B"

XL-US02B

SHELVING SYSTEM

UNIT SHELF

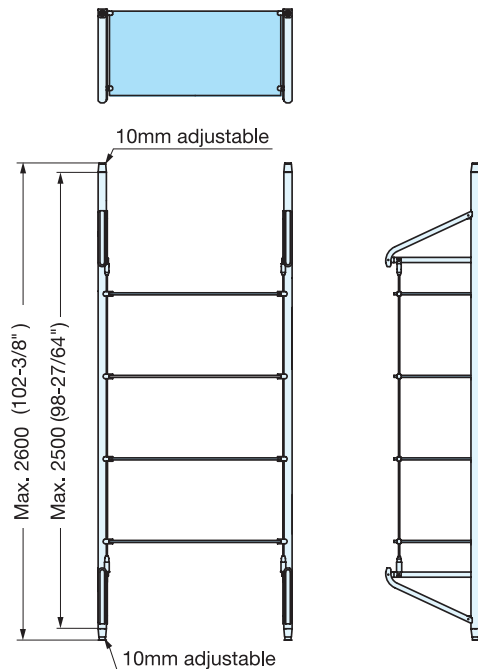

- Adjustable shelf height.
- Designed for top / bottom pressure fit installation with extendable leveling glide.
- Can also be wall mounted by using optional wall mounting bracket.
- Please see page P.497~P.498 for part details.



LED bracket (optional) provides alternative lighting to the shelf space.  
\* XL-US01-W900L

Glass Thickness	8 or 10mm
Overall Height	Max. 2600mm (102-3/8")
Glass Width	Max. 1200mm (47-1/4") (Glass Thickness 8mm)
	Max. 1500mm (59-3/64") (Glass Thickness 10mm)
Glass Depth	400~450mm (15-3/4"~17-23/32")
Load Capacity	Max. 30kg (66lbs) / Shelf

# Application Example



## Back Panel Installation

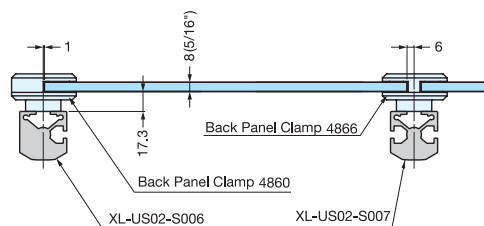

## Back Panel Clamp Installation

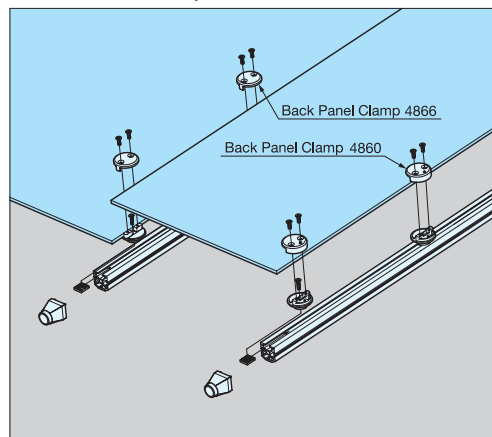

\*Insert clamp fasteners before mounting leveling legs.

## Glass Shelf Dimensions

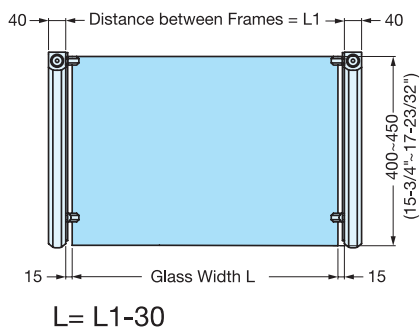

## Vertical Frame Installation

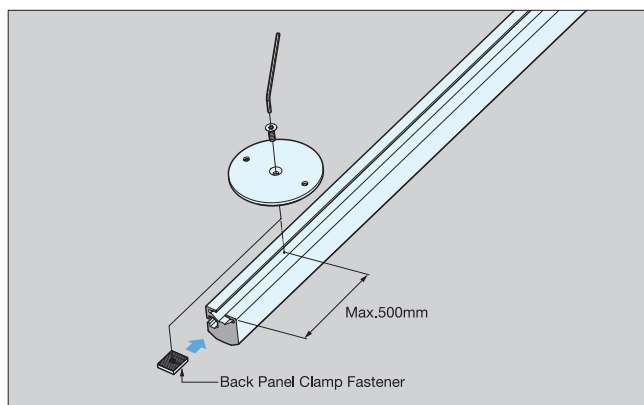

## Safety Pin for glass clamp (Optional)

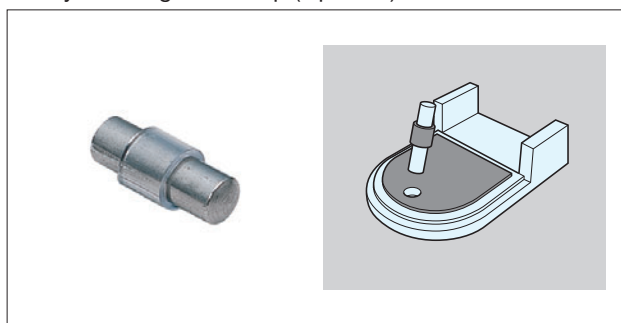

\* Prevents glass slipping out from clamp

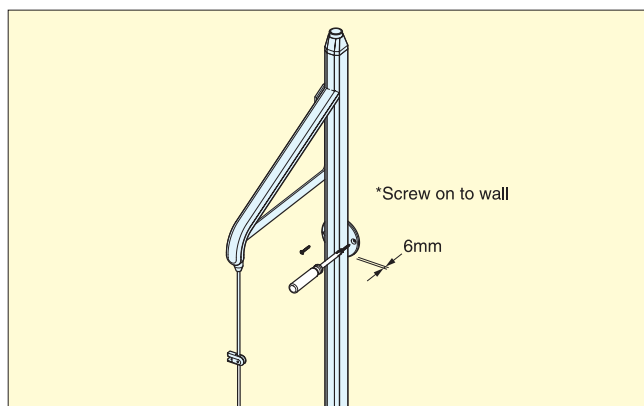

\* Please refer to P.504 for Alternate Vertical Frame Installation

### Detailed View

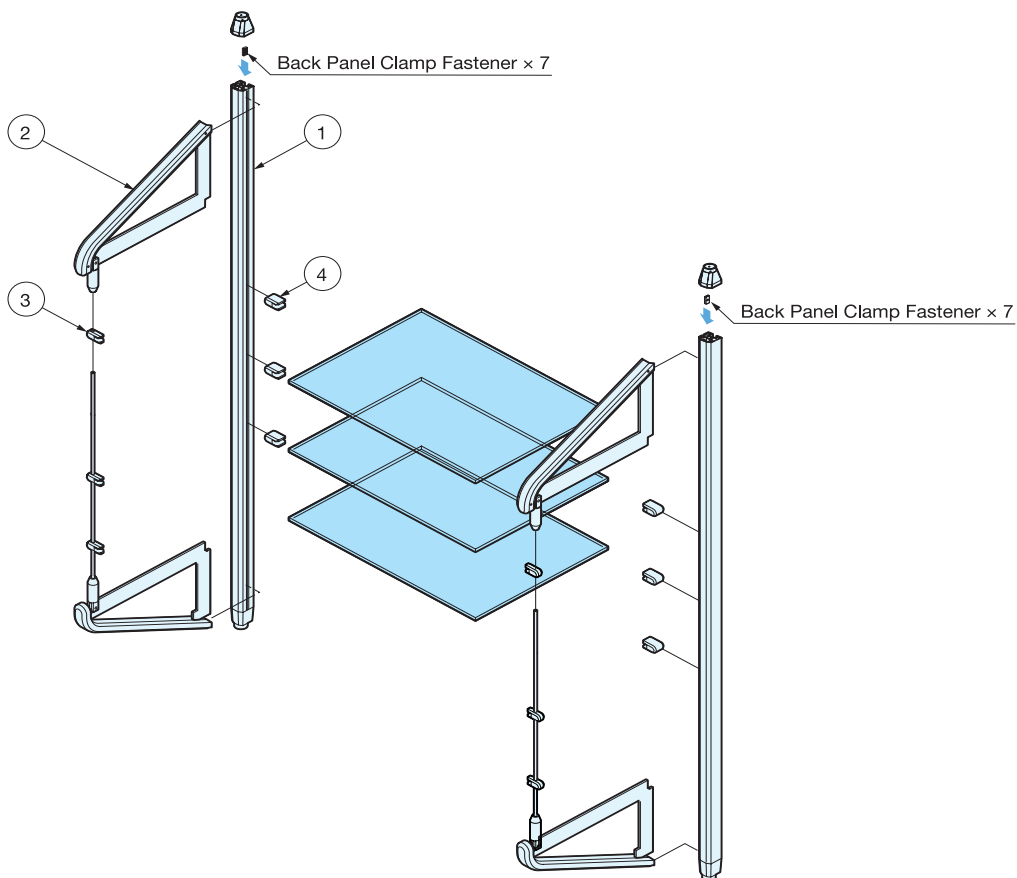

### “Type B” Part Details

No.	Item No.	Part Name	Dimensions	Description
①	XL-US02-S006	Vertical Frame (1 Slot Type)	<p>39.5 30 10mm Height Adjustable Max. 2600 A-A Cross Section 41.5 10mm Height Adjustable</p>	<ul style="list-style-type: none"> <li>● <b>Material</b> Aluminum, Zinc Alloy</li> <li>● <b>Finish / Color</b> Anodized, Grey</li> <li>● <b>Length</b> Max. Height: 2600mm (102-3/8") (Floor to Ceiling)</li> </ul> <p>*2 leveling legs included per frame *Double slotted frame available. Please see XL-US02-S007 on page 501 for details.</p>
②	XL-US02-S011	Type B Wire Kit	<p>Max. 2500 251 455 1500 (59-3/64") 251</p>	<ul style="list-style-type: none"> <li>● <b>Material</b> Aluminum, Steel, 430 Stainless Steel</li> <li>● <b>Finish / Color</b> Matte Chrome</li> </ul> <p>*For Main Frame 2100mm~2500mm</p>

No.	Item No.	Part Name	Dimensions	Description
③	XL-US01-F20	Type B Shelf Support (For Wire Shaft)		<ul style="list-style-type: none"> <li>● <b>Material</b> Zinc Alloy</li> <li>● <b>Finish / Color</b> Matte Chrome</li> <li>*2 Supports necessary for 1 Shelf</li> </ul>
④	XL-US01-B20	Type B Shelf Support (For Main Frame, 2pcs / shelf)		<ul style="list-style-type: none"> <li>● <b>Material</b> Zinc Alloy</li> <li>● <b>Finish / Color</b> Matte Chrome</li> <li>*2 Supports necessary for 1 Shelf</li> </ul>
⑤	XL-US01-W900L-B (Blue)	Shelf Support with LED (For Main Frame, 1pc / shelf)		<ul style="list-style-type: none"> <li>● <b>Material</b> Aluminum</li> <li>● <b>Finish / Color</b> Matte Chrome</li> <li>● <b>Width</b> For glass width 900mm</li> <li>● <b>LED Color</b> Blue, White</li> <li>Power Adapter not included</li> <li>* Recommended Adapter Output: DC24V 1A, Plug: 2.5 x 5.5mm (+), 2 Shelves per Adapter</li> </ul>
	XL-US01-W900L-W (White)			

When using LED

Shelf Support with LED (wiring)

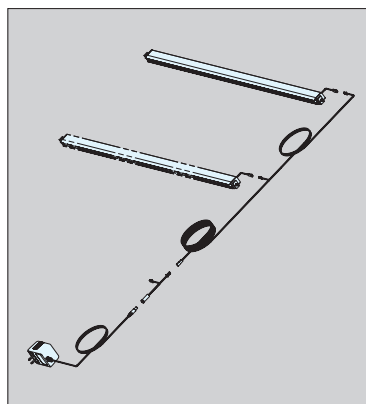

Power Adapter (not included) can be connected to 2 shelf supports with LED

Glass Preparation (when using LED)

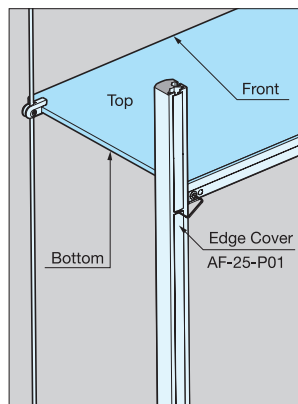

- Sandblasting on top, bottom, front and sides of glass shelf with use of LED will provide the "glow" look. Glass edge attached to LED bracket should be polished.
- Ultra clear glass recommended
- Edge cover AF-25-P01 covers and keeps wires inside frame slot

Type "B" Optional Part Overview Please see page P.505~P.506 for details

Part Name	Wall Mounting Plate	Wall Mounting Bracket	Wall Mounting Bracket	Back Panel Clamp	Back Panel Clamp	Back Panel Clamp Fastener	Edge Cover
Item No.	XL-US02-S010	XL-US02-S008	XL-US02-S009	4860ZN1, 4860ZN5	4866ZN1, 4866ZN5	XL-US02-S013	AF-25-P01-25