

SHIPPED COMPONENTS

- 1 predrilled table top
- 1 column with spider
- 1 base with casters or glides
- 1 au lait hardware kit

TOOLS REQUIRED

- 1 drill-driver with phillips head bit
- 1 hex wrench, 5/16" (Au Lait Hardware Kit)
- 1 torque wrench

AU LAIT SOLID CORE HARDWARE KIT (738027)

- 8 wood screws, 14 x 1" PH, (730017)
- 1 cap screw, 1/2-13 x 2" FHC, (73000204)
- 1 alignment bracket (811924)
- 1 hex wrench, 5/16", (739003)

AU LAIT PHENOLIC HARDWARE KIT (738026)

- 8 machine screws 12-24 x 1/2" FH, (73053807)
- 3 12-24 x 5/8" PH, (730016)
- 1 cap screw, 1/2-13 x 2" FHC, (73000204)
- 1 alignment bracket (811924)
- 1 hex wrench, 5/16", (739003)

Cap screw for base column assembly.

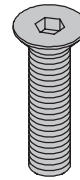

2"

VECTA

A Steelcase Company

fixed base assembly instructions

au lait™

Design: Radar & Vecta Design Team

WARNING: Protect top surface from scratches while attaching base assembly.

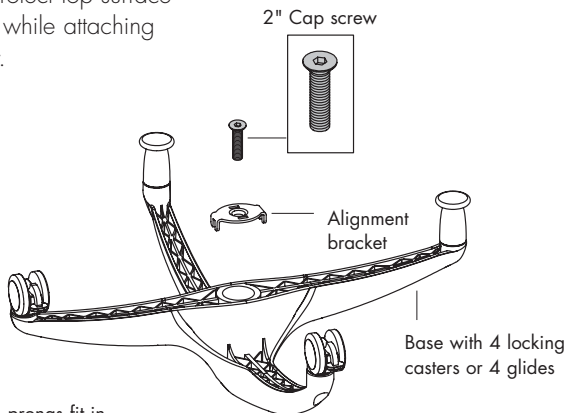

Column prongs fit in alignment bracket slots

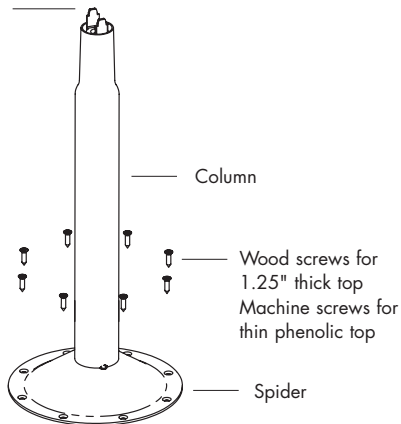

Column

Wood screws for 1.25" thick top
 Machine screws for thin phenolic top

Spider

Fold/store label
 Predrilled holes

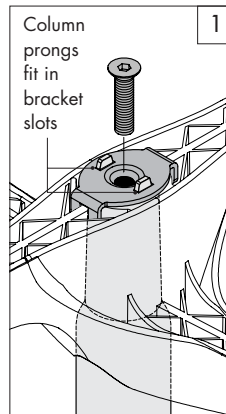

Attach base feet to column/spider assembly.
Tighten the 2" cap screw to 40 foot-pounds.

BASE FEET MUST BE CORRECTLY ALIGNED WITH TOP.

Square/Rectangular Tops: Base feet point toward the corners.

Exception: 39" Square Top: The base feet are perpendicular to the top's edges.

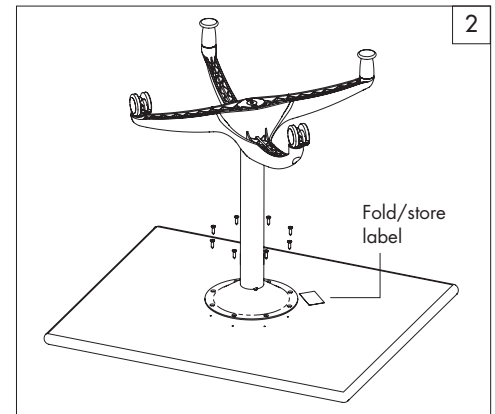
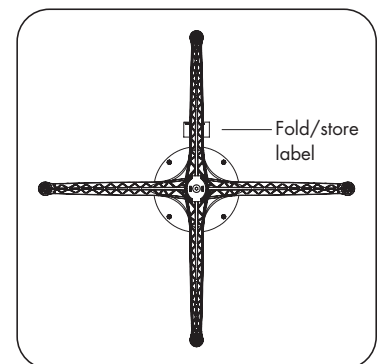
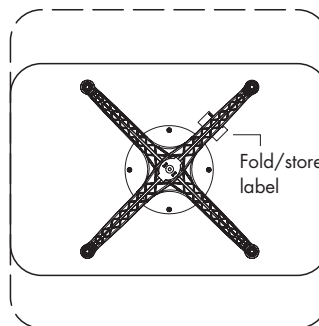

Align base feet with top as shown below.
IMPORTANT: Use wood screws with solid core top. Use machine screws with thin phenolic top.

SHIPPED COMPONENTS

- 1 predrilled table top
- 1 column with spider
- 1 base with casters or glides
- 1 au lait hardware kit

AU LAIT SOLID CORE HARDWARE KIT (738027)

- 8 wood screws, 14 x 1" PH, (730017)
- 1 cap screw, 1/2-13 x 2" FHC, (73000204)
- 1 alignment bracket (811924)
- 1 hex wrench, 5/16", (739003)

AU LAIT PHENOLIC HARDWARE KIT (738026)

- 8 machine screws 12-24 x 1/2" FH, (73053807)
- 3 12-24 x 5/8" PH, (730016)
- 1 cap screw, 1/2-13 x 2" FHC, (73000204)
- 1 alignment bracket (811924)
- 1 hex wrench, 5/16", (739003)

TOOLS REQUIRED

- 1 drill-driver with phillips head bit
- 1 hex wrench, 5/16" (Au Lait Hardware Kit)
- 1 torque wrench

Cap screw for base column assembly

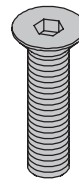

2"

VECTA

A Steelcase Company

flip-top base assembly instructions

au lait™

Design: Radar & Vecta Design Team

WARNING: Protect top surface from scratches while attaching base assembly.

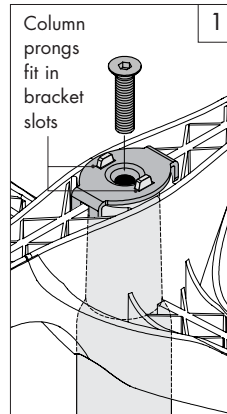
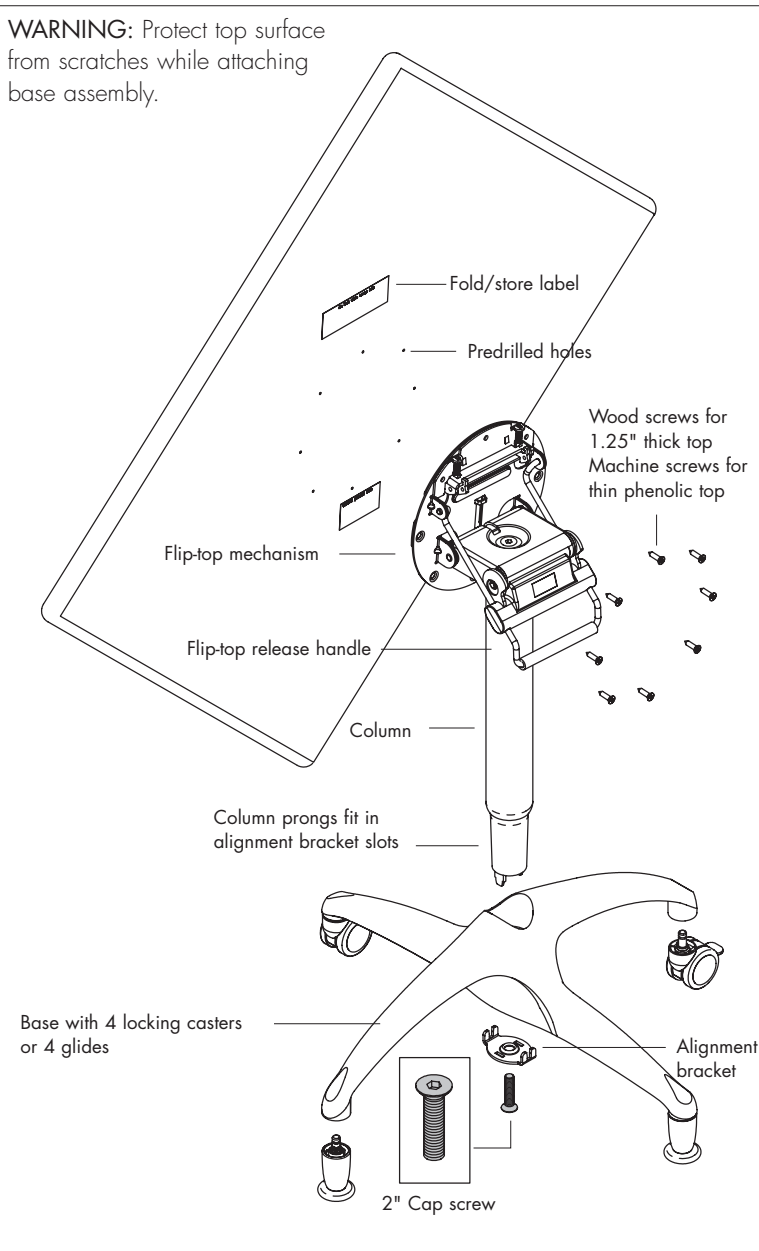

Attach base feet to column/spider assembly.
Tighten the 2" cap screw to 40 foot-pounds.

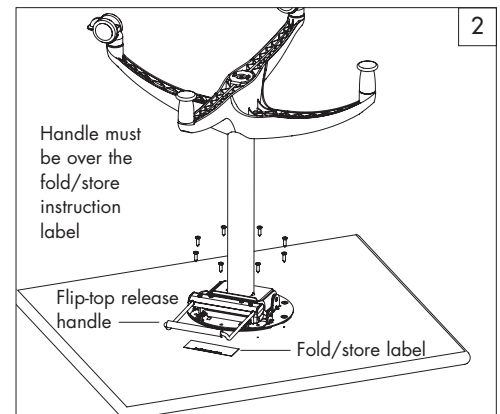

Align base feet with top as shown below.
IMPORTANT: Use wood screws with solid core top. Use machine screws with thin phenolic top.

BASE FEET MUST BE CORRECTLY ALIGNED WITH TOP.

Square/Rectangular Tops: Base feet point toward the corners.

Exception: 39" Square Top: The base feet are perpendicular to the top's edges.

