

au lait flip-top tables have an exclusive nesting base and folding mechanism that provides flexibility to move and store tables for changing meeting and cafeteria functions. This table series is available in two top constructions with three heights, three table shapes, and fixed versions.

Two Top Constructions

1.25"-thick particle board core top is available in laminate or straight grain wood veneer surface with three edge selections. Tops have a backing sheet for balanced construction.

▶ See pages 142-156 for pricing of tables with this top in laminate or wood veneer surfaces with three edge selections.

0.5"-thick solid phenolic tops are available in three colors: 2131 Mellowtone, 2132 White, 2133 Storm Gray.

Tip: Surface color is on both sides of top.

▶ See pages 158-166 for pricing of tables with this top in phenolic.

Solid Core Top Tables

Top is 1.25"-thick particle board core with laminate or straight-grain wood veneer surface.

Laminate tops are available with the following edge profiles: convex vinyl edge, cast urethane edge, or bullnose wood edge.

Wood veneer tops are available with the following edge profiles: convex vinyl edge or bullnose wood edge.

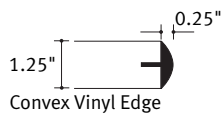

Convex vinyl edge is available in four colors: 6000 Black, 6655 Warm White, 6609 Smoke, or 6607 Woodrose.

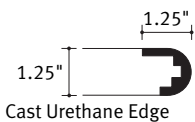

Cast urethane edge is available in four colors: 6000 Black, 6655 Warm White, 6609 Smoke, or 6607 Woodrose.

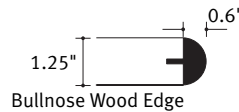

Bullnose wood edge on a wood veneer top is stained to match the wood veneer top. The stain color must be selected when selected as the edge on a laminate top.

Tip: Bullnose wood edges are not recommended on tables with wood-grain laminates because matching of wood-grain laminates and natural, solid wood is not guaranteed. For tables with bullnose wood edge profiles, specify either laminates in solid colors or patterns or wood veneer surfaces.



Convex vinyl edge



Cast urethane edge



Bullnose wood edge

Corner radius on square and rectangular tops is determined by the edge profile selection:

- Convex Vinyl Edge: 2" radius corners
- Cast Urethane Edge: 0.75" radius corners
- Bullnose Wood Edge: softened square radius

Tip: On square and rectangular tops, the bullnose wood edge is butt joined.

Tip: On round tops, the bullnose wood edge is segmented.

Table height is available in three heights:

- Standard height, 28.5"
- Wheelchair height, 33"
- Café height, 42"

▶ See individual product specification pages for availability

Solid Phenolic Top Tables

Solid phenolic top has high strength, and yet it is light weight. It is constructed from multiple layers of recycled paper impregnated with hot phenolic resin and thermally fused together with surface color papers on outer sides and dark core within.

Edge is black. The dark core creates the black edge color.

Corner radius on solid phenolic square and rectangle tops is 0.75".

Table height with solid phenolic top is 0.75" lower than au lait tables with a standard particle board core.

- 27.75" (Standard height, 28.5")
- 32.25" (Wheelchair height, 33")
- 41.25" (Café height, 42")

▶ See individual product specification pages for availability.

All au lait Tables

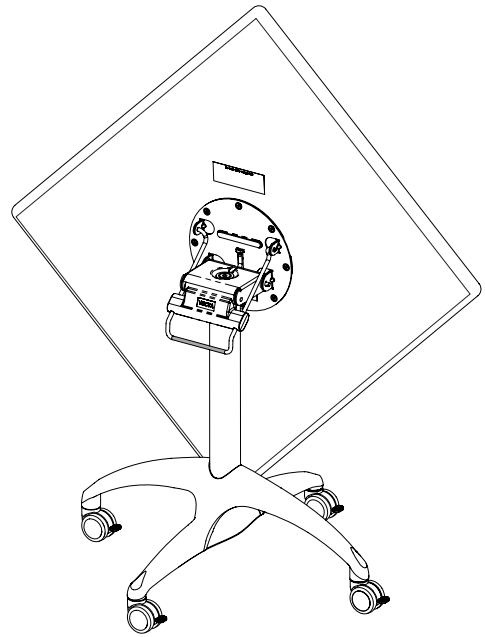

Flip-top mechanism is steel and glass-reinforced nylon with a black finish. The release handle is a chrome-plated formed rod with a clear vinyl bumper. The bumper prevents tables from damaging each other when nested. The flipping mechanism is available on selected tops.

▶ See individual product specification pages for availability.

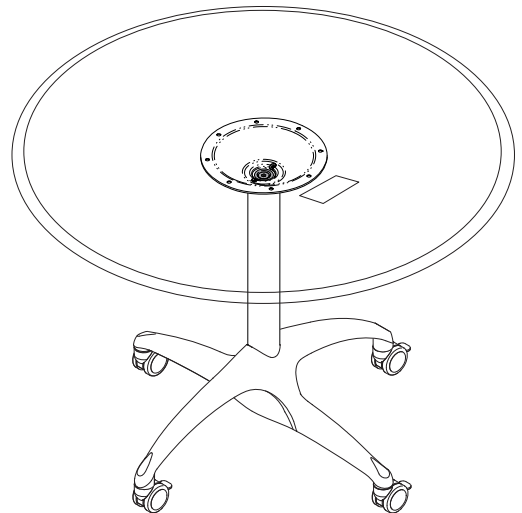

Fixed top spider is formed steel with a black finish. The spider is available on all sizes, shapes, and heights.

Solid Core and Phenolic Tops

DESIGNED BY RADAR AND VECTA DESIGN TEAM
AULAIT

Column is a 2.5"-diameter steel tube with a 0.083" thick wall. The column is always painted the same color as the base.

Base is glass-filled nylon feet available in four textured powder coat colors: Concrete Texture, Highway Texture, Storm Texture, and Tux Texture.

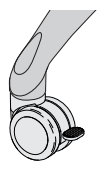

Casters are 2.36" diameter, locking dual wheels that allow the tables to move easily on carpeted or hard floors.

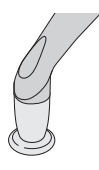

Glides are available as an alternative to casters if high mobility is not required. Glides are black injection molded plastic. Adjustability range is 0.5"H.

Casters and Glides are the same height, are interchangeable and can be used together on the same table. Replacing casters with glides does not alter the table height.

Tip: Casters cannot be adjusted to compensate for uneven floors. Glides should be specified if leveling one top with another is required, but frequent adjustment to glides may be required if tables are moved.

Tip: Au Lait tables placed side by side may not align perfectly. Adjusting the glides can improve alignment, but frequent adjustment may be required. Casters cannot be adjusted to level tables.

Nesting

Au Lait flip-top tables can nest for movement and storage. Bases slide under one another. A vinyl bumper on the flip-top mechanism handle prevents the flipped table top from damaging when nested. Tables can be nested indefinitely. It is recommended that no more than 3 nested tables on casters be moved at one time.

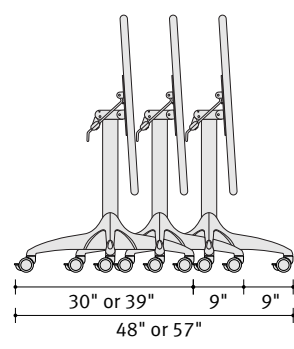

Table with top flipped is 30"W with a 27"W base and 39"W with a 36"W base. Each additional table adds approximately 9". Three nested 27"W base tables occupy about 48" of space. Three 36"W base tables occupy about 57" of space.

Tip: The base dimensions shown include casters oriented as shown, are accurate for storage purposes, but do not match the single base dimensions. See the chart below.

Nesting Dimensions

	Number of nested tables:					
	1	2	3	4	5	6
27" base	30"	39"	48"	57"	66"	75"
36" base	39"	48"	57"	66"	75"	84"

30"- and 36"-Diameter with 27"W Base

- ▶ Master Class, pages 42, 139
- ▶ Product weights, page 482

Standard Includes

- Height: 28.5"H
- Top: 1.25" particle board core with laminate or straight-grain wood veneer surface
- Edge: convex vinyl, bullnose solid wood edge or self-skinning cast urethane.
- Nesting base: 2.5"-diameter steel column and nesting, glass-filled nylon feet with single textured powder coat color
- Fixed top with black steel spider or flip top to allow tables to nest for compact storage
- Patented black flip top mechanism with easy, self-locking chrome release handle
- 2.36"-diameter, locking, dual-wheel casters: black plastic
- Shipped K.D.

Required to Specify

- Product number
- Powder coat color selection for base:
 - 7261 Concrete Texture
 - 7260 Highway Texture
 - 7269 Storm Texture
 - 7268 Tux Texture
- Laminate or wood color number and name for top
- Edge selection:
 - Convex vinyl edge: colors at right
 - Cast urethane edge: colors at right
 - Bullnose solid wood edge

- Vinyl color number and name for convex vinyl edge, if selected: 6000 Black, 6655 Warm White, 6609 Smoke, or 6607 Woodrose
- Vinyl color number and name for cast urethane edge, if selected: 6000 Black, 6655 Warm White, 6609 Smoke, or 6607 Woodrose
- Wood color number and name for wood edge, if selected
Exception: Wood edge will match the surface of a wood veneer top, so no color specification is needed.
Tip: If you specify a wood edge on a top with wood grain laminate, the edge and top may not match.
- Options: if selected (see list)
 ▶ *Surface Materials*, page 52

Options

- **Stain-to-match** ▶ page 47
- **Glides**
 Glides with 0.5" adjustability range factory-installed in place of casters: black. Glides are the same height as casters.
 No cost
 Specify by deleting suffix **C** from the product number.

Accessories

- **Casters** ▶ page 157
- **Glides** ▶ page 157

30"-Diameter



Fixed

AL3000SC
 U.S. Canada



Flip Top

AL3000FSC
 U.S. Canada

36"-Diameter



Fixed

AL3600SC
 U.S. Canada



Flip Top

AL3600FSC
 U.S. Canada

Veneer direction

Solid Core Top
 ▶ 28"H

Convex Vinyl Edge

	AL3000SC	AL3000FSC	AL3600SC	AL3600FSC
Grade 1 Laminate	\$ 527 \$ 553	\$ 644 \$ 676	\$ 564 \$ 592	\$ 679 \$ 713
Grade 2 Laminate	\$ 552 \$ 580	\$ 668 \$ 701	\$ 599 \$ 629	\$ 714 \$ 750
Wood Veneer	\$ 954 \$1002	\$1070 \$1124	\$ 969 \$1017	\$1085 \$1139

Bullnose Wood Edge

	AL3000SC	AL3000FSC	AL3600SC	AL3600FSC
Grade 1 Laminate	\$1076 \$1130	\$1192 \$1252	\$1302 \$1367	\$1419 \$1490
Grade 2 Laminate	\$1101 \$1156	\$1217 \$1278	\$1337 \$1404	\$1453 \$1526
Wood Veneer	\$1503 \$1578	\$1618 \$1699	\$1708 \$1793	\$1823 \$1914

AL3000USC
 U.S. Canada

AL3000UFSC
 U.S. Canada

AL3600USC
 U.S. Canada

AL3600UFSC
 U.S. Canada

Cast Urethane Edge

	AL3000USC	AL3000UFSC	AL3600USC	AL3600UFSC
Grade 1 Laminate	\$ 803 \$ 843	\$ 919 \$ 965	\$ 870 \$ 914	\$ 987 \$1036
Grade 2 Laminate	\$ 828 \$ 869	\$ 943 \$ 990	\$ 906 \$ 951	\$1020 \$1071

24 and 30 Square with 27"W Base

- ▶ Master Class, pages 42, 139
- ▶ Product weights, page 482

Standard Includes

- Height: 28.5"H
- Top: 1.25" particle board core with laminate or straight-grain wood veneer surface
- Edge: convex vinyl, bullnose solid wood edge or self-skinning cast urethane.
- Nesting base: 2.5"-diameter steel column and nesting, glass-filled nylon feet with single textured powder coat color
- Fixed top with black steel spider or flip top to allow tables to nest for compact storage
- Patented black flip top mechanism with easy, self-locking chrome release handle
- 2.36"-diameter, locking, dual-wheel casters: black plastic
- Shipped K.D.

Required to Specify

- Product number
- Powder coat color selection for base:
 - 7261 Concrete Texture
 - 7260 Highway Texture
 - 7269 Storm Texture
 - 7268 Tux Texture
- Laminate or wood color number and name for top
- Edge selection:
 - Convex vinyl edge: colors at right
 - Cast urethane edge: colors at right
 - Bullnose solid wood edge

- Vinyl color number and name for convex vinyl edge, if selected: 6000 Black, 6655 Warm White, 6609 Smoke, or 6607 Woodrose
- Vinyl color number and name for cast urethane edge, if selected: 6000 Black, 6655 Warm White, 6609 Smoke, or 6607 Woodrose
- Wood color number and name for wood edge, if selected
Exception: Wood edge will match the surface of a wood veneer top, so no color specification is needed.
Tip: If you specify a wood edge on a top with wood grain laminate, the edge and top may not match.
- Options: if selected (see list)
▶ *Surface Materials*, page 52

Options

- **Stain-to-match** ▶ page 47
- **Glides**
Glides with 0.5" adjustability range factory-installed in place of casters: black. Glides are the same height as casters.
No cost
Specify by deleting suffix **C** from the product number.

Accessories

- **Casters** ▶ page 157
- **Glides** ▶ page 157

24" x 24"



Fixed

AL2424SC
U.S. Canada



Flip Top

AL2424FSC
U.S. Canada

30" x 30"



Fixed

AL3030SC
U.S. Canada



Flip Top

AL3030FSC
U.S. Canada

Veneer direction

Solid Core Top
▶ 28"H

Convex Vinyl Edge

Grade 1 Laminate	\$ 510	\$ 536	\$ 625	\$ 656	\$ 524	\$ 550	\$ 641	\$ 673
Grade 2 Laminate	\$ 524	\$ 550	\$ 641	\$ 673	\$ 548	\$ 575	\$ 665	\$ 698
Wood Veneer	\$ 972	\$1021	\$1088	\$1142	\$ 988	\$1037	\$1103	\$1158

Bullnose Wood Edge

Grade 1 Laminate	\$ 877	\$ 921	\$ 992	\$1042	\$ 891	\$ 936	\$1008	\$1058
Grade 2 Laminate	\$ 891	\$ 936	\$1008	\$1058	\$ 915	\$ 961	\$1032	\$1084
Wood Veneer	\$1340	\$1407	\$1455	\$1528	\$1355	\$1423	\$1471	\$1545

AL2424USC
U.S. Canada

AL2424UFSC
U.S. Canada

AL3030USC
U.S. Canada

AL3030UFSC
U.S. Canada

Cast Urethane Edge

Grade 1 Laminate	\$ 705	\$ 740	\$ 821	\$ 862	\$ 818	\$ 859	\$ 934	\$ 981
Grade 2 Laminate	\$ 721	\$ 757	\$ 837	\$ 879	\$ 842	\$ 884	\$ 958	\$1006

36", 39", 42", 48" Square with 36"W Base

- ▶ Master Class, pages 42, 139
- ▶ Product weights, page 482

Standard Includes

- Height: 28.5"H
- Top: 1.25" particle board core with laminate or straight-grain wood veneer surface
- Edge: convex vinyl, bullnose solid wood edge or self-skinning cast urethane.
- Nesting base: 2.5"-diameter steel column and nesting, glass-filled nylon feet with single textured powder coat color
- Fixed top with black steel spider or flip top to allow tables to nest for compact storage
- Patented black flip top mechanism with easy, self-locking chrome release handle
- 2.36"-diameter, locking, dual-wheel casters: black plastic
- Shipped K.D.

Required to Specify

- Product number
- Powder coat color selection for base:
 - 7261 Concrete Texture
 - 7260 Highway Texture
 - 7269 Storm Texture
 - 7268 Tux Texture
- Laminate or wood color number and name for top
- Edge selection:
 - Convex vinyl edge: colors at right
 - Cast urethane edge: colors at right
 - Bullnose solid wood edge





- Vinyl color number and name for convex vinyl edge, if selected: 6000 Black, 6655 Warm White, 6609 Smoke, or 6607 Woodrose
- Vinyl color number and name for cast urethane edge, if selected: 6000 Black, 6655 Warm White, 6609 Smoke, or 6607 Woodrose
- Wood color number and name for wood edge, if selected
Exception: Wood edge will match the surface of a wood veneer top, so no color specification is needed.
Tip: If you specify a wood edge on a top with wood grain laminate, the edge and top may not match.
- Options: if selected (see list)
 - ▶ **Surface Materials**, page 52

Options

- **Stain-to-match** ▶ page 47
- **Glides**
Glides with 0.5" adjustability range factory-installed in place of casters: black. Glides are the same height as casters.
No cost
Specify by deleting suffix **C** from the product number.

Accessories

- **Casters** ▶ page 157
- **Glides** ▶ page 157

	36" x 36"	39" x 39"	42" x 42"	48" x 48"
Veneer direction 	 Fixed	 Fixed	 Flip Top	 Fixed
Solid Core Top ▶ 28"H	AL3636MC U.S. Canada	AL3939MC U.S. Canada	AL3939FMC U.S. Canada	AL4848MC U.S. Canada

Convex Vinyl Edge

Grade 1 Laminate	\$ 575	\$ 604	\$ 601	\$ 631	\$ 717	\$ 753	\$ 601	\$ 631	\$ 604	\$ 634
Grade 2 Laminate	\$ 608	\$ 638	\$ 648	\$ 680	\$ 763	\$ 801	\$ 648	\$ 680	\$ 666	\$ 699
Wood Veneer	\$1039	\$1091	\$1199	\$1259	\$1315	\$1381	\$1199	\$1259	\$1218	\$1279

Bullnose Wood Edge

Grade 1 Laminate	\$1288	\$1352	\$1304	\$1369	\$1421	\$1492	\$1304	\$1369	\$1275	\$1339
Grade 2 Laminate	\$1322	\$1388	\$1352	\$1420	\$1467	\$1540	\$1352	\$1420	\$1336	\$1403
Wood Veneer	\$1752	\$1840	\$1902	\$1997	\$2018	\$2119	\$1902	\$1997	\$1888	\$1982

	AL3636UMC U.S. Canada	AL3939UMC U.S. Canada	AL3939UFMC U.S. Canada	AL4242UMC U.S. Canada	AL4848UMC U.S. Canada
--	--	--	---	--	--

Cast Urethane Edge

Grade 1 Laminate	\$ 882	\$ 926	\$ 995	\$1045	\$1111	\$1167	\$ 995	\$1045	\$1036	\$1088
Grade 2 Laminate	\$ 916	\$ 962	\$1042	\$1094	\$1159	\$1217	\$1042	\$1094	\$1098	\$1153

30"L, 36"L x 24"W and 36"L x 30"W with 27"W Base

► Master Class, pages 42, 139

► Product weights, page 482

Standard Includes

- Height: 28.5"H
- Top: 1.25" particle board core with laminate or straight-grain wood veneer surface
- Edge: convex vinyl, bullnose solid wood edge or self-skinning cast urethane.
- Nesting base: 2.5"-diameter steel column and nesting, glass-filled nylon feet with single textured powder coat color
- Fixed top with black steel spider or flip top to allow tables to nest for compact storage
- Patented black flip top mechanism with easy, self-locking chrome release handle
- 2.36"-diameter, locking, dual-wheel casters: black plastic
- Shipped K.D.

Required to Specify

- Product number
- Powder coat color selection for base:
 - 7261 Concrete Texture
 - 7260 Highway Texture
 - 7269 Storm Texture
 - 7268 Tux Texture
- Laminate or wood color number and name for top
- Edge selection:
 - Convex vinyl edge: colors at right
 - Cast urethane edge: colors at right
 - Bullnose solid wood edge

- Vinyl color number and name for convex vinyl edge, if selected: 6000 Black, 6655 Warm White, 6609 Smoke, or 6607 Woodrose
- Vinyl color number and name for cast urethane edge, if selected: 6000 Black, 6655 Warm White, 6609 Smoke, or 6607 Woodrose
- Wood color number and name for wood edge, if selected
Exception: Wood edge will match the surface of a wood veneer top, so no color specification is needed.
Tip: If you specify a wood edge on a top with wood grain laminate, the edge and top may not match.
- Options: if selected (see list)
► *Surface Materials*, page 52

Options

- **Stain-to-match** ► page 47
- **Glides**
Glides with 0.5" adjustability range factory-installed in place of casters: black. Glides are the same height as casters.
No cost
Specify by deleting suffix **C** from the product number.

Accessories

- **Casters** ► page 157
- **Glides** ► page 157

	24" x 30"		24" x 36"		30" x 36"	
Veneer direction 						
	Fixed	Flip Top	Fixed	Flip Top	Fixed	Flip Top
Solid Core Top ► 28"H	AL2430SC U.S. Canada	AL2430FSC U.S. Canada	AL2436SC U.S. Canada	AL2436FSC U.S. Canada	AL3036SC U.S. Canada	AL3036FSC U.S. Canada

Convex Vinyl Edge

Grade 1 Laminate	\$ 526	\$ 552	\$ 643	\$ 675	\$ 539	\$ 566	\$ 654	\$ 687	\$ 558	\$ 586	\$ 674	\$ 708
Grade 2 Laminate	\$ 545	\$ 572	\$ 661	\$ 694	\$ 562	\$ 590	\$ 677	\$ 711	\$ 587	\$ 616	\$ 703	\$ 738
Wood Veneer	\$ 990	\$ 1040	\$ 1106	\$ 1161	\$ 1000	\$ 1050	\$ 1117	\$ 1173	\$ 1137	\$ 1194	\$ 1252	\$ 1315

Bullnose Wood Edge

Grade 1 Laminate	\$ 893	\$ 938	\$ 1010	\$ 1061	\$ 906	\$ 951	\$ 1020	\$ 1071	\$ 1040	\$ 1092	\$ 1156	\$ 1214
Grade 2 Laminate	\$ 912	\$ 958	\$ 1029	\$ 1080	\$ 929	\$ 975	\$ 1044	\$ 1096	\$ 1070	\$ 1124	\$ 1186	\$ 1245
Wood Veneer	\$ 1357	\$ 1425	\$ 1473	\$ 1547	\$ 1368	\$ 1436	\$ 1484	\$ 1558	\$ 1619	\$ 1700	\$ 1735	\$ 1822

	AL2430USC U.S. Canada	AL2430UFSC U.S. Canada	AL2436USC U.S. Canada	AL2436UFSC U.S. Canada	AL3036USC U.S. Canada	AL3036UFSC U.S. Canada
--	---------------------------------	----------------------------------	---------------------------------	----------------------------------	---------------------------------	----------------------------------

Cast Urethane Edge

Grade 1 Laminate	\$ 736	\$ 773	\$ 852	\$ 895	\$ 752	\$ 790	\$ 867	\$ 910	\$ 818	\$ 859	\$ 934	\$ 981
Grade 2 Laminate	\$ 756	\$ 794	\$ 872	\$ 916	\$ 775	\$ 814	\$ 890	\$ 935	\$ 848	\$ 890	\$ 964	\$ 1012

42"L, 48"L x 30"W and 36"W with 36"W Base

- ▶ Master Class, pages 42, 139
- ▶ Product weights, page 482

Standard Includes

- Height: 28.5"H
- Top: 1.25" particle board core with laminate or straight-grain wood veneer surface
- Edge: convex vinyl, bullnose solid wood edge or self-skinning cast urethane.
- Nesting base: 2.5"-diameter steel column and nesting, glass-filled nylon feet with single textured powder coat color
- Fixed top with black steel spider or flip top to allow tables to nest for compact storage
- Patented black flip top mechanism with easy, self-locking chrome release handle
- 2.36"-diameter, locking, dual-wheel casters: black plastic
- Shipped K.D.

Required to Specify

- Product number
- Powder coat color selection for base:
 - 7261 Concrete Texture
 - 7260 Highway Texture
 - 7269 Storm Texture
 - 7268 Tux Texture
- Laminate or wood color number and name for top
- Edge selection:
 - Convex vinyl edge: colors at right
 - Cast urethane edge: colors at right
 - Bullnose solid wood edge







- Vinyl color number and name for convex vinyl edge, if selected: 6000 Black, 6655 Warm White, 6609 Smoke, or 6607 Woodrose
- Vinyl color number and name for cast urethane edge, if selected: 6000 Black, 6655 Warm White, 6609 Smoke, or 6607 Woodrose
- Wood color number and name for wood edge, if selected
Exception: Wood edge will match the surface of a wood veneer top, so no color specification is needed.
Tip: If you specify a wood edge on a top with wood grain laminate, the edge and top may not match.
- Options: if selected (see list)
 - ▶ **Surface Materials**, page 52

Options

- **Stain-to-match** ▶ page 47
- **Glides**
Glides with 0.5" adjustability range factory-installed in place of casters: black . Glides are the same height as casters.
No cost
Specify by deleting suffix **C** from the product number.

Accessories

- **Casters** ▶ page 157

	30" x 42"		30" x 48"		36" x 42"		36" x 48"			
Veneer direction 										
	Fixed	Flip Top	Fixed	Fixed	Fixed					
Solid Core Top ▶ 28"H	AL3042MC U.S. Canada		AL3042FMC U.S. Canada		AL3048MC U.S. Canada		AL3642MC U.S. Canada		AL3648MC U.S. Canada	

Convex Vinyl Edge

Grade 1 Laminate	\$ 573	\$ 602	\$ 688	\$ 722	\$ 590	\$ 620	\$ 573	\$ 602	\$ 602	\$ 632
Grade 2 Laminate	\$ 606	\$ 636	\$ 722	\$ 758	\$ 628	\$ 659	\$ 614	\$ 645	\$ 648	\$ 680
Wood Veneer	\$1151	\$1209	\$1268	\$1331	\$1396	\$1466	\$1378	\$1447	\$1406	\$1476

Bullnose Wood Edge

Grade 1 Laminate	\$1056	\$1109	\$1171	\$1230	\$1142	\$1199	\$1124	\$1180	\$1152	\$1210
Grade 2 Laminate	\$1089	\$1143	\$1205	\$1265	\$1180	\$1239	\$1165	\$1223	\$1200	\$1260
Wood Veneer	\$1635	\$1717	\$1750	\$1838	\$1946	\$2043	\$1928	\$2024	\$1958	\$2056

	AL3042UMC U.S. Canada		AL3042UFMC U.S. Canada		AL3048UMC U.S. Canada		AL3642UMC U.S. Canada		AL3648UMC U.S. Canada	
--	--	--	---	--	--	--	--	--	--	--

Cast Urethane Edge

Grade 1 Laminate	\$ 846	\$ 888	\$ 962	\$1010	\$ 857	\$ 900	\$ 969	\$1017	\$ 979	\$1028
Grade 2 Laminate	\$ 880	\$ 924	\$ 995	\$1045	\$ 894	\$ 939	\$1010	\$1061	\$1026	\$1077

DESIGNED BY RADAR AND VECTA DESIGN TEAM

AULIAIT

30"- and 36"-Diameter with 27"W Base

- ▶ Master Class, pages 42, 139
- ▶ Product weights, page 482

Standard Includes

- Height: 33"H
- Top: 1.25" particle board core with laminate or straight-grain wood veneer surface
- Edge: convex vinyl, bullnose solid wood edge or self-skinning cast urethane.
- Nesting base: 2.5"-diameter steel column and nesting, glass-filled nylon feet with single textured powder coat color
- Fixed top with black steel spider or flip top to allow tables to nest for compact storage
- Patented black flip top mechanism with easy, self-locking chrome release handle
- 2.36"-diameter, locking, dual-wheel casters: black plastic
- Shipped K.D.

Required to Specify

- Product number
- Powder coat color selection for base:
 - 7261 Concrete Texture
 - 7260 Highway Texture
 - 7269 Storm Texture
 - 7268 Tux Texture
- Laminate or wood color number and name for top
- Edge selection:
 - Convex vinyl edge: colors at right
 - Cast urethane edge: colors at right
 - Bullnose solid wood edge

- Vinyl color number and name for convex vinyl edge, if selected: 6000 Black, 6655 Warm White, 6609 Smoke, or 6607 Woodrose
- Vinyl color number and name for cast urethane edge, if selected: 6000 Black, 6655 Warm White, 6609 Smoke, or 6607 Woodrose
- Wood color number and name for wood edge, if selected
Exception: Wood edge will match the surface of a wood veneer top, so no color specification is needed.
Tip: If you specify a wood edge on a top with wood grain laminate, the edge and top may not match.
- Options: if selected (see list)
▶ *Surface Materials*, page 52

Options

- **Stain-to-match** ▶ page 47
- **Glides**
Glides with 0.5" adjustability range factory-installed in place of casters: black. Glides are the same height as casters.
No cost
Specify by deleting suffix **C** from the product number.

Accessories

- **Casters** ▶ page 157
- **Glides** ▶ page 157

30"-Diameter



Fixed

ALW3000SC
U.S. Canada



Flip Top

ALW3000FSC
U.S. Canada

36"-Diameter



Fixed

ALW3600SC
U.S. Canada



Flip Top

ALW3600FSC
U.S. Canada

Veneer direction

Solid Core Top
▶ 33"H

Convex Vinyl Edge

	ALW3000SC U.S.	ALW3000SC Canada	ALW3000FSC U.S.	ALW3000FSC Canada	ALW3600SC U.S.	ALW3600SC Canada	ALW3600FSC U.S.	ALW3600FSC Canada
Grade 1 Laminate	\$ 544	\$ 571	\$ 660	\$ 693	\$ 580	\$ 609	\$ 696	\$ 731
Grade 2 Laminate	\$ 568	\$ 596	\$ 684	\$ 718	\$ 615	\$ 646	\$ 731	\$ 768
Wood Veneer	\$ 970	\$ 1019	\$ 1086	\$ 1140	\$ 986	\$ 1035	\$ 1101	\$ 1156

Bullnose Wood Edge

Grade 1 Laminate	\$ 1093	\$ 1148	\$ 1208	\$ 1268	\$ 1319	\$ 1385	\$ 1434	\$ 1506
Grade 2 Laminate	\$ 1117	\$ 1173	\$ 1232	\$ 1294	\$ 1354	\$ 1422	\$ 1470	\$ 1544
Wood Veneer	\$ 1518	\$ 1594	\$ 1635	\$ 1717	\$ 1724	\$ 1810	\$ 1840	\$ 1932

ALW3000USC
U.S. Canada

ALW3000UFSC
U.S. Canada

ALW3600USC
U.S. Canada

ALW3600UFSC
U.S. Canada

Cast Urethane Edge

Grade 1 Laminate	\$ 818	\$ 859	\$ 934	\$ 981	\$ 886	\$ 930	\$ 1000	\$ 1050
Grade 2 Laminate	\$ 842	\$ 884	\$ 958	\$ 1006	\$ 920	\$ 966	\$ 1036	\$ 1088

42- and 48"-Diameter with 36"W Base

- ▶ Master Class, pages 42, 139
- ▶ Product weights, page 482

Standard Includes

- Height: 33"H
- Top: 1.25" particle board core with laminate or straight-grain wood veneer surface
- Edge: convex vinyl, bullnose solid wood edge or self-skinning cast urethane.
- Nesting base: 2.5"-diameter steel column and nesting, glass-filled nylon feet with single textured powder coat color
- Fixed top with black steel spider or flip top to allow tables to nest for compact storage
- Patented black flip top mechanism with easy, self-locking chrome release handle
- 2.36"-diameter, locking, dual-wheel casters: black plastic
- Shipped K.D.

Required to Specify

- Product number
- Powder coat color selection for base:
 - 7261 Concrete Texture
 - 7260 Highway Texture
 - 7269 Storm Texture
 - 7268 Tux Texture
- Laminate or wood color number and name for top
- Edge selection:
 - Convex vinyl edge: colors at right
 - Cast urethane edge: colors at right
 - Bullnose solid wood edge

- Vinyl color number and name for convex vinyl edge, if selected: 6000 Black, 6655 Warm White, 6609 Smoke, or 6607 Woodrose
- Vinyl color number and name for cast urethane edge, if selected: 6000 Black, 6655 Warm White, 6609 Smoke, or 6607 Woodrose
- Wood color number and name for wood edge, if selected
Exception: Wood edge will match the surface of a wood veneer top, so no color specification is needed.
Tip: If you specify a wood edge on a top with wood grain laminate, the edge and top may not match.
- Options: if selected (see list)
 - ▶ *Surface Materials*, page 52

Options

- **Stain-to-match** ▶ page 47
- **Glides**
Glides with 0.5" adjustability range factory-installed in place of casters: black. Glides are the same height as casters.
No cost
Specify by deleting suffix **C** from the product number.

Accessories

- **Casters** ▶ page 157
- **Glides** ▶ page 157

Veneer direction  Solid Core Top ▶ 33"H	42"-Diameter  Fixed	 Flip Top	48"-Diameter  Fixed
	ALW4200MC U.S. Canada	ALW4200FMC U.S. Canada	ALW4800MC U.S. Canada

Convex Vinyl Edge

Grade 1 Laminate	\$ 610	\$ 641	\$ 727	\$ 763	\$ 615	\$ 646
Grade 2 Laminate	\$ 657	\$ 690	\$ 774	\$ 813	\$ 676	\$ 710
Wood Veneer	\$1230	\$1292	\$1346	\$1413	\$1280	\$1344

Bullnose Wood Edge

Grade 1 Laminate	\$1370	\$1439	\$1486	\$1560	\$1406	\$1476
Grade 2 Laminate	\$1418	\$1489	\$1533	\$1610	\$1467	\$1540
Wood Veneer	\$1990	\$2090	\$2106	\$2211	\$2073	\$2177

ALW4200UMC U.S. Canada	ALW4200UFMC U.S. Canada	ALW4800UMC U.S. Canada
---	--	---

Cast Urethane Edge

Grade 1 Laminate	\$ 999	\$1049	\$1116	\$1172	\$1046	\$1098
Grade 2 Laminate	\$1048	\$1100	\$1164	\$1222	\$1108	\$1163

DESIGNED BY RADAR AND VECTA DESIGN TEAM

AULAIT

24" and 30" Square with 27"W Base

- ▶ Master Class, pages 42, 139
- ▶ Product weights, page 482

Standard Includes

- Height: 33"H
- Top: 1.25" particle board core with laminate or straight-grain wood veneer surface
- Edge: convex vinyl, bullnose solid wood edge or self-skinning cast urethane.
- Nesting base: 2.5"-diameter steel column and nesting, glass-filled nylon feet with single textured powder coat color
- Fixed top with black steel spider or flip top to allow tables to nest for compact storage
- Patented black flip top mechanism with easy, self-locking chrome release handle
- 2.36"-diameter, locking, dual-wheel casters: black plastic
- Shipped K.D.

Required to Specify

- Product number
- Powder coat color selection for base:
 - 7261 Concrete Texture
 - 7260 Highway Texture
 - 7269 Storm Texture
 - 7268 Tux Texture
- Laminate or wood color number and name for top
- Edge selection:
 - Convex vinyl edge: colors at right
 - Cast urethane edge: colors at right
 - Bullnose solid wood edge

- Vinyl color number and name for convex vinyl edge, if selected: 6000 Black, 6655 Warm White, 6609 Smoke, or 6607 Woodrose
- Vinyl color number and name for cast urethane edge, if selected: 6000 Black, 6655 Warm White, 6609 Smoke, or 6607 Woodrose
- Wood color number and name for wood edge, if selected
Exception: Wood edge will match the surface of a wood veneer top, so no color specification is needed.
Tip: If you specify a wood edge on a top with wood grain laminate, the edge and top may not match.
- Options: if selected (see list)
 - ▶ **Surface Materials**, page 52

Options

- **Stain-to-match** ▶ page 47
- **Glides**
Glides with 0.5" adjustability range factory-installed in place of casters: black . Glides are the same height as casters.
No cost
Specify by deleting suffix **C** from the product number.

Accessories

- **Casters** ▶ page 157
- **Glides** ▶ page 157

24" x 24"



Fixed

ALW2424SC
U.S. Canada



Flip Top

ALW2424FSC
U.S. Canada

30" x 30"



Fixed

ALW3030SC
U.S. Canada



Flip Top

ALW3030FSC
U.S. Canada

Veneer direction

Solid Core Top
▶ 33"H

Convex Vinyl Edge

Grade 1 Laminate	\$ 525	\$ 551	\$ 642	\$ 674	\$ 541	\$ 568	\$ 656	\$ 689
Grade 2 Laminate	\$ 541	\$ 568	\$ 656	\$ 689	\$ 565	\$ 593	\$ 681	\$ 715
Wood Veneer	\$ 989	\$1038	\$1104	\$1159	\$1005	\$1055	\$1120	\$1176

Bullnose Wood Edge

Grade 1 Laminate	\$ 892	\$ 937	\$1009	\$1059	\$ 908	\$ 953	\$1023	\$1074
Grade 2 Laminate	\$ 908	\$ 953	\$1023	\$1074	\$ 932	\$ 979	\$1048	\$1100
Wood Veneer	\$1356	\$1424	\$1472	\$1546	\$1370	\$1439	\$1486	\$1560

ALW2424USC
U.S. Canada

ALW2424UFSC
U.S. Canada

ALW3030USC
U.S. Canada

ALW3030UFSC
U.S. Canada

Cast Urethane Edge

Grade 1 Laminate	\$ 721	\$ 757	\$ 837	\$ 879	\$ 834	\$ 876	\$ 950	\$ 998
Grade 2 Laminate	\$ 736	\$ 773	\$ 852	\$ 895	\$ 858	\$ 901	\$ 973	\$1022

36", 42", and 48" Square with 36"W Base

- ▶ Master Class, pages 42, 139
- ▶ Product weights, page 482

Standard Includes

- Height: 33"H
- Top: 1.25" particle board core with laminate or straight-grain wood veneer surface
- Edge: convex vinyl, bullnose solid wood edge or self-skinning cast urethane.
- Nesting base: 2.5"-diameter steel column and nesting, glass-filled nylon feet with single textured powder coat color
- Fixed top with black steel spider or flip top to allow tables to nest for compact storage
- Patented black flip top mechanism with easy, self-locking chrome release handle
- 2.36"-diameter, locking, dual-wheel casters: black plastic
- Shipped K.D.

Required to Specify

- Product number
- Powder coat color selection for base:
 - 7261 Concrete Texture
 - 7260 Highway Texture
 - 7269 Storm Texture
 - 7268 Tux Texture
- Laminate or wood color number and name for top
- Edge selection:
 - Convex vinyl edge: colors at right
 - Cast urethane edge: colors at right
 - Bullnose solid wood edge

- Vinyl color number and name for convex vinyl edge, if selected: 6000 Black, 6655 Warm White, 6609 Smoke, or 6607 Woodrose
- Vinyl color number and name for cast urethane edge, if selected: 6000 Black, 6655 Warm White, 6609 Smoke, or 6607 Woodrose
- Wood color number and name for wood edge, if selected
Exception: Wood edge will match the surface of a wood veneer top, so no color specification is needed.
Tip: If you specify a wood edge on a top with wood grain laminate, the edge and top may not match.
- Options: if selected (see list)
 - ▶ **Surface Materials**, page 52







Options

- **Stain-to-match** ▶ page 47
- **Glides**
Glides with 0.5" adjustability range factory-installed in place of casters: black. Glides are the same height as casters.
No cost
Specify by deleting suffix **C** from the product number.

Accessories

- **Casters** ▶ page 157
- **Glides** ▶ page 157

DESIGNED BY RADAR AND VECTA DESIGN TEAM

	36" x 36"		42" x 42"		48" x 48"	
Veneer direction 						
Solid Core Top ▶ 33"H	ALW3636MC U.S. Canada	ALW3636FMC U.S. Canada	ALW4242MC U.S. Canada	ALW4242FMC U.S. Canada	ALW4848MC U.S. Canada	

Convex Vinyl Edge

Grade 1 Laminate	\$ 590	\$ 620	\$ 706	\$ 741	\$ 617	\$ 648	\$ 732	\$ 769	\$ 620	\$ 651
Grade 2 Laminate	\$ 624	\$ 655	\$ 739	\$ 776	\$ 664	\$ 697	\$ 779	\$ 818	\$ 681	\$ 715
Wood Veneer	\$1056	\$1109	\$1171	\$1230	\$1213	\$1274	\$1329	\$1395	\$1232	\$1294

Bullnose Wood Edge

Grade 1 Laminate	\$1303	\$1368	\$1420	\$1491	\$1320	\$1386	\$1435	\$1507	\$1290	\$1355
Grade 2 Laminate	\$1337	\$1404	\$145j152							
3	\$1526	\$1367	\$1435	\$1483	\$1557	\$1351	\$1419			
Wood Veneer	\$1769	\$1857	\$1884	\$1978	\$1918	\$2014	\$2032	\$2134	\$1903	\$1998

	ALW3636UMC U.S. Canada	ALW3636UFMC U.S. Canada	ALW4242UMC U.S. Canada	ALW4242UFMC U.S. Canada	ALW4848UMC U.S. Canada
--	---	--	---	--	---

Convex Vinyl Edge

Grade 1 Laminate	\$ 898	\$ 943	\$1013	\$1064	\$1011	\$1062	\$1126	\$1182	\$1052	\$1105
Grade 2 Laminate	\$ 932	\$ 979	\$1048	\$1100	\$1058	\$1111	\$1173	\$1232	\$1114	\$1170

30"L, 36"L x 24"W and 36"L x 30"W with 27"W Base

- ▶ Master Class, pages 42, 139
- ▶ Product weights, page 482

Standard Includes

- Height: 33"H
- Top: 1.25" particle board core with laminate or straight-grain wood veneer surface
- Edge: convex vinyl, bullnose solid wood edge or self-skinning cast urethane.
- Nesting base: 2.5"-diameter steel column and nesting, glass-filled nylon feet with single textured powder coat color
- Fixed top with black steel spider or flip top to allow tables to nest for compact storage
- Patented black flip top mechanism with easy, self-locking chrome release handle
- 2.36"-diameter, locking, dual-wheel casters: black plastic
- Shipped K.D.

Required to Specify

- Product number
- Powder coat color selection for base:
 - 7261 Concrete Texture
 - 7260 Highway Texture
 - 7269 Storm Texture
 - 7268 Tux Texture
- Laminate or wood color number and name for top
- Edge selection:
 - Convex vinyl edge: colors at right
 - Cast urethane edge: colors at right
 - Bullnose solid wood edge

- Vinyl color number and name for convex vinyl edge, if selected: 6000 Black, 6655 Warm White, 6609 Smoke, or 6607 Woodrose
- Vinyl color number and name for cast urethane edge, if selected: 6000 Black, 6655 Warm White, 6609 Smoke, or 6607 Woodrose
- Wood color number and name for wood edge, if selected
Exception: Wood edge will match the surface of a wood veneer top, so no color specification is needed.
Tip: If you specify a wood edge on a top with wood grain laminate, the edge and top may not match.
- Options: if selected (see list)
 - ▶ Surface Materials, page 52

Options

- **Stain-to-match** ▶ page 47
- **Glides**
Glides with 0.5" adjustability range factory-installed in place of casters: black. Glides are the same height as casters.
No cost
Specify by deleting suffix **C** from the product number.

Accessories

- **Casters** ▶ page 157
- **Glides** ▶ page 157

Veneer direction	24" x 30"		24" x 36"		30" x 36"	
	Fixed	Flip Top	Fixed	Flip Top	Fixed	Flip Top
Solid Core Top ▶ 33"H	ALW2430SC U.S. Canada	ALW2430FSC U.S. Canada	ALW2436SC U.S. Canada	ALW2436FSC U.S. Canada	ALW3036SC U.S. Canada	ALW3036FSC U.S. Canada

Convex Vinyl Edge

Grade 1 Laminate	\$ 542	\$ 569	\$ 657	\$ 690	\$ 553	\$ 581	\$ 669	\$ 702	\$ 573	\$ 602	\$ 688	\$ 722
Grade 2 Laminate	\$ 562	\$ 590	\$ 677	\$ 711	\$ 577	\$ 606	\$ 693	\$ 728	\$ 602	\$ 632	\$ 718	\$ 754
Wood Veneer	\$1006	\$1056	\$1121	\$1177	\$1016	\$1067	\$1132	\$1189	\$1151	\$1209	\$1268	\$1331

Bullnose Wood Edge

Grade 1 Laminate	\$ 909	\$ 954	\$1024	\$1075	\$ 920	\$ 966	\$1036	\$1088	\$1056	\$1109	\$1171	\$1230
Grade 2 Laminate	\$ 929	\$ 975	\$1044	\$1096	\$ 943	\$ 990	\$1059	\$1112	\$1085	\$1139	\$1201	\$1261
Wood Veneer	\$1373	\$1442	\$1487	\$1561	\$1383	\$1452	\$1499	\$1574	\$1635	\$1717	\$1750	\$1838

	ALW2430USC U.S. Canada	ALW2430UFSC U.S. Canada	ALW2436USC U.S. Canada	ALW2436UFSC U.S. Canada	ALW3036USC U.S. Canada	ALW3036UFSC U.S. Canada
--	---	--	---	--	---	--

Cast Urethane Edge

Grade 1 Laminate	\$ 752	\$ 790	\$ 867	\$ 910	\$ 768	\$ 806	\$ 883	\$ 927	\$ 834	\$ 876	\$ 950	\$ 998
Grade 2 Laminate	\$ 772	\$ 811	\$ 886	\$ 930	\$ 791	\$ 831	\$ 907	\$ 952	\$ 862	\$ 905	\$ 978	\$1027

42"L, 48"L x 30"W and 36"W with 36"W Base

- ▶ Master Class, pages 42, 139
- ▶ Product weights, page 482

Standard Includes

- Height: 33"H
- Top: 1.25" particle board core with laminate or straight-grain wood veneer surface
- Edge: convex vinyl, bullnose solid wood edge or self-skinning cast urethane.
- Nesting base: 2.5"-diameter steel column and nesting, glass-filled nylon feet with single textured powder coat color
- Fixed top with black steel spider or flip top to allow tables to nest for compact storage
- Patented black flip top mechanism with easy, self-locking chrome release handle
- 2.36"-diameter, locking, dual-wheel casters: black plastic
- Shipped K.D.

Required to Specify

- Product number
- Powder coat color selection for base:
 - 7261 Concrete Texture
 - 7260 Highway Texture
 - 7269 Storm Texture
 - 7268 Tux Texture
- Laminate or wood color number and name for top
- Edge selection:
 - Convex vinyl edge: colors at right
 - Cast urethane edge: colors at right
 - Bullnose solid wood edge

- Vinyl color number and name for convex vinyl edge, if selected: 6000 Black, 6655 Warm White, 6609 Smoke, or 6607 Woodrose
- Vinyl color number and name for cast urethane edge, if selected: 6000 Black, 6655 Warm White, 6609 Smoke, or 6607 Woodrose
- Wood color number and name for wood edge, if selected
Exception: Wood edge will match the surface of a wood veneer top, so no color specification is needed.
Tip: If you specify a wood edge on a top with wood grain laminate, the edge and top may not match.
- Options: if selected (see list)
 - ▶ **Surface Materials**, page 52





Options

- **Stain-to-match** ▶ page 47
- **Glides**
Glides with 0.5" adjustability range factory-installed in place of casters: black . Glides are the same height as casters.
No cost
Specify by deleting suffix **C** from the product number.

Accessories

- **Casters** ▶ page 157
- **Glides** ▶ page 157

DESIGNED BY RADAR AND VECTA DESIGN TEAM

	30" x 42"		30" x 48"		36" x 42"		36" x 48"	
Veneer direction 								
	Fixed		Flip Top		Fixed		Fixed	
Solid Core Top ▶ 33"H	ALW3042MC U.S. Canada	ALW3042FMC U.S. Canada	ALW3048MC U.S. Canada	ALW3642MC U.S. Canada	ALW3642FMC U.S. Canada	ALW3648MC U.S. Canada	ALW3648MC U.S. Canada	ALW3648MC U.S. Canada

Convex Vinyl Edge

Grade 1 Laminate	\$ 588	\$ 617	\$ 704	\$ 739	\$ 605	\$ 635	\$ 588	\$ 617	\$ 704	\$ 739	\$ 619	\$ 650
Grade 2 Laminate	\$ 622	\$ 653	\$ 737	\$ 774	\$ 645	\$ 677	\$ 628	\$ 659	\$ 744	\$ 781	\$ 665	\$ 698
Wood Veneer	\$1167	\$1225	\$1282	\$1346	\$1409	\$1479	\$1394	\$1464	\$1509	\$1584	\$1423	\$1494

Bullnose Wood Edge

Grade 1 Laminate	\$1071	\$1125	\$1187	\$1246	\$1156	\$1214	\$1140	\$1197	\$1254	\$1317	\$1169	\$1227
Grade 2 Laminate	\$1104	\$1159	\$1221	\$1282	\$1221	\$1282	\$1180	\$1239	\$1296	\$1361	\$1215	\$1276
Wood Veneer	\$1649	\$1731	\$1766	\$1854	\$1766	\$1854	\$1944	\$2041	\$2059	\$2162	\$1973	\$2072

	ALW3042UMC U.S. Canada	ALW3042UFMC U.S. Canada	ALW3048UMC U.S. Canada	ALW3642UMC U.S. Canada	ALW3642UFMC U.S. Canada	ALW3648UMC U.S. Canada
--	---	--	---	---	--	---

Cast Urethane Edge

Grade 1 Laminate	\$ 861	\$ 904	\$ 977	\$ 1026	\$ 872	\$ 916	\$ 986	\$ 1035	\$ 1101	\$ 1156	\$ 995	\$ 1045
Grade 2 Laminate	\$ 894	\$ 939	\$ 1011	\$ 1062	\$ 910	\$ 956	\$ 1026	\$ 1077	\$ 1142	\$ 1199	\$ 1042	\$ 1094

30"- and 36"-Diameter with 27"W Base

- ▶ Master Class, pages 42, 139
- ▶ Product weights, page 482

Standard Includes

- Height: 42"H
- Top: 1.25" particle board core with laminate or straight-grain wood veneer surface
- Edge: convex vinyl, bullnose solid wood edge or self-skinning cast urethane.
- Nesting base: 2.5"-diameter steel column and nesting, glass-filled nylon feet with single textured powder coat color
- Fixed top with black steel spider or flip top to allow tables to nest for compact storage
- Patented black flip top mechanism with easy, self-locking chrome release handle
- 2.36"-diameter, locking, dual-wheel casters: black plastic
- Shipped K.D.

Required to Specify

- Product number
- Powder coat color selection for base:
 - 7261 Concrete Texture
 - 7260 Highway Texture
 - 7269 Storm Texture
 - 7268 Tux Texture
- Laminate or wood color number and name for top
- Edge selection:
 - Convex vinyl edge: colors at right
 - Cast urethane edge: colors at right
 - Bullnose solid wood edge

- Vinyl color number and name for convex vinyl edge, if selected: 6000 Black, 6655 Warm White, 6609 Smoke, or 6607 Woodrose
- Vinyl color number and name for cast urethane edge, if selected: 6000 Black, 6655 Warm White, 6609 Smoke, or 6607 Woodrose
- Wood color number and name for wood edge, if selected
Exception: Wood edge will match the surface of a wood veneer top, so no color specification is needed.
Tip: If you specify a wood edge on a top with wood grain laminate, the edge and top may not match.
- Options: if selected (see list)
▶ **Surface Materials**, page 52

Options

- **Stain-to-match** ▶ page 47
- **Glides**
Glides with 0.5" adjustability range factory-installed in place of casters: black. Glides are the same height as casters.
No cost
Specify by deleting suffix **C** from the product number.

Accessories

- **Casters** ▶ page 157
- **Glides** ▶ page 157

30"-Diameter



Fixed

ALB3000SC
U.S. Canada



Flip Top

ALB3000FSC
U.S. Canada

36"-Diameter



Fixed

ALB3600SC
U.S. Canada



Flip Top

ALB3600FSC
U.S. Canada

Veneer direction

Solid Core Top
▶ 42"H

Convex Vinyl Edge

	ALB3000SC	ALB3000FSC	ALB3600SC	ALB3600FSC
Grade 1 Laminate	\$ 565 \$ 593	\$ 681 \$ 715	\$ 601 \$ 631	\$ 717 \$ 753
Grade 2 Laminate	\$ 588 \$ 617	\$ 704 \$ 739	\$ 635 \$ 667	\$ 752 \$ 790
Wood Veneer	\$ 991 \$1041	\$1107 \$1162	\$1007 \$1057	\$1122 \$1178

Bullnose Wood Edge

	ALB3000SC	ALB3000FSC	ALB3600SC	ALB3600FSC
Grade 1 Laminate	\$1114 \$1170	\$1229 \$1290	\$1340 \$1407	\$1455 \$1528
Grade 2 Laminate	\$1137 \$1194	\$1252 \$1315	\$1375 \$1444	\$1490 \$1565
Wood Veneer	\$1539 \$1616	\$1656 \$1739	\$1745 \$1832	\$1861 \$1954

ALB3000USC
U.S. Canada

ALB3000UFSC
U.S. Canada

ALB3600USC
U.S. Canada

ALB3600UFSC
U.S. Canada

Cast Urethane Edge

	ALB3000USC	ALB3000UFSC	ALB3600USC	ALB3600UFSC
Grade 1 Laminate	\$ 839 \$ 881	\$ 955 \$1003	\$ 907 \$ 952	\$1022 \$1073
Grade 2 Laminate	\$ 863 \$ 906	\$ 979 \$1028	\$ 941 \$ 988	\$1057 \$1110

24" and 30" Square with 27" Base

- ▶ Master Class, pages 42, 139
- ▶ Product weights, page 482

Standard Includes

- Height: 42"H
- Top: 1.25" particle board core with laminate or straight-grain wood veneer surface
- Edge: convex vinyl, bullnose solid wood edge or self-skinning cast urethane.
- Nesting base: 2.5"-diameter steel column and nesting, glass-filled nylon feet with single textured powder coat color
- Fixed top with black steel spider or flip top to allow tables to nest for compact storage
- Patented black flip top mechanism with easy, self-locking chrome release handle
- 2.36"-diameter, locking, dual-wheel casters: black plastic
- Shipped K.D.

Required to Specify

- Product number
- Powder coat color selection for base:
 - 7261 Concrete Texture
 - 7260 Highway Texture
 - 7269 Storm Texture
 - 7268 Tux Texture
- Laminate or wood color number and name for top
- Edge selection:
 - Convex vinyl edge: colors at right
 - Cast urethane edge: colors at right
 - Bullnose solid wood edge

- Vinyl color number and name for convex vinyl edge, if selected: 6000 Black, 6655 Warm White, 6609 Smoke, or 6607 Woodrose
- Vinyl color number and name for cast urethane edge, if selected: 6000 Black, 6655 Warm White, 6609 Smoke, or 6607 Woodrose
- Wood color number and name for wood edge, if selected
Exception: Wood edge will match the surface of a wood veneer top, so no color specification is needed.
Tip: If you specify a wood edge on a top with wood grain laminate, the edge and top may not match.
- Options: if selected (see list)
▶ *Surface Materials*, page 52

Options

- **Stain-to-match** ▶ page 47
- **Glides**
Glides with 0.5" adjustability range factory-installed in place of casters: black. Glides are the same height as casters.
No cost
Specify by deleting suffix **C** from the product number.

Accessories

- **Casters** ▶ page 157
- **Glides** ▶ page 157

DESIGNED BY RADAR AND VECTA DESIGN TEAM

	24" x 24"		30" x 30"	
Veneer direction 				
	Fixed	Flip Top	Fixed	Flip Top
Solid Core Top ▶ 42"H	ALB2424SC U.S. Canada	ALB2424FSC U.S. Canada	ALB3030SC U.S. Canada	ALB3030FSC U.S. Canada

Convex Vinyl Edge

Grade 1 Laminate	\$ 545	\$ 572	\$ 661	\$ 694	\$ 562	\$ 590	\$ 677	\$ 711
Grade 2 Laminate	\$ 562	\$ 590	\$ 677	\$ 711	\$ 584	\$ 613	\$ 700	\$ 735
Wood Veneer	\$1009	\$1059	\$1124	\$1180	\$1024	\$1075	\$1141	\$1198

Bullnose Wood Edge

Grade 1 Laminate	\$ 912	\$ 958	\$1029	\$1080	\$ 929	\$ 975	\$1044	\$1096
Grade 2 Laminate	\$ 929	\$ 975	\$1044	\$1096	\$ 952	\$1000	\$1067	\$1120
Wood Veneer	\$1376	\$1445	\$1491	\$1566	\$1392	\$1462	\$1507	\$1582

	ALB2424USC U.S. Canada	ALB2424UFSC U.S. Canada	ALB3030USC U.S. Canada	ALB3030UFSC U.S. Canada
--	---	--	---	--

Cast Urethane Edge

Grade 1 Laminate	\$ 740	\$ 777	\$ 857	\$ 900	\$ 855	\$ 898	\$ 970	\$1019
Grade 2 Laminate	\$ 757	\$ 795	\$ 873	\$ 917	\$ 879	\$ 923	\$ 994	\$1044

36" Square with 36"W Base

- ▶ Master Class, pages 42, 139
- ▶ Product weights, page 482

Standard Includes

- Height: 42"H
- Top: 1.25" particle board core with laminate or straight-grain wood veneer surface
- Edge: convex vinyl, bullnose solid wood edge or self-skinning cast urethane.
- Nesting base: 2.5"-diameter steel column and nesting, glass-filled nylon feet with single textured powder coat color
- Fixed top with black steel spider or flip top to allow tables to nest for compact storage
- Patented black flip top mechanism with easy, self-locking chrome release handle
- 2.36"-diameter, locking, dual-wheel casters: black plastic
- Shipped K.D.

Required to Specify

- Product number
- Powder coat color selection for base:
 - 7261 Concrete Texture
 - 7260 Highway Texture
 - 7269 Storm Texture
 - 7268 Tux Texture
- Laminate or wood color number and name for top
- Edge selection:
 - Convex vinyl edge: colors at right
 - Cast urethane edge: colors at right
 - Bullnose solid wood edge

- Vinyl color number and name for convex vinyl edge, if selected: 6000 Black, 6655 Warm White, 6609 Smoke, or 6607 Woodrose
- Vinyl color number and name for cast urethane edge, if selected: 6000 Black, 6655 Warm White, 6609 Smoke, or 6607 Woodrose
- Wood color number and name for wood edge, if selected
Exception: Wood edge will match the surface of a wood veneer top, so no color specification is needed.
Tip: If you specify a wood edge on a top with wood grain laminate, the edge and top may not match.
- Options: if selected (see list)
▶ *Surface Materials*, page 52

Options

- **Stain-to-match** ▶ page 47
- **Glides**
Glides with 0.5" adjustability range factory-installed in place of casters: black. Glides are the same height as casters.
No cost
Specify by deleting suffix **C** from the product number.

Accessories

- **Casters** ▶ page 157
- **Glides** ▶ page 157

36" x 36"



Fixed

ALB3636MC
U.S. Canada



Flip Top

ALB3636FMC
U.S. Canada

Veneer direction

Solid Core Top
▶ 42"H

Convex Vinyl Edge

Grade 1 Laminate	\$ 609	\$ 639	\$ 726	\$ 762
Grade 2 Laminate	\$ 645	\$ 677	\$ 760	\$ 798
Wood Veneer	\$1075	\$1129	\$1191	\$1251

Bullnose Wood Edge

Grade 1 Laminate	\$1323	\$1389	\$1439	\$1511
Grade 2 Laminate	\$1358	\$1426	\$1474	\$1548
Wood Veneer	\$1789	\$1878	\$1904	\$1999

ALB3636UMC
U.S. Canada

ALB3636UFMC
U.S. Canada

Cast Urethane Edge

Grade 1 Laminate	\$ 918	\$ 964	\$1034	\$1086
Grade 2 Laminate	\$ 953	\$1001	\$1068	\$1121

Casters

- ▶ Master Class, page 141
- ▶ Product weights, page 482

Standard Includes

- Set of four locking casters for field retrofit: black

Required to Specify

- Product number



ALCASTER
U.S. **Canada**

\$109 *\$114*

Glides

- ▶ Master Class, page 141
- ▶ Product weights, page 482

Standard Includes

- Set of four glides for field retrofit: black

Required to Specify

- Product number



ALGLIDE
U.S. **Canada**

\$109 *\$114*

- ▶ Master Class, page 140
- ▶ Product weights, page 482

Standard Includes

- Height: 27.75"H
- Top: .5"-thick solid phenolic top with pattern color on both top and bottom ▶ page 140
- Edge: black
- Nesting base: 2.5"-diameter steel column and nesting, glass-filled nylon feet with single textured powder coat color
- Fixed top with black steel spider or flip top to allow tables to nest for compact storage
- Patented black flip top mechanism with easy, self-locking chrome release handle
- 2.36"-diameter, locking, dual-wheel casters: black plastic
- Shipped K.D.

Required to Specify

- Product number
- Powder coat color selection for base:
 - 7261 Concrete Texture
 - 7260 Highway Texture
 - 7269 Storm Texture
 - 7268 Tux Texture
- Phenolic pattern color number and name:
 - 2131 Mellowtone
 - 2132 White
 - 2133 Storm Gray
- Options: if selected (see list)

Options

- **Glides**
Glides with 0.5" adjustability range factory-installed in place of casters: black . Glides are the same height as casters.
No cost
Specify by deleting suffix **C** from the product number.

Accessories

- **Casters** ▶ page 166
- **Glides** ▶ page 166

30"-Diameter



Fixed

AL3000PSC
U.S. **Canada**



Flip Top

AL3000PFSC
U.S. **Canada**

36"-Diameter



Fixed

AL3600PSC
U.S. **Canada**



Flip Top

AL3600PFSC
U.S. **Canada**

Solid Phenolic Top
▶ 27.75"H

27"W Base

\$ 586 **\$ 615**

\$ 701 **\$ 736**

\$ 718 **\$ 754**

\$ 834 **\$ 876**

42"-Diameter



Fixed

AL4200PMC
U.S. **Canada**

48"-Diameter



Fixed

AL4800PMC
U.S. **Canada**

36"W Base

\$ 729 **\$ 765**

\$ 734 **\$ 771**

- ▶ Master Class, page 140
- ▶ Product weights, page 482

Standard Includes

- Height: 27.75"H
- Top: .5"-thick solid phenolic top with pattern color on both top and bottom ▶ page 140
- Edge: black
- Nesting base: 2.5"-diameter steel column and nesting, glass-filled nylon feet with single textured powder coat color
- Fixed top with black steel spider or flip top to allow tables to nest for compact storage
- Patented black flip top mechanism with easy, self-locking chrome release handle
- 2.36"-diameter, locking, dual-wheel casters: black plastic
- Shipped K.D.

Required to Specify











- Product number
- Powder coat color selection for base:
 - 7261 Concrete Texture
 - 7260 Highway Texture
 - 7269 Storm Texture
 - 7268 Tux Texture
- Phenolic pattern color number and name:
 - 2131 Mellowtone
 - 2132 White
 - 2133 Storm Gray
- Options: if selected (see list)

Options

- **Glides**
Glides with 0.5" adjustability range factory-installed in place of casters: black . Glides are the same height as casters.
No cost
Specify by deleting suffix **C** from the product number.

Accessories

- **Castors** ▶ page 166
- **Glides** ▶ page 166

	24" x 24"		30" x 30"		36" x 36"		39" x 39"		42" x 42"		48" x 48"	
												
	Fixed	Flip Top	Fixed	Flip Top	Fixed	Flip Top	Fixed	Flip Top	Fixed	Fixed		
Solid Phenolic Top ▶ 27.75"H	AL2424PSC U.S. Canada		AL2424PFSC U.S. Canada		AL3030PSC U.S. Canada		AL3030PFSC U.S. Canada		AL3636PMC U.S. Canada		AL3939PMC U.S. Canada	
27"W Base												
	\$ 567	\$ 595	\$ 683	\$ 717	\$ 597	\$ 627	\$ 712	\$ 748				
36"W Base												
	\$ 731	\$ 768			\$ 742	\$ 779	\$ 858	\$ 901				
36"W Base												
	\$ 740	\$ 777			\$ 739	\$ 776						

- ▶ Master Class, pages 90
- ▶ Product weights, page 482

Standard Includes

- Height: 27.75"H
- Top: .5"-thick solid phenolic top with pattern color on both top and bottom ▶ page 140
- Edge: black.
- Nesting base: 2.5"-diameter steel column and nesting, glass-filled nylon feet with single textured powder coat color
- Fixed top with black steel spider or flip top to allow tables to nest for compact storage
- Patented black flip top mechanism with easy, self-locking chrome release handle
- 2.36"-diameter, locking, dual-wheel casters: black plastic
- Shipped K.D.

Required to Specify







- Product number
- Powder coat color selection for base:
 - 7261 Concrete Texture
 - 7260 Highway Texture
 - 7269 Storm Texture
 - 7268 Tux Texture
- Phenolic pattern color number and name:
 - 2131 Mellowtone
 - 2132 White
 - 2133 Storm Gray
- Options: if selected (see list)







Options

- **Glides**
Glides with 0.5" adjustability range factory-installed in place of casters: black . Glides are the same height as casters.
No cost
Specify by deleting suffix **C** from the product number.

Accessories

- **Casters** ▶ page 166
- **Glides** ▶ page 166

	24" x 30"		24" x 36"		30" x 36"							
												
	Fixed	Flip Top	Fixed	Flip Top	Fixed	Flip Top						
Solid Phenolic Top ▶ 27.75"H	AL2430PSC U.S. Canada	AL2430PFSC U.S. Canada	AL2436PSC U.S. Canada	AL2436PFSC U.S. Canada	AL3036PSC U.S. Canada	AL3036PFSC U.S. Canada						
27"W Base	\$ 584	\$ 613	\$ 700	\$ 735	\$ 597	\$ 627	\$ 712	\$ 748	\$ 705	\$ 740	\$ 821	\$ 862

	30" x 42"		30" x 48"		36" x 42"		36" x 48"					
												
	Fixed	Flip Top	Fixed	Flip Top	Fixed	Flip Top						
Solid Phenolic Top ▶ 27.75"H	AL3042PMC U.S. Canada	AL3042PFMC U.S. Canada	AL3048PMC U.S. Canada	AL3048PFMC U.S. Canada	AL3642PMC U.S. Canada	AL3642PFMC U.S. Canada	AL3648PMC U.S. Canada	AL3648PFMC U.S. Canada				
36"W Base	\$ 630	\$ 662	\$ 747	\$ 784	\$ 648	\$ 680	\$ 704	\$ 739	\$ 731	\$ 768		

- ▶ Master Class, page 140
- ▶ Product weights, page 482

Standard Includes

- Height: 32.25"H
- Top: .5"-thick solid phenolic top with pattern color on both top and bottom ▶ page 140
- Edge: black
- Nesting base: 2.5"-diameter steel column and nesting, glass-filled nylon feet with single textured powder coat color
- Fixed top with black steel spider or flip top to allow tables to nest for compact storage
- Patented black flip top mechanism with easy, self-locking chrome release handle
- 2.36"-diameter, locking, dual-wheel casters: black plastic
- Shipped K.D.

Required to Specify





- Product number
- Powder coat color selection for base:
 - 7261 Concrete Texture
 - 7260 Highway Texture
 - 7269 Storm Texture
 - 7268 Tux Texture
- Phenolic pattern color number and name:
 - 2131 Mellowtone
 - 2132 White
 - 2133 Storm Gray
- Options: if selected (see list)



Options

- **Glides**
Glides with 0.5" adjustability range factory-installed in place of casters: black . Glides are the same height as casters.
No cost
Specify by deleting suffix **C** from the product number.

Accessories

- **Castors** ▶ page 166
- **Glides** ▶ page 166

	30"-Diameter	36"-Diameter	
 Fixed	 Flip Top	 Fixed	 Flip Top
Solid Phenolic Top ▶ 32.25"H	ALW3000PSC U.S. Canada	ALW3000PFSC U.S. Canada	ALW3600PSC U.S. Canada
27"W Base			
	\$ 602 \$ 632	\$ 718 \$ 754	\$ 734 \$ 771
	\$ 850 \$ 893		

	42"-Diameter	48"-Diameter	
 Fixed	 Fixed	 Fixed	
Solid Phenolic Top ▶ 32.25"H	ALW4200PMC U.S. Canada	ALW4800PMC U.S. Canada	
36"W Base			
	\$ 746 \$ 783	\$ 751 \$ 789	

- ▶ Master Class, page 140
- ▶ Product weights, page 482

Standard Includes

- Height: 32.25"H
- Top: .5"-thick solid phenolic top with pattern color on both top and bottom ▶ page 140
- Edge: black
- Nesting base: 2.5"-diameter steel column and nesting, glass-filled nylon feet with single textured powder coat color
- Fixed top with black steel spider or flip top to allow tables to nest for compact storage
- Patented black flip top mechanism with easy, self-locking chrome release handle
- 2.36"-diameter, locking, dual-wheel casters: black plastic
- Shipped K.D.

Required to Specify

- Product number
- Powder coat color selection for base:
 - 7261 Concrete Texture
 - 7260 Highway Texture
 - 7269 Storm Texture
 - 7268 Tux Texture
- Phenolic pattern color number and name:
 - 2131 Mellowtone
 - 2132 White
 - 2133 Storm Gray
- Options: if selected (see list)











Options

• **Glides**

Glides with 0.5" adjustability range factory-installed in place of casters: black. Glides are the same height as casters.
 No cost
 Specify by deleting suffix **C** from the product number.

Accessories

- **Casters** ▶ page 166
- **Glides** ▶ page 166

	24" x 24"	30" x 30"		
				
	Fixed	Flip Top	Fixed	Flip Top
Solid Phenolic Top ▶ 32.25"H	ALW2424PSC U.S. Canada	ALW2424PFSC U.S. Canada	ALW3030PSC U.S. Canada	ALW3030PFSC U.S. Canada
27"W Base				
	\$ 583 \$ 612	\$ 699 \$ 734	\$ 612 \$ 643	\$ 728 \$ 764
	36" x 36"	39" x 39"		
				
	Fixed	Flip Top	Fixed	Flip Top
Solid Phenolic Top ▶ 32.25"H	ALW3636PMC U.S. Canada	ALW3636PFMC U.S. Canada	ALW3939PMC U.S. Canada	ALW3939PFMC U.S. Canada
36"W Base				
	\$ 747 \$ 784	\$ 862 \$ 905	\$ 758 \$ 796	\$ 874 \$ 918
	42" x 42"	48" x 48"		
				
	Fixed	Flip Top	Fixed	
Solid Phenolic Top ▶ 32.25"H	ALW4242PMC U.S. Canada	ALW4242PFMC U.S. Canada	ALW4848PMC U.S. Canada	
36"W Base				
	\$ 757 \$ 795	\$ 873 \$ 917	\$ 756 \$ 794	

- ▶ Master Class, page 140
- ▶ Product weights, page 482

Standard Includes

- Height: 32.25"H
- Top: .5"-thick solid phenolic top with pattern color on both top and bottom ▶ page 140
- Edge: black
- Nesting base: 2.5"-diameter steel column and nesting, glass-filled nylon feet with single textured powder coat color
- Fixed top with black steel spider or flip top to allow tables to nest for compact storage
- Patented black flip top mechanism with easy, self-locking chrome release handle
- 2.36"-diameter, locking, dual-wheel casters: black plastic
- Shipped K.D.

Required to Specify







- Product number
- Powder coat color selection for base:
 - 7261 Concrete Texture
 - 7260 Highway Texture
 - 7269 Storm Texture
 - 7268 Tux Texture
- Phenolic pattern color number and name:
 - 2131 Mellowtone
 - 2132 White
 - 2133 Storm Gray
- Options: if selected (see list)

Options







- **Glides**
Glides with 0.5" adjustability range factory-installed in place of casters: black . Glides are the same height as casters.
No cost
Specify by deleting suffix **C** from the product number.

Accessories

- **Castors** ▶ page 166
- **Glides** ▶ page 166

	24" x 30"		24" x 36"		30" x 36"	
						
	Fixed	Flip Top	Fixed	Flip Top	Fixed	Flip Top
Solid Phenolic Top ▶ 32.25"H	ALW2430PSC	ALW2430PFSC	ALW2436PSC	ALW2436PFSC	ALW3036PSC	ALW3036PFSC
	U.S. Canada	U.S. Canada	U.S. Canada	U.S. Canada	U.S. Canada	U.S. Canada

27"W Base						
	\$ 601	\$ 631	\$ 717	\$ 753	\$ 612	\$ 643
			\$ 728	\$ 764	\$ 721	\$ 757
					\$ 837	\$ 879

	30" x 42"		30" x 48"		36" x 42"		36" x 48"	
								
	Fixed	Flip Top	Fixed	Fixed	Flip Top	Fixed		
Solid Phenolic Top ▶ 32.25"H	ALW3042PMC	ALW3042PFMC	ALW3048PMC	ALW3642PMC	ALW3642PFMC	ALW3648PMC		
	U.S. Canada	U.S. Canada	U.S. Canada	U.S. Canada	U.S. Canada	U.S. Canada		

36"W Base								
	\$ 647	\$ 679	\$ 762	\$ 800	\$ 665	\$ 698	\$ 720	\$ 756
					\$ 836	\$ 878	\$ 747	\$ 784

- ▶ Master Class, page 140
- ▶ Product weights, page 482

Standard Includes

- Height: 41.25"H
- Top: .5"-thick solid phenolic top with pattern color on both top and bottom ▶ page 140
- Edge: black
- Nesting base: 2.5"-diameter steel column and nesting, glass-filled nylon feet with single textured powder coat color
- Fixed top with black steel spider or flip top to allow tables to nest for compact storage
- Patented black flip top mechanism with easy, self-locking chrome release handle
- 2.36"-diameter, locking, dual-wheel casters: black plastic
- Shipped K.D.

Required to Specify

- Product number
- Powder coat color selection for base:
 - 7260 Highway Texture
 - 7261 Concrete Texture
 - 7268 Tux Texture
 - 7269 Storm Texture
- Phenolic pattern color number and name:
 - 2131 Mellowtone
 - 2132 White
 - 2133 Storm Gray
- Options: if selected (see list)

Options

- **Glides**
Glides with 0.5" adjustability range factory-installed in place of casters: black . Glides are the same height as casters.
No cost
Specify by deleting suffix **C** from the product number.

Accessories

- **Casters** ▶ page 166
- **Glides** ▶ page 166

30"-Diameter



Fixed

ALB3000PSC
U.S. **Canada**



Flip Top

ALB3000PFSC
U.S. **Canada**

36"-Diameter



Fixed

ALB3600PSC
U.S. **Canada**



Flip Top

ALB3600PFSC
U.S. **Canada**

Solid Phenolic Top
▶ 41.25"H

27"W Base

\$ 623 **\$ 654**

\$ 738 **\$ 775**

\$ 755 **\$ 793**

\$ 870 **\$ 914**

- ▶ Master Class, page 140
- ▶ Product weights, page 482

Standard Includes

- Height: 41.25"H
- Top: .5"-thick solid phenolic top with pattern color on both top and bottom ▶ page 140
- Edge: black
- Nesting base: 2.5"-diameter steel column and nesting, glass-filled nylon feet with single textured powder coat color
- Fixed top with black steel spider or flip top to allow tables to nest for compact storage
- Patented black flip top mechanism with easy, self-locking chrome release handle
- 2.36"-diameter, locking, dual-wheel casters: black plastic
- Shipped K.D.

Required to Specify





- Product number
- Powder coat color selection for base:
 - 7261 Concrete Texture
 - 7260 Highway Texture
 - 7269 Storm Texture
 - 7268 Tux Texture
- Phenolic pattern color number and name:
 - 2131 Mellowtone
 - 2132 White
 - 2133 Storm Gray
- Options: if selected (see list)



Options

- **Glides**
Glides with 0.5" adjustability range factory-installed in place of casters: black . Glides are the same height as casters.
No cost
Specify by deleting suffix **C** from the product number.

Accessories

- **Casters** ▶ page 166
- **Glides** ▶ page 166

	24" x 24"		30" x 30"	
				
	Fixed	Flip Top	Fixed	Flip Top
Solid Phenolic Top ▶ 41.25"H	ALB2424PSC U.S. Canada	ALB2424PFSC U.S. Canada	ALB3030PSC U.S. Canada	ALB3030PFSC U.S. Canada
27"W Base	\$ 604 \$ 634	\$ 720 \$ 756	\$ 633 \$ 665	\$ 749 \$ 786

	36" x 36"	
		
	Fixed	Flip Top
Solid Phenolic Top ▶ 41.25"H	ALB3636PMC U.S. Canada	ALB3636PFMC U.S. Canada
36"W Base	\$ 768 \$ 806	\$ 883 \$ 927

Casters

- ▶ Master Class, page 141
- ▶ Product weights, page 482

Standard Includes

- Set of four locking casters for field retrofit: black

Required to Specify

- Product number



ALCASTER
 U.S. **Canada**

\$109 **\$114**

Glides

- ▶ Master Class, page 141
- ▶ Product weights, page 482

Standard Includes

- Set of four glides for field retrofit: black

Required to Specify

- Product number



ALGLIDE
 U.S. **Canada**

\$109 **\$114**