

Seating Specification Guide

What's New?

Spec News is available on in2.steelcase.com.
Go to *Specification Guides*, then *Current Release Spec News*.

Availability

Electronic price list updated with release 164.B (U.S.) and 138.B (Canada), dated September 18, 2006.

Price Adjustment

U.S. Price List 164
Canada Price List 138
Effective July 17, 2006

+3% on all prices, options, and surface materials within Steelcase Specification Guides effective July 17, 2006.
The Canadian pricing factor is 1.2 for Price List 138.

Please refer to the current Electronic Price List (ECAT) for actual pricing information.

Prices in this specification guide have not been updated with price List 164 unless noted.

► For a list of all trademarks, refer to the last page of this specification guide.



For 137 Canadian Pricing

Calculate in the following order to avoid rounding errors:

- Multiply the **162** base price and each option by 1.25.
- Round each to the nearest dollar.
- Add base and options for total list price.

► See **164** U.S./**138** Canada price adjustment information above.

Statement of Line	2
Work Being Performed	8
Basics of Ergonomic Seating	9
Basics of Adjustability	10
Additional Resources	12

Product Information

Work Chairs

Leap 462 Series	13
Leap 464 Series WorkLounge	33
Siento 499 Series	43
Criterion 453 Series	51
Think 465 Series	69
Drive 461 Series	95
Jersey Series	105
Sensor 458 Series	121
Rally 457 Series	137
Protegé 433 Series	147
Cachet 487 Series	159

Multi-Use Chairs

Ally 463 Series	175
Player 475 Series	181
Move 490 Series	199
Snodgrass 474 Series	209
Jersey Series	216
Sensor 458 Series	216
Rally 457 Series	216
Protegé 433 Series	216
Cachet 487 Series	216

Stackable Chairs

Parade! 470 Series	217
Max-Stacker 472 Series	225
Max-Stacker II 473 Series	235

Transitional Products	245
------------------------------	------------

Surface Materials	247
--------------------------	------------

Resources	259
------------------	------------

Statement of Line

Work Chairs

Leap 462 Series



Work Chairs
Upholstery on Back
and Seat
▶ Page 24



Work Chairs
3D Knit on Back with
Upholstery on Seat
▶ Page 26



Stools
Upholstery on Back
and Seat
▶ Page 28



Stools
3D Knit on Back with
Upholstery on Seat
▶ Page 30

Leap 464 Series WorkLounge



Ribbon Backframe
WorkLounge
▶ Page 40

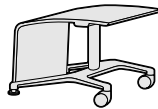

Ottoman
▶ Page 41

Siento



High-Back
Desk Chair with
T-Arms
▶ Page 48



High-Back
Desk Chair with
Enclosed Arms
▶ Page 48



Mid-Back
Desk Chair with
T-Arms
▶ Page 48



Mid-Back
Desk Chair with
Enclosed Arms
▶ Page 48

Criterion 453 Series



High-Back
Work Chairs
▶ Page 58



Mid-Back
Work Chairs
▶ Page 60



High-Back
Stools
▶ Page 62



Mid-Back
Stools
▶ Page 64



Plus High-Back
Work Chairs
▶ Page 66

Work Chairs, continued

Think 465 Series



Work Chairs with 3D Knit Back
▶ Pages 76–81, 86–89



Work Chairs with Headrest and 3D Knit Back
▶ Pages 78–81, 86–89



Work Chairs with Standard or Sewn Upholstery
▶ Pages 82–85, 90–93



Work Chairs with Headrest and Standard or Sewn Upholstery
▶ Pages 82–85, 90–93

Drive 461 Series



Full-Back Work Chairs
▶ Page 102

Jersey Series



Work Chairs
▶ Pages 113–114



Multi-Use Chairs
▶ Pages 115–118

Sensor 458 Series



Size II Adjustable High-Back Work Chairs
▶ Page 128



Size II Adjustable-Back Work Chairs
▶ Page 130



Size II High-Back Work Chairs
▶ Page 132



Size II Mid-Back Work Chairs
▶ Page 134



Size II Mid-Back Sled-Base Multi-Use Chairs
▶ Page 136

Work Chairs, continued

Rally 457 Series



High-Back
Work Chairs
▶ Page 142



Mid-Back
Work Chairs
▶ Page 142



Mid-Back
Multi-Use Chairs
▶ Page 144



Mid-Back
Sled-Base
Multi-Use Chairs
▶ Page 144

Protegé 433 Series



Work Chairs
▶ Page 154



Multi-Use Chairs
▶ Page 156



Sled-Base
Multi-Use Chairs
▶ Page 158

Cachet 487 Series



Swivel-Base
Work Chairs
▶ Page 164



Leg-Base*
Multi-Use Chairs
Without Arms
▶ Page 166



Leg-Base*
Multi-Use Chairs
With Flip-Up Arms
▶ Page 166



Swivel-Base
Stools
▶ Page 168

*Cachet leg-base chair models also stack.

Multi-Use Chairs

Ally 463 Series



Sled-Base
Multi-Use Chair
With Arms
▶ Page 180



Sled-Base
Multi-Use Chair
Without Arms
▶ Page 180

Player 475 Series



Leg-Base*
Multi-Use Chairs
Without Arms
▶ Page 186



Leg-Base*
Multi-Use Chairs
With Arms
▶ Pages 186–189



Leg-Base
Multi-Use Chairs
With Arms and
Casters
▶ Page 186



Sled-Base
Multi-Use Chairs
Without Arms
▶ Page 190



Sled-Base
Multi-Use Chairs
With Arms
▶ Pages 190–193



Stool With Arms
▶ Page 194



Stool
Without Arms
▶ Page 194

*Player leg-base chair models also stack.

Move 490 Series



Multi-Use Chairs
Without Arms
▶ Page 206



Multi-Use Chairs
Without Arms
With Casters
▶ Page 206



Multi-Use Chairs
With Arms
▶ Page 206



Multi-Use Chairs
With Arms and
Casters
▶ Page 206

Snodgrass 474 Series



Multi-Use Chairs
With Open Back
With Arms
▶ Page 214



Multi-Use Chairs
With Open Back
Armless
▶ Page 214



Multi-Use Chairs
With Full Back
With Arms
▶ Page 214



Multi-Use Chairs
With Full Back
Armless
▶ Page 214

Multi-Use Chairs, continued

Jersey Series



Multi-Use Chair
With Arms
▶ Pages 115–116



Multi-Use Chair
Without Arms
▶ Pages 115–116

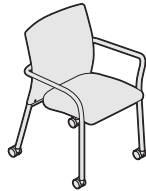

Multi-Use Chair
With Arms and
With Casters
▶ Pages 117–118



Multi-Use Chair
Without Arms and
With Casters
▶ Pages 117–118

Sensor 458 Series



Size II
Mid-Back
Sled-Base
Multi-Use Chairs
▶ Page 136

Rally 457 Series



Mid-Back
Multi-Use Chairs
▶ Page 144



Mid-Back
Sled-Base
Multi-Use Chairs
▶ Page 144

Protegé 433 Series



Multi-Use Chairs
▶ Page 156



Sled-Base
Multi-Use Chairs
▶ Page 158

Cachet 487 Series



Leg-Base*
Multi-Use Chair
Without Arms
▶ Page 166



Leg-Base*
Multi-Use Chair
With Flip-Up Arms
▶ Page 166

*Cachet leg-base chair models also stack.

Stackable Chairs

Parade! 470 Series



Stackable Chairs
▶ Page 222

Max-Stacker 472 Series



Stackable Chairs
▶ Page 230

Max-Stacker II 473 Series



Stackable Chairs
▶ Page 240

Work Being Performed

Work Being Performed... Interaction and Autonomy Seating Matrix

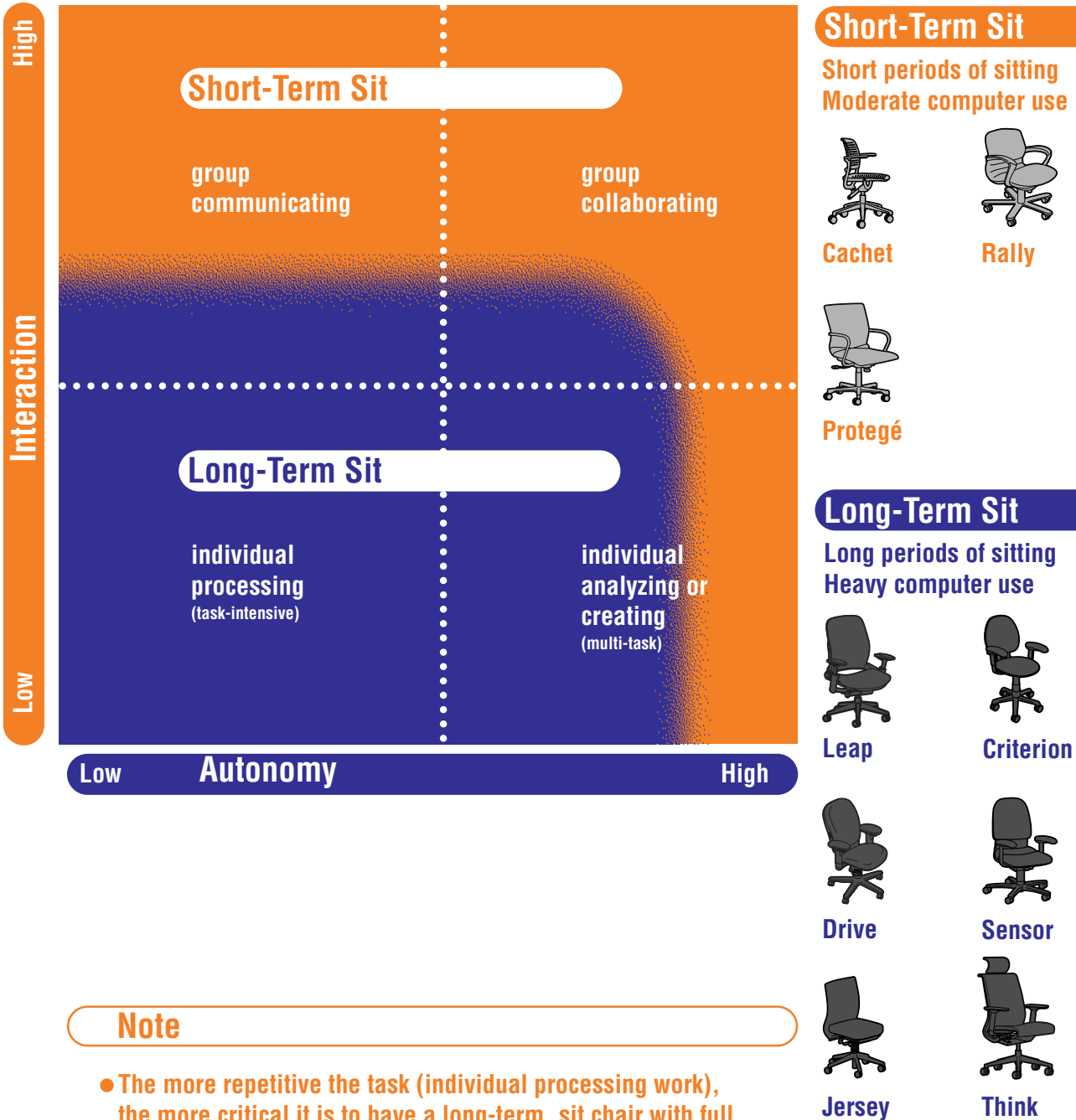

Note

- The more repetitive the task (individual processing work), the more critical it is to have a long-term, sit chair with full adjustability.
- In some cases, a short-term, sit chair can be used for short-term, individual analyzing or creating.

Basics of Ergonomic Seating

Proper ergonomic seating can help workers perform more efficiently and avoid muscle and eye strain.

Neck is straight or slightly forward.

Shoulders are relaxed so arms hang naturally.

Back has full contact with the backrest (sit all the way back in your chair).

Elbows and forearms can rest comfortably on the arms of your chair, or on worksurfaces that are used for writing, paperwork, and other tasks.

Lower back fits into curved lumbar support.

Tension is adjusted so backrest tilts easily, yet provides smooth, even support.

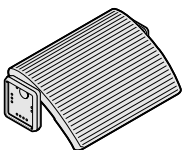

If worksurfaces and keyboard support are not height-adjustable, raise your chair's seat height to achieve the appropriate relationship to your tasks. If this leaves your feet dangling above the floor, use a Details footrest.

Call Details, 1.800.833.0411, or your Steelcase dealer, for additional information or price list.

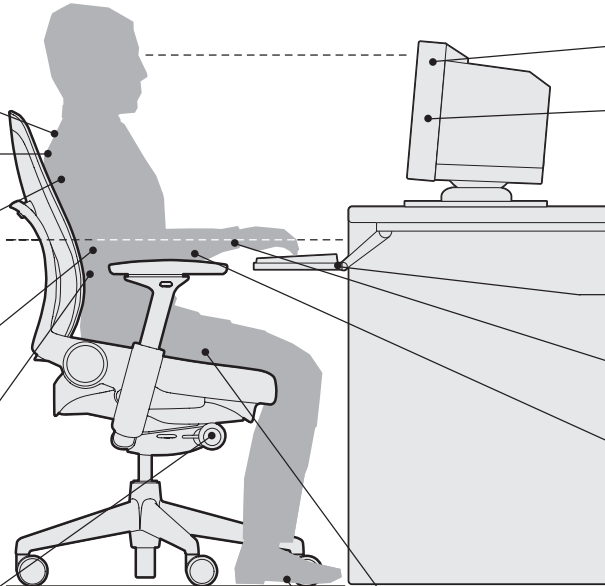

Top of monitor should be at eye level.

Screen is 20 to 30 inches from the eyes.

Screen is at eye level slightly lower and directly in front of worker so head is not turned.

Keyboard is at elbow height.

Wrists should be straight when keying or mousing, not bent up or down.

When keying or mousing, forearms are parallel to the floor.

Thighs are parallel to the floor.

Feet are flat on the floor or on a footrest.

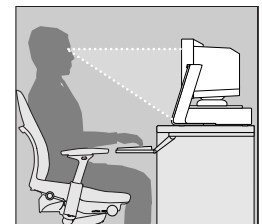

Keep frequently viewed objects, such as a VDT or source document, at or below the horizontal line of sight. Arrange display screen and documents to be equidistant from your eyes.

ANSI/BIFMA is the American National Standards Institute/Business and Institutional Furniture Manufacturer's Association. All Steelcase furniture meets or exceeds ANSI/BIFMA standards for structural quality. The following work chairs are tested and warranted for users 300 pounds and under: Leap, Criterion, Think, Drive, Jersey, Rally, Protege, and Cachet. Multi-use chairs tested and warranted for users 300 pounds and under are: Player, Jersey, and Cachet. All Steelcase Seating products also follow the ergonomic guidelines established in BIFMA G1-2002.

Basics of Adjustability

Steelcase chairs offer varying levels of adjustability to meet the needs of many types of users. Adjustable chairs may offer one or more of these features:

Mechanisms



Natural-glide feature causes the seat to slide forward as the user reclines, keeping the user within his or her vision and reach zone (462, 464).



Advanced swivel-tilt feature incorporates a no front-rise design that allows the seat to remain level even when the user leans back (453, 457, 433).



Synchro-tilt feature means the chair back and seat are synchronized to move in a 2:1 ratio. When the user leans back, the seat rises only half as much, allowing the user's feet to remain flat on the floor (499, 461, 458, Jersey).



Your Power weight-activated feature allows for an amount of recline resistance that is directly proportional to the user's weight. The natural-glide feature keeps the user within vision and reach zone (465).



Balanced Action Rocker (BAR) mechanism allows users to recline as the seat flexes. BAR relies on physics to let any user, regardless of posture, height, or weight, find the most comfortable position (487).

Seat Adjustments



Pneumatic height adjustment allows the user to remain seated while adjusting the seat height by way of a control button or lever (all work chairs).



Passive seat edge angle allows front edge of seat to drop down while seat angle remains unchanged (462, 499, 465).



Seat angle adjustment allows the user to change the angle of the seat to a forward position (453, 461, Jersey).



Seat depth adjustment allows the user to slide the seat forward or back (462, 453, 461, 465, Jersey).

Back Adjustments



Lumbar height affords additional lower back support. Grasp lumbar handles and slide up or down to adjust (462, 453, 461, 465).



Lower back firmness changes the amount of firmness user feels in lower back (462, 464).



Upper back tension feature provides an increasing amount of force that increases as the user reclines (462, 464).



Back tension adjustment allows the user to control the amount of resistance felt when leaning back in the chair (all chairs except 462, 465, 487).



Your Preference back control includes four settings—weight-activated, boosted, mid-stop, and upright—that allow for personal preference and work styles (465).



Headrest adjustment allows the user to support head and neck in upright or reclined posture (464, 465).



Variable back stop allows the user to lock the back upright or to preset the range of recline (462, 453, 458, 464).



Upright back lock allows the user to lock the backrest in a full upright position or release it for full recline (499, 461, 457, 433, Jersey).



Back height adjustment allows the user to raise or lower the chair back (453, 458).

Arm Adjustments



Arm height adjustment allows the user to move the arms up or down independently (462, 453, 461, 458, 465, Jersey).



Arm width adjustment allows the user to move the arms in or out independently (462, 453, 461, 458, 465, Jersey).



Arm pivot adjustments allows the user to position arm rests as appropriate for the task being performed (462, 453, 461, 465, Jersey).



Arm depth adjustment allows users to get closer to their work by chair arms moving out of the way (462, 465).

Other Features



Foot ring height can be adjusted up or down for user comfort. Cannot be done from seated position (462, 453, 487).

Work Chair Adjustability Features For Long-Term Sitting

	Leap 462 Series ▶ Page 13	Leap 464 Series WorkLounge ▶ Page 33	Siento 499 Series ▶ Page 43	Criterion 453 Series ▶ Page 51	Criterion Plus 453 Series ▶ Page 51	Think 465 Series ▶ Page 69	Drive 461 Series ▶ Page 95	Jersey Series ▶ Page 105	Sensor 458 Series ▶ Page 121
Mechanisms									
Natural glide	•	•							
Your Power						•			
Advanced swivel-tilt				•	•				
Synchro-tilt			•				•	•	•
Seat Adjustments									
Pneumatic height	•	•	•	•	•	•	•	•	•
Passive seat edge angle	•		•			•			
Seat angle				•	•		•	•	
Seat depth	•			•	•*	•	•	•	
Back Adjustments									
Lumbar height	•			•	•	•	•		•
Lower back firmness	•	•							
Upper back tension	•	•							
Back tension			•	•	•	•	•	•	•
Variable back stop	•	•		•		•			•
Upright back lock			•		•		•	•	•
Back height				•	•				•
Arm Adjustments									
Arm height	•			•	•	•	•	•	•
Arm width	•			•	•	•	•	•	•
Arm pivot	•			•		•	•	•	
Arm depth	•					•			
Other Features									
Foot ring height (stool)	•			•					
Headrest		•	•*			•			

*See product understanding pages for additional details.

Work Chair Adjustability Features For Short-Term Sitting

	Rally 457 Series ▶ Page 137	Protegé 433 Series ▶ Page 147	Cachet 487 Series ▶ Page 159
Mechanisms			
Advanced swivel-tilt	•	•	
Balanced Action Rocker (BAR)			•
Seat Adjustments			
Pneumatic height	•	•	•
Back Adjustments			
Back tension	•	•	
Upright back lock	•	•	
Self adjusting			•

Additional Resources

Steelcase seating is supported with an array of informational materials, tools, and software to help you plan efficiently.

Product brochures and planning tools can be ordered through your Steelcase area office by calling 1.800.784.0358 or through the Steelcase Marketing Communications Web site at in2.steelcase.com.

Printed Materials

Seating Overview

This full-color overview divides chairs into three categories—work chairs, multi-use chairs, and lounge. The overview brochure includes a four-page foldout that contains a visual index and shows customers the array of Steelcase Inc. seating lines. *Form number 06-0000890*

Surface Materials Reference Manual

This publication provides:

- An explanation of the surface materials and their categories
- “Available on” matrices
- Vertical surface fabric and seating upholstery selection listing
- Technical data for surface materials
- Surface material care and cleaning instructions

Planning Tools

Quick Delivery Handbook

This handbook describes all Steelcase, Turnstone, Details, and Steelcase Design Partnership products that are available for 3-Day (3-day shipment), Express12 (12-day delivery), or 15-Day (15-day shipment).

Computer Tools



Product Info

Electronic versions of this and many other specification guides in Acrobat PDF (Portable Document Format) allow you to scan, search, and print any page on virtually any computer. You can access these files at the Steelcase.com Web site or My Sales Online at in2.Steelcase.com.

Electronic Catalog

Accurate sales quotations and purchase orders for Steelcase products are created with specification software that uses Steelcase Electronic Catalog data. Use the data to specify and price style numbers and options for every Steelcase product. The data is updated bimonthly by Steelcase and provided to software programs like the Hedberg Business System, 20-20 CAP Studio, and 20-20 Office Sales.

Furniture Symbol Graphic Data

Steelcase creates 2D and 3D furniture symbols (with attributes) for planning and initially specifying Steelcase products. This data is incorporated into several add-on software packages that work in either a Microstation or an AutoCAD drafting environment.

More Information

For more information about these and other software tools to help you plan effective work environments, email fsl@steelcase.com

Seating Product Training

Basic training for Steelcase seating products is available as part of the Building Product Muscle (BPM) curriculum on the Steelcase University Web site at in2.steelcase.com.

The course and accompanying tool, called “isit”, provide an overview of the most popular Steelcase Inc. seating products, their positioning, statement of line, features and advantages, key competitors, pricing, application, spec tips, and photos. It also covers the basics of the consultative approach to selling seating and provides printable job aids for ongoing performance support.

Support

Steelcase Capabilities

Steelcase products are distributed, installed, and serviced through a network of more than 600 dealers worldwide. Steelcase is also represented with offices and corporate showrooms in 26 U.S. cities, 4 Canadian cities, and in France, Germany, Great Britain, and Japan. Every Steelcase product meets our exceptionally high standards of quality and durability and comes with the Steelcase assurance of excellence in service.

For assistance,

please call your local dealer, the Steelcase Solutions Resource Team, or the Steelcase Solutions Fulfillment Team at 1.888.STEELCASE (1.888.783.3522).

Call the Steelcase Solutions Resource Team prior to placing an order, when working on a bid, or when you need information about product applications and specifications.

Call the Steelcase Solutions Fulfillment Team if you have submitted an order to Steelcase and you need to speak to your Solutions Fulfillment Team Representative about the order. Also call if you have any post-shipment quality or warranty concerns or service parts questions.

Outside the U.S.A., Canada, Mexico, Puerto Rico, and the U.S. Virgin Islands, call 1.616.247.2500.

For information about Steelcase, the name of your nearest Steelcase dealer, or for product literature, call 1.800.333.9939 or visit our Web site: www.steelcase.com.

Understanding and Specifying Leap 462 Series Work Chairs

Understanding Leap 462 Series

Details	14
Leap Upholstery	18
Dimensions	20

Specifying Leap 462 Series

Value Package

Work Chair	22
------------	----

Work Chairs

Upholstery on Back and Seat	24
3D Knit on Back with Upholstery on Seat	26

Stools

Upholstery on Back and Seat	28
3D Knit on Back with Upholstery on Seat	30

Work Chairs

Highly adjustable task seating offers maximum personalization for people who sit most of the day performing repetitive tasks. By making a series of simple adjustments, you can customize the chair to your body, preferences, and tasks. These chairs provide continuous, stable, task-oriented comfort, and can be quickly adjusted to support you in upright, forward, and reclining work postures.

- Leap 462 Series
- Leap 464 Series WorkLounge
- Siento 499 Series
- Criterion 453 Series
- Think 465 Series
- Drive 461 Series
- Jersey Series
- Sensor 458 Series

Adjustability Features

▶ See page 11 for a comparison to other chairs. **Leap 462 Series**

Mechanisms

Natural glide	●
---------------	---

Seat Adjustments

Pneumatic height	●
------------------	---

Passive seat edge angle	●
-------------------------	---

Seat depth	●
------------	---

Back Adjustments

Lumbar height	●
---------------	---

Lower back firmness	●
---------------------	---

Upper back tension	●
--------------------	---

Variable back stop	●
--------------------	---

Arm Adjustments

Arm height	●
------------	---

Arm width	●
-----------	---

Arm pivot	●
-----------	---

Arm depth	●
-----------	---

Other Features

Foot ring height (stool)	●
--------------------------	---

Leap 462 Series

Leap—a healthier way to sit.

Outer back and outer seat are plastic.

Lumbar height of 5" of additional lower back support is standard on all chairs, but may be omitted.

Arm height can adjust independently within a 4" range to help relieve upper back and shoulder fatigue.

Seat depth adjusts within a 3" range. Seat depth is standard on all models.

Five-arm base is standard.

Casters have hard, dual-wheels that roll smoothly on carpets. They are 2½" for increased mobility. Soft, dual-wheel casters are available for use on hard floors or chair mats. Stools are standard with 2" hard casters. Soft casters are available as an option.

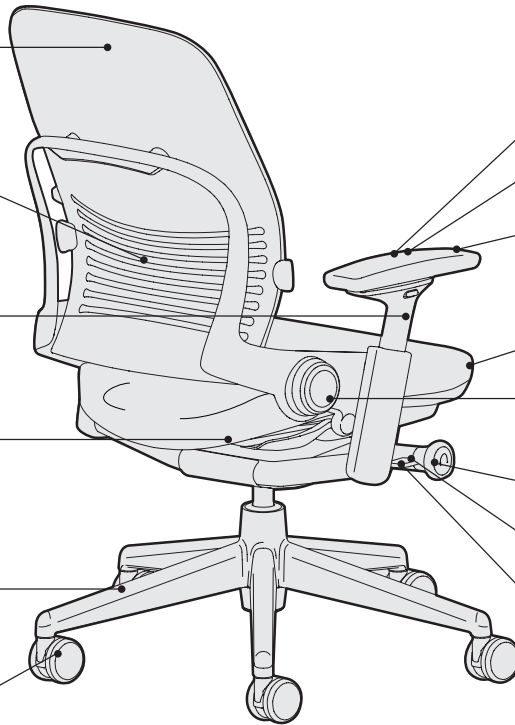

Arm depth can be adjusted approximately 3", enabling individuals to get closer to their work.

Arm width can adjust 4½" overall to provide forearm support.

Arm caps can pivot 30° in and out to accommodate individual user preferences.

Passive seat edge angle allows the front edge of the seat to flex 1½", relieving pressure behind the thighs.

Lower back firmness changes the amount of firmness user feels in lower back. Requires only two complete turns.

Upper back force requires only five complete turns and accommodates a broader range of users by allowing user to change the rate of increase in force as the user reclines.

Seat height adjusts within a 5" range with a pneumatic adjustment mechanism. A 7" range is available as an option. Stools have an 8" range.

Variable back stop with five positions is standard.

Product Details

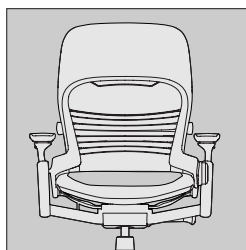

Parallel slats in back shell provide extensive flexibility to allow back to conform to individual users.

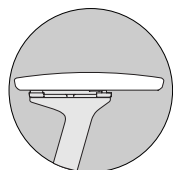

Rectilinear arms with soft caps are standard.

Models are standard with adjustable seats that include seat depth and passive seat edge angle.

Adjustability instructions are included with every chair. Fully adjustable arm models include instructions under the arm cap. Instructions can also be found at steelcase.com

Controls under the seat include tactile braille designators.

Adjustment Features

Seat Adjustments

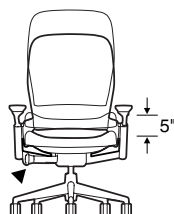

Seat height adjusts pneumatically. To lower, hold handle up while seated. To raise, hold handle up and keep your weight off the chair. Range of adjustability is 5", from 15½"H to 20½"H, and is standard on work chairs. A 7" range of adjustability (16¼"H to 23¼"H) is available as an option. An 8" range of adjustability (22"H to 30"H) is available on stools.



Seat edge flexes, relieving pressure under the user's thighs. The front flexes 1½". This feature is standard on all work chairs and stools.

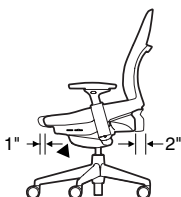

Seat depth adjusts 3" (15¾"-18¾") by pulling handle up. Slide seat forward or back to accommodate various leg lengths. Release handle to lock. This feature is standard on work chairs and stools.

Back Adjustments

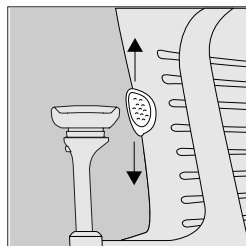

Lumbar height adjusts 5" (5¼" to 10¼" from seat) by grabbing exposed tabs and sliding the lumbar support up or down. This feature is standard on work chairs and stools, but may be omitted.

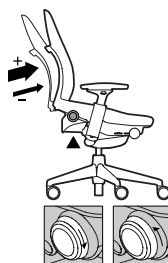

Lower back firmness adjusts by turning knob two complete turns. Forward increases firmness. Backward decreases firmness. This feature is standard on work chairs and stools.



Upper back force adjusts by turning knob five complete turns. Turn knob forward to increase rate of tension; backward to decrease. This feature is standard on work chairs and stools.

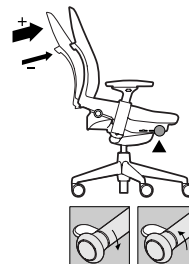

Variable back stop. Rotate handle up or down to set recline angle. Lean back to desired back angle. Five stops are available. This feature is standard on work chairs and stools. *Tip: To stop in upright position, remove weight from back and rotate lever up.*

Arm Adjustments

Rectilinear height-, width-, pivot-, and depth-adjustable arms come standard on all arm models of chairs and stools.

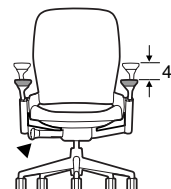

Arm height adjusts independently within a range of 4" (7"-11" from the seat). Push button on outside and under arm cap in while moving arms up or down. Releasing buttons locks arms in position.

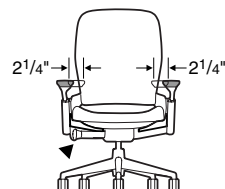

Arm width adjusts 2¼" each independently on chairs with this option. Grasp arm and move in or out.

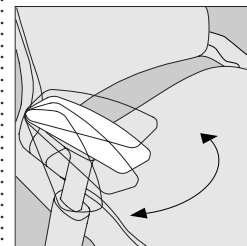

Arms pivot in and out 30° independently on models with adjustable-width arms. Grasp arm and push front to left or right.

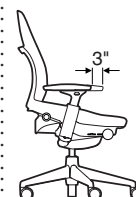

Arm depth adjusts approximately 3" to enable user to get closer to worksurface.

Adjustment Features, continued

Other Features

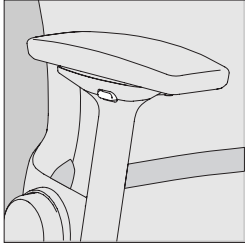

Height-only adjustable arm is also available and adjusts 4"



Armless models are also available.

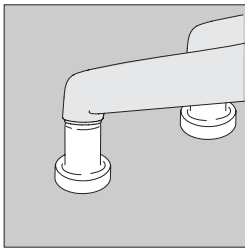

Glides are available as an option. Glides ship with chair or stool for field installation and maintain same height as casters.

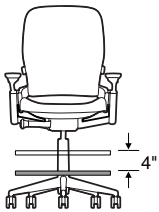

Foot ring height on stools adjusts by first lifting ring and rotating it counter-clockwise to unlock it. Then raise or lower ring up to 4" to desired position before rotating it clockwise to lock it.

Soft-wheel casters for hard floors are available for specific applications.

Surface Materials

► See surface materials on page 248 for specific availability or refer to the *Surface Materials Reference Manual* for further information.

Upholstery

- Fabric
- Fabric with soil-retardant treatment (option)
- 3D Knit (back only)
- Leather
- Vinyl

Hard components

(ribbon back frame, outer back, arm retainer, and base)

- 6205 Black
- 6249 Platinum
- 6259 Midnight

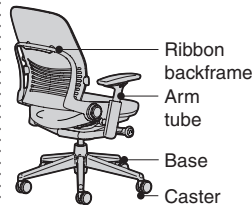

Polished aluminum package is available on black chairs only. Polished aluminum is applied to ribbon back frame, base, and casters. Stools and armless chairs are not available with this package.

Arms

- Black only

Column and foot ring on stools

- 7207 Black only

All Steelcase seating with standard upholstery fabrics complies with requirements of the BIFMA First Generation Voluntary Upholstered Furniture Flammability Standard, as well as the State of California Technical Bulletin 117. All standard seating is labeled to be in compliance with California TB117.

Programs & Services

► See the *Surface Materials Reference Manual* for further detail about programs and services offered for seating.

The Customer's Own Material (COM) Program

offers the opportunity for customers to select fabrics that are not offered through the standard Steelcase surface materials program for use on Steelcase products. Through the COM program, Steelcase will test your materials for application on Steelcase products. Once approved, you can place your order. Steelcase will facilitate the entire ordering process and give you a production schedule. Steelcase will order the COM fabric directly from the textile manufacturer. For up-to-date information regarding fabric test results for all COM fabrics and details regarding yardage requirements for most Seating lines, visit the COM Web site. To locate the COM Web site:

- Visit www.steelcase.com
- Click on "Knowledge & Design"
- Select "Customer's Own Material"

Soil retardants are treatments that provide long-term soil and stain resistance to a fabric without affecting the shade or the integrity of the fabric. The following Steelcase Textiles are available pre-treated with soil retardant. (You do not need to select the soil-retardant option for these fabrics and incur the upcharge.)

- Jacks
- Link
- Regis
- Roulette
- Skittles
- Spyder

Soil-retardant treatment is available on all other seating fabrics at an additional upcharge per seating unit. To order this option, please select "Soil-Retardant Treatment" under "Optional Accessories."

For soil-retardant treatment on COMs, please select "Soil-Retardant Treatment" under "Optional Accessories." Minimums or additional yardage may be required. Please contact the vendor directly for specific information.

Extended lead times may be necessary for this service.

Contact your Steelcase Solutions Fulfillment Team Representative at 1.888.STEELCASE (1.888.783.3522).

Fire Codes

► See pages 254–255 for upholstery fabrics available for use with FCS modification.

Steelcase offers Fire Code Seating modification (FCS) on nearly all seating models. The most rigorous fire codes in the nation have been developed in California, and the Steelcase FCS modification is designed to meet those codes. Fire Code Seating (FCS) indicates that a product is constructed to meet the strict fire code requirements of high public occupancy areas such as theaters, meeting rooms, and lobbies. The FCS standards will meet both the State of California Home Furnishing Technical Bulletin 133 (Cal TB 133) and Boston Fire Code (BFC). Boston adopted the California Home Furnishing Technical Bulletin TB 133 test standard in 1992.

Local codes may have special requirements for upholstery.

Dimensions

- ▶ Page 20

Resources**Printed Materials**

- ▶ Why Leap (S11014)
- ▶ Leap Brochure (05-0002313)
- ▶ Leap Overview Positioning Piece (S11016)
- ▶ Leap White Paper Packets (S11019)
- ▶ Work Effectiveness Study White Papers (02-0001642)
- ▶ Leap Quick Reference Pocket Card (S11042)
- ▶ Leap User Guide (S11236)
- ▶ Seating Overview (06-0000890)
- ▶ Innovation Seating Brochure (04-0011870)

Computer Tools

- ▶ Interactive User Guide available on www.steelcase.com
- ▶ Electronic User Disk (S2305)—Windows
- ▶ Leap CD-ROM (S11015)

Leap Upholstery

What Is It?

Fabric, leather, or vinyl-covered back and seat, 3D knit back.

Fabric

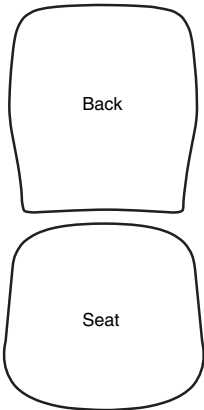

Leather or Vinyl

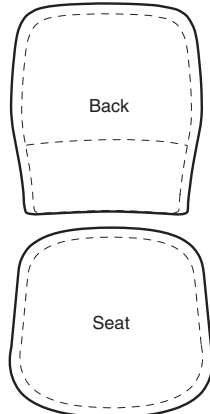

3D Knit Back

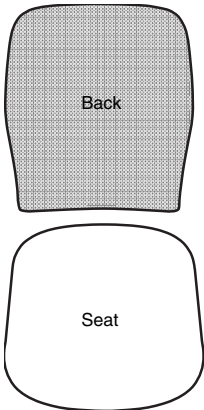

Stitched seams are included on the back cushion and seat cushion of the following:

- Leather
- Customer's Own Leather (COL)
- Vinyl
- Customer's Own Vinyl (COV)
- Select Customer's Own Material (COM)

3D Knit back is available in six colors. 3D Knit back comprises three layers: the 3D Knit, a solid fabric that matches the 3D Knit color, and the polyester cushion that provides exceptional comfort. The seat on these models can be specified to match the 3D Knit color (Vibe) or in any other material.

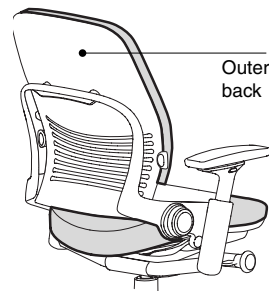
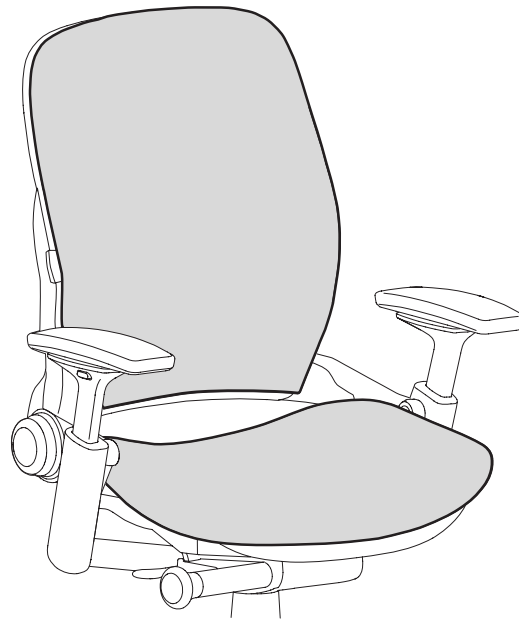

Plastic outer back is fully exposed.

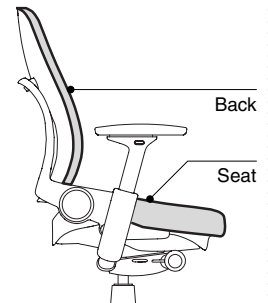

Seat and back cushions can be removed and replaced if damaged.

Dimensions

Leap 462 Series

• Features	• Overall Depth	Width	Height	• Seat Depth	• Functional Seat Depth	• Seat Width	• Seat Height from Floor	• Back Width	• Back Height from Seat
------------	-----------------	-------	--------	--------------	-------------------------	--------------	--------------------------	--------------	-------------------------

Leap 462 Series

Work Chairs

Adjustable Seat Depth	21 ³ / ₄ " to 24 ³ / ₄ "	27"	38 ¹ / ₂ " to 43 ¹ / ₂ "	19"	15 ³ / ₄ " to 18 ³ / ₄ "	19 ¹ / ₄ "	15 ¹ / ₂ " to 20 ¹ / ₂ "*	18"	25"
-----------------------	--	-----	--	-----	--	----------------------------------	---	-----	-----

Stools

Adjustable Seat Depth	21 ³ / ₄ " to 24"	27"	40 ¹ / ₂ " to 48 ¹ / ₂ "	19"	15 ³ / ₄ " to 18 ³ / ₄ "	19 ¹ / ₄ "	22" to 30"	18"	25"
-----------------------	---	-----	--	-----	--	----------------------------------	------------	-----	-----

Dimensions were measured with BIFMA CMD (chair-measuring device).

Arm width adjustment

is 13"–20". Arm pivot adjustment adds 2³/₄" to the width providing a total of 12¹/₄"–21" of width between the arms.

*Seat height from floor

on chairs with Polished Aluminum base is 16".

• Back Lumbar Height	• Lumbar Flex Zone	• Width Between Arms	• Arm to Floor	• Arm Height from Seat	• Arm Cap Pivot Range	• Seat Pan Angle	• Angle Between Seat and Back
Work Chairs							
5 1/4" to 10 1/4"	5 1/4" to 10 1/4"	13" to 20"	22" to 31"	7" to 11"	30°	-1° to 3°	96° to 114°
Stools							
5 1/4" to 10 1/4"	5 1/4" to 10 1/4"	13" to 20"	28" to 40"	7" to 11"	30°	-1° to 3°	96° to 114°

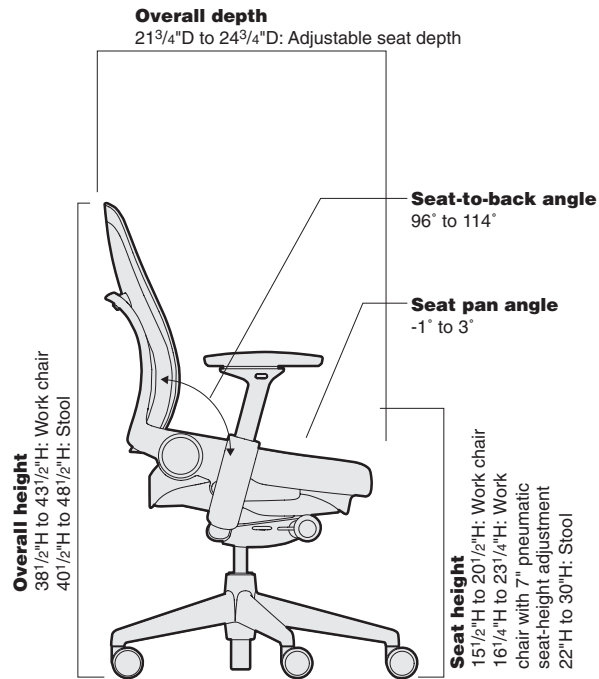
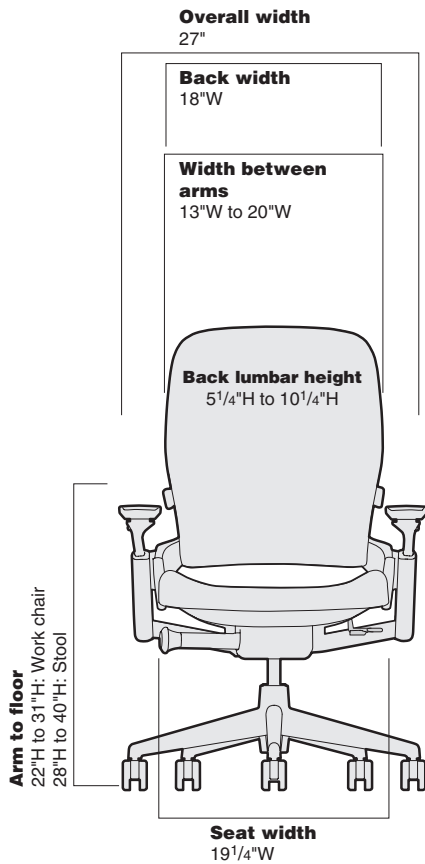

Leap 462 Series Value Package Work Chair



Tip: Leap value package work chair offers Leap chair features at a lower price than when selected individually.

Standard Includes	Required to Specify
<ul style="list-style-type: none"> • Upper back force • 5" pneumatic seat-height adjustment • Variable back stop • Lower back firmness • Rectilinear independent height-, width-, pivot- and depth-adjustable arms: black plastic • Adjustable seat depth 3" • Passive seat edge angle • Adjustable lumbar • Frame, seat shell, outer back, and five-arm base: black plastic only • Standard upholstery design: Buzz2 fabric only • 2½"-diameter, hard-composition, dual-wheel casters: black 	<ul style="list-style-type: none"> 1 Style number 2 Buzz2 fabric color number for upholstery on seat and back ▶ See <i>Surface Materials</i>, page 248.

Specification Information	
• Style Number	• U.S. Price
LEAPV2	\$1139

US For **164** U.S., multiply all **162** U.S. prices by 1.03. Multiply **164** U.S. by 1.2 for **138** Canadian price. ▶ See page 1 for details.

Leap 462 Series Work Chairs

Upholstery on Back and Seat



Standard Includes		Required to Specify
<ul style="list-style-type: none"> ▶ Need help? Product details, page 14 	<ul style="list-style-type: none"> • Upper back force • 5" pneumatic seat-height adjustment • Variable back stop • Lower back firmness • Rectilinear independent height-, width-, pivot-, and depth-adjustable arms and soft arm caps, if selected: black plastic • Frame, seat shell, outer back, and five-arm base: plastic • Adjustable seat depth 3" • Passive seat edge angle • Adjustable lumbar • Standard upholstery design: fabric price group 1 • 2½"-diameter, hard-composition, dual-wheel casters: black 	<ol style="list-style-type: none"> 1 Style number 2 Plastic color for frame, seat shell, outer back, and base 3 Fabric color number for upholstery on seat and back 4 Options, if selected (see below) <p>▶ See <i>Surface Materials</i>, page 248.</p>

	Options	U.S. Price	Required to Specify
Surface Materials	Upholstery		
	• Fabric price group 1	No cost	Specify fabric color number.
	• Fabric price group 2	+\$ 20	Specify fabric color number.
	• Fabric price group 3	+\$ 40	Specify fabric color number.
	• Fabric price group 4	+\$ 55	Specify fabric color number.
	• Fabric price group 5	+\$ 70	Specify fabric color number.
	• Fabric price group 6	+\$ 85	Specify fabric color number.
	• Fabric price group 7	+\$100	Specify fabric color number.
	• Fabric price group 8	+\$125	Specify fabric color number.
	• Fabric price group 9	+\$155	Specify fabric color number.
• Fabric price group 10	+\$175	Specify fabric color number.	
• Customer's Own Material (COM)	No cost	▶ See <i>Surface Materials Reference Manual</i> to specify.	
	• Steelcase leather upholstery	+\$590	Add suffix S to the style number and specify leather color number.
	• Steelcase vinyl	+\$ 60	Add suffix S to the style number and specify vinyl color number.
	• Customer's Own Leather (COL)	+\$299	Add suffix S to the style number and specify leather color number.
	• Customer's Own Vinyl (COV)	+\$ 60	Add suffix S to the style number and specify vinyl color number.
	• Fire Code Seating (FCS)	+\$ 50	Add suffix F to the style number.
	• Soil-retardant treatment applied to upholstery fabric	+\$ 20	Specify <i>with soil-retardant treatment</i> .
	Polished aluminum package		
	• Polished aluminum package on chairs with arms and 6205 Black frame finish	+\$400	Add suffix C to the style number.
	Platinum		
	• On frame, base, arm retainer, and outer back	+\$ 50	Specify <i>with 6249 Platinum</i> .
Arms	• Height-adjustable arms, soft arm caps	-\$100	Specify <i>with height-adjustable arms</i> .
	• Armless	-\$225	Specify <i>without arms</i> .
Seat Height	• 7" pneumatic seat-height adjustment	+\$ 40	Specify <i>with 7" pneumatic seat-height adjustment</i> .
Lumbar	• Without lumbar	-\$ 50	Specify <i>without lumbar</i> .
Casters	• Soft, dual-wheel casters for use on hard floors	+\$ 18	Specify <i>with soft casters</i> .
Glides	• Glides: plastic	+\$ 18	Specify <i>with glides</i> .

Tip: Always add suffixes in alphabetical order when specifying options to Leap seating.

Tip: Fire Code Seating (FCS) option is available with certain upholstery fabric choices only.

▶ Pages 254–255

▶ Detailed dimensions, page 20

US 

For **164** U.S., multiply all **162** U.S. prices by 1.03.
 Multiply **164** U.S. by 1.2 for **138** Canadian price.
 ▶ See page 1 for details.

Specification Information



• Style Number	• U.S. Base Price
46216179	\$1199

Leap 462 Series

US 
 For **164** U.S., multiply all
162 U.S. prices by 1.03.
 Multiply **164** U.S. by 1.2 for
138 Canadian price.
 ▶ See page 1 for details.

Leap 462 Series Work Chairs

3D Knit on Back with Upholstery on Seat



	Standard Includes	Required to Specify
<p>► Need help? Product details, page 14</p>	<ul style="list-style-type: none"> • Upper back force • 5" pneumatic seat-height adjustment • Variable back stop • Lower back firmness • Rectilinear independent height-, width-, pivot-, and depth-adjustable arms and soft arm caps, if selected: black plastic • Frame, seat shell, outer back, and five-arm base: plastic • Adjustable seat depth 3" • Passive seat edge angle • Adjustable lumbar • 3D Knit on back only • Standard upholstery design on seat: Fabric price group 1 • 2½"-diameter, hard-composition, dual-wheel casters: black 	<ol style="list-style-type: none"> 1 Style number 2 Plastic color for frame, seat shell, outer back, and base 3 3D Knit color for back 4 Fabric color number for upholstery on seat 5 Options, if selected (see below) <ul style="list-style-type: none"> ► See <i>Surface Materials</i>, page 248.

	Options	U.S. Price	Required to Specify
Surface Materials	Upholstery		
	• Fabric price group 1	No cost	Specify fabric color number.
	• Fabric price group 2	+\$ 10	Specify fabric color number.
	• Fabric price group 3	+\$ 20	Specify fabric color number.
	• Fabric price group 4	+\$ 28	Specify fabric color number.
	• Fabric price group 5	+\$ 35	Specify fabric color number.
	• Fabric price group 6	+\$ 43	Specify fabric color number.
	• Fabric price group 7	+\$ 50	Specify fabric color number.
	• Fabric price group 8	+\$ 65	Specify fabric color number.
	• Fabric price group 9	+\$ 78	Specify fabric color number.
	• Fabric price group 10	+\$ 88	Specify fabric color number.
	• Customer's Own Material (COM)	No cost	► See <i>Surface Materials Reference Manual</i> to specify.
	• Steelcase leather upholstery	+\$300	Add suffix S to the style number and specify leather color number.
• Steelcase vinyl	+\$ 30	Add suffix S to the style number and specify vinyl color number.	
• Customer's Own Leather (COL)	+\$155	Add suffix S to the style number and specify leather color number.	
• Customer's Own Vinyl (COV)	+\$ 30	Add suffix S to the style number and specify vinyl color number.	
• Fire Code Seating (FCS)	+\$ 50	Add suffix F to the style number.	
• Soil-retardant treatment applied to upholstery fabric	+\$ 20	Specify <i>with soil-retardant treatment</i> .	
	Polished aluminum package		
	• Polished aluminum package on chairs with arms and 6205 Black frame finish	+\$400	Add suffix C to the style number.
	Platinum		
	• On frame, base, arm retainer, and outer back	+\$ 50	Specify <i>with 6249 Platinum</i> .
Arms	• Height-adjustable arms, soft arm caps	-\$100	Specify <i>with height-adjustable arms</i> .
	• Armless	-\$225	Specify <i>without arms</i> .
Seat Height	• 7" pneumatic seat-height adjustment	+\$ 40	Specify <i>with 7" pneumatic seat-height adjustment</i> .
Lumbar	• Without lumbar	-\$ 50	Specify <i>without lumbar</i> .
Casters	• Soft, dual-wheel casters for use on hard floors	+\$ 18	Specify <i>with soft casters</i> .
Glides	• Glides: plastic	+\$ 18	Specify <i>with glides</i> .

Tip: Always add suffixes in alphabetical order when specifying options to Leap seating.

Tip: Fire Code Seating (FCS) option is available with certain upholstery fabric choices only.
► Pages 254–255

► Detailed dimensions, page 20

US 

For **164** U.S., multiply all **162** U.S. prices by 1.03.
Multiply **164** U.S. by 1.2 for **138** Canadian price.
► See page 1 for details.

Specification Information



•Style Number	•U.S. Base Price
46216189	\$1239

Leap 462 Series

US 
 For **164** U.S., multiply all
162 U.S. prices by 1.03.
 Multiply **164** U.S. by 1.2 for
138 Canadian price.
 ▶ See page 1 for details.

Leap 462 Series Stool

Upholstery on Back and Seat



▶ Need help?
Product details,
page 14

Standard Includes

- Upper back force
- 8" pneumatic seat-height adjustment
- Variable back stop
- Lower back firmness
- Passive seat edge angle
- Rectilinear independent height-, width-, pivot-, and depth-adjustable arms and soft arm caps, if selected:
black plastic
- Frame, seat shell, outer back, and five-arm base:
plastic
- 3" seat depth adjustment
- Column and 4" adjustable foot ring: black
- Standard upholstery design: fabric price group 1
- 2"-diameter, hard-composition, dual-wheel casters: black

Required to Specify

- 1 Style number
 - 2 Plastic color for frame, seat shell, outer back, and base
 - 3 Fabric color number for upholstery on seat and back
 - 4 Options, if selected (see below)
- ▶ See *Surface Materials*, page 248.

Tip: Always add suffixes in alphabetical order when specifying options to Leap seating.

Tip: Fire Code Seating (FCS) option is available with certain upholstery fabric choices only.

▶ Pages 254–255

	Options	U.S. Price	Required to Specify
Surface Materials	Upholstery		
	• Fabric price group 1	No cost	Specify fabric color number.
	• Fabric price group 2	+\$ 20	Specify fabric color number.
	• Fabric price group 3	+\$ 40	Specify fabric color number.
	• Fabric price group 4	+\$ 55	Specify fabric color number.
	• Fabric price group 5	+\$ 70	Specify fabric color number.
	• Fabric price group 6	+\$ 85	Specify fabric color number.
	• Fabric price group 7	+\$100	Specify fabric color number.
	• Fabric price group 8	+\$125	Specify fabric color number.
	• Fabric price group 9	+\$155	Specify fabric color number.
• Fabric price group 10	+\$175	Specify fabric color number.	
• Customer's Own Material (COM)	No cost	▶ See <i>Surface Materials Reference Manual</i> to specify.	
• Steelcase leather upholstery	+\$590	Add suffix S to the style number and specify leather color number.	
• Steelcase vinyl	+\$ 60	Add suffix S to the style number and specify vinyl color number.	
• Customer's Own Leather (COL)	+\$299	Add suffix S to the style number and specify leather color number.	
• Customer's Own Vinyl (COV)	+\$ 60	Add suffix S to the style number and specify vinyl color number.	
• Fire Code Seating (FCS)	+\$ 50	Add suffix F to the style number.	
• Soil-retardant treatment applied to upholstery fabric	+\$ 20	Specify <i>with soil-retardant treatment</i> .	
	Platinum		
	• On frame, base, arm retainer, and outer back	+\$ 50	Specify <i>with 6249 Platinum</i> .
Arms	• Height-adjustable arms, soft arm caps	-\$100	Specify <i>with height-adjustable arms</i> .
	• Armless	-\$225	Specify <i>without arms</i> .
Lumbar	• Without lumbar	-\$ 50	Specify <i>without lumbar</i> .
Casters	• Soft, dual-wheel casters for use on hard floors	+\$ 18	Specify <i>with soft casters</i> .
Glides	• Glides: plastic	+\$ 18	Specify <i>with glides</i> .

US 

For **164** U.S., multiply all **162** U.S. prices by 1.03.
Multiply **164** U.S. by 1.2 for **138** Canadian price.

▶ See page 1 for details.

Specification Information



•Style •Number	•U.S. •Base •Price
46267179	\$1386

Leap 462 Series

US 
 For **164** U.S., multiply all
162 U.S. prices by 1.03.
 Multiply **164** U.S. by 1.2 for
138 Canadian price.
 ▶ See page 1 for details.

Leap 462 Series Stool

3D Knit on Back with Upholstery on Seat



	Standard Includes	Required to Specify
<p>► Need help? Product details, page 14</p>	<ul style="list-style-type: none"> • Upper back force • 8" pneumatic seat-height adjustment • Variable back stop • Lower back firmness • Passive seat edge angle • Rectilinear independent height-, width-, pivot-, and depth-adjustable arms and soft arm caps, if selected: black plastic • Frame, seat shell, outer back, and five-arm base: plastic • Column and 4" adjustable foot ring: black • 3D Knit on back • 3" seat depth adjustment • Adjustable lumbar • Standard upholstery design on seat: fabric price group 1 • 2"-diameter, hard-composition, dual-wheel casters: black 	<ol style="list-style-type: none"> 1 Style number 2 Plastic color for frame, seat shell, outer back, and base 3 3D Knit color for back 4 Fabric color number for upholstery on seat 5 Options, if selected (see below) ► See <i>Surface Materials</i>, page 248.

	Options	U.S. Price	Required to Specify
Surface Materials	Upholstery		
	• Fabric price group 1	No cost	Specify fabric color number.
	• Fabric price group 2	+\$ 10	Specify fabric color number.
	• Fabric price group 3	+\$ 20	Specify fabric color number.
	• Fabric price group 4	+\$ 28	Specify fabric color number.
	• Fabric price group 5	+\$ 35	Specify fabric color number.
	• Fabric price group 6	+\$ 43	Specify fabric color number.
	• Fabric price group 7	+\$ 50	Specify fabric color number.
	• Fabric price group 8	+\$ 65	Specify fabric color number.
	• Fabric price group 9	+\$ 78	Specify fabric color number.
	• Fabric price group 10	+\$ 88	Specify fabric color number.
	• Customer's Own Material (COM)	No cost	► See <i>Surface Materials Reference Manual</i> to specify.
	• Steelcase leather upholstery	+\$300	Add suffix S to the style number and specify leather color number.
• Steelcase vinyl	+\$ 30	Add suffix S to the style number and specify vinyl color number.	
• Customer's Own Leather (COL)	+\$155	Add suffix S to the style number and specify leather color number.	
• Customer's Own Vinyl (COV)	+\$ 30	Add suffix S to the style number and specify vinyl color number.	
• Fire Code Seating (FCS)	+\$ 50	Add suffix F to the style number.	
• Soil-retardant treatment applied to upholstery fabric	+\$ 20	Specify <i>with soil-retardant treatment</i> .	
	Platinum		
	• On frame, base, arm retainer, and outer back	+\$ 50	Specify <i>with 6249 Platinum</i> .
Arms	• Height-adjustable arms, soft arm caps	-\$100	Specify <i>with height-adjustable arms</i> .
	• Armless	-\$225	Specify <i>without arms</i> .
Lumbar	• Without lumbar	-\$ 50	Specify <i>without lumbar</i> .
Casters	• Soft, dual-wheel casters for use on hard floors	+\$ 18	Specify <i>with soft casters</i> .
Glides	• Glides: plastic	+\$ 18	Specify <i>with glides</i> .

Tip: Always add suffixes in alphabetical order when specifying options to Leap seating.

Tip: Fire Code Seating (FCS) option is available with certain upholstery fabric choices only.
► Pages 254–255

► Detailed dimensions, page 20

US 

For **164** U.S., multiply all **162** U.S. prices by 1.03.
Multiply **164** U.S. by 1.2 for **138** Canadian price.
► See page 1 for details.

Specification Information



•Style •Number	•U.S. •Base •Price
46267189	\$1426

Leap 462 Series

US 
 For **164** U.S., multiply all
162 U.S. prices by 1.03.
 Multiply **164** U.S. by 1.2 for
138 Canadian price.
 ▶ See page 1 for details.



Understanding and Specifying Leap 464 Series WorkLounge Work Chairs

Understanding Leap 464 Series WorkLounge

Details	34
Dimensions	38

Specifying Leap 464 Series WorkLounge

WorkLounge and Ottoman	40
------------------------	----

Work Chairs

Highly adjustable task seating offers maximum personalization for people who sit most of the day performing repetitive tasks. By making a series of simple adjustments, you can customize the chair to your body, preferences, and tasks. These chairs provide continuous, stable, task-oriented comfort, and can be quickly adjusted to support you in upright, forward, and reclining work postures.

- Leap 462 Series
- Leap 464 Series WorkLounge
- Siento 499 Series
- Criterion 453 Series
- Think 465 Series
- Drive 461 Series
- Jersey Series
- Sensor 458 Series

Adjustability Features

► See page 11 for a comparison to other chairs.

Leap 464 Series

Mechanisms

Natural glide	●
---------------	---

Seat Adjustments

Pneumatic height	●
------------------	---

Back Adjustments

Lower back firmness	●
---------------------	---

Upper back tension	●
--------------------	---

Variable back stop	●
--------------------	---

Headrest with flip-up pillow	●
------------------------------	---

Leap 464 Series WorkLounge

WorkLounge—a chair designed especially for people who like to work in a deep, reclined posture.

Headrest and flip-up pillow provide neck and head support.

Live back moves with the shape of the user's spine as sitting positions change.

Fixed arms have extra padding to provide forearm support and comfort.

Outer back is fully upholstered.

Ribbon backframe is standard.

Lower back firmness changes the amount of firmness user feels in lower back. Requires only two complete turns.

Lumbar pillow provides extra comfort and support to the lumbar region.

Extra thick seat cushion provides extra comfort.

Upper back force requires only five complete turns and accommodates a broader range of users by allowing user to change the rate of increase in force as the user reclines.

Five-arm base is standard with glides. 3" hard or soft casters are available as options.

Variable back stop with five positions is standard.

Polished aluminum is standard on ribbon backframe, arm supports, base, and casters.

Seat height adjusts within a 3" range with a pneumatic adjustment mechanism.

Ottoman quickly and easily converts from a footrest to an auxiliary work table.

Footrest is cushioned and upholstered. Footrest surface is 15"H from the floor.

Work table, with top up, is 25"H from the floor.

Polished aluminum is standard on post and four-arm base.

Four-arm base is standard with two glides and two hard, dual-wheel casters.

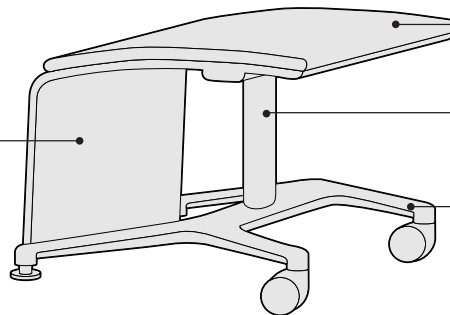
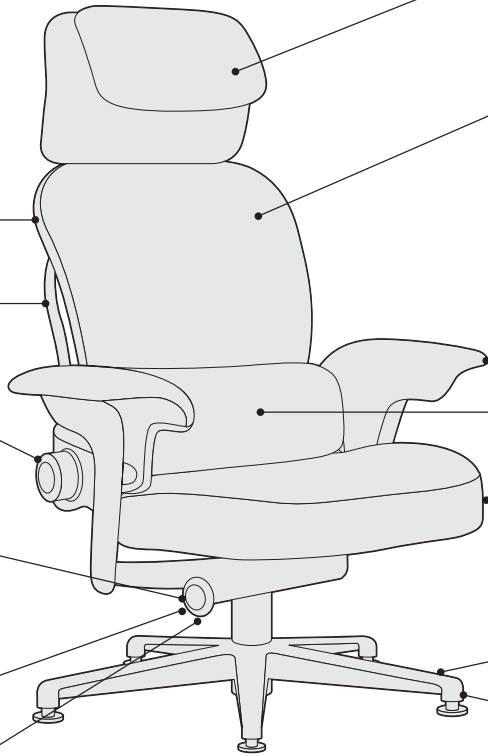

Product Details

Adjustability instructions are included with every chair and ottoman.

Controls under the seat include tactile braille designators.

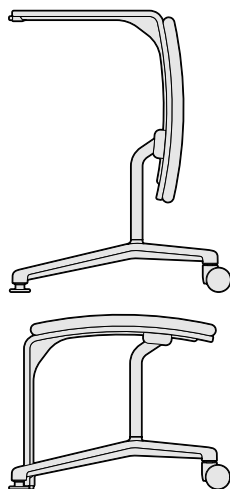

Ottoman easily converts between two positions. With the top up, it is a work table; with the top down it is a footrest. Locking pivot mechanism holds each position in place.

Adjustment Features

Seat Adjustments

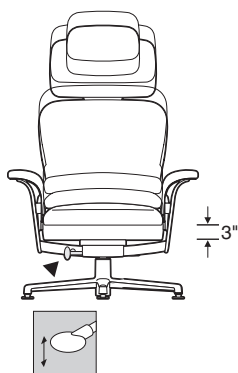

Seat height adjusts pneumatically. To lower, hold handle up while seated. To raise, hold handle up and keep your weight off the chair. This feature is standard. Range of adjustability is 3" from 15"H–18"H with standard glides and 17"H–20"H with optional casters.

Back Adjustments

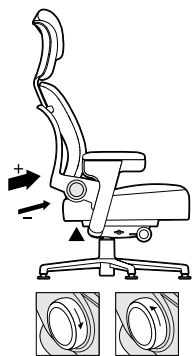

Lower back firmness adjusts by turning knob two complete turns. Forward increases firmness. Backward decreases firmness. This feature is standard.

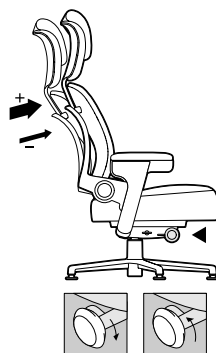

Upper back force adjusts by turning knob five complete turns. Turn knob forward to increase rate of tension; backward to decrease. This feature is standard.

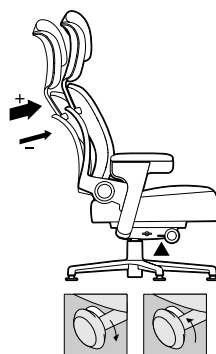

Variable back stop. Rotate handle up or down to set recline angle. Lean back to desired back angle. Five stops are available. This feature is standard.
Tip: To stop in upright position, remove weight from back and rotate lever up.

Other Features

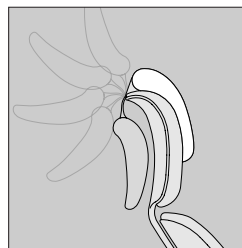

Flip-up pillow can be positioned for use on headrest or placed over the backside of headrest when not in use. This feature is standard.

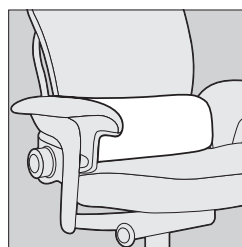

Lumbar pillow is positioned to provide comfort and support to the lumbar region.

Glides are standard.

Casters are optional. 3" polished aluminum hard- or soft-wheel casters are available.

Surface Materials

► See surface materials on page 248 for specific availability or refer to the *Surface Materials Reference Manual* for further information.

Upholstery

- Designtex Wool Suede Too
- Elmo Rustical Leather

Hard components

(Seat shell, glides, and casters)

- 6205 Black

Polished aluminum

is standard on chair and ottoman. Polished aluminum is applied to ribbon backframe, arm supports, base, and casters of chair. Ottoman has polished aluminum on post and base.

Programs & Services

► See the *Surface Materials Reference Manual* for further detail about programs and services offered for seating.

The Customer's Own Material (COM & COL) Program

offers the opportunity for customers to select fabrics and leather that are not offered through the standard Steelcase surface materials program for use on Steelcase products. Avoid pattern fabrics and heavily grained leathers. Through the COM & COL program, Steelcase will test your materials for application on Steelcase products. Once approved, you can place your order. Steelcase will facilitate the entire ordering process and give you a production schedule. Steelcase will order the COM & COL fabric and leather directly from the textile manufacturer. For up-to-date information regarding fabric test results for all COM & COL fabrics and details regarding yardage requirements for most Seating lines, visit the COM Web site. To locate the COM Web site:

- Visit www.steelcase.com
- Click on "Knowledge & Design"
- Select "Customer's Own Material"

Dimensions

- ▶ Page 38

Resources

Printed Materials

- ▶ Leap WorkLounge and Ottoman Brochure (S11526)
- ▶ Leap WorkLounge Hangtag (LP-00052)
- ▶ Leap WorkLounge Ottoman Hangtag (LP-00054)
- ▶ Leap Brochure (05-0002313)
- ▶ Why Leap (S11014)
- ▶ Leap Overview Positioning Piece (S11016)
- ▶ Leap White Paper Packets (S11019)
- ▶ Leap Quick Reference Pocket Card (S11042)
- ▶ Leap User Guide (S11236)
- ▶ Seating Overview (06-0000890)

Computer Tools

- ▶ Electronic User Disk (S2305)—Windows
- ▶ Leap CD-ROM (S11015)
- ▶ www.steelcase.com

Dimensions

Leap 464 Series

	Overall Depth	Width	Height	Seat Depth	Functional Seat Depth	Seat Width	Seat Height from Floor	Back Width	Back Height from Seat
Leap 464 Series									
WorkLounge									
	26 1/2"	31 1/2"	43 1/2" to 46 1/2" with glides 45 1/2" to 48 1/2" with casters	20 1/2"	18 1/2"	19"	14 1/2" to 17 1/2" with glides 16 1/2" to 19 1/2" with casters	20 1/2"	30"
Ottoman									
	19"	18 1/2"	15"	N.A.	N.A.	16 3/4"	15"	N.A.	N.A.

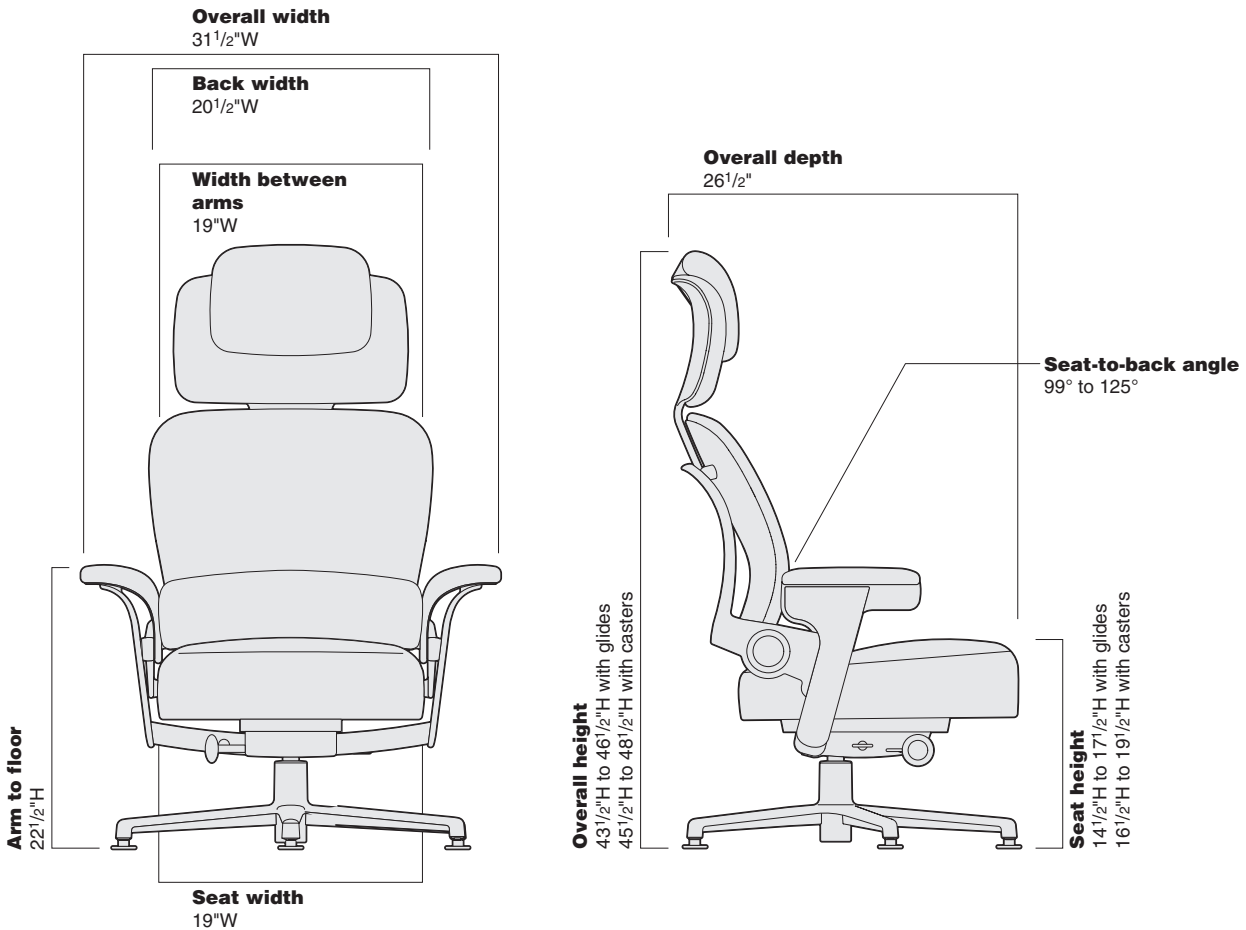

Lumbar Flex Zone	Width Between Arms	Arm to Floor	Arm Height from Seat	Angle Between Seat and Back	Table Height from Floor
WorkLounge					
5¼" to 10¼"	19"	22½"	7¼"	99°–125°	N.A.
Ottoman					
N.A.	N.A.	N.A.	N.A.	N.A.	25"

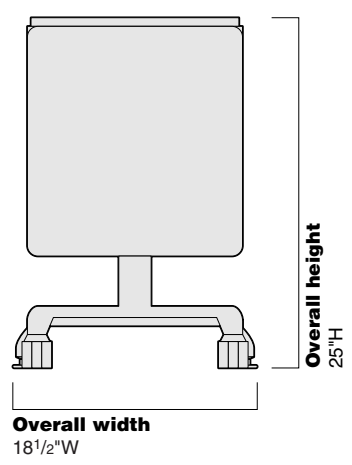
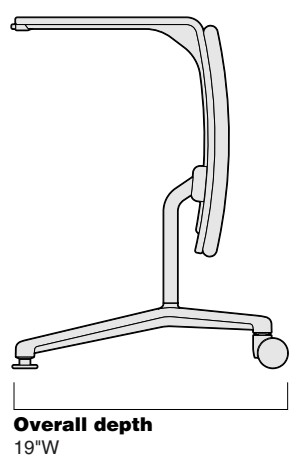
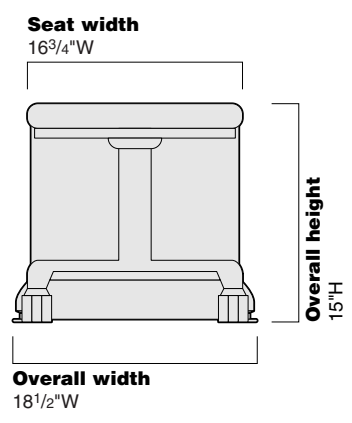
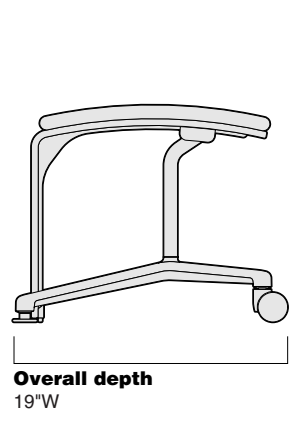

Leap 464 Series WorkLounge and Ottoman

Leap 464 Series WorkLounge

Ribbon Backframe



Standard Includes		Required to Specify
<ul style="list-style-type: none"> ▶ Need help? Product details, page 34 	<ul style="list-style-type: none"> Fully upholstered back, seat, arms, headrest, and flip-up pillow: Designtex Wool Suede Too Upper back force Variable back stop Lower back firmness Lumbar pillow Fixed, non-adjustable arms 3" pneumatic seat-height adjustment Seat and back components: black plastic only Ribbon backframe, arm supports and five-arm base: polished aluminum only Glides: black with stainless steel inserts. 	<ol style="list-style-type: none"> 1 Style number 2 Fabric color number for upholstery on back, seat, arms, headrest, and flip-up pillow 3 Options, if selected (see below) <ul style="list-style-type: none"> ▶ See <i>Surface Materials</i>, page 248.

Options	U.S. Price	Required to Specify
Surface Materials <ul style="list-style-type: none"> Designtex Wool Suede Too Elmo Rustical leather Customer's Own Material (COM) Customer's Own Leather (COL) 	<ul style="list-style-type: none"> No cost +\$550 +\$ 30 +\$ 30 	<ul style="list-style-type: none"> Specify with 59DG and fabric color number. <ul style="list-style-type: none"> ▶ See <i>Surface Materials</i>, page 248. Specify with 59DK and leather color number. <ul style="list-style-type: none"> ▶ See <i>Surface Materials</i>, page 248. ▶ See <i>Surface Materials Reference Manual</i> to specify. ▶ See <i>Surface Materials Reference Manual</i> to specify.
Casters <ul style="list-style-type: none"> 3" hard-composition, dual-wheel casters for use on carpet: polished aluminum and black 3" soft, dual-wheel casters for use on hard floors: polished aluminum and black 	<ul style="list-style-type: none"> +\$ 57 +\$ 57 	<ul style="list-style-type: none"> Specify with hard casters. Specify with soft casters.

Specification Information

Style Number	U.S. Base Price
464LOUNGE	\$2432

▶ Detailed dimensions, page 38



For **164** U.S., multiply all **162** U.S. prices by 1.03. Multiply **164** U.S. by 1.2 for **138** Canadian price. ▶ See page 1 for details.

Leap 464 Series Ottoman



Standard Includes	Required to Specify
<ul style="list-style-type: none"> ▶ Need help? Product details, page 34 • Upholstery on footrest: Designtex Wool Suede Too • Work table and footrest shell: black plastic only • Post and four-arm base: polished aluminum • Two glides: black with stainless steel inserts • Two 2"-diameter, hard-composition, dual-wheel casters: black 	<ul style="list-style-type: none"> 1 Style number 2 Fabric color number for upholstery on footrest 3 Options, if selected (see below) ▶ See <i>Surface Materials</i>, page 248.

Options	U.S. Price	Required to Specify
Surface Materials		
• Designtex Wool Suede Too	No cost	Specify with 59DG and fabric color number.
• Elmo Rustical leather	+\$125	▶ See <i>Surface Materials</i> , page 248. Specify with 59DK and leather color number.
• Customer's Own Material (COM)	+\$ 30	▶ See <i>Surface Materials</i> , page 248.
• Customer's Own Leather (COL)	+\$ 30	▶ See <i>Surface Materials Reference Manual</i> to specify. ▶ See <i>Surface Materials Reference Manual</i> to specify.

Specification Information

Style Number	U.S. Base Price
464OTTOMAN	\$725

Leap 464 Series

▶ Detailed dimensions, page 38

US

For **164** U.S., multiply all **162** U.S. prices by 1.03.
Multiply **164** U.S. by 1.2 for **138** Canadian price.
▶ See page 1 for details.



Understanding and Specifying Siento 499 Series Work Chairs

Understanding Siento 499 Series

Details	44
Dimensions	44

Specifying Siento 499 Series

Design Package High-Back Executive Chair	46
Executive Desk Chairs	48

Work Chairs

Highly adjustable task seating offers maximum personalization for people who sit most of the day performing repetitive tasks. By making a series of simple adjustments, you can customize the chair to your body, preferences, and tasks. These chairs provide continuous, stable, task-oriented comfort, and can be quickly adjusted to support you in upright, forward, and reclining work postures.

- Leap 462 Series
- Leap 464 Series
- Siento 499 Series
- Criterion 453 Series
- Think 465 Series
- Drive 461 Series
- Jersey Series
- Sensor 458 Series

Adjustability Features

▶ See page 11 for a comparison to other chairs.

Siento 499 Series

Mechanisms

Synchro-tilt	●
--------------	---

Seat Adjustments

Pneumatic height	●
------------------	---

Passive seat edge angle	●
-------------------------	---

Back Adjustments

Back tension	●
--------------	---

Upright back lock	●
-------------------	---

Siento

Siento desk chairs, designed by Jorge Pensi, merge remarkable ergonomic comfort in a slim and sophisticated executive form.

Outer back is fully upholstered.

Patented live back technology (found in Steelcase Leap chair) is embedded in the back to change shape and mimic the user's spine.

Arms are available as either T-arms or enclosed.

Five-arm base is available in Polished Aluminum, Platinum, or black.

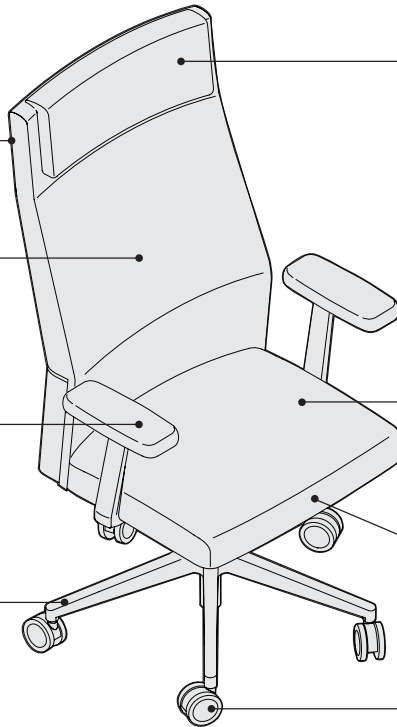

Headrest option provides additional head and neck support.

Seat height adjusts from 16" to 21" and is standard with pneumatic adjustment mechanism. Fixed-height option is also available.

Front seat edge flexes naturally to relieve pressure under the user's thighs.

3" hard dual-wheel casters are provided for use on carpet. Soft dual-wheel casters are available for use on hard floors or chair mats.

Product Details



High-back and mid-back desk chairs are available.



Arms are available as T-arms or enclosed. T-arms are available in urethane or fully upholstered. Enclosed arms are always fully upholstered.

All Siento chairs comply with ANSI/HFS and BIFMA standards.

Actual Dimensions

	High-Back Desk Chairs with Headrest	High-Back Desk Chairs Without Headrest	Mid-Back Desk Chairs
Overall depth	26"	26"	26"
Overall width—outside of T-arms	26¾"	26¾"	26¾"
Overall width—outside of enclosed arms	27½"	27½"	27½"
Overall height	46¾"–51¾"	46"–51"	40"–45"
Seat depth	17"	17"	17"
Seat width	21"	21"	21"
Back height from seat	31½"	30"	24"
Width between arms	20½"	20½"	20½"
Arm height from seat	8"	8"	8"

Adjustability Features

- Pneumatic seat-height
- Upright back lock
- Back tension control
- Synchro-tilt mechanism

Adjustment Features

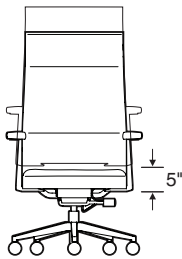

Seat height adjusts pneumatically. To lower, hold handle up while seated. To raise, hold handle up and keep your weight off the chair. Standard range of adjustability is 5" from 16"H to 21"H.



Seat edge flexes, relieving pressure under the user's thighs.

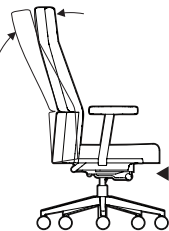

Upright back lock. Flick switch forward to lock; flick switch back to tilt.



Back tension control adjusts by turning knob. Turn knob forward to increase rate of tension, backward to decrease.

Synchro-tilt mechanism provides synchro-tilt back movement while feet remain flat on the floor.

Surface Materials

Upholstery

- Fabric
- Fabric with soil-retardant treatment (option)
- Elmo soft leather

Arms

- Black urethane T-arms
- Upholstered T-arms or enclosed arms

Column

- Black only

Base

- 7207 Black
- 4799 Platinum
- 8046 Polished Aluminum

Casters

- Black wheels with black body on black or Platinum base
- Black wheels with Polished Aluminum body on Polished Aluminum base

All Steelcase seating with standard upholstery fabrics complies with requirements of the BIFMA First Generation Voluntary Upholstered Furniture Standard, as well as State of California Technical Bulletins 116 and 117. All standard seating is labeled to be in compliance with California TB116/117.

Programs & Services

► See the *Surface Materials Reference Manual* for further detail about programs and services offered for seating.

The Customer's Own Material (COM) Program

offers the opportunity for customers to select fabrics that are not offered through the standard Steelcase surface materials program for use on Steelcase products. Through the COM program, Steelcase will test your materials for application on Steelcase products. Once approved, you can place your order. Steelcase will facilitate the entire ordering process and give you a production schedule. Steelcase will order the COM fabric directly from the textile manufacturer. For up-to-date information regarding fabric test results for all COM fabrics and details regarding yardage requirements for most Seating lines, visit the COM Web site. To locate the COM Web site:

- Visit www.steelcase.com
- Click on "Knowledge & Design"
- Select "Customer's Own Material"

Soil retardants are treatments that provide long-term soil and stain resistance to a fabric without affecting the shade or the integrity of the fabric. The following Steelcase Textiles are available pre-treated with soil retardant. (You do not need to select the soil-retardant option for these fabrics and incur the upcharge.)

- Jacks
- Link
- Regis
- Roulette
- Spyder

Soil-retardant treatment is available on all other seating fabrics at an additional upcharge per seating unit. To order this option, please select "Soil-Retardant Treatment" under "Optional Accessories."

For soil-retardant treatment on COMs, please select "Soil-Retardant Treatment" under "Optional Accessories." Minimums or additional yardage may be required. Please contact the vendor directly for specific information.

Extended lead times may be necessary for this service.

Contact your Steelcase Solutions Fulfillment Team Representative at 1.888.STEELCASE (1.888.783.3522).

Local codes may have special requirements for upholstery.

Resources

Siento Brochure
Form number 06-0001282

Siento Design Package High-Back Executive Chair

164 **PRICE ADJUSTMENT: Products reflect 164 pricing, a 3% price increase is not required. The Canadian pricing factor is 1.2 for Price List 138.**



Tip: This design package allows you to obtain the pre-selected features at a lower price than if specifying as a standard model number.

Tip: Options or substitutions are not available on this design package.

Standard Includes	Required to Specify
-------------------	---------------------

- | | | |
|---|---|---|
| <ul style="list-style-type: none"> ▶ Need help? Product details, page 44 | <ul style="list-style-type: none"> • Back tension control • 5" pneumatic seat-height adjustment • Upright back lock • Front seat edge flex • Live back technology • T-arms: upholstered • Headrest • Upholstery: Elmo soft leather • Five-arm base and arm supports: 8046 Polished Aluminum • Column: black only • 3"-diameter, hard composition, dual-wheel casters: black wheels with Polished Aluminum body | <ul style="list-style-type: none"> 1 Style number 2 Elmo soft leather color number ▶ See <i>Surface Materials</i>, page 248. |
|---|---|---|

Specification Information

• Style Number	• U.S. Price
499SIENTO	\$2649

Siento Executive Desk Chairs

164 **PRICE ADJUSTMENT: Products reflect 164 pricing, a 3% price increase is not required. The Canadian pricing factor is 1.2 for Price List 138.**





Tip: When a black or Platinum painted base is specified, the casters will be black. When a Polished Aluminum base is specified, the casters will have black wheels with Polished Aluminum body.

Standard Includes		Required to Specify
<ul style="list-style-type: none"> ▶ Need help? Product details, page 44 	<ul style="list-style-type: none"> • Back tension control • 5" pneumatic seat-height adjustment • Upright back lock • Front seat edge flex • Live back technology • Fully upholstered outer back • T-arms, if selected: soft black urethane • Enclosed arms, if selected: fully upholstered • Upholstery: fabric price group 1 • Five-arm base and arm supports: paint or Polished Aluminum • Column: black only • 3"-diameter, hard-composition, dual-wheel casters: black 	<ol style="list-style-type: none"> 1 Style number 2 Paint color number for base and arm supports 3 Fabric color number for upholstery 4 Options, if selected (see below) <p>▶ See <i>Surface Materials</i>, page 248.</p>

	Options	U.S. Price	Required to Specify
Surface Materials	Upholstery		
	• Fabric price group 1	No cost	Specify fabric color number.
	• Fabric price group 2	+\$ 21	Specify fabric color number.
	• Fabric price group 3	+\$ 41	Specify fabric color number.
	• Fabric price group 4	+\$ 57	Specify fabric color number.
	• Fabric price group 5	+\$ 72	Specify fabric color number.
	• Fabric price group 6	+\$ 88	Specify fabric color number.
	• Fabric price group 7	+\$103	Specify fabric color number.
	• Fabric price group 8	+\$129	Specify fabric color number.
	• Fabric price group 9	+\$160	Specify fabric color number.
• Fabric price group 10	+\$180	Specify fabric color number.	
• Customer's Own Material	+\$ 31	▶ See <i>Surface Materials Reference Manual</i> . Add suffix S to the style number and specify Elmo soft leather color number.	
• Elmo soft leather	+\$700	▶ See <i>Surface Materials</i> , page 248. Specify <i>with soil-retardant treatment</i> .	
	• Soil-retardant treatment applied to upholstery fabric	+\$ 21	
	T-arms		
	• Fully upholstered T-arms	+\$ 75	Specify <i>with fully upholstered T-arms</i> .
	Base and casters		
	• 7207 Black base and black casters	No cost	Specify <i>with 7207 Black base</i> .
	• 4799 Platinum base and black casters	+\$ 50	Specify <i>with 4799 Platinum base</i> .
Seat Height	• 18" fixed seat height	No cost	Specify <i>with fixed seat height</i> .
Headrest	• Headrest on high-back chairs only	+\$100	Specify <i>with headrest</i> .
Casters	• Soft, dual-wheel casters for use on hard floors	+\$ 19	Specify <i>with soft casters</i> .



164 PRICE ADJUSTMENT: Products reflect 164 pricing, a 3% price increase is not required. The Canadian pricing factor is 1.2 for Price List 138.

Specification Information



	T-Arms		Enclosed Upholstered Arms	
				
Description	Style Number	U.S. Base Price	Style Number	U.S. Base Price

High-Back Chairs

	T-Arms		Enclosed Upholstered Arms	
				
Description	Style Number	U.S. Base Price	Style Number	U.S. Base Price
Painted Base	499211	\$1525	499212	\$1725
Polished Aluminum Base	499221	\$1825	499222	\$2025

	T-Arms		Enclosed Upholstered Arms	
				
Description	Style Number	U.S. Base Price	Style Number	U.S. Base Price

Mid-Back Chairs

	T-Arms		Enclosed Upholstered Arms	
				
Description	Style Number	U.S. Base Price	Style Number	U.S. Base Price
Painted Base	499111	\$1425	499112	\$1625
Polished Aluminum Base	499121	\$1725	499122	\$1925

Siento 499 Series



Understanding and Specifying Criterion 453 Series Work Chairs

Understanding Criterion 453 Series

Details	52
Dimensions	56

Specifying Criterion 453 Series

High-Back Work Chairs	58
Mid-Back Work Chairs	60
High-Back Stools	62
Mid-Back Stools	64
Plus High-Back Work Chairs	66

Work Chairs

Highly adjustable task seating offers maximum personalization for people who sit most of the day performing repetitive tasks. By making a series of simple adjustments, you can customize the chair to your body, preferences, and tasks. These chairs provide continuous, stable, task-oriented comfort, and can be quickly adjusted to support you in upright, forward, and reclining work postures.

- Leap 462 Series
- Leap 464 Series WorkLounge
- Siento 499 Series
- Criterion 453 Series
- Think 465 Series
- Drive 461 Series
- Jersey Series
- Sensor 458 Series

Adjustability Features

► See page 11 for a comparison to other chairs.

	Criterion	Criterion Plus
Mechanisms		
Advanced swivel tilt	●	●
Seat Adjustments		
Pneumatic height	●	●
Seat angle	●	●
Seat depth	●	●
Back Adjustments		
Lumbar height	●	●
Back tension	●	●
Variable back stop	●	
Upright back lock		●
Back height	●	●
Arm Adjustments		
Arm height	●	●
Arm width	●	●
Arm pivot	●	
Other Features		
Foot ring height on stool	●	

Criterion 453 Series

Criterion is a high-performance chair, ideal for users who sit for long periods of time. As one of the world's best-selling chairs with a broad range of adjustments, Criterion meets the long-term comfort needs of today's diverse workforce.

Outer back and outer seat is plastic. Fully upholstered outer back is an option.

Arm height adjusts independently within a 4" range to help relieve upper back and shoulder fatigue.

Seat depth adjusts within a 3" range and is available as an option.

Seat height adjusts within a 5" range with a pneumatic adjustment mechanism.

Five-arm base is standard.

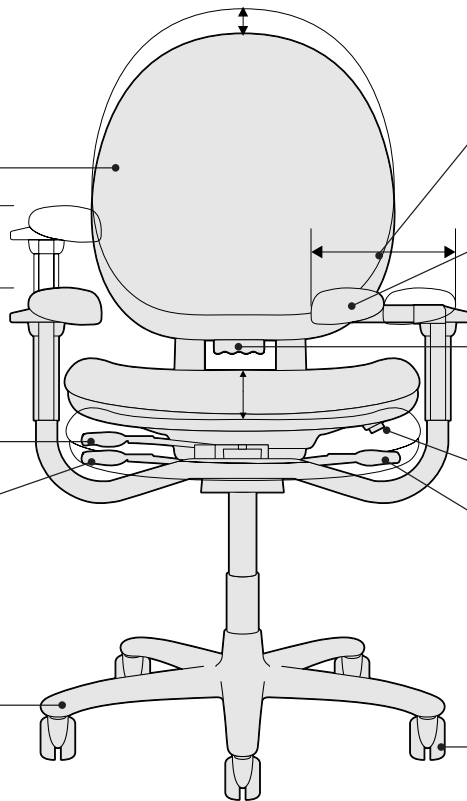

Arm width adjusts within a 4" range for each arm to provide forearm support in neutral position for 5th to 95th percentile office workers.

Arm caps can pivot independently 14° in and 21° out to accommodate individual user preferences.

Back height adjusts up and down within a 2" range to help ensure healthful back posture.

Variable back stop is standard.

Seat angle adjusts forward, upright, and reclined to suit user. Seat angle is standard.

Castors have hard, dual-wheels that roll smoothly on carpets. Soft, dual-wheel casters are available for use on hard floors or chair mats.

Product Details



Three basic sizes are available—high-back, mid-back, and Plus. All are offered with and without arms. High-back and mid-back are also available as stools.

Criterion features a seat angle adjustment which allows the seat angle to function in a fixed or articulating mode. Variable back stop will lock the back in an upright position or allow the user to set a specific back stop position which the chair will recline to.

Criterion Plus has an upright back lock and offers a wider seat with more space between the arms to accommodate workers who need a larger chair. The Criterion Plus chair is tested to hold up to 500 lbs. under normal use.

Upholstery Details

Criterion is standard with a molded upholstered seat and back.



Sewn upholstery can be specified to accommodate vinyl. Seat and back cushions feature a stitched detail.

Adjustment Features

Seat Adjustments

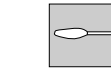
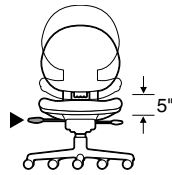

Seat height adjusts pneumatically. To lower, hold handle up while seated. To raise, hold handle up and keep your weight off the chair. Range of adjustability is 5" from 16"H to 21"H.

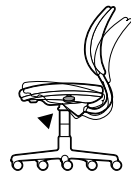

Seat angle adjusts by pulling handle up and shifting your weight to alter seat angle. Release handle to lock. This feature is standard.

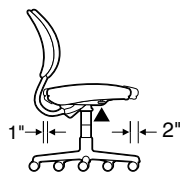

Seat depth adjusts by pulling handle up. Slide seat forward or back to accommodate various leg lengths. Release handle to lock. This feature is optional.

Back Adjustments

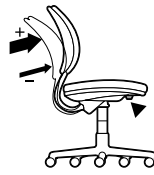

Back tension adjusts by turning knob. Turn knob clockwise to increase tension, counterclockwise to decrease. This feature is standard.

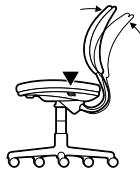

Variable back stop. Hold switch forward to recline. Lean back to desired back angle. Release switch to set tilt range. *Tip: To lock in upright position, remove weight from back and release switch.*

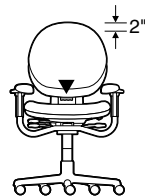

Back height adjusts within a 2" range by pulling handle forward while moving chair back up or down. Release handle to lock chair back in position. This feature is standard.

Arm Adjustments

Arms are available fixed, height-adjustable, height- and width-adjustable, and height-, width-, and pivot-adjustable.

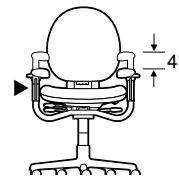

Arm height adjusts independently within a range of 4" on all adjustable arm models. Squeeze triggers in while moving arms up or down. Releasing triggers locks arms in position.

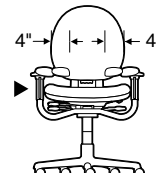

Arm width adjusts independently on chairs with the height- and width-adjustable option. Grasp arm and move in or out. Arm will stay where positioned.

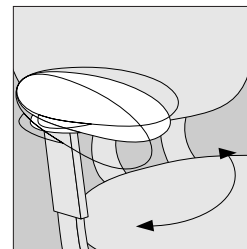

Arms pivot independently on models with height-, width-, and pivot-adjustable arms. Grasp arm and push front to left or right. Pivot adjustment width range is 10 3/4" to 18 1/4".

Other Features

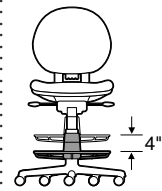

Foot ring height on stools adjusts by first lifting ring and rotating it counterclockwise to unlock it. Then raise or lower ring up to 4" to desired position before rotating it clockwise to lock it.

Alternative casters and glides are available for specific applications, including soft-wheel casters for hard floors.

Glides are 2"H and interchangeable with casters.

Surface Materials

▶ See surface materials on page 248 for specific availability or refer to the *Surface Materials Reference Manual* for further information.

Upholstery

- Fabric
- Fabric with soil-retardant treatment (option)
- Vinyl

Hard components

(base, arms, plastic arm caps, outer back, outer seat, and foot ring)

- Monochromatic color from list of seating plastic color numbers will apply to all hard components.

Outer back and outer seat

- Plastic color to match color of other “hard components”
- Fully upholstered outer back with plastic color outer seat

Arms

- Soft vinyl arm caps to match the plastic color of the other “hard components”
- Upholstered arm caps

Foot ring on stools

- Plastic color to match other “hard components”
- 9201 Polished Chrome

Glides

- Stainless steel only

All Steelcase seating with standard upholstery fabrics

complies with requirements of the BIFMA First Generation Voluntary Upholstered Furniture Flammability Standard, as well as the State of California Technical Bulletin 117. All standard seating is labeled to be in compliance with California TB117.

Programs & Services

▶ See the *Surface Materials Reference Manual* for further detail about programs and services offered for seating.

The Customer's Own Material (COM) Program

offers the opportunity for customers to select fabrics that are not offered through the standard Steelcase surface materials program for use on Steelcase products. Through the COM program, Steelcase will test your materials for application on Steelcase products. Once approved, you can place your order. Steelcase will facilitate the entire ordering process and give you a production schedule. Steelcase will order the COM fabric directly from the textile manufacturer. For up-to-date information regarding fabric test results for all COM fabrics and details regarding yardage requirements for most Seating lines, visit the COM Web site. To locate the COM Web site:

- Visit www.steelcase.com
- Click on “Knowledge & Design”
- Select “Customer's Own Material”

Soil retardants are treatments that provide long-term soil and stain resistance to a fabric without affecting the shade or the integrity of the fabric. The following Steelcase Textiles are available pre-treated with soil retardant. (You do not need to select the soil-retardant option for these fabrics and incur the upcharge.)

- Jacks
- Link
- Regis
- Roulette
- Skittles
- Spyder

Soil-retardant treatment is available on all other seating fabrics at an additional upcharge per seating unit. To order this option, please select “Soil-Retardant Treatment” under “Optional Accessories.”

For soil-retardant treatment on COMs, please select “Soil-Retardant Treatment” under “Optional Accessories.” Minimums or additional yardage may be required. Please contact the vendor directly for specific information.

Extended lead times may be necessary for this service.

Contact your Steelcase Solutions Fulfillment Team Representative at 1.888.STEELCASE (1.888.783.3522).

Fire Codes

▶ See pages 254–255 for upholstery fabrics available for use with FCS modification.

Steelcase offers Fire Code Seating modification (FCS) on nearly all seating models. The most rigorous fire codes in the nation have been developed in California, and the Steelcase FCS modification is designed to meet those codes. Fire Code Seating (FCS) indicates that a product is constructed to meet the strict fire code requirements of high public occupancy areas such as theaters, meeting rooms, and lobbies. The FCS standards will meet both the State of California Home Furnishing Technical Bulletin 133 (Cal TB 133) and Boston Fire Code (BFC). Boston adopted the California Home Furnishing Technical Bulletin TB 133 test standard in 1992.

Local codes may have special requirements for upholstery.

Dimensions

▶ Page 56

Resources

Printed Materials

- ▶ Criterion Brochure (04-0011868)
- ▶ Criterion Plus Sheet (S2396)
- ▶ Criterion Testimonial Sheet (S10846)
- ▶ Seating Overview (06-0000890)

Video and Audio Materials

- ▶ Criterion User Video (S70427)

Computer Tools

- ▶ Interactive User Guide available on www.steelcase.com
- ▶ Electronic User Disk (S2305)—Windows

Dimensions

Criterion 453 Series

Overall Depth	Width	Height	Seat Depth	Functional Seat Depth	Seat Width	Seat Height from Floor	Back Width	Back Height from Seat
Criterion 453 Series								
High-Back Work Chairs								
22½"-25½"	27½"	37½"-44½"	19½"	16¼"*	19½"	16"-21"	18"	22"-24"
Mid-Back Work Chairs								
22½"-25½"	27½"	34"-41"	19½"	16¼"*	19½"	16"-21"	18"	19½"-21½"
High-Back Stools								
22½"-25½"	27½"	46"-53"	19½"	16¼"*	19½"	25"-30"	18"	22"-24"
Mid-Back Stools								
22½"-25½"	27½"	43"-50"	19½"	16¼"*	19½"	25"-30"	18"	19½"-21½"
Plus High-Back Work Chairs								
22½"-25½"	31½"	38"-45"	19¾"	18¼"	23"	17"-22"	22"	23"-25"

* Models with adjustable seat depth 15¼"-18¼".

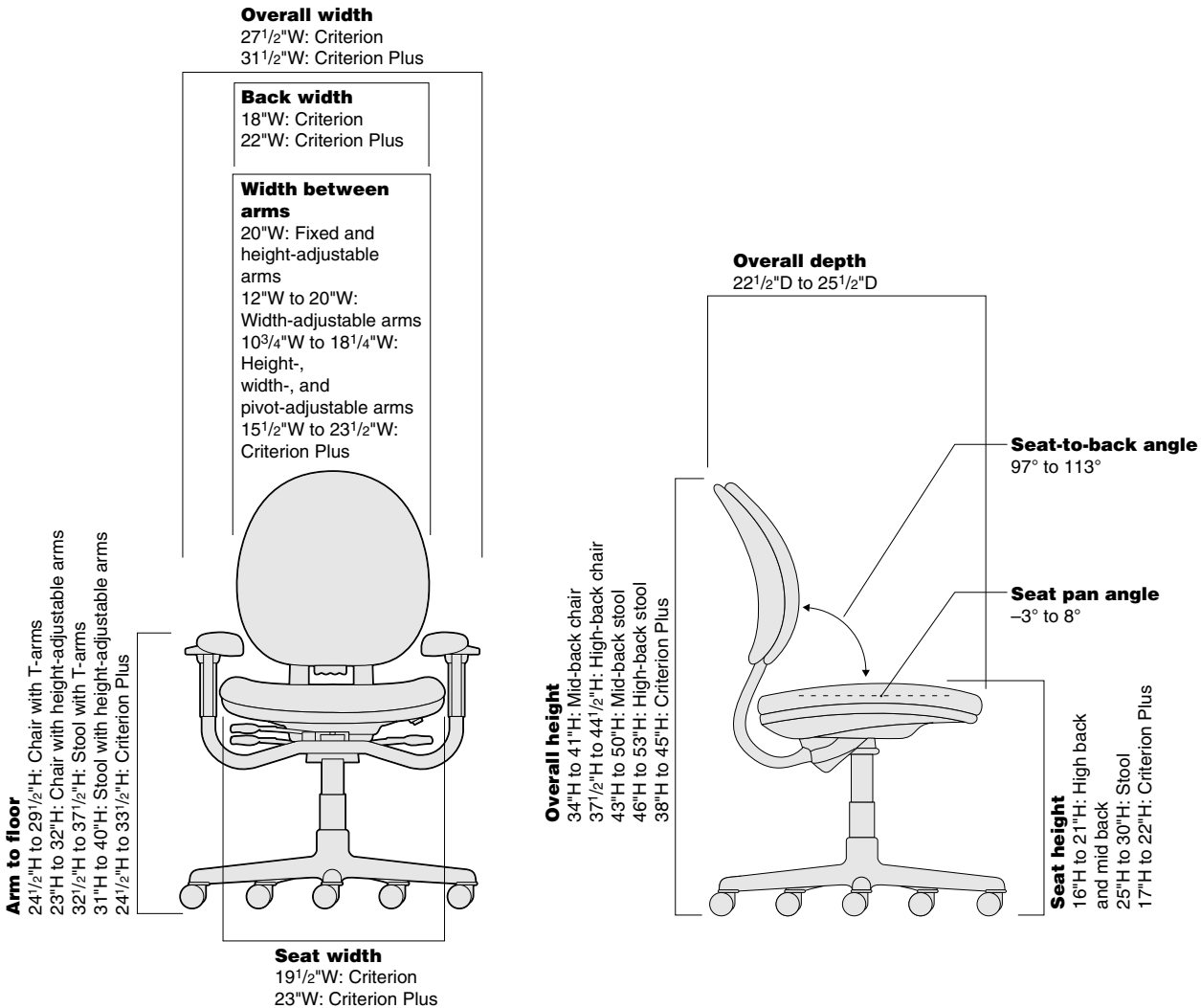

• Back Lumbar Height	• Width Between Fixed-Height and Adjustable-Height Arms	• Width Between Height- and Width-Adjustable Arms	• Width Between Height-, Width-, and Pivot-Adjustable Arms	• Arm to Floor	• Arm Height from Seat	• Arm Cap Pivot Range	• Seat Pan Angle	• Angle Between Seat and Back	• Foot Ring Width	• Foot Ring Height
High-Back Work Chairs										
8"	20"	12"-20"	10 ³ / ₄ "-18 ¹ / ₄ "	23"-32"	7"-11"	35°	-3°-+8°	97°-113°	N.A.	N.A.
Mid-Back Work Chairs										
8"	20"	12"-20"	10 ³ / ₄ "-18 ¹ / ₄ "	23"-32"	7"-11"	35°	-3°-+8°	97°-113°	N.A.	N.A.
High-Back Stools										
8"	20"	12"-20"	10 ³ / ₄ "-18 ¹ / ₄ "	31"-40"	7"-11"	35°	-3°-+8°	97°-113°	19 ¹ / ₂ "	9"-13"
Mid-Back Stools										
8"	20"	12"-20"	10 ³ / ₄ "-18 ¹ / ₄ "	31"-40"	7"-11"	35°	-3°-+8°	97°-113°	19 ¹ / ₂ "	9"-13"
Plus High-Back Work Chairs										
9"	23 ¹ / ₂ "	15 ¹ / ₂ "-23 ¹ / ₂ "	N.A.	24 ¹ / ₂ "-33 ¹ / ₂ "	7 ¹ / ₂ "-11 ¹ / ₂ "	N.A.	-3°-+8°	97°-113°	N.A.	N.A.

Criterion 453 Series High-Back Work Chairs



Tip: Molded vinyl, suffix **V**, has been replaced with sewn upholstery, suffix **S**.

Tip: Always add suffixes in alphabetical order when specifying options to Criterion seating.

Tip: Fire Code Seating (FCS) option is available only on models with both adjustable seat depth (**D** suffix) and 6205 Black plastic components.
▶ See pages 254–255 for upholstery fabric choices.

Standard Includes	Required to Specify
<ul style="list-style-type: none"> ▶ Need help? Product details, page 52 • Back height adjustment • Seat angle adjustment • Variable back stop • Back tension adjustment • Arms, if selected: plastic color to match base • Outer back and outer seat: plastic color • Upholstery: fabric price group 1 • Five-arm base: plastic color • 2½"-diameter, hard composition, dual-wheel casters: plastic color to match base 	<ol style="list-style-type: none"> 1 Style number 2 Plastic color number for base, outer back, outer seat, arms, and casters 3 Fabric color number for upholstery 4 Options, if selected (see below) <p>▶ See <i>Surface Materials</i>, page 248.</p>

Options	U.S. Price	Required to Specify
Surface Materials		
Upholstery <ul style="list-style-type: none"> • Fabric price group 1 • Fabric price group 2 • Fabric price group 3 • Fabric price group 4 • Fabric price group 5 • Fabric price group 6 • Fabric price group 7 • Fabric price group 8 • Fabric price group 9 • Fabric price group 10 • Sewn upholstery • Steelcase vinyl 	No cost +\$ 20 +\$ 40 +\$ 55 +\$ 70 +\$ 85 +\$100 +\$125 +\$155 +\$175 +\$ 39 +\$ 39	Specify fabric color number. Specify fabric color number. Specify fabric color number. Specify fabric color number. Specify fabric color number. Specify fabric color number. Specify fabric color number. Specify fabric color number. Specify fabric color number. Specify fabric color number. Add suffix S to the style number. Add suffix S to the style number and specify vinyl color number. ▶ See <i>Surface Materials Reference Manual</i> to specify. Add suffix S to the style number. Add suffix F to the style number. Specify with soil-retardant treatment.
<ul style="list-style-type: none"> • Customer's Own Material (COM) • Customer's Own Vinyl (COV) • Fire Code Seating (FCS) • Soil-retardant treatment applied to upholstery fabric 	+\$ 30 +\$ 39 +\$ 55 +\$ 20	
Fully upholstered <ul style="list-style-type: none"> • Outer back 	+\$ 82	Add suffix B to the style number.
Casters <ul style="list-style-type: none"> • Soft, dual-wheel casters for use on hard floors 	+\$ 18	Specify with soft casters.
Glides <ul style="list-style-type: none"> • Plastic glide with stainless steel cap 	No cost	Specify with <i>GLD453</i> .

Specification Information

Height-, Width-, and Pivot-Adjustable Arms



• Style Number
 • U.S. Base Price

▶ Detailed dimensions, page 56

Soft Arm Caps

Pneumatic

4535331P \$1027

Pneumatic with Adjustable Seat Depth

4535331DP \$1111

▶ **Specification Information continued on next page**

US

For **164** U.S., multiply all **162** U.S. prices by 1.03.
 Multiply **164** U.S. by 1.2 for **138** Canadian price.
 ▶ See page 1 for details.

► Specification Information, continued

Specification Information

Height- and Width-Adjustable Arms



• **Style Number**
• **U.S. Base Price**

Height-Adjustable Arms



• **Style Number**
• **U.S. Base Price**

Fixed-Height Arms



• **Style Number**
• **U.S. Base Price**

Soft Arm Caps

Pneumatic

4535331W	\$1072	4535331H	\$ 972	4535331	\$ 905
-----------------	--------	-----------------	--------	----------------	--------

Pneumatic with Adjustable Seat Depth

4535331DW	\$1156	4535331DH	\$1056	4535331D	\$ 989
------------------	--------	------------------	--------	-----------------	--------

Upholstered Arm Caps

Pneumatic

4535311W	\$1127	4535311H	\$1027	4535311	\$ 960
-----------------	--------	-----------------	--------	----------------	--------

Pneumatic with Adjustable Seat Depth

4535311DW	\$1211	4535311DH	\$1111	4535311D	\$1044
------------------	--------	------------------	--------	-----------------	--------

Without Arms



• **Style Number**
• **U.S. Base Price**

Pneumatic

4535301	\$ 776
----------------	--------

Pneumatic with Adjustable Seat Depth

4535301D	\$ 860
-----------------	--------

US 

For **164** U.S., multiply all **162** U.S. prices by 1.03.
Multiply **164** U.S. by 1.2 for **138** Canadian price.
► See page 1 for details.

Criterion 453 Series Mid-Back Work Chairs



Tip: Molded vinyl, suffix **V**, has been replaced with sewn upholstery, suffix **S**.

Tip: Always add suffixes in alphabetical order when specifying options to Criterion seating.

Tip: Fire Code Seating (FCS) option is available only on models with both adjustable seat depth (**D** suffix) and 6205 Black plastic components.
▶ See pages 254–255 for upholstery fabric choices.

Standard Includes		Required to Specify
▶ Need help? Product details, page 52	<ul style="list-style-type: none"> • Back height adjustment • Seat angle adjustment • Variable back stop • Back tension adjustment • Arms, if selected: plastic color to match base • Outer back and outer seat: plastic color • Upholstery: fabric price group 1 • Five-arm base: plastic color • 2½"-diameter, hard composition, dual-wheel casters: plastic color to match base 	1 Style number 2 Plastic color number for base, outer back, outer seat, arms, and casters 3 Fabric color number for upholstery 4 Options, if selected (see below) ▶ See <i>Surface Materials</i> , page 248.

Options	U.S. Price	Required to Specify
Surface Materials <ul style="list-style-type: none"> • Fabric price group 1 • Fabric price group 2 • Fabric price group 3 • Fabric price group 4 • Fabric price group 5 • Fabric price group 6 • Fabric price group 7 • Fabric price group 8 • Fabric price group 9 • Fabric price group 10 • Sewn upholstery • Steelcase vinyl 	No cost +\$ 20 +\$ 40 +\$ 55 +\$ 70 +\$ 85 +\$100 +\$125 +\$155 +\$175 +\$ 39 +\$ 39 +\$ 30 +\$ 39 +\$ 55 +\$ 20	Specify fabric color number. Specify fabric color number. Specify fabric color number. Specify fabric color number. Specify fabric color number. Specify fabric color number. Specify fabric color number. Specify fabric color number. Specify fabric color number. Specify fabric color number. Specify fabric color number. Add suffix S to the style number. Add suffix S to the style number and specify vinyl color number. ▶ See <i>Surface Materials Reference Manual</i> to specify. Add suffix S to the style number. Add suffix F to the style number. Specify with <i>soil-retardant treatment</i> .
Fully upholstered <ul style="list-style-type: none"> • Outer back 	+\$ 82	Add suffix B to the style number.
Casters <ul style="list-style-type: none"> • Soft, dual-wheel casters for use on hard floors 	+\$ 18	Specify with <i>soft casters</i> .
Glides <ul style="list-style-type: none"> • Plastic glide with stainless steel cap 	No cost	Specify with <i>GLD453</i> .

Specification Information

Height-, Width-, and Pivot-Adjustable Arms



• Style Number
 • U.S. Base Price

▶ Detailed dimensions, page 56



For **164** U.S., multiply all **162** U.S. prices by 1.03.
 Multiply **164** U.S. by 1.2 for **138** Canadian price.
 ▶ See page 1 for details.

Soft Arm Caps

Pneumatic

4535330P \$ 978

Pneumatic with Adjustable Seat Depth

4535330DP \$1062

▶ Specification Information continued on next page

► Specification Information, continued

Specification Information

Height- and Width Adjustable Arms



• **Style Number**
.....
.....
.....
.....
.....
.....

• **U.S. Base Price**
.....
.....
.....
.....
.....
.....

Height-Adjustable Arms



• **Style Number**
.....
.....
.....
.....
.....
.....

• **U.S. Base Price**
.....
.....
.....
.....
.....
.....

Fixed-Height Arms



• **Style Number**
.....
.....
.....
.....
.....
.....

• **U.S. Base Price**
.....
.....
.....
.....
.....
.....

Soft Arm Caps

Pneumatic

4535330W	\$1023	4535330H	\$ 923	4535330	\$856
-----------------	--------	-----------------	--------	----------------	-------

Pneumatic with Adjustable Seat Depth

4535330DW	\$1107	4535330DH	\$1007	4535330D	\$940
------------------	--------	------------------	--------	-----------------	-------

Upholstered Arm Caps

Pneumatic

4535310W	\$1078	4535310H	\$ 978	4535310	\$911
-----------------	--------	-----------------	--------	----------------	-------

Pneumatic with Adjustable Seat Depth

4535310DW	\$1162	4535310DH	\$1062	4535310D	\$995
------------------	--------	------------------	--------	-----------------	-------

Without Arms



• **Style Number**
.....
.....
.....
.....
.....
.....

• **U.S. Base Price**
.....
.....
.....
.....
.....
.....

Pneumatic

4535300	\$ 727
----------------	--------

Pneumatic with Adjustable Seat Depth

4535300D	\$ 811
-----------------	--------

US 

For **164** U.S., multiply all **162** U.S. prices by 1.03.
Multiply **164** U.S. by 1.2 for **138** Canadian price.
► See page 1 for details.

Criterion 453 Series High-Back Stools



Tip: Molded vinyl, suffix **V**, has been replaced with sewn upholstery, suffix **S**.

Tip: Always add suffixes in alphabetical order when specifying options to Criterion seating.

Tip: Fire Code Seating (FCS) option is available only on models with both adjustable seat depth (**D** suffix) and 6205 Black plastic components.
 ▶ See pages 254–255 for upholstery fabric choices.

Standard Includes		Required to Specify
▶ Need help? Product details, page 52	<ul style="list-style-type: none"> • Back height adjustment • Seat angle adjustment • Variable back stop • Back tension adjustment • Arms, if selected: plastic color to match base • Outer back and outer seat: plastic color • Upholstery: fabric price group 1 • Five-arm base: plastic color • Foot ring: plastic color • 2½"-diameter, hard composition, dual-wheel casters: plastic color to match base 	1 Style number 2 Plastic color number for base, foot ring, outer back, outer seat, arms, and casters 3 Fabric color number for upholstery 4 Options, if selected (see below) ▶ See <i>Surface Materials</i> , page 248.

	Options	U.S. Price	Required to Specify
Surface Materials	Upholstery		
	• Fabric price group 1	No cost	Specify fabric color number.
	• Fabric price group 2	+\$ 20	Specify fabric color number.
	• Fabric price group 3	+\$ 40	Specify fabric color number.
	• Fabric price group 4	+\$ 55	Specify fabric color number.
	• Fabric price group 5	+\$ 70	Specify fabric color number.
	• Fabric price group 6	+\$ 85	Specify fabric color number.
	• Fabric price group 7	+\$100	Specify fabric color number.
	• Fabric price group 8	+\$125	Specify fabric color number.
	• Fabric price group 9	+\$155	Specify fabric color number.
• Fabric price group 10	+\$175	Specify fabric color number.	
• Sewn upholstery	+\$ 39	Add suffix S to the style number.	
• Steelcase vinyl	+\$ 39	Add suffix S to the style number and specify vinyl color number.	
	• Customer's Own Material	+\$ 30 (COM)	▶ See <i>Surface Materials Reference Manual</i> to specify.
	• Customer's Own Vinyl (COV)	+\$ 39	Add suffix S to the style number.
	• Fire Code Seating (FCS)	+\$ 55	Add suffix F to the style number.
	• Soil-retardant treatment applied to upholstery fabric	+\$ 20	Specify with <i>soil-retardant treatment</i> .
	Fully upholstered		
	• Outer back	+\$ 82	Add suffix B to the style number.
	Height-adjustable foot ring		
	• Polished Chrome foot ring	+\$ 32	Specify with <i>9201 Polished Chrome foot ring</i> .
Casters	• Soft, dual-wheel casters for use on hard floors	+\$ 18	Specify with <i>soft casters</i> .
Glides	• Plastic glide with stainless steel cap	No cost	Specify with <i>GLD453</i> .

Specification Information

Height-, Width-, and Pivot-Adjustable Arms



Style Number	U.S. Base Price

Soft Arm Caps

Pneumatic

4537331P \$1225

Pneumatic with Adjustable Seat Depth

4537331DP \$1309

▶ Specification Information continued on next page

▶ Detailed dimensions, page 56



For **164** U.S., multiply all **162** U.S. prices by 1.03.
 Multiply **164** U.S. by 1.2 for **138** Canadian price.
 ▶ See page 1 for details.

► Specification Information, continued

Specification Information

Height- and Width-Adjustable Arms



• **Style Number**
• **U.S. Base Price**

Height-Adjustable Arms



• **Style Number**
• **U.S. Base Price**

Fixed-Height Arms



• **Style Number**
• **U.S. Base Price**

Soft Arm Caps

Pneumatic

4537331W	\$1270	4537331H	\$1170	4537331	\$1103
-----------------	--------	-----------------	--------	----------------	--------

Pneumatic with Adjustable Seat Depth

4537331DW	\$1354	4537331DH	\$1254	4537331D	\$1187
------------------	--------	------------------	--------	-----------------	--------

Upholstered Arm Caps

Pneumatic

4537311W	\$1325	4537311H	\$1225	4537311	\$1158
-----------------	--------	-----------------	--------	----------------	--------

Pneumatic with Adjustable Seat Depth

4537311DW	\$1409	4537311DH	\$1309	4537311D	\$1242
------------------	--------	------------------	--------	-----------------	--------

Without Arms



• **Style Number**
• **U.S. Base Price**

Pneumatic

4537301	\$ 974
----------------	--------

Pneumatic with Adjustable Seat Depth

4537301D	\$1058
-----------------	--------

US 

For **164** U.S., multiply all **162** U.S. prices by 1.03.
Multiply **164** U.S. by 1.2 for **138** Canadian price.
► See page 1 for details.

Criterion 453 Series Mid-Back Stools



Tip: Molded vinyl, suffix **V**, has been replaced with sewn upholstery, suffix **S**.

Tip: Always add suffixes in alphabetical order when specifying options to Criterion seating.

Tip: Fire Code Seating (FCS) option is available only on models with both adjustable seat depth (**D** suffix) and 6205 Black plastic components.
▶ See pages 254–255 for upholstery fabric choices.

Standard Includes	Required to Specify
<ul style="list-style-type: none"> ▶ Need help? Product details, page 52 • Back height adjustment • Seat angle adjustment • Variable back stop • Back tension adjustment • Arms, if selected: plastic color to match base • Outer back and outer seat: plastic color • Upholstery: fabric price group 1 • Five-arm base: plastic color • Foot ring: plastic color • 2½"-diameter, hard composition, dual-wheel casters: plastic color to match base 	<ol style="list-style-type: none"> 1 Style number 2 Plastic color number for base, foot ring, outer back, outer seat, arms, and casters 3 Fabric color number for upholstery 4 Options, if selected (see below) <p>▶ See <i>Surface Materials</i>, page 248.</p>

Options	U.S. Price	Required to Specify
Surface Materials		
Upholstery <ul style="list-style-type: none"> • Fabric price group 1 • Fabric price group 2 • Fabric price group 3 • Fabric price group 4 • Fabric price group 5 • Fabric price group 6 • Fabric price group 7 • Fabric price group 8 • Fabric price group 9 • Fabric price group 10 • Sewn upholstery • Steelcase vinyl 	No cost +\$ 20 +\$ 40 +\$ 55 +\$ 70 +\$ 85 +\$100 +\$125 +\$155 +\$175 +\$ 39 +\$ 39	Specify fabric color number. Specify fabric color number. Specify fabric color number. Specify fabric color number. Specify fabric color number. Specify fabric color number. Specify fabric color number. Specify fabric color number. Specify fabric color number. Specify fabric color number. Add suffix S to the style number. Add suffix S to the style number and specify vinyl color number. ▶ See <i>Surface Materials Reference Manual</i> to specify. Add suffix S to the style number. Add suffix F to the style number. Specify with <i>soil-retardant treatment</i> .
<ul style="list-style-type: none"> • Customer's Own Material (COM) • Customer's Own Vinyl (COV) • Fire Code Seating (FCS) • Soil-retardant treatment applied to upholstery fabric 	+\$ 30 +\$ 39 +\$ 55 +\$ 20	
Fully upholstered <ul style="list-style-type: none"> • Outer back 	+\$ 82	Add suffix B to the style number.
Height-adjustable foot ring <ul style="list-style-type: none"> • Polished Chrome foot ring 	+\$ 32	Specify with <i>9201 Polished Chrome foot ring</i> .
Casters <ul style="list-style-type: none"> • Soft, dual-wheel casters for use on hard floors 	+\$ 18	Specify with <i>soft casters</i> .
Glides <ul style="list-style-type: none"> • Plastic glide with stainless steel cap 	No cost	Specify with <i>GLD453</i> .

Specification Information

Height-, Width-, and Pivot-Adjustable Arms



Style Number	U.S. Base Price

▶ Detailed dimensions, page 56

Soft Arm Caps

Pneumatic

4537330P \$1176

Pneumatic with Adjustable Seat Depth

4537330DP \$1260

▶ Specification Information continued on next page



For **164** U.S., multiply all **162** U.S. prices by 1.03. Multiply **164** U.S. by 1.2 for **138** Canadian price.
▶ See page 1 for details.

► Specification Information, continued

Specification Information

Height- and Width-Adjustable Arms



• Style Number
• U.S. Base Price

Height-Adjustable Arms



• Style Number
• U.S. Base Price

Fixed-Height Arms



• Style Number
• U.S. Base Price

Soft Arm Caps

Pneumatic

4537330W	\$1221	4537330H	\$1121	4537330	\$1054
-----------------	--------	-----------------	--------	----------------	--------

Pneumatic with Adjustable Seat Depth

4537330DW	\$1305	4537330DH	\$1205	4537330D	\$1138
------------------	--------	------------------	--------	-----------------	--------

Upholstered Arm Caps

Pneumatic

4537310W	\$1276	4537310H	\$1176	4537310	\$1109
-----------------	--------	-----------------	--------	----------------	--------

Pneumatic with Adjustable Seat Depth

4537310DW	\$1360	4537310DH	\$1260	4537310D	\$1193
------------------	--------	------------------	--------	-----------------	--------

Without Arms

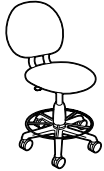

• Style Number
• U.S. Base Price

Pneumatic

4537300	\$ 925
----------------	--------

Pneumatic with Adjustable Seat Depth

4537300D	\$1009
-----------------	--------

US 

For **164** U.S., multiply all **162** U.S. prices by 1.03.
Multiply **164** U.S. by 1.2 for **138** Canadian price.
► See page 1 for details.

Criterion Plus 453 Series High-Back Work Chairs



Tip: Criterion Plus is available with a fully upholstered outer back only.

Tip: Height-, width-, and pivot-adjustable arms are not available on Criterion Plus.

Tip: Fire Code Seating (FCS) option is available only on models with 6205 Black plastic components.
 ▶ See pages 254–255 for upholstery fabric choices.

Standard Includes	Required to Specify
<ul style="list-style-type: none"> ▶ Need help? Product details, page 52 • Back height adjustment • Seat angle adjustment • Manual seat depth adjustment • Back tension adjustment • Upright back lock • Arms, if selected: plastic color to match base • Sewn upholstery • Upholstery: fabric price group 1 • Outer back: upholstery • Outer seat: plastic color • Five-arm base: plastic color • 2½"-diameter, hard composition, dual-wheel casters: plastic color to match base 	<ul style="list-style-type: none"> 1 Style number 2 Plastic color number for base, outer seat, arms, and casters 3 Fabric color number for upholstery 4 Options, if selected (see below) ▶ See <i>Surface Materials</i>, page 248.

		U.S. Price	Required to Specify
Surface Materials	Upholstery		
	<ul style="list-style-type: none"> • Fabric price group 1 • Fabric price group 2 • Fabric price group 3 • Fabric price group 4 • Fabric price group 5 • Fabric price group 6 • Fabric price group 7 • Fabric price group 8 • Fabric price group 9 • Fabric price group 10 • Customer's Own Material (COM) • Steelcase leather upholstery • Fire Code Seating (FCS) • Soil-retardant treatment applied to upholstery fabric 	<ul style="list-style-type: none"> No cost +\$ 20 +\$ 40 +\$ 55 +\$ 70 +\$ 85 +\$100 +\$125 +\$155 +\$175 +\$ 30 +\$266 +\$ 55 +\$ 20 	<ul style="list-style-type: none"> Specify fabric color number. Specify fabric color number. Specify fabric color number. Specify fabric color number. Specify fabric color number. Specify fabric color number. Specify fabric color number. Specify fabric color number. Specify fabric color number. Specify fabric color number. ▶ See <i>Surface Materials Reference Manual</i> to specify. Specify leather color number. Add suffix F to the style number. Specify <i>with soil-retardant treatment</i>.
Casters	<ul style="list-style-type: none"> • Soft, dual-wheel casters for use on hard floors 	<ul style="list-style-type: none"> +\$ 18 	<ul style="list-style-type: none"> Specify <i>with soft casters</i>.

▶ Detailed dimensions, page 56

US

For **164** U.S., multiply all **162** U.S. prices by 1.03.
 Multiply **164** U.S. by 1.2 for **138** Canadian price.
 ▶ See page 1 for details.

Specification Information

Height- and Width-Adjustable Arms



• **Style Number**
• **U.S. Base Price**

Height-Adjustable Arms



• **Style Number**
• **U.S. Base Price**

Fixed-Height Arms



• **Style Number**
• **U.S. Base Price**

Soft Arm Caps

Pneumatic

4539331BW	\$1721	4539331BH	\$1665	4539331B	\$1598
------------------	--------	------------------	--------	-----------------	--------

Upholstered Arm Caps

Pneumatic

4539311BW	\$1776	4539311BH	\$1720	4539311B	\$1653
------------------	--------	------------------	--------	-----------------	--------

Without Arms



• **Style Number**
• **U.S. Base Price**

Pneumatic

4539301B	\$1469
-----------------	--------

US 
For **164** U.S., multiply all **162** U.S. prices by 1.03.
Multiply **164** U.S. by 1.2 for **138** Canadian price.
▶ See page 1 for details.



Understanding and Specifying Think 465 Series Work Chairs

Understanding Think 465 Series

Details	70
Dimensions	74

Specifying Think 465 Series

Design Packages

3D Knit on Back with Vibe Standard Upholstery on Seat	76
3D Knit on Back with Vibe Sewn Upholstery on Seat	77

Work Chairs with Arms

3D Knit with Standard Upholstery on Seat	78
3D Knit with Sewn Upholstery on Seat	80
Standard Upholstery	82
Sewn Upholstery	84

Work Chairs, Armless

3D Knit with Standard Upholstery on Seat	86
3D Knit with Sewn Upholstery on Seat	88
Standard Upholstery	90
Sewn Upholstery	92

Work Chairs

Highly adjustable task seating offers maximum personalization for people who sit most of the day performing repetitive tasks. By making a series of simple adjustments, you can customize the chair to your body, preferences, and tasks. These chairs provide continuous, stable, task-oriented comfort, and can be quickly adjusted to support you in upright, forward, and reclining work postures.

- Leap 462 Series
- Leap 464 Series WorkLounge
- Siento 499 Series
- Criterion 453 Series
- Think 465 Series
- Drive 461 Series
- Jersey Series
- Sensor 458 Series

Adjustability Features

► See page 11 for a comparison to other chairs. **Think 465 Series**

Mechanisms

Your Power™ ●

Seat Adjustments

Pneumatic height ●

Passive seat edge angle ●

Seat depth ●

Back Adjustments

Lumbar height ●

Arm Adjustments

Arm depth ●

Arm height ●

Arm pivot ●

Arm width ●

Other Features

Soft-wheel casters ●

Think 465 Series

Think—the chair with a brain and a conscience.

Back frame and seat shell are plastic.

Arm caps can pivot independently 27° in and 27° out to accommodate individual user preferences, and provide 4" width adjustment.

Lumbar height adjusts over 4¼" to provide additional lower back support and is available as an option.

Your Preference back control provides four settings for the user's personal preference and work style.

Seat height adjusts within a 5" range with a pneumatic adjustment mechanism. A 4" range is available as an option.

Casters have hard, dual-wheels that roll smoothly on carpets. They are 2½" for increased mobility. Soft, dual-wheel casters are available as an option for use on hard floors or chair mats.

Arm width adjust 4½" overall to support forearms in neutral position.

Arm height can adjust independently within a 4" range to help relieve upper back and shoulder fatigue.

Arm depth can retract 3" to allow user to get closer to the worksurface.

Seat edge angle naturally tilts to relieve pressure under the user's thighs.

Seat depth adjusts within a 3" range to accommodate users of varying leg lengths.

Five-arm base is available in plastic or polished aluminum.

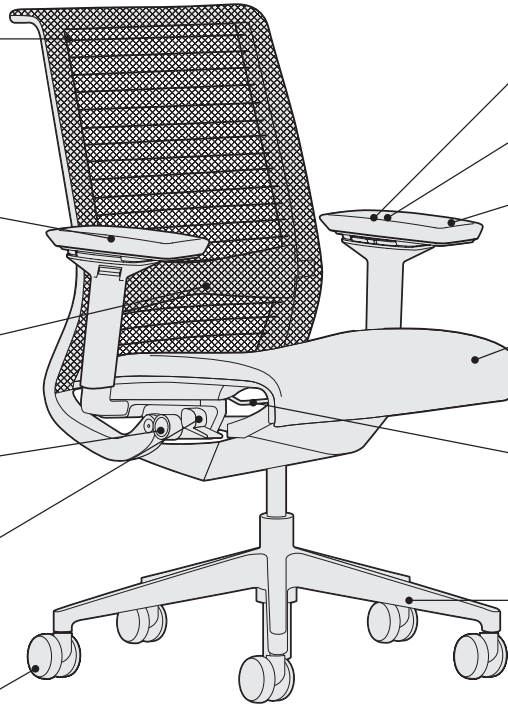

Product Details

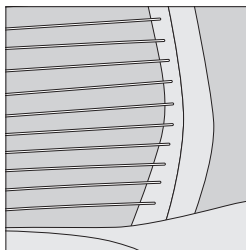

Your Profile™ seat and back have flexors that dynamically and independently follow the movements of the user.

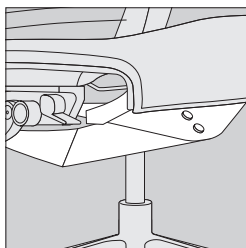

Your Power™ mechanism is weight-activated, with a natural fluid motion that keeps users oriented to their work.



Your Preference™ back control has four settings that allow for the user's personal preference and work style.

Chairs are available without arms, with fixed arms, or with height-, width-, pivot-, and depth-adjustable arms.

Three design packages are available for the Think chair—two highly adjustable packages and one with limited adjustability. 3D Knit is on the back and Designtex Vibe is on the seat. Plastic color choice for frame, seat shell, and base may be specified.

Adjustability instructions are included with every chair.

Seating Specification Guide

Adjustment Features

Seat Adjustments

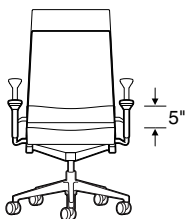

Seat height adjusts pneumatically. To lower, hold handle up while seated. To raise, hold handle up and keep your weight off the chair. Standard range of adjustability is 5" from 16"H to 21"H. A 4" range of adjustability (15"H to 19"H) is available as an option.

Seat edge angle relieves pressure under the user's thighs. The combination of seat flexors with a passive front seat edge helps properly support the angle of the user's leg and thigh without compromising pelvic support.

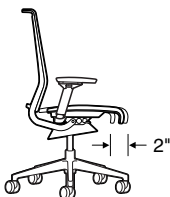

Seat depth adjusts 2" (15"–17") by pulling handle up. Slide seat forward or back to accommodate various leg lengths. Release handle to lock.

Back Adjustments

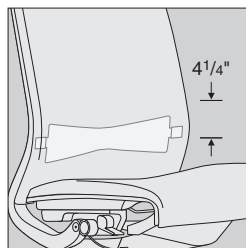

Lumbar height adjusts 4 1/4" (6" to 10 1/4" from seat) by grabbing exposed tabs and sliding the lumbar support up or down. Available as an option on work chairs.



Weight-activated setting

Boosted setting



Mid-stop recline setting

Upright setting

Your Preference™ control has four settings: (1) weight-activated setting; (2) boosted setting that has approximately 20% more resistance than your body is providing; (3) mid-stop recline setting; and (4) an upright setting.

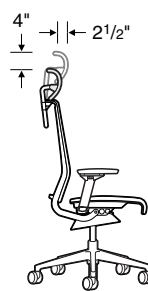

Headrest (option) adjusts 4" vertically and 2 1/2" horizontally (front to back) to support the head and neck of the user in both upright and recline postures. Whether ordered initially or at a later date, the headrest ships in its own carton and must be field-installed.

Arm Adjustments

Height-, width-, pivot-, and depth-adjustable arms come standard on all arm models of chairs. Fixed arms are an option. Also available armless.

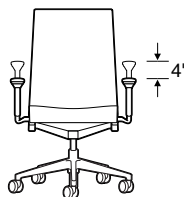

Arm height adjusts independently within a range of 4" (7"–11" from the seat). Push button on outside and under arm cap in while moving arms up or down. Releasing buttons locks arms in position.

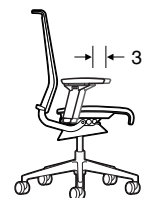

Arm depth adjusts by sliding armcaps back 3". Friction-fit mechanism keeps arms in position. Armcaps adjust independently within a 3" range. Arm depth adjusts only when arm width is adjusted at widest position.

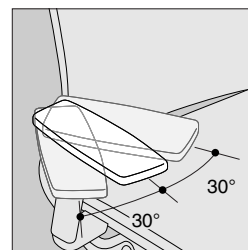

Arms pivot independently, 30° inward and outward.

Arm width can be adjusted 2 1/4" each, 4 1/2" overall. Grasp arm cap and move in or out.

Other Features

Soft-wheel casters for hard floors are available for specific applications.

Surface Materials

► See surface materials on page 248 for specific availability or refer to the *Surface Materials Reference Manual* for further information.

Upholstery

- Fabric
- Fabric with soil-retardant treatment (option)
- 3D Knit (back only)
- Leather
- Vinyl

Hard components

(frame, seat shell, base, headrest, and arm uprights)

- 6205 Black
- 6694 Slate

Polished aluminum base

is standard on some models.

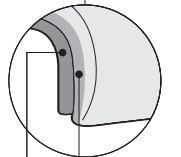

Foundation fabric

Plastic seat shell

Standard-upholstery uses foundation fabric (which is a default of the specified plastic color). It is partially visible on the sides of the seat and back cushions.

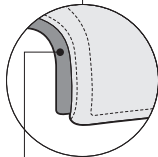

Plastic seat shell

Sewn-upholstery specified on the seat and back is also found on the sides of the seat and back cushions with a boxed stitch detail. Fabric can be specified with standard or sewn upholstery.

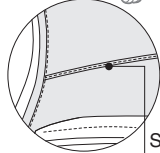
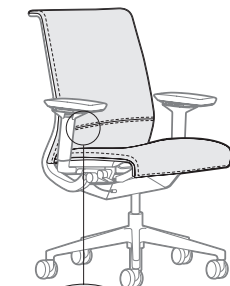

Stitch Detail

Sewn-upholstery for leather and vinyl materials feature an additional stitch detail across the lumbar region of the back cushion.

All Steelcase seating with standard upholstery fabrics complies with requirements of the BIFMA First Generation Voluntary Upholstered Furniture Flammability Standard, as well as the State of California Technical Bulletin 117. All standard seating is labeled to be in compliance with California TB117.

► See the *Surface Materials Reference Manual* for further detail about programs and services offered for seating.

The Customer's Own Material (COM) Program

offers the opportunity for customers to select fabrics that are not offered through the standard Steelcase surface materials program for use on Steelcase products. Through the COM program, Steelcase will test your materials for application on Steelcase products. Once approved, you can place your order. Steelcase will facilitate the entire ordering process and give you a production schedule. Steelcase will order the COM fabric directly from the textile manufacturer. For up-to-date information regarding fabric test results for all COM fabrics and details regarding yardage requirements for most Seating lines, visit the COM Web site. To locate the COM Web site:

- Visit www.steelcase.com
- Click on "Knowledge & Design"
- Select "Customer's Own Material"

Soil retardants are treatments that provide long-term soil and stain resistance to a fabric without affecting the shade or the integrity of the fabric. The following Steelcase Textiles are available pre-treated with soil retardant. (You do not need to select the soil-retardant option for these fabrics and incur the \$20 upcharge.)

- Jacks
- Link
- Regis
- Roulette
- Skittles
- Spyder

Soil-retardant treatment is available on all other seating fabrics at an additional \$20 U.S. per seating unit. To order this option, please select "Soil-Retardant Treatment" under "Optional Accessories."

For soil-retardant treatment on COMs, please select "Soil-Retardant Treatment" under "Optional Accessories." Minimums or additional yardage may be required. Please contact the vendor directly for specific information.

Extended lead times may be necessary for this service.

Contact your Steelcase Solutions Fulfillment Team Representative at 1.888.STEELCASE (1.888.783.3522).

Fire Codes

► See pages 254–255 for upholstery fabrics available for use with FCS modification.

Steelcase offers Fire Code Seating modification (FCS) on nearly all seating models. The most rigorous fire codes in the nation have been developed in California, and the Steelcase FCS modification is designed to meet those codes. Fire Code Seating (FCS) indicates that a product is constructed to meet the strict fire code requirements of high public occupancy areas such as theaters, meeting rooms, and lobbies. The FCS standards will meet both the State of California Home Furnishing Technical Bulletin 133 (Cal TB 133) and Boston Fire Code (BFC). Boston adopted the California Home Furnishing Technical Bulletin TB 133 test standard in 1992.

Local codes may have special requirements for upholstery.

Dimensions

► Page 74

Resources

Printed Materials

- Think Product Brochure (04-0011844)
- Think Environmental Brochure (04-0011852)
- Think Environmental Product Declaration (EPD) (04-0012421) (PDF only)
- Think Pocket Sales Card (04-0011847)
- Think Customer Powerpoint (Slides/Script) (04-0011848)
- Think Hang Tag (04-0011853)
- Seating Sales & Dealer Guide (update) (03-0003909)
- Think National Ad Reprint (04-0011856)

Audiovisual Materials

- Think Design Story–Video (04-0011845)
- Think Design Story–DVD (04-0011846)
- Think Model Sales Presentation–DVD (04-0012577)
- Think Model Sales Presentation–VHS (04-0012578)
- Think Model Sales Presentation–audio CD (04-0012579)

Dimensions

Think 465 Series

Features	Overall Depth	Width	Height	Seat Depth	Functional Seat Depth	Seat Width	Seat Height from Floor	Back Width	Back Height from Seat	Lumbar Height from Seat
Think 465 Series										
Arms	23" to 25"	27"	37 ¹ / ₈ " to 41 ³ / ₄ "	18 ¹ / ₂ "	15" to 17"	19 ³ / ₄ "	16" to 21" (15" to 19" optional)	19"	22 ³ / ₄ "	6" to 10 ¹ / ₄ "

*Arms may be tool-adjusted inward 1" to accommodate the user's preference.

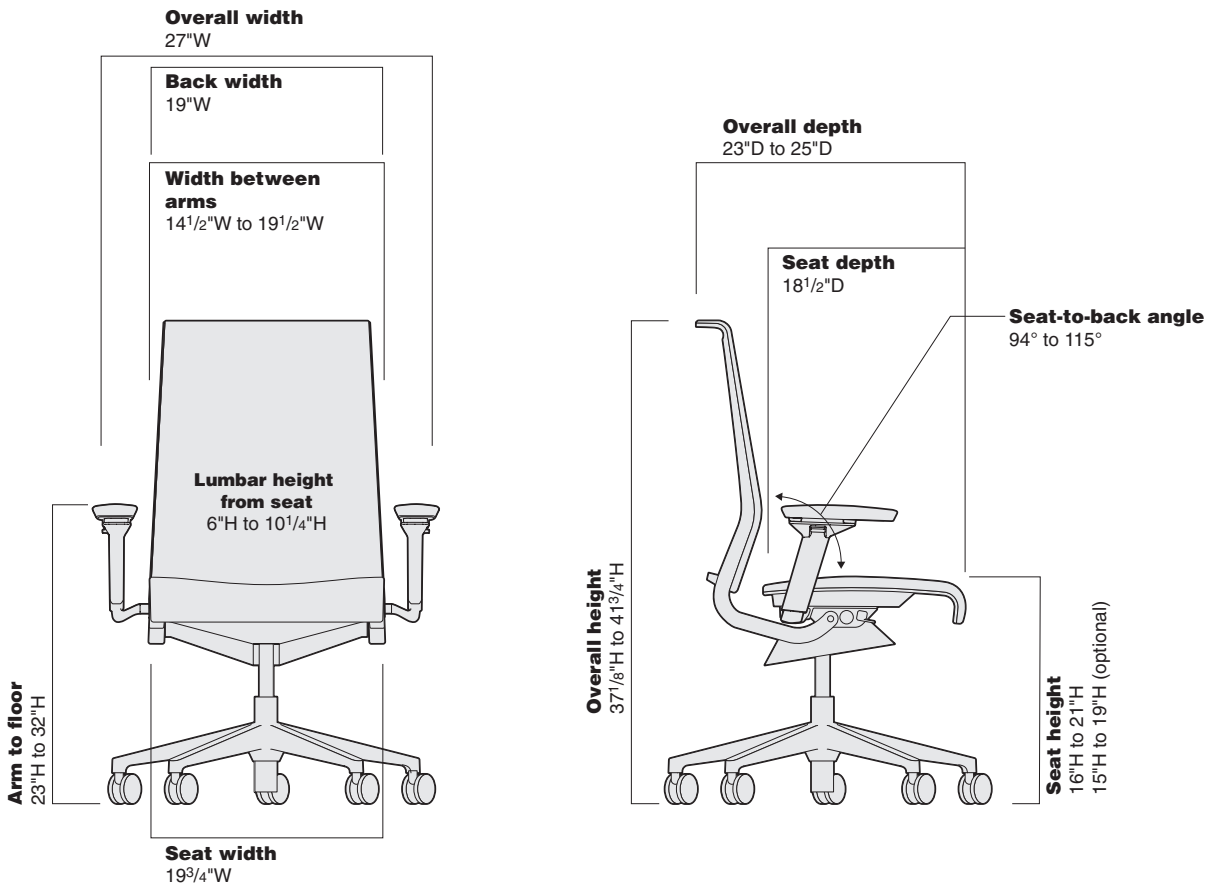

• Width • Between • Adjustable • Arms	• Width • Between • Fixed • Arms	• Arm • to • Floor	• Arm • Height • from • Seat	• Arm • Height • from Seat • for Fixed • Arms	• Arm Cap • Pivot • Range	• Angle • Between • Seat and • Back	• Weight	• Headrest • Height • Adjustment • Range	• Headrest • Depth • Adjustment • Range
14½" to 19½"	19"	23" to 32"	7" to 11"	10½"	27° inward, 27° outward	94° to 115°	31	4"	2½"

*Arms may be tool-adjusted inward 1" to accommodate the user's preference.

Think 465 Series Design Package Work Chairs



with Arms

3D Knit on Back with Vibe Standard Upholstery on Seat



Standard Includes		Required to Specify
<ul style="list-style-type: none"> ▶ Need help? Product details, page 70 	<ul style="list-style-type: none"> • 5" pneumatic seat-height adjustment (16"-21") • Your Preference™ control • Seat edge angle • Frame, seat shell, and five-arm base: plastic • 3" seat depth adjustment • Height-, width-, pivot-, and depth-adjustable arms • 3D Knit on back and Designtex Vibe on seat • Standard upholstery design on seat • 2½"-diameter, hard-composition, dual-wheel casters: black 	<ol style="list-style-type: none"> 1 Style number 2 Plastic color for frame, seat shell, and base 3 3D Knit color for back 4 Fabric color number for upholstery on seat <ul style="list-style-type: none"> ▶ See <i>Surface Materials</i>, page 248.

Specification Information

			
• Style Number	• U.S. Price	• Style Number	• U.S. Price
With Lumbar		Without Lumbar	
465THINKS4U	\$970	465THINKS	\$920

▶ Detailed dimensions, page 74

US 

For **164** U.S., multiply all **162** U.S. prices by 1.03.
 Multiply **164** U.S. by 1.2 for **138** Canadian price.
 ▶ See page 1 for details.

Think 465 Series Design Package Work Chairs

Think 465 Series Design
Package Work Chairs

with Arms

3D Knit on Back with Vibe Sewn Upholstery on Seat



Standard Includes		Required to Specify
<ul style="list-style-type: none"> ▶ Need help? Product details, page 70 	<ul style="list-style-type: none"> • 5" pneumatic seat-height adjustment (16"–21") • Your Preference™ control • Seat edge angle • Frame and seat shell: plastic • Polished Aluminum base • 3" seat depth adjustment • Fixed arms • 3D Knit on back and Designtex Vibe on seat • Sewn upholstery design on seat • 2½"-diameter, hard-composition, dual-wheel casters: black 	<ul style="list-style-type: none"> 1 Style number 2 Plastic color for frame and seat shell 3 3D Knit color for back 4 Fabric color number for upholstery on seat ▶ See <i>Surface Materials</i>, page 248.

Specification Information	
Style Number	U.S. Price
465THINK	\$970

▶ Detailed dimensions, page 74

US

For **164** U.S., multiply all **162** U.S. prices by 1.03.
 Multiply **164** U.S. by 1.2 for **138** Canadian price.
 ▶ See page 1 for details.

Think 465 Series

Think 465 Series Work Chairs

with Arms

3D Knit with Standard Upholstery on Seat



Tip: Fire Code Seating (FCS) option is available with certain upholstery fabric choices only.
▶ Pages 254–255

Standard Includes		Required to Specify
▶ Need help? Product details, page 70	<ul style="list-style-type: none"> • 5" pneumatic seat-height adjustment (16"–21") • Your Preference™ control • Seat edge angle • Frame, seat shell, and five-arm base • 3" seat depth adjustment • Height-, width-, pivot-, and depth-adjustable arms • 3D Knit on back • Standard upholstery design on seat: fabric price group 1 • 2½"-diameter, hard-composition, dual-wheel casters: black 	<ol style="list-style-type: none"> 1 Style number 2 Plastic color for frame, seat shell, and base 3 3D Knit color for back 4 Fabric color number for upholstery on seat 5 Options, if selected (see below) <p>▶ See <i>Surface Materials</i>, page 248.</p>

Options	U.S. Price	Required to Specify
Surface Materials Upholstery <ul style="list-style-type: none"> • Fabric price group 1 • Fabric price group 2 • Fabric price group 3 • Fabric price group 4 • Fabric price group 5 • Fabric price group 6 • Fabric price group 7 • Fabric price group 8 • Fabric price group 9 • Fabric price group 10 • Customer's Own Material (COM) • Fire Code Seating (FCS) • Soil-retardant treatment applied to upholstery fabric 	No cost +\$ 10 +\$ 20 +\$ 28 +\$ 35 +\$ 43 +\$ 50 +\$ 63 +\$ 78 +\$ 88 No cost +\$ 55 +\$ 20	Specify fabric color number. Specify fabric color number. Specify fabric color number. Specify fabric color number. Specify fabric color number. Specify fabric color number. Specify fabric color number. Specify fabric color number. Specify fabric color number. Specify fabric color number. Specify fabric color number. ▶ See <i>Surface Materials Reference Manual</i> . Add suffix F to the style number. Specify with soil-retardant treatment.
Arms <ul style="list-style-type: none"> • Fixed arms 	–\$ 80	Specify with fixed arms.
Seat Height <ul style="list-style-type: none"> • 4" pneumatic seat-height adjustment (15"–19") 	No cost	Specify with 4" pneumatic seat-height adjustment.
Lumbar Height <ul style="list-style-type: none"> • 5" travel for additional lumbar support 	+\$ 50	Specify with adjustable lumbar height.
Casters <ul style="list-style-type: none"> • Soft, dual-wheel casters for use on hard floors 	+\$ 18	Specify with soft casters.

Specification Information			
Assembled		Ready to Assemble (Cartoned)	
			
• Style Number	• U.S. Base Price	• Style Number	• U.S. Base Price

Plastic Base			
Without Headrest			
46513100	\$920	46513101	\$920

▶ Specification Information continued on next page

▶ Detailed dimensions, page 74

US 

For **164** U.S., multiply all **162** U.S. prices by 1.03.
Multiply **164** U.S. by 1.2 for **138** Canadian price.
▶ See page 1 for details.

► Specification Information continued from previous page

Specification Information

Assembled



• Style
Number

• U.S.
Base
Price

Ready to Assemble (Cartoned)



• Style
Number

• U.S.
Base
Price

Plastic Base

With Headrest

46513110 \$1070

46513111 \$1070

Assembled



• Style
Number

• U.S.
Base
Price

Ready to Assemble (Cartoned)



• Style
Number

• U.S.
Base
Price

Aluminum Base

Without Headrest

46523100 \$1020

46523101 \$1020

Assembled



• Style
Number

• U.S.
Base
Price

Ready to Assemble (Cartoned)



• Style
Number

• U.S.
Base
Price

Aluminum Base

With Headrest

46523110 \$1170

46523111 \$1170

US 
For **164** U.S., multiply all **162** U.S. prices by 1.03.
Multiply **164** U.S. by 1.2 for **138** Canadian price.
► See page 1 for details.

Think 465 Series Work Chairs

with Arms

3D Knit with Sewn Upholstery on Seat



Standard Includes		Required to Specify
<ul style="list-style-type: none"> ▶ Need help? Product details, page 70 	<ul style="list-style-type: none"> • 5" pneumatic seat-height adjustment (16"–21") • Your Preference™ control • Seat edge angle • Frame, seat shell, and five-arm base • 3" seat depth adjustment • Height-, width-, pivot-, and depth-adjustable arms • 3D Knit on back • Sewn upholstery design on seat: fabric price group 1 • 2½"-diameter, hard-composition, dual-wheel casters: black 	<ol style="list-style-type: none"> 1 Style number 2 Plastic color for frame, seat shell, and base 3 3D Knit color for back 4 Fabric color number for upholstery on seat 5 Options, if selected (see below) <ul style="list-style-type: none"> ▶ See <i>Surface Materials</i>, page 248.

Options	U.S. Price	Required to Specify
Surface Materials <ul style="list-style-type: none"> • Fabric price group 1 • Fabric price group 2 • Fabric price group 3 • Fabric price group 4 • Fabric price group 5 • Fabric price group 6 • Fabric price group 7 • Fabric price group 8 • Fabric price group 9 • Fabric price group 10 • Steelcase leather upholstery • Customer's Own Material (COM), Customer's Own Vinyl (COV), or Customer's Own Leather (COL) • Fire Code Seating (FCS) • Soil-retardant treatment applied to upholstery fabric 	<ul style="list-style-type: none"> No cost +\$ 10 +\$ 20 +\$ 28 +\$ 35 +\$ 43 +\$ 50 +\$ 63 +\$ 78 +\$ 88 +\$140 No cost +\$ 55 +\$ 20 	<ul style="list-style-type: none"> Specify fabric color number. Specify fabric color number. Specify fabric color number. Specify fabric color number. Specify fabric color number. Specify fabric color number. Specify fabric color number. Specify fabric color number. Specify fabric color number. Specify fabric color number. Specify leather color number. ▶ See <i>Surface Materials Reference Manual</i>. Add suffix F to the style number. Specify <i>with soil-retardant treatment</i>.
Arms <ul style="list-style-type: none"> • Fixed arms 	–\$ 80	Specify <i>with fixed arms</i> .
Seat Height <ul style="list-style-type: none"> • 4" pneumatic seat-height adjustment (15"–19") 	No cost	Specify <i>with 4" pneumatic seat-height adjustment</i> .
Lumbar Height <ul style="list-style-type: none"> • 5" travel for additional lumbar support 	+\$ 50	Specify <i>with adjustable lumbar height</i> .
Casters <ul style="list-style-type: none"> • Soft, dual-wheel casters for use on hard floors 	+\$ 18	Specify <i>with soft casters</i> .

Tip: Fire Code Seating (FCS) option is available with certain upholstery fabric choices only.
▶ Pages 254–255

Specification Information

Assembled



• Style Number
• U.S. Base Price

Ready to Assemble (Cartoned)



• Style Number
• U.S. Base Price

Plastic Base

Without Headrest

46512100	\$950	46512101	\$950
----------	-------	----------	-------

▶ Specification Information continued on next page

▶ Detailed dimensions, page 74



For **164** U.S., multiply all **162** U.S. prices by 1.03. Multiply **164** U.S. by 1.2 for **138** Canadian price.
▶ See page 1 for details.

► Specification Information continued from previous page

Specification Information

Assembled



• Style
Number

• U.S.
Base
Price

Ready to Assemble (Cartoned)



• Style
Number

• U.S.
Base
Price

Plastic Base

With Headrest

46512110 \$1100

46512111 \$1100

Assembled



• Style
Number

• U.S.
Base
Price

Ready to Assemble (Cartoned)



• Style
Number

• U.S.
Base
Price

Aluminum Base

Without Headrest

46522100 \$1050

46522101 \$1050

Assembled



• Style
Number

• U.S.
Base
Price

Ready to Assemble (Cartoned)



• Style
Number

• U.S.
Base
Price

Aluminum Base

With Headrest

46522110 \$1200

46522111 \$1200

US 
For **164** U.S., multiply all
162 U.S. prices by 1.03.
Multiply **164** U.S. by 1.2 for
138 Canadian price.
► See page 1 for details.

Think 465 Series Work Chairs



with Arms
Standard Upholstery



Tip: Fire Code Seating (FCS) option is available with certain upholstery fabric choices only.
▶ Pages 254–255

Standard Includes		Required to Specify
▶ Need help? Product details, page 70	<ul style="list-style-type: none"> • 5" pneumatic seat-height adjustment (16"–21") • Your Preference™ control • Seat edge angle • Frame, seat shell, and five-arm base • 3" seat depth adjustment • Height-, width-, pivot-, and depth-adjustable arms • Standard upholstery design: fabric price group 1 • 2½"-diameter, hard-composition, dual-wheel casters: black 	<ol style="list-style-type: none"> 1 Style number 2 Plastic color for frame, seat shell, and base 3 Fabric color number for upholstery on seat and back 4 Options, if selected (see below) <p>▶ See <i>Surface Materials</i>, page 248.</p>

Options	U.S. Price	Required to Specify
Surface Materials Upholstery <ul style="list-style-type: none"> • Fabric price group 1 • Fabric price group 2 • Fabric price group 3 • Fabric price group 4 • Fabric price group 5 • Fabric price group 6 • Fabric price group 7 • Fabric price group 8 • Fabric price group 9 • Fabric price group 10 • Customer's Own Material (COM) • Fire Code Seating (FCS) • Soil-retardant treatment applied to upholstery fabric 	No cost +\$ 20 +\$ 40 +\$ 55 +\$ 70 +\$ 85 +\$100 +\$125 +\$155 +\$175 No cost +\$ 55 +\$ 20	Specify fabric color number. Specify fabric color number. Specify fabric color number. Specify fabric color number. Specify fabric color number. Specify fabric color number. Specify fabric color number. Specify fabric color number. Specify fabric color number. Specify fabric color number. ▶ See <i>Surface Materials Reference Manual</i> . Add suffix F to the style number. Specify <i>with soil-retardant treatment</i> .
Arms <ul style="list-style-type: none"> • Fixed arms 	–\$ 80	Specify <i>with fixed arms</i> .
Seat Height <ul style="list-style-type: none"> • 4" pneumatic seat-height adjustment (15"–19") 	No cost	Specify <i>with 4" pneumatic seat-height adjustment</i> .
Lumbar Height <ul style="list-style-type: none"> • 5" travel for additional lumbar support 	+\$ 50	Specify <i>with adjustable lumbar height</i> .
Casters <ul style="list-style-type: none"> • Soft, dual-wheel casters for use on hard floors 	+\$ 18	Specify <i>with soft casters</i> .

Specification Information			
Assembled		Ready to Assemble (Cartoned)	
			
• Style Number	• U.S. Base Price	• Style Number	• U.S. Base Price

Plastic Base			
Without Headrest			
46510100	\$880	46510101	\$880

▶ Specification Information continued on next page

▶ Detailed dimensions, page 74

US 

For **164** U.S., multiply all **162** U.S. prices by 1.03.
 Multiply **164** U.S. by 1.2 for **138** Canadian price.
 ▶ See page 1 for details.

► Specification Information continued from previous page

Specification Information

Assembled



• Style
Number

• U.S.
Base
Price

Ready to Assemble (Cartoned)



• Style
Number

• U.S.
Base
Price

Plastic Base

With Headrest

46510110 \$1030

46510111 \$1030

Assembled



• Style
Number

• U.S.
Base
Price

Ready to Assemble (Cartoned)



• Style
Number

• U.S.
Base
Price

Aluminum Base

Without Headrest

46520100 \$ 980

46520101 \$ 980

Assembled



• Style
Number

• U.S.
Base
Price

Ready to Assemble (Cartoned)



• Style
Number

• U.S.
Base
Price

Aluminum Base

With Headrest

46520110 \$1130

46520111 \$1130

US 
For **164** U.S., multiply all
162 U.S. prices by 1.03.
Multiply **164** U.S. by 1.2 for
138 Canadian price.
► See page 1 for details.

Think 465 Series Work Chairs

with Arms

Sewn Upholstery



Tip: Always add suffixes in alphabetical order when specifying options to Think seating.



Tip: Leather, COL, vinyl, and COV materials require an additional stitch detail across the lumbar region of the back cushion. Specify with **S** suffix.

Tip: Fire Code Seating (FCS) option is available with certain upholstery fabric choices only.
▶ Pages 254–255

Standard Includes		Required to Specify
▶ Need help? Product details, page 70	<ul style="list-style-type: none"> 5" pneumatic seat-height adjustment (16"–21") Your Preference™ control Seat edge angle Frame, seat shell, and five-arm base 3" seat depth adjustment Height-, width-, pivot-, and depth-adjustable arms Sewn upholstery design: fabric price group 1 2½"-diameter, hard-composition, dual-wheel casters: black 	<ol style="list-style-type: none"> Style number Plastic color for frame, seat shell, outer back, and base Fabric color number for upholstery on seat and back Options, if selected (see below) <p>▶ See <i>Surface Materials</i>, page 248.</p>

Options	U.S. Price	Required to Specify	
Surface Materials Upholstery <ul style="list-style-type: none"> Fabric price group 1 Fabric price group 2 Fabric price group 3 Fabric price group 4 Fabric price group 5 Fabric price group 6 Fabric price group 7 Fabric price group 8 Fabric price group 9 Fabric price group 10 Steelcase leather upholstery Steelcase vinyl Customer's Own Material (COM) Customer's Own Vinyl (COV) Customer's Own Leather (COL) Fire Code Seating (FCS) Soil-retardant treatment applied to upholstery fabric 	<ul style="list-style-type: none"> No cost +\$ 20 +\$ 40 +\$ 55 +\$ 70 +\$ 85 +\$100 +\$125 +\$155 +\$175 +\$275 No cost No cost No cost +\$ 55 +\$ 20 	<ul style="list-style-type: none"> Specify fabric color number. Specify fabric color number. Specify fabric color number. Specify fabric color number. Specify fabric color number. Specify fabric color number. Specify fabric color number. Specify fabric color number. Specify fabric color number. Specify fabric color number. Add suffix S to the style number and specify leather color number. Add suffix S to the style number and specify vinyl color number. ▶ See <i>Surface Materials Reference Manual</i>. Add suffix S to the style number and specify vinyl color number. Add suffix S to the style number and specify leather color number. Add suffix F to the style number. Specify with soil-retardant treatment. 	
Arms	<ul style="list-style-type: none"> Fixed arms 	–\$ 80	Specify with fixed arms.
Seat Height	<ul style="list-style-type: none"> 4" pneumatic seat-height adjustment (15"–19") 	No cost	Specify with 4" pneumatic seat-height adjustment.
Lumbar Height	<ul style="list-style-type: none"> 5" travel for additional lumbar support 	+\$ 50	Specify with adjustable lumbar height.
Casters	<ul style="list-style-type: none"> Soft, dual-wheel casters for use on hard floors 	+\$ 18	Specify with soft casters.

Specification Information

Assembled	Ready to Assemble (Cartoned)
	
<ul style="list-style-type: none"> • Style Number • U.S. Base Price 	<ul style="list-style-type: none"> • Style Number • U.S. Base Price

Plastic Base	
Without Headrest	
46511100	\$940
46511101	\$940

▶ Specification Information continued on next page

▶ Detailed dimensions, page 74

US 

For **164** U.S., multiply all **162** U.S. prices by 1.03. Multiply **164** U.S. by 1.2 for **138** Canadian price.
▶ See page 1 for details.

► Specification Information continued from previous page

Specification Information

Assembled



• Style
Number

• U.S.
Base
Price

Ready to Assemble (Cartoned)



• Style
Number

• U.S.
Base
Price

Plastic Base

With Headrest

46511110 \$1090

46511111 \$1090

Assembled



• Style
Number

• U.S.
Base
Price

Ready to Assemble (Cartoned)



• Style
Number

• U.S.
Base
Price

Aluminum Base

Without Headrest

46521100 \$1040

46521101 \$1040

Assembled



• Style
Number

• U.S.
Base
Price

Ready to Assemble (Cartoned)



• Style
Number

• U.S.
Base
Price

Aluminum Base

With Headrest

46521110 \$1190

46521111 \$1190

US 
For **164** U.S., multiply all
162 U.S. prices by 1.03.
Multiply **164** U.S. by 1.2 for
138 Canadian price.
► See page 1 for details.

Think 465 Series Work Chairs

Armless

3D Knit with Standard Upholstery on Seat



Standard Includes		Required to Specify
<ul style="list-style-type: none"> ▶ Need help? Product details, page 70 	<ul style="list-style-type: none"> • 5" pneumatic seat-height adjustment (16"–21") • Your Preference™ control • Seat edge angle • Frame, seat shell, and five-arm base • 3" seat depth adjustment • 3D Knit on back • Standard upholstery design on seat: fabric price group 1 • 2½"-diameter, hard-composition, dual-wheel casters: black 	<ol style="list-style-type: none"> 1 Style number 2 Plastic color for frame, seat shell, and base 3 3D Knit color for back 4 Fabric color number for upholstery on seat 5 Options, if selected (see below) <ul style="list-style-type: none"> ▶ See <i>Surface Materials</i>, page 248.

Tip: Fire Code Seating (FCS) option is available with certain upholstery fabric choices only.
▶ Pages 254–255

Options	U.S. Price	Required to Specify
Surface Materials Upholstery <ul style="list-style-type: none"> • Fabric price group 1 • Fabric price group 2 • Fabric price group 3 • Fabric price group 4 • Fabric price group 5 • Fabric price group 6 • Fabric price group 7 • Fabric price group 8 • Fabric price group 9 • Fabric price group 10 • Customer's Own Material (COM) • Fire Code Seating (FCS) • Soil-retardant treatment applied to upholstery fabric 	<ul style="list-style-type: none"> No cost +\$10 +\$20 +\$28 +\$35 +\$43 +\$50 +\$63 +\$78 +\$88 No cost +\$55 +\$20 	<ul style="list-style-type: none"> Specify fabric color number. Specify fabric color number. Specify fabric color number. Specify fabric color number. Specify fabric color number. Specify fabric color number. Specify fabric color number. Specify fabric color number. Specify fabric color number. Specify fabric color number. ▶ See <i>Surface Materials Reference Manual</i>. Add suffix F to the style number. Specify with soil-retardant treatment.
Seat Height <ul style="list-style-type: none"> • 4" pneumatic seat-height adjustment (15"–19") 	<ul style="list-style-type: none"> No cost 	<ul style="list-style-type: none"> Specify with 4" pneumatic seat-height adjustment.
Lumbar Height <ul style="list-style-type: none"> • 5" travel for additional lumbar support 	<ul style="list-style-type: none"> +\$50 	<ul style="list-style-type: none"> Specify with adjustable lumbar height.
Casters <ul style="list-style-type: none"> • Soft, dual-wheel casters for use on hard floors 	<ul style="list-style-type: none"> +\$18 	<ul style="list-style-type: none"> Specify with soft casters.

Specification Information

Assembled



• Style Number
• U.S. Base Price

Ready to Assemble (Cartoned)



• Style Number
• U.S. Base Price

Plastic Base

Without Headrest

46513000	\$720	46513001	\$720
----------	-------	----------	-------

▶ Specification Information continued on next page

▶ Detailed dimensions, page 74



For **164** U.S., multiply all **162** U.S. prices by 1.03. Multiply **164** U.S. by 1.2 for **138** Canadian price.
▶ See page 1 for details.

► Specification Information continued from previous page

Specification Information

Assembled



• Style
Number

• U.S.
Base
Price

Ready to Assemble (Cartoned)



• Style
Number

• U.S.
Base
Price

Plastic Base

With Headrest

46513010 \$870

46513011 \$870

Assembled



• Style
Number

• U.S.
Base
Price

Ready to Assemble (Cartoned)



• Style
Number

• U.S.
Base
Price

Aluminum Base

Without Headrest

46523000 \$820

46523001 \$820

Assembled



• Style
Number

• U.S.
Base
Price

Ready to Assemble (Cartoned)



• Style
Number

• U.S.
Base
Price

Aluminum Base

With Headrest

46523010 \$970

46523011 \$970

US 
For **164** U.S., multiply all **162** U.S. prices by 1.03.
Multiply **164** U.S. by 1.2 for **138** Canadian price.
► See page 1 for details.

Think 465 Series Work Chairs

Armless

3D Knit with Sewn Upholstery on Seat



Standard Includes		Required to Specify
<ul style="list-style-type: none"> ▶ Need help? Product details, page 70 	<ul style="list-style-type: none"> • 5" pneumatic seat-height adjustment (16"-21") • Your Preference™ control • Seat edge angle • Frame, seat shell, and five-arm base • 3" seat depth adjustment • 3D Knit on back • Sewn upholstery design on seat: fabric price group 1 • 2½"-diameter, hard-composition, dual-wheel casters: black 	<ol style="list-style-type: none"> 1 Style number 2 Plastic color for frame, seat shell, and base 3 3D Knit color for back 4 Fabric color number for upholstery on seat 5 Options, if selected (see below) <ul style="list-style-type: none"> ▶ See <i>Surface Materials</i>, page 248.

Options	U.S. Price	Required to Specify
Surface Materials	Upholstery	
	<ul style="list-style-type: none"> • Fabric price group 1 • Fabric price group 2 • Fabric price group 3 • Fabric price group 4 • Fabric price group 5 • Fabric price group 6 • Fabric price group 7 • Fabric price group 8 • Fabric price group 9 • Fabric price group 10 • Steelcase leather upholstery • Customer's Own Material (COM), Customer's Own Vinyl (COV), or Customer's Own Leather (COL) • Fire Code Seating (FCS) • Soil-retardant treatment applied to upholstery fabric 	<ul style="list-style-type: none"> No cost +\$ 10 +\$ 20 +\$ 28 +\$ 35 +\$ 43 +\$ 50 +\$ 63 +\$ 78 +\$ 88 +\$140 No cost +\$ 55 +\$ 20
		<ul style="list-style-type: none"> Specify fabric color number. Specify fabric color number. Specify fabric color number. Specify fabric color number. Specify fabric color number. Specify fabric color number. Specify fabric color number. Specify fabric color number. Specify fabric color number. Specify fabric color number. Specify fabric color number. Specify leather color number. ▶ See <i>Surface Materials Reference Manual</i>.
		<ul style="list-style-type: none"> Add suffix F to the style number. Specify <i>with soil-retardant treatment</i>.
Seat Height	<ul style="list-style-type: none"> • 4" pneumatic seat-height adjustment (15"-19") 	<ul style="list-style-type: none"> No cost
		<ul style="list-style-type: none"> Specify <i>with 4" pneumatic seat-height adjustment</i>.
Lumbar Height	<ul style="list-style-type: none"> • 5" travel for additional lumbar support 	<ul style="list-style-type: none"> +\$ 50
		<ul style="list-style-type: none"> Specify <i>with adjustable lumbar height</i>.
Casters	<ul style="list-style-type: none"> • Soft, dual-wheel casters for use on hard floors 	<ul style="list-style-type: none"> +\$ 18
		<ul style="list-style-type: none"> Specify <i>with soft casters</i>.

Tip: Fire Code Seating (FCS) option is available with certain upholstery fabric choices only.
▶ Pages 254-255

Specification Information

Assembled



• Style Number
• U.S. Base Price

Ready to Assemble (Cartoned)



• Style Number
• U.S. Base Price

Plastic Base

Without Headrest

46512000 \$750 46512001 \$750

▶ Specification Information continued on next page

▶ Detailed dimensions, page 74



For 164 U.S., multiply all 162 U.S. prices by 1.03. Multiply 164 U.S. by 1.2 for 138 Canadian price.
▶ See page 1 for details.

► Specification Information continued from previous page

Specification Information

Assembled



• Style
Number

• U.S.
Base
Price

Ready to Assemble (Cartoned)



• Style
Number

• U.S.
Base
Price

Plastic Base

With Headrest

46512010 \$ 900

46512011 \$ 900

Assembled



• Style
Number

• U.S.
Base
Price

Ready to Assemble (Cartoned)



• Style
Number

• U.S.
Base
Price

Aluminum Base

Without Headrest

46522000 \$ 850

46522001 \$ 850

Assembled



• Style
Number

• U.S.
Base
Price

Ready to Assemble (Cartoned)



• Style
Number

• U.S.
Base
Price

Aluminum Base

With Headrest

46522010 \$1000

46522011 \$1000

US 
For **164** U.S., multiply all
162 U.S. prices by 1.03.
Multiply **164** U.S. by 1.2 for
138 Canadian price.
► See page 1 for details.

Think 465 Series Work Chairs

Armless
Standard Upholstery



Tip: Fire Code Seating (FCS) option is available with certain upholstery fabric choices only.
▶ Pages 254–255

Standard Includes		Required to Specify
▶ Need help? Product details, page 70	<ul style="list-style-type: none"> 5" pneumatic seat-height adjustment (16"–21") Your Preference™ control Seat edge angle Frame, seat shell, and five-arm base 3" seat depth adjustment Standard upholstery design: fabric price group 1 2½"-diameter, hard-composition, dual-wheel casters: black 	<ol style="list-style-type: none"> Style number Plastic color for frame, seat shell, and base Fabric color number for upholstery on seat and back Options, if selected (see below) <p>▶ See <i>Surface Materials</i>, page 248.</p>

Options	U.S. Price	Required to Specify	
Surface Materials <ul style="list-style-type: none"> Fabric price group 1 Fabric price group 2 Fabric price group 3 Fabric price group 4 Fabric price group 5 Fabric price group 6 Fabric price group 7 Fabric price group 8 Fabric price group 9 Fabric price group 10 Customer's Own Material (COM) Fire Code Seating (FCS) Soil-retardant treatment applied to upholstery fabric 	<ul style="list-style-type: none"> No cost +\$ 20 +\$ 40 +\$ 55 +\$ 70 +\$ 85 +\$100 +\$125 +\$155 +\$175 No cost +\$ 55 +\$ 20 	<ul style="list-style-type: none"> Specify fabric color number. Specify fabric color number. Specify fabric color number. Specify fabric color number. Specify fabric color number. Specify fabric color number. Specify fabric color number. Specify fabric color number. Specify fabric color number. Specify fabric color number. Specify fabric color number. ▶ See <i>Surface Materials Reference Manual</i>. Add suffix F to the style number. Specify with soil-retardant treatment. 	
Seat Height	<ul style="list-style-type: none"> 4" pneumatic seat-height adjustment (15"–19") 	<ul style="list-style-type: none"> No cost <p>Specify with 4" pneumatic seat-height adjustment.</p>	
Lumbar Height	<ul style="list-style-type: none"> 5" travel for additional lumbar support 	+\$ 50	Specify with adjustable lumbar height.
Casters	<ul style="list-style-type: none"> Soft, dual-wheel casters for use on hard floors 	+\$ 18	Specify with soft casters.

Specification Information

Assembled		Ready to Assemble (Cartoned)	
• Style Number	• U.S. Base Price	• Style Number	• U.S. Base Price

Plastic Base

Without Headrest

46510000	\$680	46510001	\$680
----------	-------	----------	-------

▶ Detailed dimensions, page 74

▶ Specification Information continued on next page

US

For **164** U.S., multiply all **162** U.S. prices by 1.03. Multiply **164** U.S. by 1.2 for **138** Canadian price.
▶ See page 1 for details.

► Specification Information continued from previous page

Specification Information

Assembled



• Style
Number

• U.S.
Base
Price

Ready to Assemble (Cartoned)



• Style
Number

• U.S.
Base
Price

Plastic Base

With Headrest

46510010 \$830

46510011 \$830

Assembled



• Style
Number

• U.S.
Base
Price

Ready to Assemble (Cartoned)



• Style
Number

• U.S.
Base
Price

Aluminum Base

Without Headrest

46520000 \$780

46520001 \$780

Assembled



• Style
Number

• U.S.
Base
Price

Ready to Assemble (Cartoned)



• Style
Number

• U.S.
Base
Price

Aluminum Base

With Headrest

46520010 \$930

46520011 \$930

US 

For **164** U.S., multiply all **162** U.S. prices by 1.03.
Multiply **164** U.S. by 1.2 for **138** Canadian price.
► See page 1 for details.

Think 465 Series Work Chairs

Armless
Sewn Upholstery



Tip: Always add suffixes in alphabetical order when specifying options to Think seating.

*Tip: Leather, COL, vinyl, and COV materials require an additional stitch detail across the lumbar region of the back cushion. Specify with **S** suffix.*

Tip: Fire Code Seating (FCS) option is available with certain upholstery fabric choices only.
▶ Pages 254–255

Standard Includes		Required to Specify
▶ Need help? Product details, page 70	<ul style="list-style-type: none"> • 5" pneumatic seat-height adjustment (16"–21") • Your Preference™ control • Seat edge angle • Frame, seat shell, and five-arm base • 3" seat depth adjustment • Sewn upholstery design: fabric price group 1 • 2½"-diameter, hard-composition, dual-wheel casters: black 	<ol style="list-style-type: none"> 1 Style number 2 Plastic color for frame, seat shell, outer back, and base 3 Fabric color number for upholstery on seat and back 4 Options, if selected (see below) <p>▶ See <i>Surface Materials</i>, page 248.</p>

Options	U.S. Price	Required to Specify	
Surface Materials <ul style="list-style-type: none"> • Fabric price group 1 • Fabric price group 2 • Fabric price group 3 • Fabric price group 4 • Fabric price group 5 • Fabric price group 6 • Fabric price group 7 • Fabric price group 8 • Fabric price group 9 • Fabric price group 10 • Steelcase leather upholstery • Steelcase vinyl • Customer's Own Material (COM) • Customer's Own Vinyl (COV) • Customer's Own Leather (COL) • Fire Code Seating (FCS) • Soil-retardant treatment applied to upholstery fabric 	No cost +\$ 20 +\$ 40 +\$ 55 +\$ 70 +\$ 85 +\$100 +\$125 +\$155 +\$175 +\$275 No cost No cost No cost +\$ 55 +\$ 20	Specify fabric color number. Specify fabric color number. Specify fabric color number. Specify fabric color number. Specify fabric color number. Specify fabric color number. Specify fabric color number. Specify fabric color number. Specify fabric color number. Specify fabric color number. Add suffix S to the style number and specify leather color number. Add suffix S to the style number and specify vinyl color number. ▶ See <i>Surface Materials Reference Manual</i> . Add suffix S to the style number and specify vinyl color number. Add suffix S to the style number and specify leather color number. Add suffix F to the style number. Specify <i>with soil-retardant treatment</i> .	
Seat Height	<ul style="list-style-type: none"> • 4" pneumatic seat-height adjustment (15"–19") 	No cost	Specify <i>with 4" pneumatic seat-height adjustment</i> .
Lumbar Height	<ul style="list-style-type: none"> • 5" travel for additional lumbar support 	+\$ 50	Specify <i>with adjustable lumbar height</i> .
Casters	<ul style="list-style-type: none"> • Soft, dual-wheel casters for use on hard floors 	+\$ 18	Specify <i>with soft casters</i> .

Specification Information

Assembled



• Style Number
• U.S. Base Price

Ready to Assemble (Cartoned)



• Style Number
• U.S. Base Price

▶ Detailed dimensions, page 74

Plastic Base

Without Headrest

46511000 \$740 46511001 \$740

▶ Specification Information continued on next page

US

For **164** U.S., multiply all **162** U.S. prices by 1.03.
Multiply **164** U.S. by 1.2 for **138** Canadian price.
▶ See page 1 for details.

► Specification Information continued from previous page

Specification Information

Assembled



• Style
Number

• U.S.
Base
Price

Ready to Assemble (Cartoned)



• Style
Number

• U.S.
Base
Price

Plastic Base

With Headrest

46511010 \$890

46511011 \$890

Assembled



• Style
Number

• U.S.
Base
Price

Ready to Assemble (Cartoned)



• Style
Number

• U.S.
Base
Price

Aluminum Base

Without Headrest

46521000 \$840

46521001 \$840

Assembled



• Style
Number

• U.S.
Base
Price

Ready to Assemble (Cartoned)



• Style
Number

• U.S.
Base
Price

Aluminum Base

With Headrest

46521010 \$990

46521011 \$990

US 
For **164** U.S., multiply all
162 U.S. prices by 1.03.
Multiply **164** U.S. by 1.2 for
138 Canadian price.
► See page 1 for details.



Understanding and Specifying Drive 461 Series Work Chairs

Understanding Drive 461 Series

Details	96
Dimensions	100

Specifying Drive 461 Series

Work Chairs	102
-------------	-----

Work Chairs

Highly adjustable task seating offers maximum personalization for people who sit most of the day performing repetitive tasks. By making a series of simple adjustments, you can customize the chair to your body, preferences, and tasks. These chairs provide continuous, stable, task-oriented comfort, and can be quickly adjusted to support you in upright, forward, and reclining work postures.

- Leap 462 Series
- Leap 464 Series WorkLounge
- Siento 499 Series
- Criterion 453 Series
- Think 465 Series
- Drive 461 Series
- Jersey Series
- Sensor 458 Series

Adjustability Features

▶ See page 11 for a comparison to other chairs.

Drive 461 Series

Mechanisms

Synchro-tilt	●
--------------	---

Seat Adjustments

Pneumatic height	●
------------------	---

Seat angle	●
------------	---

Seat depth	●
------------	---

Back Adjustments

Lumbar height	●
---------------	---

Back tension	●
--------------	---

Upright back lock	●
-------------------	---

Arm Adjustments

Arm height	●
------------	---

Arm width	●
-----------	---

Arm pivot	●
-----------	---

Drive 461 Series

Drive is high-performance seating for value-driven customers. Intuitive controls, high-comfort ratings, a versatile statement of line, and a wide range of adjustments make it a great solution for anywhere in the office.

Outer back and outer seat is plastic. Fully upholstered outer back is an option.

Lumbar adjusts up and down within a 4" range to help ensure healthful back posture.

Arm height adjusts independently within a 4" range to help relieve upper back and shoulder fatigue.

Face plate is plastic and will match base color.

Upright back lock allows user to lock the back in a full upright position or release it for full-tilt motion.

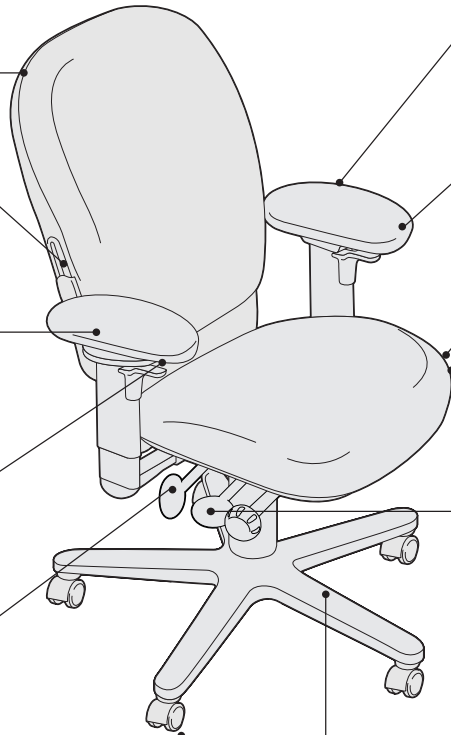

Arm width adjusts within a 3" range for each arm to provide forearm support in neutral position for 5th to 95th percentile users.

Arm caps can pivot independently to accommodate user preferences.

Seat depth adjusts within a 3" range and is an option on all models. Adjustment paddle is located on left side of chair.

Seat angle adjusts forward, upright, and reclined to suit user.

Seat height adjusts within a 5" range with a pneumatic adjustment mechanism.

Five-arm base is steel with plastic cap.

Casters have hard, dual-wheels that roll smoothly on carpets. Soft, dual-wheel casters are available for use on hard floors or chair mats.

Product Details



Full-back height is available with and without arms.

Drive offers multiple arm options.

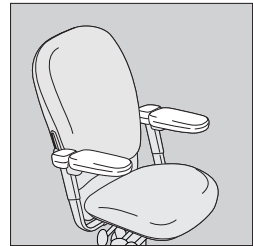

Height- and width-adjustable T-arms

- Height- and width-adjustable T-arms are standard on all chairs with arms.



Independent height-, width-, and pivot-adjustable arms

- Telescoping arms with height, width, and pivot adjustability are an option.

Adjustment Features

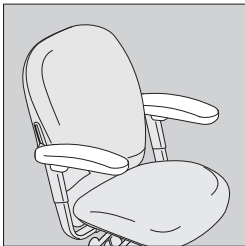

Height-adjustable T-arms

- Height-adjustable T-arms are an option.

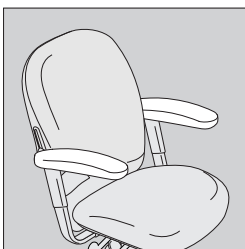

Fixed T-Arms

- Fixed T-Arms are an option.

Seat Adjustments

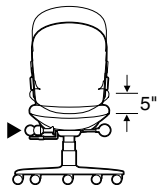

Seat height adjusts pneumatically.

To raise, lift your weight off the seat and pull lever up. To lower chair, remain seated and pull lever up.

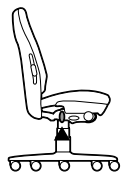

Seat angle adjusts

by pulling paddle and shifting your weight to alter seat angle. Release paddle to lock.

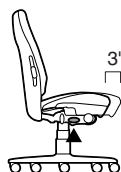

Seat depth adjustment.

Lift paddle under left side of seat. Slide seat forward or backward. Release paddle.

Back Adjustments

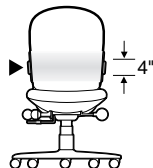

Lumbar adjustment.

Lean forward to slide handle up or down with both hands to desired position.

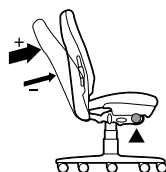

Back tension adjustment.

Turn knob forward to increase tension, backwards to decrease.



Upright back lock.

To release, lean forward and pull toward back. To lock, lean forward and push toward front.

Arm Adjustments

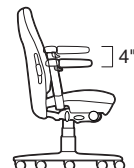

Arm height.

Lift trigger, raise or lower to desired height.

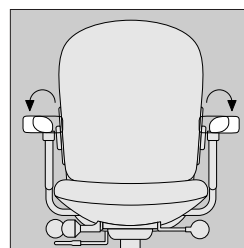

Arm width on standard T-arm.

Grasp arm caps, flip them over.

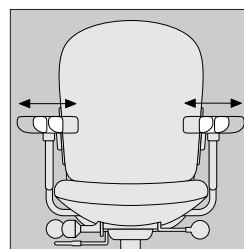

Arm width on rounded telescoping height, width, and pivot arm.

Grasp arm caps and move in or out. Arm will stay where positioned.

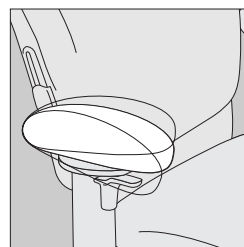

Arms pivot independently.

Grasp arm and push from front to left or right.

Surface Materials

► See surface materials on page 248 for specific availability or refer to the *Surface Materials Reference Manual* for further information.

Upholstery

- Fabric
- Fabric with soil-retardant treatment (option)
- Leather

Hard components

(base, arms, plastic arm caps, outer back, outer seat, and face plate)

- Monochromatic color from list of seating plastic color numbers will apply to all hard components.

Outer back and outer seat

- Plastic color to match color of other "hard components"
- Fully upholstered outer back

Arms

- Plastic color arm caps to match the plastic color of the other "hard components"

All Steelcase seating with standard upholstery fabrics

complies with requirements of the BIFMA First Generation Upholstered Furniture Flammability Standard, as well as the State of California Technical Bulletin 117. All standard seating is labeled to be in compliance with California TB117.

Programs & Services

▶ See the *Surface Materials Reference Manual* for further detail about programs and services offered for seating.

The Customer's Own Material (COM) Program

offers the opportunity for customers to select fabrics that are not offered through the standard Steelcase surface materials program for use on Steelcase products. Through the COM program, Steelcase will test your materials for application on Steelcase products. Once approved, you can place your order. Steelcase will facilitate the entire ordering process and give you a production schedule. Steelcase will order the COM fabric directly from the textile manufacturer. For up-to-date information regarding fabric test results for all COM fabrics and details regarding yardage requirements for most Seating lines, visit the COM Web site. To locate the COM Web site:

- Visit www.steelcase.com
- Click on "Knowledge & Design"
- Select "Customer's Own Material"

Soil retardants are treatments that provide long-term soil and stain resistance to a fabric without affecting the shade or the integrity of the fabric. The following Steelcase Textiles are available pre-treated with soil retardant. (You do not need to select the soil-retardant option for these fabrics and incur the upcharge.)

- Jacks
- Link
- Regis
- Roulette
- Skittles
- Spyder

Soil-retardant treatment is available on all other seating fabrics at an additional upcharge per seating unit. To order this option, please select "Soil-Retardant Treatment" under "Optional Accessories."

For soil-retardant treatment on COMs, please select "Soil-Retardant Treatment" under "Optional Accessories." Minimums or additional yardage may be required. Please contact the vendor directly for specific information.

Extended lead times may be necessary for this service.

Contact your Steelcase Solutions Fulfillment Team Representative at 1.888.STEELCASE (1.888.783.3522).

Fire Codes

▶ See pages 254–255 for upholstery fabrics available for use with FCS modification.

Steelcase offers Fire Code Seating modification (FCS) on nearly all seating models. The most rigorous fire codes in the nation have been developed in California, and the Steelcase FCS modification is designed to meet those codes. Fire Code Seating (FCS) indicates that a product is constructed to meet the strict fire code requirements of high public occupancy areas such as theaters, meeting rooms, and lobbies. The FCS standards will meet both the State of California Home Furnishing Technical Bulletin 133 (Cal TB 133) and Boston Fire Code (BFC). Boston adopted the California Home Furnishing Technical Bulletin TB 133 test standard in 1992.

Local codes may have special requirements for upholstery.

Dimensions

▶ Page 100

Resources

Printed Materials

- ▶ Drive Brochure (04-0011869)
- ▶ Seating Overview (06-0000890)
- ▶ Drive User Guide (S11264)

Computer Tools

- ▶ Interactive User Guide available on www.steelcase.com
- ▶ Electronic User Disk (S10615)

Dimensions

Drive 461 Series

Features	Overall Depth	Width	Height	Fixed Seat Depth	Adjustable Seat Depth	Seat Width	Seat Height from Floor	Back Width	Back Height from Seat
----------	---------------	-------	--------	------------------	-----------------------	------------	------------------------	------------	-----------------------

Drive 461 Series

Full-Back Work Chairs

Arms	27 ³ / ₈ "	26"	37 ¹ / ₂ "-42 ¹ / ₂ "	16 ³ / ₄ "	16"-19"	20"	15 ¹ / ₂ "-20 ¹ / ₂ "	18 ¹ / ₂ "	23 ¹ / ₂ "
Without Arms	27 ³ / ₈ "	19 ¹ / ₂ "	37 ¹ / ₂ "-42 ¹ / ₂ "	16 ³ / ₄ "	16"-19"	20"	15 ¹ / ₂ "-20 ¹ / ₂ "	18 ¹ / ₂ "	23 ¹ / ₂ "

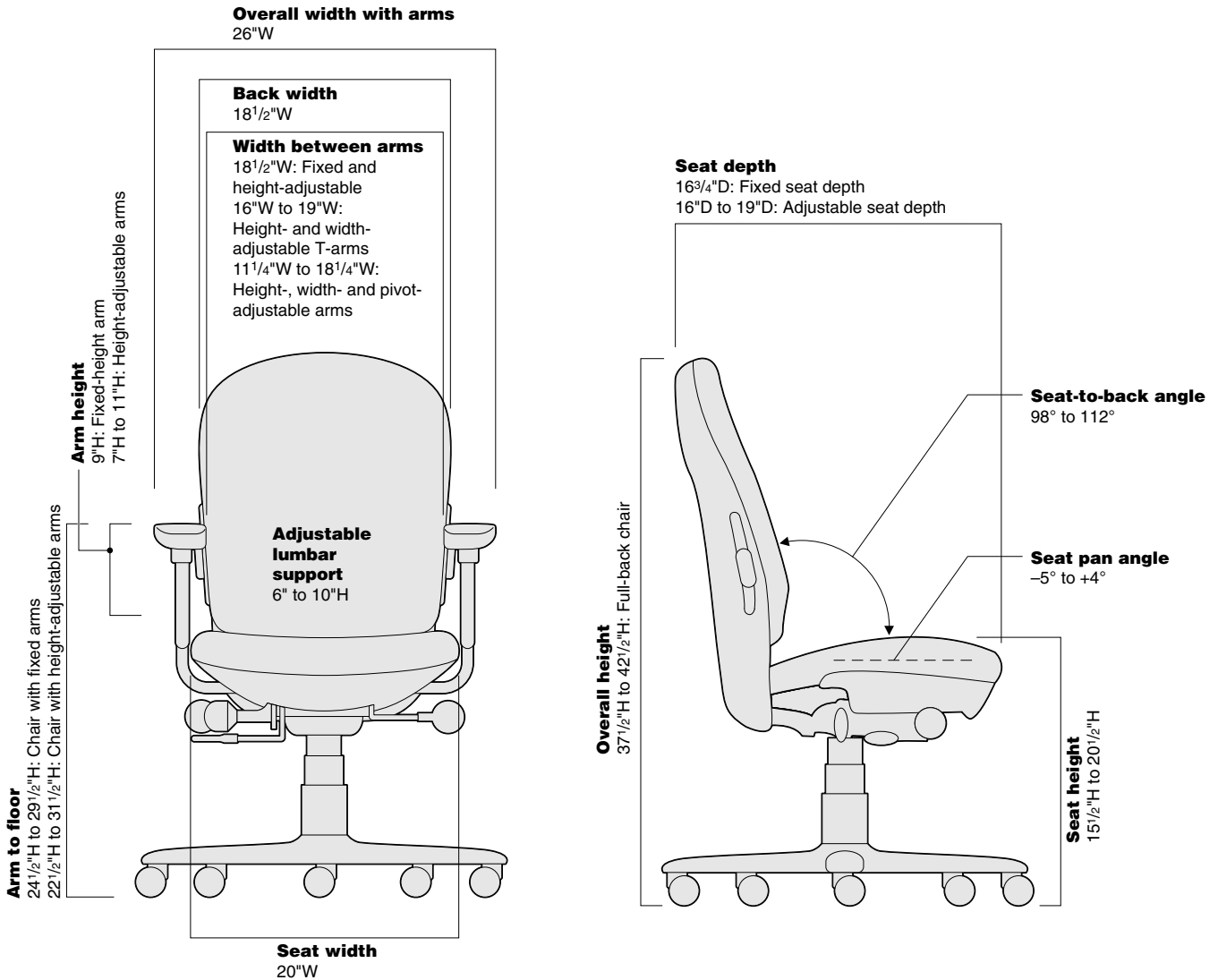

• Back Lumbar Height	• Arm to Floor	• Adjustable Arm Height from Seat	• Fixed Arm Height from Seat	• Width Between Fixed and Height-Adjustable Arms	• Width Between Height-Adjustable T-Arms	• Width Between Height-, Width- and Pivot-Adjustable Arm	• Seat Pan Angle	• Angle Between Seat and Back
Full-Back Work Chairs								
6"-10"	22"-33"	7"-11"	9"	18½"	16"-19"	11¼"-18¼"	-5°-+4°	98°-112°
6"-10"	N.A.	N.A.	N.A.	N.A.	N.A.	N.A.	-5°-+4°	98°-112°

Drive 461 Series Work Chairs



	Standard Includes	Required to Specify
▶ Need help? Product details, page 96	<ul style="list-style-type: none"> • Synchro-tilt mechanism • Upright back lock • Lumbar adjustment • 5" seat height range • Pneumatic height adjustment • Height- and width-adjustable T-Arms, if selected: plastic color to match base • Outer back and outer seat: plastic • Upholstery: fabric price group 1 • Five-arm base: plastic color • 2½"-diameter, hard composition, dual-wheel casters: plastic color to match base 	<ol style="list-style-type: none"> 1 Style number 2 Plastic color number for base, outer back, outer seat, arms, and casters 3 Fabric color number for upholstery 4 Options, if selected (see below) <p>▶ See <i>Surface Materials</i>, page 248.</p>

	Options	U.S. Price	Required to Specify
Surface Materials	Upholstery		
	• Fabric price group 1	No cost	Specify fabric color number.
	• Fabric price group 2	+\$ 20	Specify fabric color number.
	• Fabric price group 3	+\$ 40	Specify fabric color number.
	• Fabric price group 4	+\$ 55	Specify fabric color number.
	• Fabric price group 5	+\$ 70	Specify fabric color number.
	• Fabric price group 6	+\$ 85	Specify fabric color number.
	• Fabric price group 7	+\$100	Specify fabric color number.
	• Fabric price group 8	+\$125	Specify fabric color number.
	• Fabric price group 9	+\$155	Specify fabric color number.
• Fabric price group 10	+\$175	Specify fabric color number.	
• Customer's Own Material (COM)	+\$ 30	▶ See <i>Surface Materials Reference Manual</i> to specify.	
• Steelcase leather upholstery	+\$552	Add suffix S to the style number and specify leather color number for upholstery.	
• Customer's Own Leather (COL)	+\$321	Add suffix S to the style number. ▶ See <i>Surface Materials Reference Manual</i> to specify.	
• Fire Code Seating (FCS)	+\$ 55	Add suffix F to style number.	
• Soil-retardant treatment applied to upholstery fabric	+\$ 20	Specify <i>with soil-retardant treatment</i> .	
	Fully upholstered		
	• Fabric fully upholstered outer back	+\$135	Add suffix U to style number.
	• Steelcase leather fully upholstered outer back	+\$959	Add suffix SU to the style number and specify leather color number.
	• Customer's Own Leather (COL)	+\$499	Add suffix SU to the style number. ▶ See <i>Surface Materials Reference Manual</i> to specify.
Rounded Arm Caps	• Independent height-, width-, and pivot-adjustable	+\$ 33	Specify <i>with height-, width-, and pivot-adjustable arms</i> .
T-Arms	• Independent height-adjustable	-\$ 66	Specify <i>with height-adjustable T-arms</i> .
	• Fixed height	-\$102	Specify <i>with fixed T-arms</i> .
Casters	• Soft, dual-wheel casters for use on hard floors (2½")	+\$ 18	Specify <i>with soft casters</i> .

Tip: Always add suffixes in alphabetical order when specifying options to Drive seating.

Tip: Fire Code Seating (FCS) option is available with certain upholstery fabric choices only.

▶ Pages 254–255

▶ Detailed dimensions, page 100

US 

For **164** U.S., multiply all **162** U.S. prices by 1.03.
Multiply **164** U.S. by 1.2 for **138** Canadian price.
▶ See page 1 for details.

Specification Information

Arms with Soft Arm Caps



• Style
• Number

• U.S.
• Base
• Price

Without Arms



• Style
• Number

• U.S.
• Base
• Price

Full-Back Work Chairs

Back Lock, Seat Angle, Seat Depth

4611411	\$955	4611401	\$766
----------------	-------	----------------	-------

Back Lock, Seat Depth

4611311	\$901	4611301	\$712
----------------	-------	----------------	-------

Back Lock

4611111	\$845	4611101	\$656
----------------	-------	----------------	-------

US 

For **164** U.S., multiply all **162** U.S. prices by 1.03.
Multiply **164** U.S. by 1.2 for **138** Canadian price.
▶ See page 1 for details.



Understanding and Specifying Jersey Series Work Chair

Understanding Jersey Series

Details	106
Dimensions	110

Specifying Jersey Series

Value Package Work Chair	112
Work Chairs	113
Multi-Use Chairs	115

Work Chairs

Highly adjustable task seating offers maximum personalization for people who sit most of the day performing repetitive tasks. By making a series of simple adjustments, you can customize the chair to your body, preferences, and tasks. These chairs provide continuous, stable, task-oriented comfort, and can be quickly adjusted to support you in upright, forward, and reclining work postures.

- Leap 462 Series
- Leap 464 Series WorkLounge
- Siento 499 Series
- Criterion 453 Series
- Think 465 Series
- Drive 461 Series
- Jersey Series
- Sensor 458 Series

Adjustability Features

▶ See page 11 for a comparison to other chairs.

Jersey Series

Mechanisms

Synchro-tilt	●
--------------	---

Seat Adjustments

Pneumatic height	●
------------------	---

Seat angle	●
------------	---

Seat depth	●
------------	---

Back Adjustments

Back tension	●
--------------	---

Upright back lock	●
-------------------	---

Arm Adjustments

Arm height	●
------------	---

Arm width	●
-----------	---

Arm pivot	●
-----------	---

Jersey Series

Jersey features a double mesh back in a unique ergonomic "S" shape to conform to each user for comfort and support.

Arm height adjusts independently within a 4" range to help relieve upper back and shoulder fatigue.

Arm width adjusts within a 3" range for each arm to provide forearm support in a neutral position.

Arm caps can pivot independently to accommodate user preferences.

Seat height adjusts 4½", from 16" to 20½", with a pneumatic adjustment mechanism.

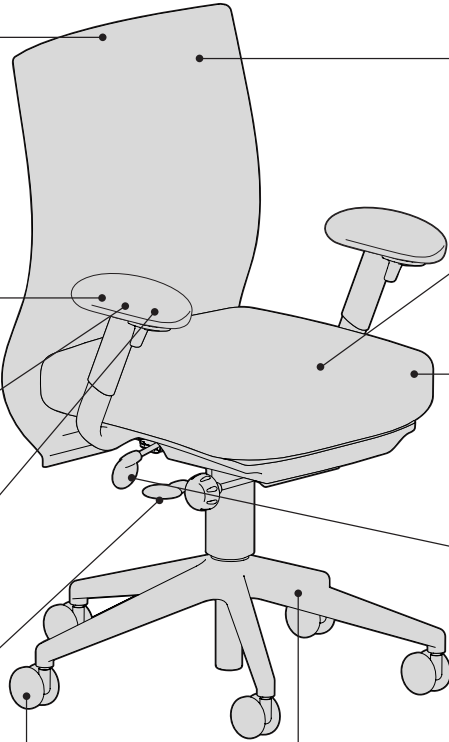

Mesh back is available in 9 colors and is standard on all models. Jersey pullover is optional and available in 6 colors.

Seat depth adjusts within a 3" range and is an option on all models.

Seat angle adjusts forward, upright, and reclined to suit user.

Upright back lock allows user to lock the back in a full upright position or release it for full-tilt motion.

Five-arm base is plastic on 6205 Black frame models. Base is aluminum on 4799 Platinum models.

Casters have hard, dual-wheels that roll smoothly on carpets. Soft, dual-wheel casters are available for use on hard floors or chair mats.

Product Details



Jersey work chairs are available armless, with fixed arms, with height and maintenance width-adjustable arms, and with height-, width-, and pivot-adjustable arms.

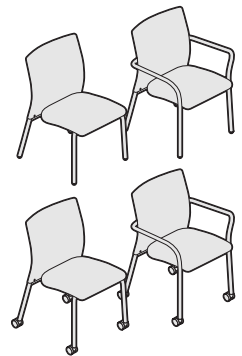

Multi-use chairs are available with or without arms and with or without casters.

Arm cap styles depend on the arm adjustment selected.

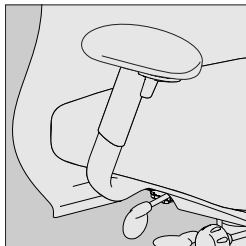

Arm cap on height-, width-, and pivot-adjustable arms.

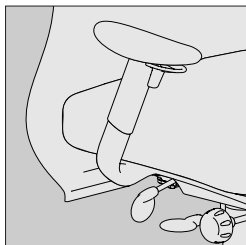

Arm cap on fixed and height and maintenance-width-adjustable arms.

Stackability for the Jersey guest chair is four high on the floor. Models with arms are 24¹/₄"W x 28¹/₂"D x 42¹/₂"H. Models without arms are 20⁵/₈"W x 28¹/₂"D x 42¹/₂"H. If stacking dimensions are intended for an enclosure, add 2" to the width and depth, and 1" to the height for clearance.

Adjustment Features

Seat Adjustments

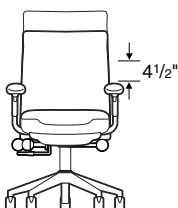

Seat height adjusts pneumatically.

To raise chair, lift body weight up, and pull lever up. To lower chair, remain seated and pull lever up.



Seat angle adjustment.

Pull lever back and hold, shift seat to desired angle, and release lever to lock.

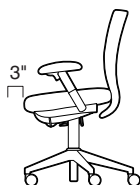

Seat depth adjustment.

Pull lever forward and hold, shift seat forward or back, and release lever to lock.

Back Adjustments



Back tension adjustment.

To decrease tension, turn counterclockwise. To increase tension, turn clockwise.



Upright back lock.

To release, lean forward and pull toward back. To lock, lean forward and push toward front.

Arm Adjustments



Arm height.

Pull trigger up and hold, pull arm up or push down, and release trigger to lock

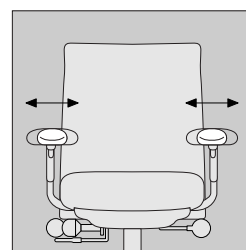

Arm width on rounded telescoping height, width, and pivot arm.

Grasp arm caps and move in or out. Arm will stay where positioned.

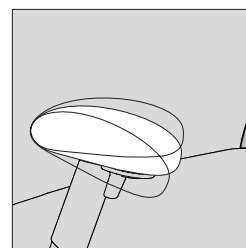

Arms pivot independently.

Grasp arm and push from front to left or right.

Maintenance arm width adjustment.

Loosen and remove screws, slide arm bracket in. Replace and tighten screws.

Surface Materials

► See surface materials on page 248 for specific availability or refer to the *Surface Materials Reference Manual* for further information.

Upholstery

- Fabric or leather on seat
- Mesh on back standard
- Jersey pullover on back optional

Hard components

- (base, arms, plastic arm caps, outer seat)
- Black

Platinum frame

(base and arm uprights) available as an option

Arms

- Black

All Steelcase seating with standard upholstery fabrics

complies with requirements of the BIFMA First Generation Voluntary Upholstered Furniture Flammability Standard, as well as the State of California Technical Bulletin 117. All standard seating is labeled to be in compliance with California TB117.

Programs & Services

▶ See the *Surface Materials Reference Manual* for further detail about programs and services offered for seating.

The Customer's Own Material (COM) Program

offers the opportunity for customers to select fabrics that are not offered through the standard Steelcase surface materials program for use on Steelcase products. Through the COM program, Steelcase will test your materials for application on Steelcase products. Once approved, you can place your order. Steelcase will facilitate the entire ordering process and give you a production schedule. Steelcase will order the COM fabric directly from the textile manufacturer. For up-to-date information regarding fabric test results for all COM fabrics and details regarding yardage requirements for most Seating lines, visit the COM Web site. To locate the COM Web site:

- Visit www.steelcase.com
- Click on "Knowledge & Design"
- Select "Customer's Own Material"

Dimensions

▶ Page 110

Resources

Printed Materials

- ▶ Jersey Brochure (04-0000161)
- ▶ Seating Overview (06-0000890)

Computer Tools

- ▶ User Guide available on www.steelcase.com

Shipping

Jersey chairs are cartoned assembled only. Uncartoned shipments are not available.

Dimensions

Jersey Series

Features	Overall Depth	Width	Height	Functional Seat Depth	Seat Width	Seat Height from Floor	Back Width	Back Height from Seat
----------	---------------	-------	--------	-----------------------	------------	------------------------	------------	-----------------------

Jersey Series

Work Chairs

Pneumatic	25"	26 1/4"	35 1/2"–40"	17"	20"	16"–20 1/2"	20"	18"
-----------	-----	---------	-------------	-----	-----	-------------	-----	-----

Multi-Use Chairs

4-Leg with Arms	24"	24"	34"	17"	17 1/2"	17 1/2"	19"	15 1/2"
4-Leg Armless	24"	17 1/2"	34"	17"	17 1/2"	17 1/2"	19"	15 1/2"

*Models with seat depth measures 16 3/4"–20"

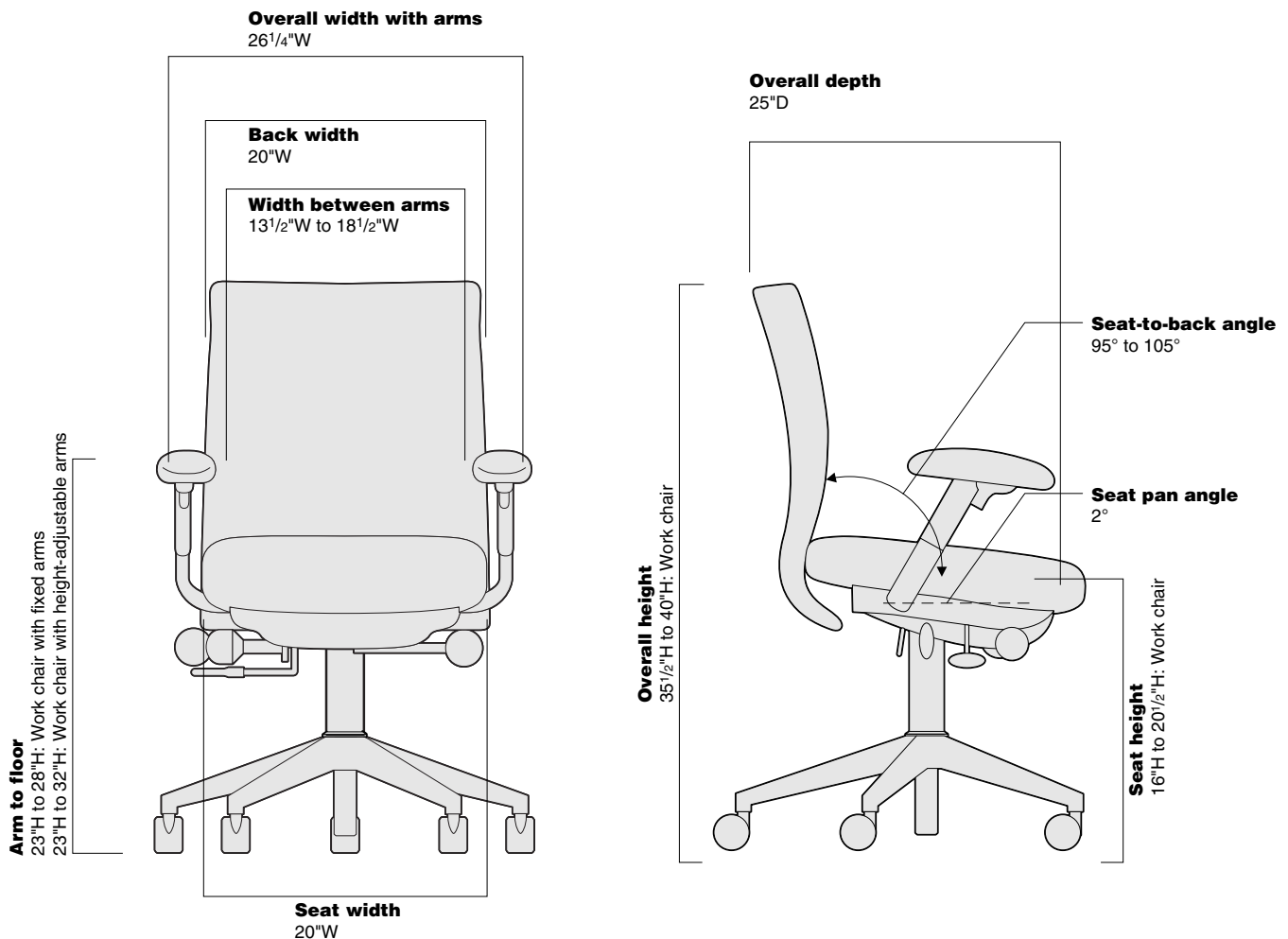

• Width • Between • Arms	• Arm to • Floor • Fixed • Arm	• Arm to • Floor • Height Adj • Arm	• Arm • Height • from Seat • Fixed Arm	• Arm • Height • from Seat • Adj-Height • Arm	• Seat • Pan • Angle	• Angle • Between • Seat and • Back
--------------------------------	---	--	---	---	----------------------------	--

Work Chairs

13½"-18½"	23"-28"	23"-32"	9"	7"-11"	2°	95°-105°
-----------	---------	---------	----	--------	----	----------

Multi-Use Chairs

21⅝"	25½"	N.A.	7½"	N.A.	2°	N.A.
N.A.	N.A.	N.A.	N.A.	N.A.	N.A.	N.A.

Jersey Series Value Package Work Chair

Black Mesh on Back with Buzz2 Fabric on Seat
Black Plastic Finish on Frame



Tip: This value package allows you to obtain the pre-selected features at a lower price than if specifying as a standard model number.

Tip: Options or substitutions are not available on this value package.

Standard Includes		Required to Specify
<ul style="list-style-type: none"> ▶ Need help? Product details, page 106 	<ul style="list-style-type: none"> • Deluxe synchro-tilt mechanism: provides seat depth and seat angle • Pneumatic seat-height adjustment • Upright back lock • Tilt tension • Back: T084 Black mesh • Seat: Buzz2 fabric • Height-, width-, and pivot-adjustable arms • Frame: black plastic • Hard dual-wheel casters: black 	<ul style="list-style-type: none"> 1 Style number 2 Buzz2 fabric color number ▶ See <i>Surface Materials</i>, page 248.

Specification Information	
• Style Number	• U.S. Price
JERSEYV	\$783
:	:
:	:

▶ Detailed dimensions, page 110

US 

For **164** U.S., multiply all **162** U.S. prices by 1.03.
Multiply **164** U.S. by 1.2 for **138** Canadian price.
▶ See page 1 for details.

Work Chair, Fabric



Tip: Arms, if specified, will match frame color (6205 Black standard, 4799 Platinum optional).

	Standard Includes	Required to Specify
▶ Need help? Product details, page 106	<ul style="list-style-type: none"> • Synchro-tilt mechanism • Pneumatic height adjustment • Upright back lock • Tilt tension • Back: mesh • Seat: fabric • Five-arm base: reinforced black plastic • Hard dual-wheel casters: black 	<ol style="list-style-type: none"> 1 Style number 2 Mesh color number for back: <ul style="list-style-type: none"> T084 Black T085 Grey T086 White T087 Yellow T088 Orange T089 Red T090 Green T091 Blue T094 Cardinal 3 Fabric color number for seat 4 Options, if selected (see below) <ul style="list-style-type: none"> ▶ See <i>Surface Materials</i>, page 248.

	Options	U.S. Price	Required to Specify
Surface Materials	<ul style="list-style-type: none"> • 4799 Platinum frame with aluminum base 	+\$ 50	Specify with 4799 Platinum.
Fabric Seat	<ul style="list-style-type: none"> • Jersey black fabric • Buzz2 • Customer's Own Material (COM) 	No cost No cost No cost	Specify with 5011. Specify fabric color number. ▶ See <i>Surface Materials Reference Manual</i> to specify.
Jersey Pullover	<ul style="list-style-type: none"> • Stretch pullover 	+\$ 70	Specify with jersey pullover and select color number: T092 Black T095 Yellow T096 Orange T097 Red T098 Green T099 Blue
Seating Mechanism	<ul style="list-style-type: none"> • Deluxe synchro-tilt mechanism: provides seat depth and seat angle 	+\$ 71	Specify with deluxe synchro-tilt mechanism.
Fixed-Height Arms	<ul style="list-style-type: none"> • Fixed-height, maintenance width-adjustable arms 	+\$ 81	Specify with fixed-height, maintenance width-adjustable arms.
Height-Adjustable Arms	<ul style="list-style-type: none"> • Height- and maintenance width-adjustable arms 	+\$102	Specify with height- and maintenance width-adjustable arms.
Height-, Width-, and Pivot-Adjustable Arms	<ul style="list-style-type: none"> • Height-, width-, and pivot-adjustable arms 	+\$117	Specify with height-, width-, and pivot-adjustable arms.
Casters	<ul style="list-style-type: none"> • Soft dual-wheel casters for use on hard floors 	+\$ 25	Specify with soft casters.

Specification Information

Style Number	U.S. Base Price
TS38301	\$655

▶ Detailed dimensions, page 110

US **CA**

For **164** U.S., multiply all **162** U.S. prices by 1.03. Multiply **164** U.S. by 1.2 for **138** Canadian price.
▶ See page 1 for details.

Work Chair, Leather



Tip: Arms, if specified, will match frame color (6205 Black standard, 4799 Platinum optional).

Standard Includes		Required to Specify
<ul style="list-style-type: none"> ▶ Need help? Product details, page 106 	<ul style="list-style-type: none"> • Synchro-tilt mechanism • Pneumatic height adjustment • Upright back lock • Tilt tension • Back: mesh • Seat: black leather • Five-arm base: reinforced black plastic • Hard dual-wheel casters: black 	<ul style="list-style-type: none"> 1 Style number 2 Mesh color number for back: <ul style="list-style-type: none"> T084 Black T085 Grey T086 White T087 Yellow T088 Orange T089 Red T090 Green T091 Blue T094 Cardinal 3 Options, if selected (see below)

Options	U.S. Price	Required to Specify
Surface Materials <ul style="list-style-type: none"> • 4799 Platinum frame with aluminum base 	+\$ 50	Specify with 4799 Platinum.
Jersey Pullover <ul style="list-style-type: none"> • Stretch pullover 	+\$ 70	Specify with jersey pullover and select color number: <ul style="list-style-type: none"> T092 Black T095 Yellow T096 Orange T097 Red T098 Green T099 Blue
Seating Mechanism <ul style="list-style-type: none"> • Deluxe synchro-tilt mechanism: provides seat depth and seat angle 	+\$ 71	Specify with deluxe synchro-tilt mechanism.
Fixed-Height Arms <ul style="list-style-type: none"> • Fixed-height, maintenance width-adjustable arms 	+\$ 81	Specify with fixed-height, maintenance width-adjustable arms.
Height-Adjustable Arms <ul style="list-style-type: none"> • Height- and maintenance width-adjustable arms 	+\$102	Specify with height- and maintenance width-adjustable arms.
Height-, Width-, and Pivot-Adjustable Arms <ul style="list-style-type: none"> • Height-, width-, and pivot-adjustable arms 	+\$117	Specify with height-, width-, and pivot-adjustable arms.
Casters <ul style="list-style-type: none"> • Soft dual-wheel casters for use on hard floors 	+\$ 25	Specify with soft casters.

Specification Information	
• Style Number	• U.S. Base Price
TS38302	\$736

▶ Detailed dimensions, page 110

US 

For **164** U.S., multiply all **162** U.S. prices by 1.03. Multiply **164** U.S. by 1.2 for **138** Canadian price. ▶ See page 1 for details.

Jersey Series Multi-Use Chairs

Jersey Series
Multi-Use Chairs

Multi-Use Chair, Fabric, with Glides



	Standard Includes	Required to Specify
<p>► Need help? Product details, page 106</p>	<ul style="list-style-type: none"> • Back: mesh • Seat: fabric • Arms, if selected: black • Steel four-leg frame: black • Glides: black plastic • Stacks four high 	<ol style="list-style-type: none"> 1 Style number 2 Mesh color number for back: <ul style="list-style-type: none"> T084 Black T085 Grey T086 White T087 Yellow T088 Orange T089 Red T090 Green T091 Blue T094 Cardinal 3 Fabric color number for seat 4 Options, if selected (see below) <ul style="list-style-type: none"> ► See <i>Surface Materials</i>, page 248.

	Options	U.S. Price	Required to Specify
Surface Materials	<ul style="list-style-type: none"> • 4799 Platinum aluminum frame 	+\$50	Specify with 4799 Platinum.
Fabric Seat	<ul style="list-style-type: none"> • Jersey black fabric • Buzz2 • Customer's Own Material (COM) 	No cost No cost No cost	Specify with 5011. Specify fabric color number. ► See <i>Surface Materials Reference Manual</i> to specify.
Jersey Pullover	<ul style="list-style-type: none"> • Stretch pullover 	+\$70	Specify with <i>jersey pullover</i> and select color number: T092 Black T095 Yellow T096 Orange T097 Red T098 Green T099 Blue

Specification Information

Style Number	U.S. Base Price

With Arms

TS38304	\$404
----------------	-------



Without Arms

TS38305	\$374
----------------	-------



Multi-Use Chair, Leather, with Glides



Standard Includes	Required to Specify
<ul style="list-style-type: none"> ▶ Need help? Product details, page 106 • Back: mesh • Seat: black leather • Arms, if selected: black • Steel four-leg frame: black • Glides: black plastic • Stacks four high 	<ul style="list-style-type: none"> 1 Style number 2 Mesh color number for back: <ul style="list-style-type: none"> T084 Black T085 Grey T086 White T087 Yellow T088 Orange T089 Red T090 Green T091 Blue T094 Cardinal 3 Options, if selected (see below)

Options	U.S. Price	Required to Specify
Surface Materials <ul style="list-style-type: none"> • 4799 Platinum aluminum frame 	+\$50	Specify with 4799 Platinum.
Jersey Pullover <ul style="list-style-type: none"> • Stretch pullover 	+\$70	Specify with jersey pullover and select color number: <ul style="list-style-type: none"> T092 Black T095 Yellow T096 Orange T097 Red T098 Green T099 Blue

Specification Information	
• Style Number	• U.S. Base Price

With Arms

TS38306	\$485



Without Arms

TS38307	\$455



▶ Detailed dimensions, page 110

US

For **164** U.S., multiply all **162** U.S. prices by 1.03.
 Multiply **164** U.S. by 1.2 for **138** Canadian price.
 ▶ See page 1 for details.

Multi-Use Chair, Fabric, with Casters

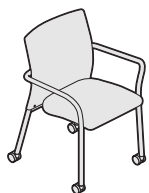

	Standard Includes	Required to Specify
▶ Need help? Product details, page 106	<ul style="list-style-type: none"> • Back: mesh • Seat: fabric • Arms, if selected: black • Steel four-leg frame: black • Hard dual-wheel casters: black • Stacks four high 	1 Style number 2 Mesh color number for back: T084 Black T085 Grey T086 White T087 Yellow T088 Orange T089 Red T090 Green T091 Blue T094 Cardinal 3 Fabric color number for seat 4 Options, if selected (see below) ▶ See <i>Surface Materials</i> , page 248.

	Options	U.S. Price	Required to Specify
Surface Materials	<ul style="list-style-type: none"> • 4799 Platinum aluminum frame 	+\$50	Specify with 4799 Platinum.
Fabric Seat	<ul style="list-style-type: none"> • Jersey black fabric • Buzz2 • Customer's Own Material (COM) 	No cost No cost No cost	Specify with 5011. Specify fabric color number. ▶ See <i>Surface Materials Reference Manual</i> to specify.
Jersey Pullover	<ul style="list-style-type: none"> • Stretch pullover 	+\$70	Specify with jersey pullover and select color number: T092 Black T095 Yellow T096 Orange T097 Red T098 Green T099 Blue
Casters	<ul style="list-style-type: none"> • Soft dual-wheel casters for use on hard floors 	+\$25	Specify with soft casters.

Specification Information

Style Number	U.S. Base Price
.....

With Arms

TS38308	\$445
.....



Without Arms

TS38309	\$414
.....



▶ Detailed dimensions,
page 110

Multi-Use Chair, Leather, with Casters

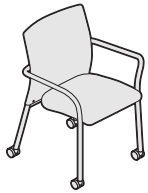

Standard Includes		Required to Specify
<ul style="list-style-type: none"> ▶ Need help? Product details, page 106 	<ul style="list-style-type: none"> • Back: mesh • Seat: black leather • Arms, if selected: black • Steel four-leg frame: black • Hard dual-wheel casters: black • Stacks four high 	<ul style="list-style-type: none"> 1 Style number 2 Mesh color number for back: <ul style="list-style-type: none"> T084 Black T085 Grey T086 White T087 Yellow T088 Orange T089 Red T090 Green T091 Blue T094 Cardinal 3 Options, if selected (see below)

Options	U.S. Price	Required to Specify
Surface Materials <ul style="list-style-type: none"> • 4799 Platinum aluminum frame 	+\$50	Specify with 4799 Platinum.
Jersey Pullover <ul style="list-style-type: none"> • Stretch pullover 	+\$70	Specify with jersey pullover and select color number: <ul style="list-style-type: none"> T092 Black T095 Yellow T096 Orange T097 Red T098 Green T099 Blue
Casters <ul style="list-style-type: none"> • Soft dual-wheel casters for use on hard floors 	+\$25	Specify with soft casters.

Specification Information	
Style Number	U.S. Base Price
.....

With Arms

TS38310	\$526
.....

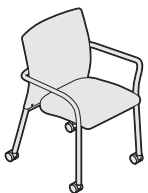

Without Arms

TS38311	\$495
.....



▶ Detailed dimensions, page 110

Jersey Pullover

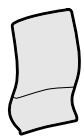

Standard Includes	Required to Specify
<ul style="list-style-type: none"> • Stretch pullover 	<ul style="list-style-type: none"> 1 Style number 2 Color number for stretch pullover: <ul style="list-style-type: none"> T092 Black T095 Yellow T096 Orange T097 Red T098 Green T099 Blue

Specification Information	
• Style Number	• U.S. Price
TS38303	\$70
•	•
•	•

Jersey Series

US For **164** U.S., multiply all **162** U.S. prices by 1.03. Multiply **164** U.S. by 1.2 for **138** Canadian price. ▶ See page 1 for details.



Understanding and Specifying Sensor 458 Series Work Chairs

Understanding Sensor 458 Series

Details	122
Dimension Variations	124
Dimensions	126

Specifying Sensor 458 Series

Work Chairs	128
Sled-Base Multi-Use Chairs	136

Work Chairs

Highly adjustable task seating offers maximum personalization for people who sit most of the day performing repetitive tasks. By making a series of simple adjustments, you can customize the chair to your body, preferences, and tasks. These chairs provide continuous, stable, task-oriented comfort, and can be quickly adjusted to support you in upright, forward, and reclining work postures.

- Leap 462 Series
- Leap 464 Series
- Siento 499 Series
- Criterion 453 Series
- Think 465 Series
- Drive 461 Series
- Jersey Series
- Sensor 458 Series

Adjustability Features

► See page 11 for a comparison to other chairs.

Sensor 458 Series

Mechanisms

Synchro-tilt	●
--------------	---

Seat Adjustments

Pneumatic height	●
------------------	---

Back Adjustments

Lumbar height	●
---------------	---

Back tension	●
--------------	---

Variable back stop	●
--------------------	---

Back height	●
-------------	---

Arm Adjustments

Arm height	●
------------	---

Arm width	●
-----------	---

Sensor 458 Series

Sensor's timeless styling and innovative self-adjusting design offer an exceptionally broad range of high-performance models to meet the needs of virtually everyone throughout an organization.

Outer back and outer seat are plastic. Fully upholstered outer back is an option.



Five-arm base is standard.

Arm caps are soft vinyl.

Seat height adjusts within a 5" range, from 16"H to 21"H.

Casters have hard, dual wheels that roll smoothly on carpets. Soft, dual-wheel casters are available for use on hard floors or chair mats.

Product Details



Work chairs are available in Size II mid- or high-back and Size II adjustable back.



Sled-based multi-use chairs are available in mid-back styles.

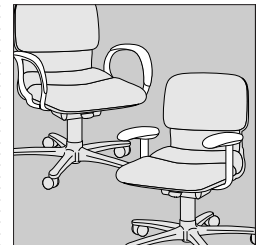

Arm styles include omega arms, adjustable-height and width arms, and armless models.

Adjustment Features

Seat Adjustments

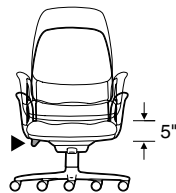

Seat height adjusts pneumatically. To lower, pull lever on right side while seated. To raise, pull lever and lift your weight off the chair.

Back Adjustments

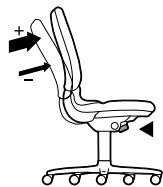

Back tension adjusts by turning knob. Turn knob clockwise to increase tension, counterclockwise to decrease.

Tip: Be sure to unlock (release) the variable back stop before adjusting the back tension.

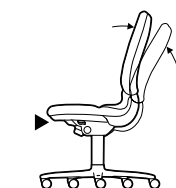

Variable back stop.

Flick switch forward for full range of back angles. To limit back angle, recline to the desired position and flick switch back.

Tip: To lock in upright position, remove weight from back and flick switch back.

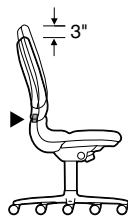

Back height adjusts up to 3" by holding button in while moving chair back up or down. Releasing button locks chair back in position.

Tip: Available only on Size II adjustable back models.

Arm Adjustments

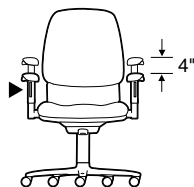

Arm height adjusts independently within a range of 4". Squeeze triggers in while moving arms up or down. Releasing triggers locks arms in position.

Tip: Available only on work chairs.

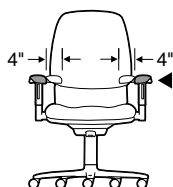

Arm width adjusts independently within a 4" range on chairs with this option. Grasp arm and move in or out. Arm will stay where positioned.

Surface Materials

► See surface materials on page 248 for specific availability or refer to the *Surface Materials Reference Manual* for further information.

Upholstery

- Fabric
- Fabric with soil-retardant treatment (option)
- Leather

Hard components

(base, arms, soft vinyl arm caps, outer back, frame, and casters)

- Monochromatic color from list of seating plastic color numbers will apply to all hard components.

Outer back

- Plastic color to match monochromatic color of other "hard components"
- Fully upholstered

Sled base

- Plastic color to match color of other "hard components"

Arms

- Plastic color to match color of other "hard components"

Arm caps

- Soft vinyl to match monochromatic color of other "hard components"

Glides

- Stainless steel on sled-base models

All Steelcase seating with standard upholstery fabrics complies with requirements of the BIFMA First Generation Voluntary Upholstered Furniture Flammability Standard, as well as the State of California Technical Bulletin 117. All standard seating is labeled to be in compliance with California TB117.

Programs & Services

► See the *Surface Materials Reference Manual* for further detail about programs and services offered for seating.

The Customer's Own Material (COM)

Program offers the opportunity for customers to select fabrics that are not offered through the standard Steelcase surface materials program for use on Steelcase products. Through the COM program, Steelcase will test your materials for application on Steelcase products.

Once approved, you can place your order. Steelcase will facilitate the entire ordering process and give you a production schedule. Steelcase will order the COM fabric directly from the textile manufacturer. For up-to-date information regarding fabric test results for all COM fabrics and details regarding yardage requirements for most Seating lines, visit the COM Web site. To locate the COM Web site:

- Visit www.steelcase.com
- Click on "Knowledge & Design"
- Select "Customer's Own Material"

Soil retardants are treatments that provide long-term soil and stain resistance to a fabric without affecting the shade or the integrity of the fabric. The following Steelcase Textiles are available pre-treated with soil retardant. (You do not need to select the soil-retardant option for these fabrics and incur the upcharge.)

- Jacks
- Link
- Regis
- Skittles
- Roulette
- Spyder

Soil-retardant treatment is available on all other seating fabrics at an additional upcharge per seating unit. To order this option, please select "Soil-Retardant Treatment" under "Optional Accessories."

For soil-retardant treatment on COMs, please select "Soil-Retardant Treatment" under "Optional Accessories." Minimums or additional yardage may be required. Please contact the vendor directly for specific information.

Extended lead times may be necessary for this service.

Contact your Steelcase Solutions Fulfillment Team Representative at 1.888.STEELCASE (1.888.783.3522).

Fire Codes

► See pages 254–255 for upholstery fabrics available for use with FCS modification. Sensor Size II adjustable-back models offer the Fire Code Seating option on the following upholstery fabrics only: Hampstead and Leather.

Steelcase offers Fire Code Seating modification (FCS) on nearly all seating models. The most rigorous fire codes in the nation have been developed in California, and the Steelcase FCS modification is designed to meet those codes. Fire Code Seating (FCS) indicates that a product is constructed to meet the strict fire code requirements of high public occupancy areas such as theaters, meeting rooms, and lobbies. The FCS standards will meet both the State of California Home Furnishing Technical Bulletin 133 (Cal TB 133) and Boston Fire Code (BFC). Boston adopted the California Home Furnishing Technical Bulletin TB 133 test standard in 1992.

Local codes may have special requirements for upholstery.

Dimensions

► Pages 124 and 126

Resources

Printed Materials

- Sensor Brochure (04-1251642)
- Seating Overview (06-0000890)

Computer Tools

- Electronic User Disk (S2338)—Windows

Dimension Variations

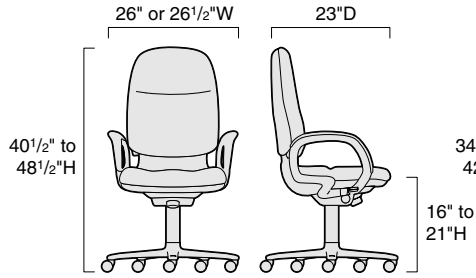

Work Chair
Size II Adjustable High-Back

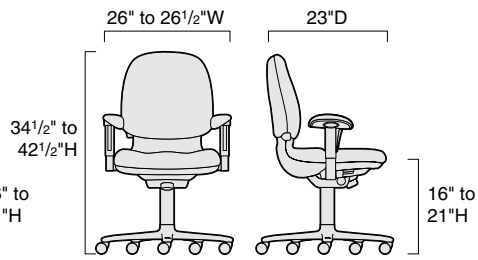

Work Chair
Size II Adjustable Back

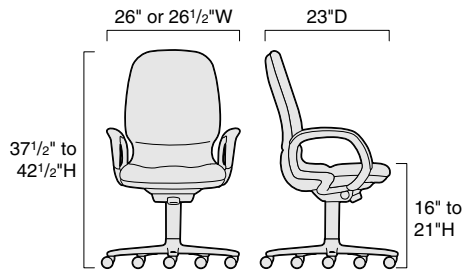

Work Chair
Size II High-Back

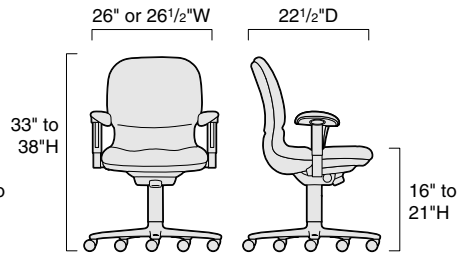

Work Chair
Size II Mid-Back

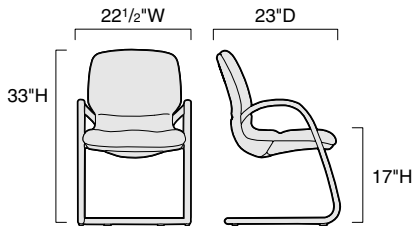

Sled-Base Multit-Use Chair
Size II Mid-Back

Dimensions

Sensor 458 Series

Type of Chair	Overall Depth	Width	Height	Seat Depth	Functional Seat Depth	Seat Width	Seat Height from Floor	Back Width	Back Height from Seat
---------------	---------------	-------	--------	------------	-----------------------	------------	------------------------	------------	-----------------------

Sensor 458 Series

Size II Adjustable High-Back Work Chairs

Omega Arms	23"	26"	40½"-48½"	18¼"	16¾"	20¼"	16"-21"	18"	24¼"-27¼"
Adjustable Arms	23"	26½"	40½"-48½"	18¼"	16¾"	20¼"	16"-21"	18"	24¼"-27¼"

Size II Adjustable-Back Work Chairs

Omega Arms	22"	26"	34½"-42½"	18¼"	16¾"	20¼"	16"-21"	18"	18¼"-21¼"
Adjustable Arms	22"	26½"	34½"-42½"	18¼"	16¾"	20¼"	16"-21"	18"	18¼"-21¼"

Size II High-Back Work Chairs

Omega Arms	23"	26"	37½"-42½"	17¾"	16½"	19¾"	16"-21"	18"	21½"
Adjustable Arms	23"	26½"	37½"-42½"	17¾"	16½"	19¾"	16"-21"	18"	21½"

Size II Mid-Back Work Chairs

Omega Arms	22½"	26"	33"-38"	17¾"	16½"	19¾"	16"-21"	18"	17"
Adjustable Arms	22½"	26½"	33"-38"	17¾"	16½"	19¾"	16"-21"	18"	17"

Size II Mid-Back Sled-Base Multi-Use Chairs

Loop Arms	23"	22½"	33"	17¾"	16½"	19¾"	17"	18"	17"
-----------	-----	------	-----	------	------	------	-----	-----	-----

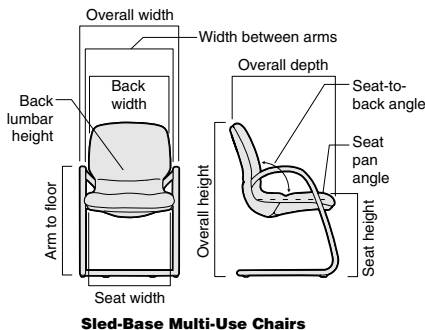
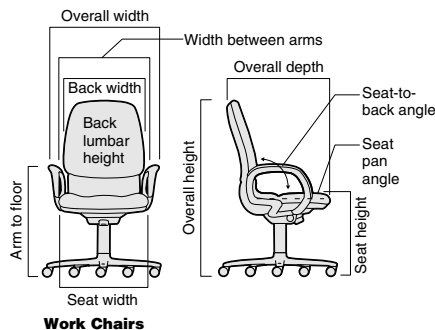

• Back • Lumbar • Height	• Width • Between • Arms	• Arm • to • Floor	• Arm • Height • from • Seat	• Seat • Pan • Angle	• Angle • Between • Seat and • Back
--------------------------------	--------------------------------	--------------------------	---------------------------------------	----------------------------	--

Size II Adjustable High-Back Work Chairs

7"-10"	20½"	24½"-29½"	8"	1°-4°	100°-110°
7"-10"	12¼"-20¼"	23¼"-32¼"	8¾"-12¾"	1°-4°	100°-110°

Size II Adjustable-Back Work Chairs

7"-10"	20½"	24½"-29½"	8"	1°-4°	100°-110°
7"-10"	12¼"-20¼"	23¼"-32¼"	8¾"-12¾"	1°-4°	100°-110°

Size II High-Back Work Chairs

8"	20¼"	24½"-29½"	8"	1°-4°	105°-120°
8"	12"-20"	23¼"-32¼"	8¾"-12¾"	1°-4°	105°-120°

Size II Mid-Back Work Chairs

8"	20¼"	24½"-29½"	8"	1°-4°	105°-120°
8"	12"-20"	23¼"-32¼"	8¾"-12¾"	1°-4°	105°-120°

Size II Mid-Back Sled-Base Multi-Use Chairs

8"	19"	23¾"	8"	1°-4°	105°
----	-----	------	----	-------	------

Sensor 458 Series Size II Adjustable High-Back Work Chairs



Tip: Back height may be adjusted 3".

Tip: Always add suffixes in alphabetical order when specifying options to Sensor seating.

Tip: Fire Code Seating (FCS) option is available only on models with 6205 Black plastic components.
▶ See pages 254–255 for upholstery fabric choices.

Standard Includes		Required to Specify	
▶ Need help? Product details, page 122	<ul style="list-style-type: none"> • Synchro-tilt mechanism • Arms: plastic color to match base • Outer back and outer seat: plastic color • Back tension adjustment • Upholstery: fabric price group 1 • Five-arm base: plastic color • 2½"-diameter, hard composition, dual-wheel casters: plastic color to match base 	<ol style="list-style-type: none"> 1 Style number 2 Plastic color number for base, outer back, outer seat, arms, and casters 3 Fabric color number for upholstery 4 Options, if selected (see below) 	▶ See <i>Surface Materials</i> , page 248.

Options	U.S. Price	Required to Specify	
Surface Materials			
Upholstery			
• Fabric price group 1	No cost	Specify fabric color number.	
• Fabric price group 2	+\$ 20	Specify fabric color number.	
• Fabric price group 3	+\$ 40	Specify fabric color number.	
• Fabric price group 4	+\$ 55	Specify fabric color number.	
• Fabric price group 5	+\$ 70	Specify fabric color number.	
• Fabric price group 6	+\$ 100	Specify fabric color number.	
• Fabric price group 7	+\$ 140	Specify fabric color number.	
• Fabric price group 8	+\$ 185	Specify fabric color number.	
• Fabric price group 9	+\$ 220	Specify fabric color number.	
• Fabric price group 10	+\$ 255	Specify fabric color number.	
• Customer's Own Material (COM)	+\$ 30	▶ See <i>Surface Materials Reference Manual</i> to specify.	
• Steelcase leather upholstery	+\$ 856	Add suffix S to the style number and specify leather color number for upholstery.	
• Customer's Own Leather (COL)	+\$ 590	Add suffix S to the style number.	
		▶ See <i>Surface Materials Reference Manual</i> to specify.	
• Fire Code Seating (FCS)	+\$ 55	Add suffix F to the style number.	
• Soil-retardant treatment applied to upholstery fabric	+\$ 20	Specify <i>with soil-retardant treatment</i> .	
Fully upholstered			
• Fabric fully upholstered outer back and outer seat	+\$ 140	Add suffix U to the style number.	
• Steelcase leather fully upholstered outer back and outer seat	+\$1277	Add suffix SU to the style number and specify leather color number.	
• Customer's Own Leather (COL) fully upholstered outer back and outer seat	+\$ 891	Add suffix SU to the style number.	
		▶ See <i>Surface Materials Reference Manual</i> to specify.	
Casters			
• Soft, dual-wheel casters for use on hard floors	+\$ 18	Specify <i>with soft casters</i> .	

▶ Detailed dimensions, page 126

US 

For **164** U.S., multiply all **162** U.S. prices by 1.03.
Multiply **164** U.S. by 1.2 for **138** Canadian price.
▶ See page 1 for details.

Specification Information

Height- and Width-Adjustable Arms



• **Style Number**
:
:
:
:
:

• **U.S. Base Price**
:
:
:
:
:

Omega Arms



• **Style Number**
:
:
:
:
:

• **U.S. Base Price**
:
:
:
:
:

Pneumatic

4581237W \$1360

4581227 \$1193

Pneumatic with Variable Back Stop

4581437W \$1423

4581427 \$1256

US 

For **164** U.S., multiply all **162** U.S. prices by 1.03.
Multiply **164** U.S. by 1.2 for **138** Canadian price.
▶ See page 1 for details.

Sensor 458 Series Size II Adjustable-Back Work Chairs



Tip: Back height may be adjusted 3".

Tip: Leather upholstery is available on Size II adjustable-back models. Order through Specials.

Tip: Fire Code Seating (FCS) option is available only on models with 6205 Black plastic components. ▶ See pages 254–255 for upholstery fabric choices.

Tip: Always add suffixes in alphabetical order when specifying options to Sensor seating.

Standard Includes		Required to Specify
▶ Need help? Product details, page 122	<ul style="list-style-type: none"> • Synchro-tilt mechanism • Back tension adjustment • Arms, if selected: plastic color to match base • Outer back and outer seat: plastic color • Upholstery: fabric price group 1 • Five-arm base: plastic color • 2½"-diameter, hard composition, dual-wheel casters: plastic color to match base 	1 Style number 2 Plastic color number for base, outer back, outer seat, arms, and casters 3 Fabric color number for upholstery 4 Options, if selected (see below) ▶ See <i>Surface Materials</i> , page 248.

Options	U.S. Price	Required to Specify
Surface Materials <ul style="list-style-type: none"> • Fabric price group 1 • Fabric price group 2 • Fabric price group 3 • Fabric price group 4 • Fabric price group 5 • Fabric price group 6 • Fabric price group 7 • Fabric price group 8 • Fabric price group 9 • Fabric price group 10 • Customer's Own Material (COM) • Fire Code Seating (FCS) • Soil-retardant treatment applied to upholstery fabric 	No cost +\$ 20 +\$ 40 +\$ 55 +\$ 70 +\$100 +\$140 +\$185 +\$220 +\$255 +\$ 30 +\$ 55 +\$ 20	Specify fabric color number. Specify fabric color number. Specify fabric color number. Specify fabric color number. Specify fabric color number. Specify fabric color number. Specify fabric color number. Specify fabric color number. Specify fabric color number. Specify fabric color number. ▶ See <i>Surface Materials Reference Manual</i> to specify. Add suffix F to the style number. Specify <i>with soil-retardant treatment</i> .
Fully upholstered <ul style="list-style-type: none"> • Fabric fully upholstered outer back and outer seat 	+\$140	Add suffix U to the style number.
Casters <ul style="list-style-type: none"> • Soft, dual-wheel casters for use on hard floors 	+\$ 18	Specify <i>with soft casters</i> .

Specification Information

Height- and Width-Adjustable Arms



• Style Number
• U.S. Base Price

Omega Arms



• Style Number
• U.S. Base Price

With Arm Caps

Pneumatic

4581236W	\$1233	4581226	\$1066
-----------------	--------	----------------	--------

Pneumatic with Variable Back Stop

4581436W	\$1296	4581426	\$1129
-----------------	--------	----------------	--------

▶ Specification Information continued on next page

▶ Detailed dimensions, page 126



For **164** U.S., multiply all **162** U.S. prices by 1.03. Multiply **164** U.S. by 1.2 for **138** Canadian price. ▶ See page 1 for details.

► **Specification Information, continued**

Specification Information



• Style Number	• U.S. Base Price
---------------------------	----------------------------------

Without Arms

Pneumatic

4581206	\$935
----------------	-------

Pneumatic with Variable Back Stop

4581406	\$998
----------------	-------

:	:
---	---

US

For **164** U.S., multiply all
162 U.S. prices by 1.03.
Multiply **164** U.S. by 1.2 for
138 Canadian price.
► See page 1 for details.

Sensor 458 Series Size II High-Back Work Chairs



	Standard Includes	Required to Specify
▶ Need help? Product details, page 122	<ul style="list-style-type: none"> • Synchro-tilt mechanism • Arms, if selected: plastic color to match base • Back tension adjustment • Outer back and outer seat: plastic color • Upholstery: fabric price group 1 • Five-arm base: plastic color • 2½"-diameter, hard composition, dual-wheel casters: plastic color to match base 	<ol style="list-style-type: none"> 1 Style number 2 Plastic color number for base, outer back, outer seat, arms, and casters 3 Fabric color number for upholstery 4 Options, if selected (see below) <p>▶ See <i>Surface Materials</i>, page 248.</p>

	Options	U.S. Price	Required to Specify
Surface Materials	Upholstery		
	• Fabric price group 1	No cost	Specify fabric color number.
	• Fabric price group 2	+\$ 20	Specify fabric color number.
	• Fabric price group 3	+\$ 40	Specify fabric color number.
	• Fabric price group 4	+\$ 55	Specify fabric color number.
	• Fabric price group 5	+\$ 70	Specify fabric color number.
	• Fabric price group 6	+\$ 100	Specify fabric color number.
	• Fabric price group 7	+\$ 140	Specify fabric color number.
	• Fabric price group 8	+\$ 185	Specify fabric color number.
	• Fabric price group 9	+\$ 220	Specify fabric color number.
• Fabric price group 10	+\$ 255	Specify fabric color number.	
• Customer's Own Material (COM)	+\$ 30	▶ See <i>Surface Materials Reference Manual</i> to specify.	
• Steelcase leather upholstery	+\$ 856	Add suffix S to the style number and specify leather color number for upholstery.	
• Customer's Own Leather (COL)	+\$ 590	Add suffix S to the style number.	
• Fire Code Seating (FCS)	+\$ 55	▶ See <i>Surface Materials Reference Manual</i> to specify.	
• Soil-retardant treatment applied to upholstery fabric	+\$ 20	Add suffix F to the style number. Specify <i>with soil-retardant treatment</i> .	
	Fully upholstered		
	• Fabric fully upholstered outer back and outer seat	+\$ 140	Add suffix U to the style number.
	• Steelcase leather fully upholstered outer back and outer seat	+\$1277	Add suffix SU to the style number and specify leather color number.
	• Customer's Own Leather (COL) fully upholstered outer back and outer seat	+\$ 891	Add suffix SU to the style number.
			▶ See <i>Surface Materials Reference Manual</i> to specify.
Casters	• Soft, dual-wheel casters for use on hard floors	+\$ 18	Specify <i>with soft casters</i> .

Tip: Always add suffixes in alphabetical order when specifying options to Sensor seating.

Tip: Fire Code Seating (FCS) option is available only on models with 6205 Black plastic components.
▶ See pages 254–255 for upholstery fabric choices.

▶ Detailed dimensions, page 126

US 

For **164** U.S., multiply all **162** U.S. prices by 1.03.
Multiply **164** U.S. by 1.2 for **138** Canadian price.
▶ See page 1 for details.

Specification Information

Height- and Width-Adjustable Arms



• **Style Number**
• **U.S. Base Price**

Omega Arms



• **Style Number**
• **U.S. Base Price**

With Arm Caps

Pneumatic

4581234W	\$1165	4581224	\$ 998
-----------------	--------	----------------	--------

Pneumatic with Variable Back Stop

4581434W	\$1228	4581424	\$1061
-----------------	--------	----------------	--------



• **Style Number**
• **U.S. Base Price**

Without Arms

Pneumatic

4581204	\$ 867
----------------	--------

Pneumatic with Variable Back Stop

4581404	\$ 930
----------------	--------

US 
For **164** U.S., multiply all **162** U.S. prices by 1.03.
Multiply **164** U.S. by 1.2 for **138** Canadian price.
▶ See page 1 for details.

Sensor 458 Series Size II Mid-Back Work Chairs



	Standard Includes	Required to Specify
▶ Need help? Product details, page 122	<ul style="list-style-type: none"> • Synchro-tilt mechanism • Arms, if selected: plastic color to match base • Outer back and outer seat: plastic color • Back tension adjustment • Upholstery: fabric price group 1 • Five-arm base: plastic color • 2½"-diameter, hard composition, dual-wheel casters: plastic color to match base 	<ol style="list-style-type: none"> 1 Style number 2 Plastic color number for base, outer back, outer seat, arms, and casters 3 Fabric color number for upholstery 4 Options, if selected (see below) <p>▶ See <i>Surface Materials</i>, page 248.</p>

	Options	U.S. Price	Required to Specify
Surface Materials	Upholstery		
	• Fabric price group 1	No cost	Specify fabric color number.
	• Fabric price group 2	+\$ 20	Specify fabric color number.
	• Fabric price group 3	+\$ 40	Specify fabric color number.
	• Fabric price group 4	+\$ 55	Specify fabric color number.
	• Fabric price group 5	+\$ 70	Specify fabric color number.
	• Fabric price group 6	+\$ 100	Specify fabric color number.
	• Fabric price group 7	+\$ 140	Specify fabric color number.
	• Fabric price group 8	+\$ 185	Specify fabric color number.
	• Fabric price group 9	+\$ 220	Specify fabric color number.
• Fabric price group 10	+\$ 255	Specify fabric color number.	
• Customer's Own Material (COM)	+\$ 30	▶ See <i>Surface Materials Reference Manual</i> to specify.	
• Steelcase leather upholstery	+\$ 856	Add suffix S to the style number and specify leather color number for upholstery.	
• Customer's Own Leather (COL)	+\$ 590	Add suffix S to the style number.	
• Fire Code Seating (FCS)	+\$ 55	▶ See <i>Surface Materials Reference Manual</i> to specify.	
• Soil-retardant treatment applied to upholstery fabric	+\$ 20	Add suffix F to the style number. Specify <i>with soil-retardant treatment</i> .	
	Fully upholstered		
	• Fabric fully upholstered outer back and outer seat	+\$ 140	Add suffix U to the style number.
	• Steelcase leather fully upholstered outer back and outer seat	+\$1277	Add suffix SU to the style number and specify leather color number.
	• Customer's Own Leather (COL) fully upholstered outer back and outer seat	+\$ 891	Add suffix SU to the style number.
			▶ See <i>Surface Materials Reference Manual</i> to specify.
Casters	• Soft, dual-wheel casters for use on hard floors	+\$ 18	Specify <i>with soft casters</i> .

Tip: Always add suffixes in alphabetical order when specifying options to Sensor seating.

Tip: Fire Code Seating (FCS) option is available only on models with 6205 Black plastic components.
▶ See pages 254–255 for upholstery fabric choices.

▶ Detailed dimensions, page 126



For **164** U.S., multiply all **162** U.S. prices by 1.03.
Multiply **164** U.S. by 1.2 for **138** Canadian price.
▶ See page 1 for details.

Specification Information

Height- and Width-Adjustable Arms



• **Style Number**
• **U.S. Base Price**

Omega Arms



• **Style Number**
• **U.S. Base Price**

With Arm Caps

Pneumatic

4581233W	\$1114	4581223	\$ 947
-----------------	--------	----------------	--------

Pneumatic with Variable Back Stop

4581433W	\$1177	4581423	\$1010
-----------------	--------	----------------	--------



• **Style Number**
• **U.S. Base Price**

Without Arms

Pneumatic

4581203	\$ 816
----------------	--------

Pneumatic with Variable Back Stop

4581403	\$ 879
----------------	--------

US 
 For **164** U.S., multiply all **162** U.S. prices by 1.03.
 Multiply **164** U.S. by 1.2 for **138** Canadian price.
 ▶ See page 1 for details.

Sensor 458 Series Size II Mid-Back Sled-Base Multi-Use Chairs



Tip: Always add suffixes in alphabetical order when specifying options to Sensor seating.

Tip: Fire Code Seating (FCS) option is available only on models with 6205 Black plastic components.
▶ See pages 254–255 for upholstery fabric choices.

Standard Includes	Required to Specify
<ul style="list-style-type: none"> ▶ Need help? Product details, page 122 • Frame and arms: plastic color • Outer back and outer seat: plastic color • Upholstery: fabric price group 1 • Stainless steel glides 	<ol style="list-style-type: none"> 1 Style number 2 Plastic color number for frame, outer back, outer seat, and arms 3 Fabric color number for upholstery 4 Options, if selected (see below) <p>▶ See <i>Surface Materials</i>, page 248.</p>

Options	U.S. Price	Required to Specify
Surface Materials		
Upholstery <ul style="list-style-type: none"> • Fabric price group 1 • Fabric price group 2 • Fabric price group 3 • Fabric price group 4 • Fabric price group 5 • Fabric price group 6 • Fabric price group 7 • Fabric price group 8 • Fabric price group 9 • Fabric price group 10 • Customer's Own Material (COM) • Steelcase leather upholstery • Customer's Own Leather (COL) • Fire Code Seating (FCS) • Soil-retardant treatment applied to upholstery fabric 	No cost +\$ 20 +\$ 40 +\$ 55 +\$ 70 +\$ 100 +\$ 140 +\$ 185 +\$ 220 +\$ 255 +\$ 30 +\$ 856 +\$ 590 +\$ 55 +\$ 20	Specify fabric color number. Specify fabric color number. Specify fabric color number. Specify fabric color number. Specify fabric color number. Specify fabric color number. Specify fabric color number. Specify fabric color number. Specify fabric color number. Specify fabric color number. Specify fabric color number. ▶ See <i>Surface Materials Reference Manual</i> to specify. Add suffix S to the style number and specify leather color number for upholstery. Add suffix S to the style number. ▶ See <i>Surface Materials Reference Manual</i> to specify. Add suffix F to the style number. Specify with soil-retardant treatment.
Fully upholstered <ul style="list-style-type: none"> • Fabric fully upholstered outer back and outer seat • Steelcase leather fully upholstered outer back and outer seat • Customer's Own Leather (COL) fully upholstered outer back and outer seat 	+\$ 140 +\$1277 +\$ 891	Add suffix U to the style number. Add suffix SU to the style number and specify leather color number. Add suffix SU to the style number. ▶ See <i>Surface Materials Reference Manual</i> to specify.

Specification Information



• Style Number
• U.S. Base Price



• Style Number
• U.S. Base Price

With Arm Caps

4585023 \$621

Without Arm Caps

4585093 \$602

▶ Detailed dimensions, page 126

US 
 For **164** U.S., multiply all **162** U.S. prices by 1.03.
 Multiply **164** U.S. by 1.2 for **138** Canadian price.
 ▶ See page 1 for details.

Understanding and Specifying Rally 457 Series Work Chairs

Understanding Rally 457 Series

Details	138
Dimensions	140

Specifying Rally 457 Series

Work Chairs	142
Mid-Back Multi-Use Chairs	144

Work Chairs

Adjustable work chairs offer basic ergonomic comfort for people who have varied tasks and tend to be in and out of the office during the day. Features include adjustable seat height, back tension, and upright back lock. Also featured is the no front-rise seat—in other words, when you lean back, the front edge of the seat doesn't rise up, lifting your legs off the floor and cutting off circulation.

- Rally 457 Series
- Protégé 433 Series
- Cachet 487 Series

Adjustability Features

▶ See page 11 for a comparison to other chairs

Rally 457 Series

Mechanisms

Advanced swivel-tilt	●
----------------------	---

Seat Adjustments

Pneumatic height	●
------------------	---

Back Adjustments

Upright back lock	●
-------------------	---

Back tension	●
--------------	---

Rally 457 Series

Rally is contemporary in design with soft, pleasing contours. Rally features basic adjustments at an attractive price.

Outer back and outer seat are plastic. Fully upholstered outer back and outer seat is available.

Five-arm base is standard.



Arms are available to match the outer back and base.

Seat height adjusts within a 5" range from 16"H to 21"H on work chairs with a pneumatic adjustment mechanism.

Hard, dual-wheel casters are provided for use on carpets. Soft, dual-wheel casters are available for use on hard floors or chair mats.

Product Details



High-back and mid-back work chairs are available.



Multi-use chair bases are available in two styles: fixed-height swivel and sled.

Adjustment Features

Seat Adjustments

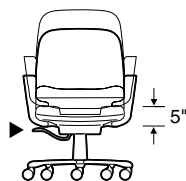

Seat height adjusts pneumatically. To lower, hold handle up while seated. To raise, hold handle up and lift your weight off the chair.
Tip: Multi-use chairs are fixed height only and do not include back tension adjustment.

Back Adjustments



Back tension adjusts by turning knob. Turn knob clockwise to increase tension, counterclockwise to decrease.



Upright back lock. Pull knob out to release back; push knob in to lock back.

Surface Materials

► See surface materials on page 248 for specific availability or refer to the *Surface Materials Reference Manual* for further information.

Upholstery

- Fabric
- Fabric with soil-retardant treatment (option)
- Leather

Hard components

(base, arms, plastic arm caps, outer back, outer seat, frame, and casters)

- Monochromatic color from list of seating plastic color numbers will apply to all hard components.

Outer back and outer seat

- Plastic color to match monochromatic color of other “hard components”
- Fully upholstered

Sled base

- Plastic color to match color of other “hard components”

Arms

- Plastic color to match color of other “hard components”

Glides

- Plastic on sled-base chair

All Steelcase seating with standard upholstery fabrics complies with requirements of the BIFMA First Generation Voluntary Upholstered Furniture Flammability Standard, as well as the State of California Technical Bulletin 117. All standard seating is labeled to be in compliance with California TB117.

Programs & Services

► See the *Surface Materials Reference Manual* for further detail about programs and services offered for seating.

The Customer's Own Material (COM) Program

offers the opportunity for customers to select fabrics that are not offered through the standard Steelcase surface materials program for use on Steelcase products. Through the COM program, Steelcase will test your materials for application on Steelcase products. Once approved, you can place your order. Steelcase will facilitate the entire ordering process and give you a production schedule. Steelcase will order the COM fabric directly from the textile manufacturer. For up-to-date information regarding fabric test results for all COM fabrics and details regarding yardage requirements for most Seating lines, visit the COM Web site. To locate the COM Web site:

- Visit www.steelcase.com
- Click on “Knowledge & Design”
- Select “Customer's Own Material”

Soil retardants are treatments that provide long-term soil and stain resistance to a fabric without affecting the shade or the integrity of the fabric. The following Steelcase Textiles are available pre-treated with soil retardant. (You do not need to select the soil-retardant option for these fabrics and incur the upcharge.)

- Jacks
- Link
- Regis
- Roulette
- Skittles
- Spyder

Soil-retardant treatment is available on all other seating fabrics at an additional upcharge per seating unit. To order this option, please select “Soil-Retardant Treatment” under “Optional Accessories.”

For soil-retardant treatment on COMs, please select “Soil-Retardant Treatment” under “Optional Accessories.” Minimums or additional yardage may be required. Please contact the vendor directly for specific information.

Extended lead times may be necessary for this service.

Contact your Steelcase Solutions Fulfillment Team Representative at 1.888.STEELCASE (1.888.783.3522).

Fire Codes

► See pages 254–255 for upholstery fabrics available for use with FCS modification.

Steelcase offers Fire Code Seating modification (FCS) on nearly all seating models. The most rigorous fire codes in the nation have been developed in California, and the Steelcase FCS modification is designed to meet those codes. Fire Code Seating (FCS) indicates that a product is constructed to meet the strict fire code requirements of high public occupancy areas such as theaters, meeting rooms, and lobbies. The FCS standards will meet both the State of California Home Furnishing Technical Bulletin 133 (Cal TB 133) and Boston Fire Code (BFC). Boston adopted the California Home Furnishing Technical Bulletin TB 133 test standard in 1992.

Local codes may have special requirements for upholstery.

Dimensions

► Page 140

Resources

Printed Materials

- Rally Brochure (04-0000162)
- Seating Overview (06-0000890)

Dimensions

Rally 457 Series

Features	Overall Depth	Width	Height	Seat Depth	Functional Seat Depth	Seat Width	Seat Height from Floor	Back Width	Back Height from Seat
----------	---------------	-------	--------	------------	-----------------------	------------	------------------------	------------	-----------------------

Rally 457 Series

High-Back Work Chairs

Pneumatic	22 ⁵ / ₈ "	26 ¹ / ₂ "	34"-39"	17 ⁷ / ₈ "	15 ¹ / ₂ "	20"	16"-21"	20"	20 ³ / ₄ "
-----------	----------------------------------	----------------------------------	---------	----------------------------------	----------------------------------	-----	---------	-----	----------------------------------

Mid-Back Work Chairs

Pneumatic	22 ³ / ₈ "	26 ¹ / ₂ "	33"-38"	17 ⁷ / ₈ "	15 ¹ / ₂ "	20"	16"-21"	20"	19 ¹ / ₄ "
-----------	----------------------------------	----------------------------------	---------	----------------------------------	----------------------------------	-----	---------	-----	----------------------------------

Mid-Back Multi-Use Chairs

Swivel/Fixed Base	22 ¹ / ₄ "	26 ¹ / ₂ "	34"	17 ⁷ / ₈ "	15 ¹ / ₂ "	20"	18"	20"	19 ¹ / ₄ "
-------------------	----------------------------------	----------------------------------	-----	----------------------------------	----------------------------------	-----	-----	-----	----------------------------------

Sled Base	22 ¹ / ₂ "	23"	33 ³ / ₄ "	17 ⁷ / ₈ "	15 ¹ / ₂ "	20"	18"	20"	19 ¹ / ₄ "
-----------	----------------------------------	-----	----------------------------------	----------------------------------	----------------------------------	-----	-----	-----	----------------------------------

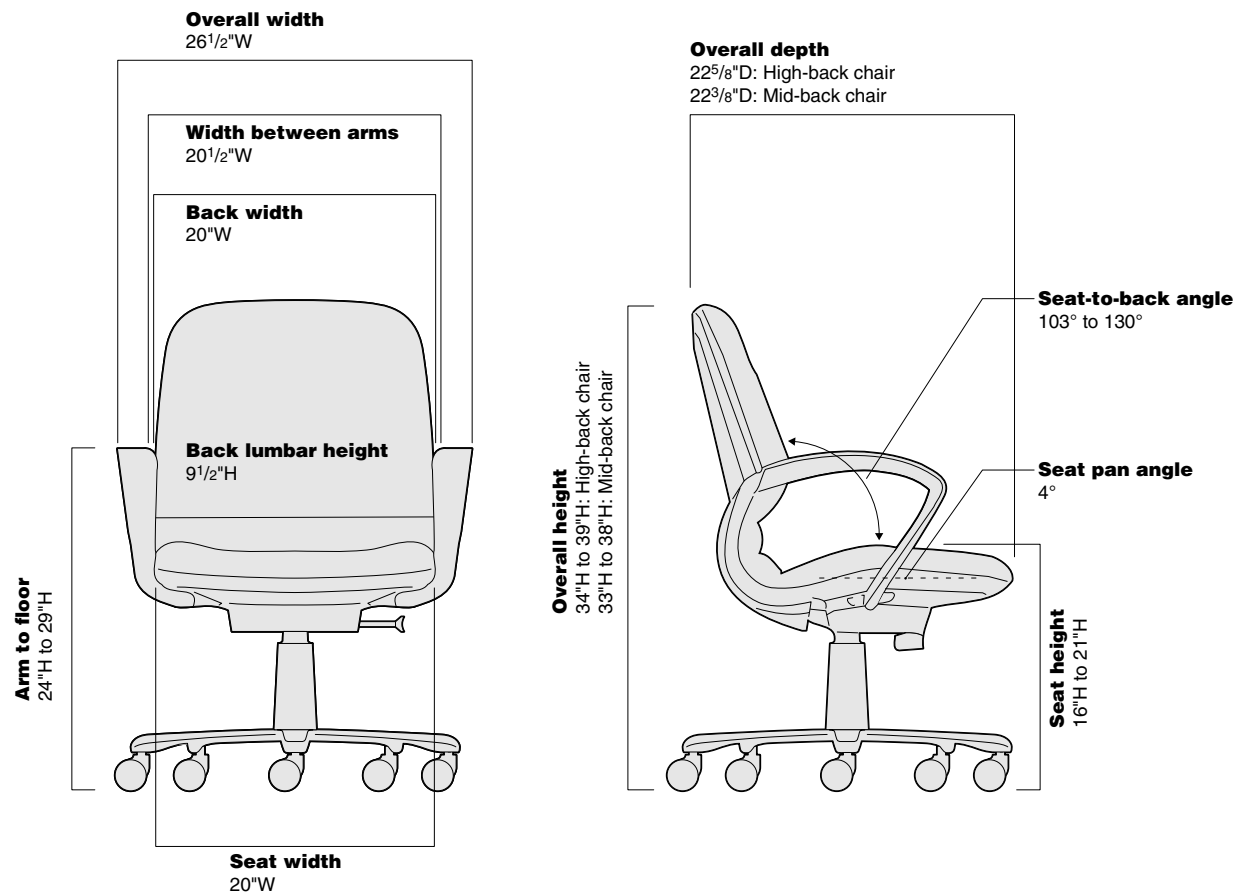

• Back • Lumbar • Height	• Width • Between • Arms	• Arm • to • Floor	• Arm • Height • from • Seat	• Seat • Pan • Angle	• Angle • Between • Seat and • Back
--------------------------------	--------------------------------	--------------------------	---------------------------------------	----------------------------	--

High-Back Work Chairs

9½"	20½"	24"-29"	8"	4°	103°-130°
-----	------	---------	----	----	-----------

Mid-Back Work Chairs

9½"	20½"	24"-29"	8"	4°	103°-130°
-----	------	---------	----	----	-----------

Mid-Back Multi-Use Chairs

9½"	20½"	26"	8"	4°	105°
-----	------	-----	----	----	------

9½"	19½"	23¾"	7½"	4°	105°
-----	------	------	-----	----	------

Rally 457 Series Work Chairs



	Standard Includes	Required to Specify
<ul style="list-style-type: none"> ▶ Need help? Product details, page 138 	<ul style="list-style-type: none"> • Advanced swivel-tilt mechanism • Arms, if selected: plastic color to match base • Outer back and outer seat: plastic • Back tension adjustment • Upholstery: fabric price group 1 • Five-arm base: plastic color • 2½"-diameter, hard composition, dual-wheel casters: plastic color to match base 	<ol style="list-style-type: none"> 1 Style number 2 Plastic color number for base, outer back, outer seat, arms, and casters 3 Fabric color number for upholstery 4 Options, if selected (see below) <ul style="list-style-type: none"> ▶ See <i>Surface Materials</i>, page 248.

	Options	U.S. Price	Required to Specify
Surface Materials	Upholstery		
	• Fabric price group 1	No cost	Specify fabric color number.
	• Fabric price group 2	+\$ 20	Specify fabric color number.
	• Fabric price group 3	+\$ 40	Specify fabric color number.
	• Fabric price group 4	+\$ 55	Specify fabric color number.
	• Fabric price group 5	+\$ 70	Specify fabric color number.
	• Fabric price group 6	+\$100	Specify fabric color number.
	• Fabric price group 7	+\$140	Specify fabric color number.
	• Fabric price group 8	+\$185	Specify fabric color number.
	• Fabric price group 9	+\$220	Specify fabric color number.
	• Fabric price group 10	+\$255	Specify fabric color number.
	• Customer's Own Material (COM)	+\$ 30	▶ See <i>Surface Materials Reference Manual</i> to specify.
• Steelcase leather upholstery	+\$576	Add suffix S to style number and specify leather color number.	
• Customer's Own Leather (COL)	+\$345	Add suffix S to style number.	
		▶ See <i>Surface Materials Reference Manual</i> to specify.	
	• Fire Code Seating (FCS)	+\$ 55	Add suffix F to the style number.
	• Soil-retardant treatment applied to upholstery fabric	+\$ 20	Specify <i>with soil-retardant treatment</i> .
	Fully upholstered		
	• Fabric fully upholstered outer back and outer seat	+\$157	Add suffix U to the style number.
	• Steelcase leather fully upholstered outer back and outer seat	+\$995	Add suffix SU to the style number and specify leather color number.
	• Customer's Own Leather (COL) fully upholstered outer back and outer seat	+\$535	Add suffix SU to the style number.
			▶ See <i>Surface Materials Reference Manual</i> to specify.
Casters	• Soft, dual-wheel casters for use on hard floors (2½")	+\$ 18	Specify <i>with soft casters</i> .

Tip: Always add suffixes in alphabetical order when specifying options to Rally seating.

Tip: Fire Code Seating (FCS) option is available with certain upholstery fabric choices only.
▶ Pages 254–255

▶ Detailed dimensions, page 140

US 

For **164** U.S., multiply all **162** U.S. prices by 1.03.
Multiply **164** U.S. by 1.2 for **138** Canadian price.
▶ See page 1 for details.

Specification Information

With Arms



• **Style Number**
• **U.S. Base Price**

Without Arms



• **Style Number**
• **U.S. Base Price**

High-Back Work Chairs

Pneumatic

4571224	\$794	4571204	\$729
----------------	-------	----------------	-------

Pneumatic with Upright Back Lock

4571424	\$839	4571404	\$774
----------------	-------	----------------	-------

With Arms



• **Style Number**
• **U.S. Base Price**

Without Arms



• **Style Number**
• **U.S. Base Price**

Mid-Back Work Chairs

Pneumatic

4571223	\$741	4571203	\$676
----------------	-------	----------------	-------

Pneumatic with Upright Back Lock

4571423	\$786	4571403	\$721
----------------	-------	----------------	-------

Rally 457 Series

US 

For **164** U.S., multiply all **162** U.S. prices by 1.03.
Multiply **164** U.S. by 1.2 for **138** Canadian price.
▶ See page 1 for details.

Rally 457 Series Mid-Back Multi-Use Chairs



	Standard Includes	Required to Specify
▶ Need help? Product details, page 138	<ul style="list-style-type: none"> Arms, if selected: plastic color to match base Fixed height with swivel-only base Frame and arms on sled-base models: plastic color Outer back and outer seat: plastic Upholstery: fabric price group 1 Five-arm base: plastic color Glides on sled base: plastic 2½"-diameter, hard composition, dual-wheel casters: plastic color to match base 	<ol style="list-style-type: none"> Style number Plastic color number for base, outer back, outer seat, arms, and casters Fabric color number for upholstery Options, if selected (see below) <p>▶ See <i>Surface Materials</i>, page 248.</p>

	Options	U.S. Price	Required to Specify
Surface Materials	Upholstery		
	<ul style="list-style-type: none"> Fabric price group 1 Fabric price group 2 Fabric price group 3 Fabric price group 4 Fabric price group 5 Fabric price group 6 Fabric price group 7 Fabric price group 8 Fabric price group 9 Fabric price group 10 Customer's Own Material (COM) Steelcase leather upholstery Customer's Own Leather (COL) Fire Code Seating (FCS) Soil-retardant treatment applied to upholstery fabric 	<ul style="list-style-type: none"> No cost +\$ 20 +\$ 40 +\$ 55 +\$ 70 +\$100 +\$140 +\$185 +\$220 +\$255 +\$ 30 +\$576 +\$345 +\$ 55 +\$ 20 	<ul style="list-style-type: none"> Specify fabric color number. Specify fabric color number. Specify fabric color number. Specify fabric color number. Specify fabric color number. Specify fabric color number. Specify fabric color number. Specify fabric color number. Specify fabric color number. Specify fabric color number. ▶ See <i>Surface Materials Reference Manual</i> to specify. Add suffix S to style number and specify leather color number. Add suffix S to style number. ▶ See <i>Surface Materials Reference Manual</i> to specify. Add suffix F to the style number. Specify <i>with soil-retardant treatment</i>.
	Fully upholstered		
	<ul style="list-style-type: none"> Fabric fully upholstered outer back and outer seat Steelcase leather fully upholstered outer back and outer seat Customer's Own Leather (COL) fully upholstered outer back and outer seat 	<ul style="list-style-type: none"> +\$157 +\$995 +\$535 	<ul style="list-style-type: none"> Add suffix U to the style number. Add suffix SU to the style number and specify leather color number. Add suffix SU to the style number. ▶ See <i>Surface Materials Reference Manual</i> to specify.
Casters	<ul style="list-style-type: none"> Soft, dual-wheel casters for use on hard floors on side chairs with five-arm base (2½") 	<ul style="list-style-type: none"> +\$ 18 	<ul style="list-style-type: none"> Specify <i>with soft casters</i>.

Tip: Always add suffixes in alphabetical order when specifying options to Rally seating.

Tip: Fire Code Seating (FCS) option is available with certain upholstery fabric choices only.

▶ Pages 254–255

▶ Detailed dimensions, page 140

US 

For **164** U.S., multiply all **162** U.S. prices by 1.03.
 Multiply **164** U.S. by 1.2 for **138** Canadian price.
 ▶ See page 1 for details.

Specification Information

With Arms



• Style
• Number
• U.S.
• Base
• Price

Without Arms



• Style
• Number
• U.S.
• Base
• Price

Mid-Back Multi-Use Chairs

Fixed-Height Swivel Base

4573023	\$671	4573003	\$606
---------	-------	---------	-------

Sled-Base with Arms



• Style
• Number
• U.S.
• Base
• Price

Mid-Back Multi-Use Chairs

Sled-Base

4575023	\$551
---------	-------

US 
For **164** U.S., multiply all
162 U.S. prices by 1.03.
Multiply **164** U.S. by 1.2 for
138 Canadian price.
▶ See page 1 for details.



Understanding and Specifying Protegé 433 Series Work Chairs

Understanding Protegé 433 Series

Details	148
Dimensions	150

Specifying Protegé 433 Series

Value Package Work Chair	152
Work Chairs	154
Multi-Use Chairs	156
Sled-Base Multi-Use Chairs	158

Work Chairs

Adjustable work chairs offer basic ergonomic comfort for people who have varied tasks and tend to be in and out of the office during the day. Features include adjustable seat height, back tension, and upright back lock. Also featured is the no front-rise seat—in other words, when you lean back, the front edge of the seat doesn't rise up, lifting your legs off the floor and cutting off circulation.

- Rally 457 Series
- Protegé 433 Series
- Cachet 487 Series

Adjustability Features

▶ See page 11 for a comparison to other chairs

Protegé 433 Series

Mechanisms

Advanced swivel-tilt	●
----------------------	---

Seat Adjustments

Pneumatic height	●
------------------	---

Back Adjustments

Upright back lock	●
-------------------	---

Back tension	●
--------------	---

Protegé 433 Series

Protegé is an economic, general-use solution with basic ergonomic features. Protegé is stylish, comfortable, and well suited for a wide range of tasks, including moderate computer use.

Outer back is plastic. Fully upholstered outer back is an option.



Five-arm base is standard.

Arms are available without arm caps or with soft vinyl arm caps.

Seat height adjusts with a 5" range from 16"H to 21"H with a pneumatic adjustment mechanism.

Hard, dual-wheel casters are provided for use on carpets. Soft, dual-wheel casters are available for use on hard floors or chair mats.

Product Details



Work and multi-use chairs are available with or without arms.



Multi-use chair bases are available in two styles: advanced swivel-tilt and sled base.

Adjustment Features

Seat Adjustments

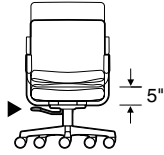

Seat height adjusts pneumatically. To lower, hold handle up while seated. To raise, hold handle up and keep your weight off the chair.

Back Adjustments



Back tension adjusts by turning knob. Turn knob clockwise to increase tension, counterclockwise to decrease.



Upright back lock. Flick switch forward to lock; flick switch back to tilt.



Surface Materials

► See surface materials on page 248 for specific availability or refer to the *Surface Materials Reference Manual* for further information.

Upholstery

- Fabric
- Fabric with soil-retardant treatment (option)
- Leather

Hard components

(base, arms, plastic arm caps, outer back, outer seat, frame, and casters)

- Monochromatic color from list of seating plastic color numbers will apply to all hard components.

Base

- Plastic color to match monochromatic color of other “hard components”

Outer back

- Plastic color to match monochromatic color of other “hard components”
- Fully upholstered

Arms and arm caps

- Plastic color to match monochromatic color of other “hard components”

Glides

- Plastic on sled base models

All Steelcase seating with standard upholstery fabrics complies with requirements of the BIFMA First Generation Voluntary Upholstered Furniture Flammability Standard, as well as the State of California Technical Bulletin 117. All standard seating is labeled to be in compliance with California TB117.

Programs & Services

► See the *Surface Materials Reference Manual* for further detail about programs and services offered for seating.

The Customer's Own Material (COM) Program

offers the opportunity for customers to select fabrics that are not offered through the standard Steelcase surface materials program for use on Steelcase products. Through the COM program, Steelcase will test your materials for application on Steelcase products. Once approved, you can place your order. Steelcase will facilitate the entire ordering process and give you a production schedule. Steelcase will order the COM fabric directly from the textile manufacturer. For up-to-date information regarding fabric test results for all COM fabrics and details regarding yardage requirements for most Seating lines, visit the COM Web site. To locate the COM Web site:

- Visit www.steelcase.com
- Click on “Knowledge & Design”
- Select “Customer's Own Material”

Soil retardants are treatments that provide long-term soil and stain resistance to a fabric without affecting the shade or the integrity of the fabric. The following Steelcase Textiles are available pre-treated with soil retardant. (You do not need to select the soil-retardant option for these fabrics and incur the upcharge.)

- Jacks
- Link
- Regis
- Roulette
- Skittles
- Spyder

Soil-retardant treatment is available on all other seating fabrics at an additional upcharge per seating unit. To order this option, please select “Soil-Retardant Treatment” under “Optional Accessories.”

For soil-retardant treatment on COMs, please select “Soil-Retardant Treatment” under “Optional Accessories.” Minimums or additional yardage may be required. Please contact the vendor directly for specific information.

Extended lead times may be necessary for this service.

Contact your Steelcase Solutions Fulfillment Team Representative at 1.888.STEELCASE (1.888.783.3522).

Fire Codes

► See pages 254–255 for upholstery fabrics available for use with FCS modification.

Steelcase offers Fire Code Seating modification (FCS) on nearly all seating models. The most rigorous fire codes in the nation have been developed in California, and the Steelcase FCS modification is designed to meet those codes. Fire Code Seating (FCS) indicates that a product is constructed to meet the strict fire code requirements of high public occupancy areas such as theaters, meeting rooms, and lobbies. The FCS standards will meet both the State of California Home Furnishing Technical Bulletin 133 (Cal TB 133) and Boston Fire Code (BFC). Boston adopted the California Home Furnishing Technical Bulletin TB 133 test standard in 1992.

Local codes may have special requirements for upholstery.

Dimensions

► Page 150

Resources

- Printed Materials**
- Protegé Brochure (04-0000171)
 - Seating Overview (06-0000890)

Dimensions

Protégé 433 Series

Features	Overall Depth	Width	Height	Seat Depth	Functional Seat Depth	Seat Width	Seat Height from Floor	Back Width	Back Height from Seat
----------	---------------	-------	--------	------------	-----------------------	------------	------------------------	------------	-----------------------

Protégé 433 Series

Work Chairs

Pneumatic	21 1/4"	23"	33 3/4"–38 3/4"	17 1/2"	16"	19 1/2"	16"–21"	19"	19 1/4"
-----------	---------	-----	-----------------	---------	-----	---------	---------	-----	---------

Multi-Use Chairs

Fixed Height	21 1/4"	23"	35 1/4"	17 1/2"	16"	19 1/2"	17 1/4"	19"	19 1/4"
Sled Base	21 1/4"	23"	35"	17 1/2"	16"	19 1/2"	18 1/4"	19"	19 1/4"

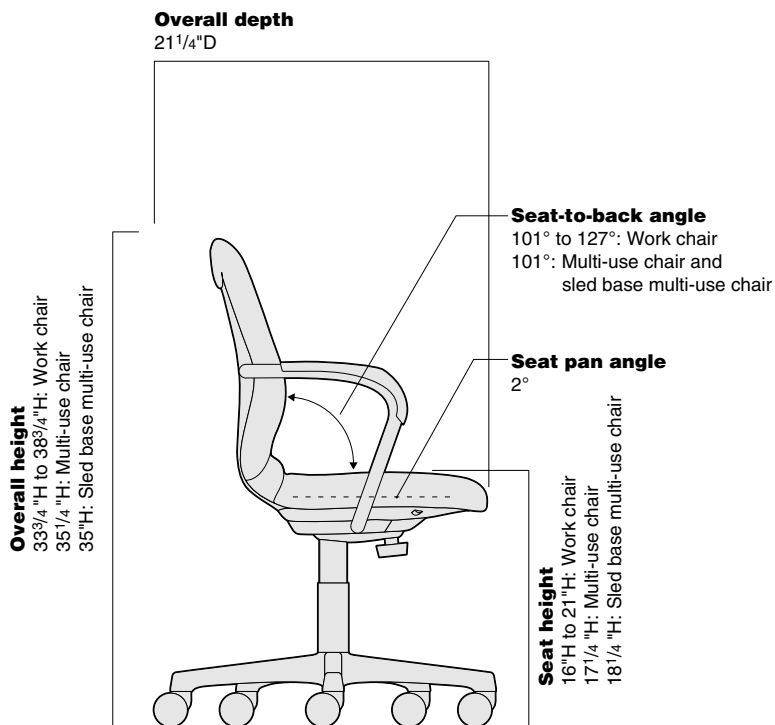
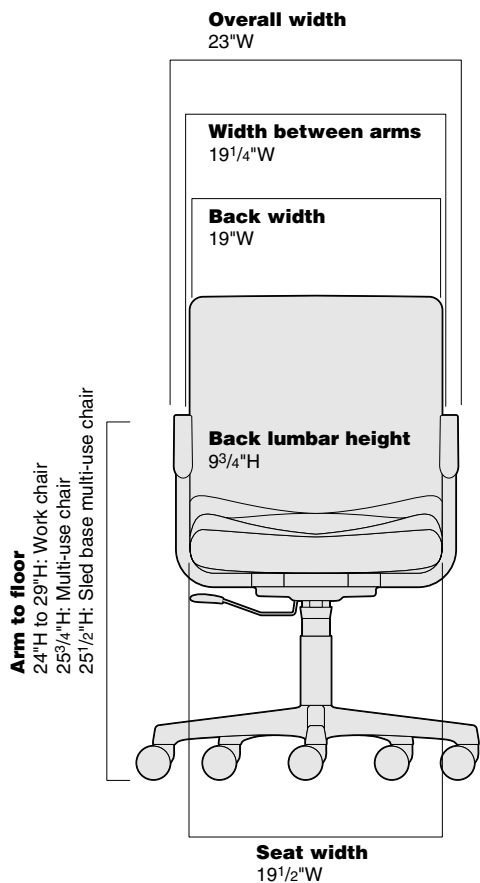

• Back • Lumbar • Height	• Width • Between • Arms	• Arm • to • Floor	• Arm • Height • from • Seat	• Seat • Pan • Angle	• Angle • Between • Seat and • Back
--------------------------------	--------------------------------	--------------------------	---------------------------------------	----------------------------	--

Work Chairs

9¾"	19¼"	24"-29"	7¾"	2°	101°-127°
-----	------	---------	-----	----	-----------

Multi-Use Chairs

9¾"	19¼"	25¾"	7¾"	2°	101°
9¾"	19¼"	25½"	7¾"	2°	101°

Protégé 433 Series Value Package Work Chair

Buzz2 Fabric on Seat and Back
Black Plastic Finish on Frame



Tip: This value package allows you to obtain the pre-selected features at a lower price than if specifying as a standard model number.

Tip: Options or substitutions are not available on this value package.

Standard Includes		Required to Specify
<ul style="list-style-type: none"> ▶ Need help? Product details, page 148 	<ul style="list-style-type: none"> • Advanced swivel-tilt mechanism • Pneumatic seat-height adjustment • Arms with soft arm caps • Back tension adjustment • Seat and back: Buzz2 fabric • Five-arm base: black plastic • Frame: black plastic • Hard dual-wheel casters: black 	<ul style="list-style-type: none"> 1 Style number 2 Buzz2 fabric color number ▶ See <i>Surface Materials</i>, page 248.

Specification Information	
Style Number	U.S. Price
PROTEGEV	\$581
:	:
:	:

▶ Detailed dimensions, page 150

US 

For **164** U.S., multiply all **162** U.S. prices by 1.03.
Multiply **164** U.S. by 1.2 for **138** Canadian price.
▶ See page 1 for details.

Protegé 433 Series Work Chairs



Standard Includes		Required to Specify
<ul style="list-style-type: none"> ▶ Need help? Product details, page 148 	<ul style="list-style-type: none"> • Advanced swivel-tilt mechanism • Arms, if selected: plastic color to match base • Outer back: plastic color • Back tension adjustment • Upholstery: fabric price group 1 • Five-arm base: plastic color • 2½"-diameter, hard composition, dual-wheel casters: plastic color to match base 	<ol style="list-style-type: none"> 1 Style number 2 Plastic color number for base, outer back, arms, and casters 3 Fabric color number for upholstery 4 Options, if selected (see below) <ul style="list-style-type: none"> ▶ See <i>Surface Materials</i>, page 248.

Options	U.S. Price	Required to Specify
<p>Surface Materials</p> <ul style="list-style-type: none"> • Fabric price group 1 • Fabric price group 2 • Fabric price group 3 • Fabric price group 4 • Fabric price group 5 • Fabric price group 6 • Fabric price group 7 • Fabric price group 8 • Fabric price group 9 • Fabric price group 10 • Customer's Own Material (COM) • Steelcase leather upholstery • Customer's Own Leather (COL) 	<ul style="list-style-type: none"> No cost +\$ 20 +\$ 40 +\$ 55 +\$ 70 +\$100 +\$140 +\$185 +\$220 +\$255 +\$ 30 +\$566 +\$335 	<ul style="list-style-type: none"> Specify fabric color number. Specify fabric color number. Specify fabric color number. Specify fabric color number. Specify fabric color number. Specify fabric color number. Specify fabric color number. Specify fabric color number. Specify fabric color number. Specify fabric color number. ▶ See <i>Surface Materials Reference Manual</i> to specify. Add suffix S to style number and specify leather color number. Add suffix S to style number. ▶ See <i>Surface Materials Reference Manual</i> to specify. Add suffix F to the style number. Specify <i>with soil-retardant treatment</i>.
<p>Fully upholstered</p> <ul style="list-style-type: none"> • Fabric fully upholstered outer back and outer seat • Steelcase leather fully upholstered outer back and outer seat • Customer's Own Leather (COL) fully upholstered outer back and outer seat 	<ul style="list-style-type: none"> +\$ 94 +\$982 +\$522 	<ul style="list-style-type: none"> Add suffix U to the style number. Add suffix SU to the style number and specify leather color number. Add suffix SU to the style number. ▶ See <i>Surface Materials Reference Manual</i> to specify.
<p>Casters</p> <ul style="list-style-type: none"> • Soft, dual-wheel casters 	<ul style="list-style-type: none"> +\$ 18 	<ul style="list-style-type: none"> Specify <i>with soft casters</i>.

Tip: Always add suffixes in alphabetical order when specifying options to Protegé seating.

Tip: Fire Code Seating (FCS) option is available with certain upholstery fabric choices only.
▶ Pages 254–255

▶ Detailed dimensions, page 150

US 

For **164** U.S., multiply all **162** U.S. prices by 1.03.
Multiply **164** U.S. by 1.2 for **138** Canadian price.
▶ See page 1 for details.

Specification Information

Arms



•Style
•Number
•U.S.
•Base
•Price

**Arms with
Soft Arm Caps**



•Style
•Number
•U.S.
•Base
•Price

Pneumatic

4331213

\$619

4331223

\$645

Pneumatic with Upright Back Lock

4331413

\$664

4331423

\$690

Without Arms



•Style
•Number
•U.S.
•Base
•Price

Pneumatic

4331203

\$586

Pneumatic with Upright Back Lock

4331403

\$631

US 

For **164** U.S., multiply all **162** U.S. prices by 1.03.
Multiply **164** U.S. by 1.2 for **138** Canadian price.
▶ See page 1 for details.

Protegé 433 Series Multi-Use Chairs



	Standard Includes	Required to Specify
▶ Need help? Product details, page 148	<ul style="list-style-type: none"> Fixed height with advanced swivel-tilt mechanism Arms, if selected: plastic color to match base Outer back: plastic color Back tension adjustment Upholstery: fabric price group 1 Five-arm base: plastic color 2½"-diameter, hard composition, dual-wheel casters: plastic color to match base 	<ol style="list-style-type: none"> Style number Plastic color number for base, outer back, arms, and casters Fabric color number for upholstery Options, if selected (see below) <p>▶ See <i>Surface Materials</i>, page 248.</p>

	Options	U.S. Price	Required to Specify
Surface Materials	Upholstery		
	• Fabric price group 1	No cost	Specify fabric color number.
	• Fabric price group 2	+\$ 20	Specify fabric color number.
	• Fabric price group 3	+\$ 40	Specify fabric color number.
	• Fabric price group 4	+\$ 55	Specify fabric color number.
	• Fabric price group 5	+\$ 70	Specify fabric color number.
	• Fabric price group 6	+\$100	Specify fabric color number.
	• Fabric price group 7	+\$140	Specify fabric color number.
	• Fabric price group 8	+\$185	Specify fabric color number.
	• Fabric price group 9	+\$220	Specify fabric color number.
• Fabric price group 10	+\$255	Specify fabric color number.	
• Customer's Own Material (COM)	+\$ 30	▶ See <i>Surface Materials Reference Manual</i> to specify.	
• Steelcase leather upholstery	+\$566	Add suffix S to style number and specify leather color number.	
• Customer's Own Leather (COL)	+\$335	Add suffix S to style number.	
		▶ See <i>Surface Materials Reference Manual</i> to specify.	
	• Fire Code Seating (FCS)	+\$ 55	Add suffix F to the style number.
	• Soil-retardant treatment applied to upholstery fabric	+\$ 20	Specify <i>with soil-retardant treatment</i> .
	Fully upholstered		
	• Fabric fully upholstered outer back and outer seat	+\$ 94	Add suffix U to the style number.
	• Steelcase leather fully upholstered outer back and outer seat	+\$982	Add suffix SU to the style number and specify leather color number.
	• Customer's Own Leather (COL) fully upholstered outer back and outer seat	+\$522	Add suffix SU to the style number.
			▶ See <i>Surface Materials Reference Manual</i> to specify.
Casters	• Soft, dual-wheel casters	+\$ 18	Specify <i>with soft casters</i> .

Tip: Always add suffixes in alphabetical order when specifying options to Protegé seating.

Tip: Fire Code Seating (FCS) option is available with certain upholstery fabric choices only.
▶ Pages 254–255

▶ Detailed dimensions, page 150

US 

For **164** U.S., multiply all **162** U.S. prices by 1.03.
Multiply **164** U.S. by 1.2 for **138** Canadian price.
▶ See page 1 for details.

Specification Information

Arms



• **Style Number**
:
:
:
:
:

• **U.S. Base Price**
:
:
:
:
:

Arms with Soft Arm Caps



• **Style Number**
:
:
:
:
:

• **U.S. Base Price**
:
:
:
:
:

Multi-Use Chairs

Fixed Height

4333013	\$590	4333023	\$616
:	:	:	:

Without Arms



• **Style Number**
:
:
:
:
:

• **U.S. Base Price**
:
:
:
:
:

Multi-Use Chairs

Fixed Height

4333003	\$557
:	:

US 

For **164** U.S., multiply all **162** U.S. prices by 1.03.
Multiply **164** U.S. by 1.2 for **138** Canadian price.
▶ See page 1 for details.

Understanding and Specifying Cachet 487 Series Work Chairs

Understanding Cachet 487 Series

Details	160
Dimensions	162

Specifying Cachet 487 Series

Swivel-Base Work Chairs	164
Leg-Base Multi-Use Chairs	166
Swivel-Base Stools	168
Cushion Upholstery Packages	170
Accessories	173

Work Chairs

Cachet offers basic ergonomic comfort for people who have varied tasks and tend to be in and out of the office during the day. Features include adjustable seat height and a unique Balanced-Action Rocker (BAR) mechanism that allows users to recline easily without a manual adjustment. Also featured is the no front-rise seat—in other words, when you lean back, the front edge of the seat doesn't rise up, lifting your legs off the floor and cutting off circulation.

- Rally 457 Series
- Protégé 433 Series
- Cachet 487 Series

Adjustability Features

► See page 11 for a comparison to other chairs

Cachet 487 Series

Mechanisms

Balanced Action Rocker (BAR)	●
------------------------------	---

Seat Adjustments

Pneumatic height	●
------------------	---

Back Adjustments

Self adjustments	●
------------------	---

Cachet 487 Series

Cachet chairs are lightweight, extremely comfortable, multipurpose chairs with a unique Balanced-Action Rocker (BAR) mechanism that allows the chair to recline in response to the user's weight.

Flexible, contoured back and seat have parallel slats that conform to individual users.

Nylon injection-molded tubular frame provides strength with minimal weight.

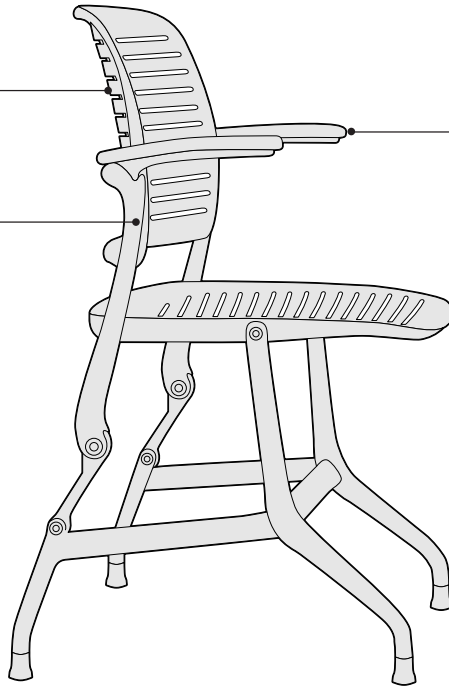

Flip-up arms easily lift to move out of the way or to allow for stacking.

Product Details



Chair bases are available in three styles—fixed-height four leg, adjustable-height swivel, and adjustable-height stool.



Balanced-action rocker (BAR) mechanism allows the user to recline for optimum comfort.

Balanced-action rocker (BAR) mechanism allows every user to fully recline.

Five-arm base is standard.



Seat height adjusts within a 5" range (15½"H to 20½"H) with a pneumatic-adjustment mechanism.

Hard, dual-wheel casters are provided for use on carpets. Soft, dual-wheel casters are available for use on hard floors.

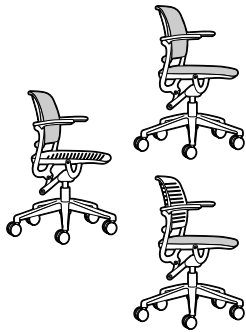

Upholstered cushions are available for use on chair back and seat. Cushions can be specified for factory installation or ordered separately for field installation. When specified with the chair, cushions are available for seat and back, or seat only. When ordered separately, cushions are available for seat and back, seat only, or back only. The cushions attach to the slats of back and seat.

Tip: You must specify plastic outer back color to match chair.

Hard plastic glides are standard on leg-base chairs.

Soft glides are available as an option for use on non-carpeted surfaces. The soft glide is reversible—soft on one side, hard on the other.

Leg-base chairs stack five high on the floor and 20 high on the dolly.

Leg-base chairs are available with or without flip-up arms. Chairs with or without arms can be stacked.

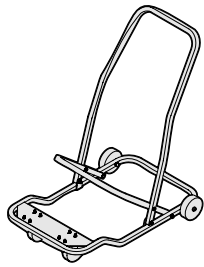

Transport and storage dolly is available to stack, move, and store up to 20 leg-base chairs. Swivel-base chairs will not stack.

Unloaded transport dolly measures 48"D x 23"W x 38³/₄"H.

Fully loaded transport dolly measures 51"D x 23"W x 78³/₄"H.

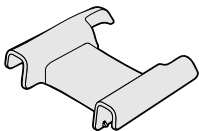

Ganging and alignment device is available to link leg-base chairs together in the field for evenly spaced rows. Chairs can be separated easily. Spacing between chairs linked with alignment device is 2".

Tip: You must specify plastic color of ganging and alignment device to match chairs.

Cachet is recommended for indoor use only.

Surface Materials

► See surface materials on page 248 for specific availability or refer to the *Surface Materials Reference Manual* for further information.

Hard components (frame, flip-up arms, back, seat, and base)

- Swivel and 4-leg chair models available in black, midnight, and ash
- Stool available in black only

Upholstery

- Fabric
- Fabric with soil-retardant treatment (option)
- Leather
- Vinyl

Glides

- Color-matched plastic on leg-base chair
- Color-matched soft plastic on leg-base chair (option)

Casters

- Hard, black plastic wheels on swivel-base chair and stool
- Soft, black plastic wheels (option)

All Steelcase seating with standard upholstery fabrics complies with requirements of the BIFMA First Generation Voluntary Upholstered Furniture Flammability Standard, as well as the State of California Technical Bulletin 117. All standard seating is labeled to be in compliance with California TB117.

Programs & Services

► See the *Surface Materials Reference Manual* for further detail about programs and services offered for seating.

The Customer's Own Material (COM) Program

offers the opportunity for customers to select fabrics that are not offered through the standard Steelcase surface materials program for use on Steelcase products. Through the COM program, Steelcase will test your materials for application on Steelcase products. Once approved, you can place your order. Steelcase will facilitate the entire ordering process and give you a production schedule. Steelcase will order the COM fabric directly from the textile manufacturer. For up-to-date information regarding fabric test results for all COM fabrics and details regarding yardage requirements for most Seating lines, visit the COM Web site. To locate the COM Web site:

- Visit www.steelcase.com
- Click on "Knowledge & Design"
- Select "Customer's Own Material"

Soil retardants are treatments that provide long-term soil and stain resistance to a fabric without affecting the shade or the integrity of the fabric. The following Steelcase Textiles are available pre-treated with soil retardant. (You do not need to select the soil-retardant option for these fabrics and incur the upcharge.)

- Jacks
- Link
- Regis
- Roulette
- Skittles
- Spyder

Soil-retardant treatment is available on all other seating fabrics at an additional upcharge per seating unit. To order this option, please select "Soil-Retardant Treatment" under "Optional Accessories."

For soil-retardant treatment on COMs, please select "Soil-Retardant Treatment" under "Optional Accessories." Minimums or additional yardage may be required. Please contact the vendor directly for specific information.

Extended lead times may be necessary for this service.

Contact your Steelcase Solutions Fulfillment Team Representative at 1.888.STEELCASE (1.888.783.3522).

Fire Codes

► See pages 254–255 for upholstery fabrics available for use with FCS modification.

Fire Code Seating (FCS) option

is available on non-upholstered models. FCS is also available on upholstered models with certain fabric choices only. ► See *Surface Materials*, page 248.

Steelcase offers Fire Code Seating modification (FCS) on nearly all seating models. The most rigorous fire codes in the nation have been developed in California, and the Steelcase FCS modification is designed to meet those codes. Fire Code Seating (FCS) indicates that a product is constructed to meet the strict fire code requirements of high public occupancy areas such as theaters, meeting rooms, and lobbies. The FCS standards will meet both the State of California Home Furnishing Technical Bulletin 133 (Cal TB 133) and Boston Fire Code (BFC). Boston adopted the California Home Furnishing Technical Bulletin TB 133 test standard in 1992.

Local codes may have special requirements for upholstery.

Dimensions

► Page 162

Resources

Printed Materials

- Cachet Product Brochure (04-0011871)
- Anatomy of a Design (S11473)
- Sales and Dealer Guide on in2.steelcase.com
- Seating Overview (06-0000890)

Dimensions

Cachet 487 Series

• Features	• Overall Depth	Width	Height	• Seat Depth	• Functional Seat Depth	• Seat Width*	• Seat Height from Floor	• Back Width	• Back Height from Seat	• Back Lumbar Height
Cachet 487 Series										
Leg-Base Multi-Use Chairs										
Fixed-Height	20½"	23"	34¼"	19¾"	16⅞"	16⅜"	17⅝"	18½"	18¾"	8"
Swivel-Base Work Chairs										
Pneumatic	25"	25"	32⅝"– 37⅞"	19¾"	16⅞"	16⅜"	15½"– 20½"	18½"	18¾"	8"
Stools										
	25"	25"	37⅝"– 44⅞"	19¾"	16⅞"	16⅜"	21"–28¼"	18½"	18¾"	8"

* **Seat width dimension** is taken close to the front edge of the seat. The dimension closer to the actual sitting surface is 19".

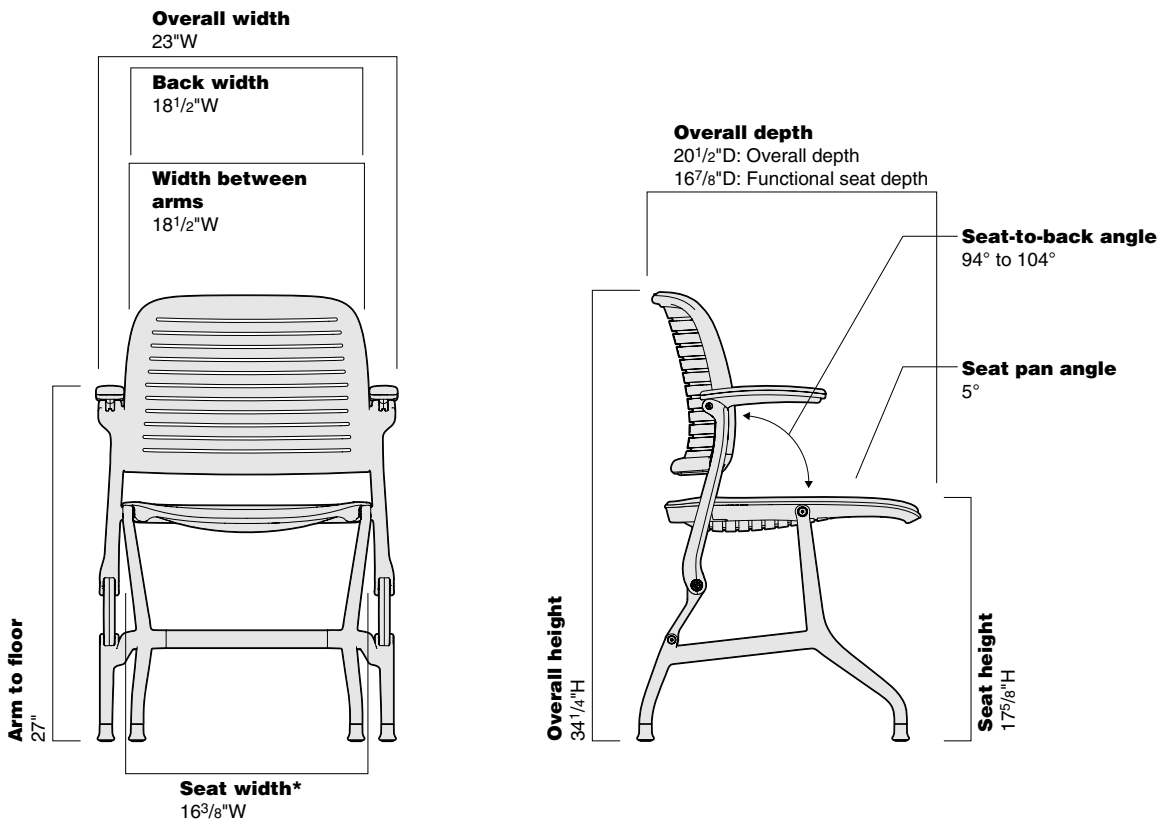

Leg-Base Multi-Use Chair

Width Between Arms	Arm to Floor	Arm Height from Seat	Seat Pan Angle	Angle Between Seat and Back
Leg-Base Multi-Use Chairs				
18½"	27"	10¾"	5°	94°–104°
Swivel-Base Work Chairs				
18½"	25"–30"	10¾"	5°	94°–107°
Stools				
18½"	30"–37¾"	10¾"	5°	94°–107°

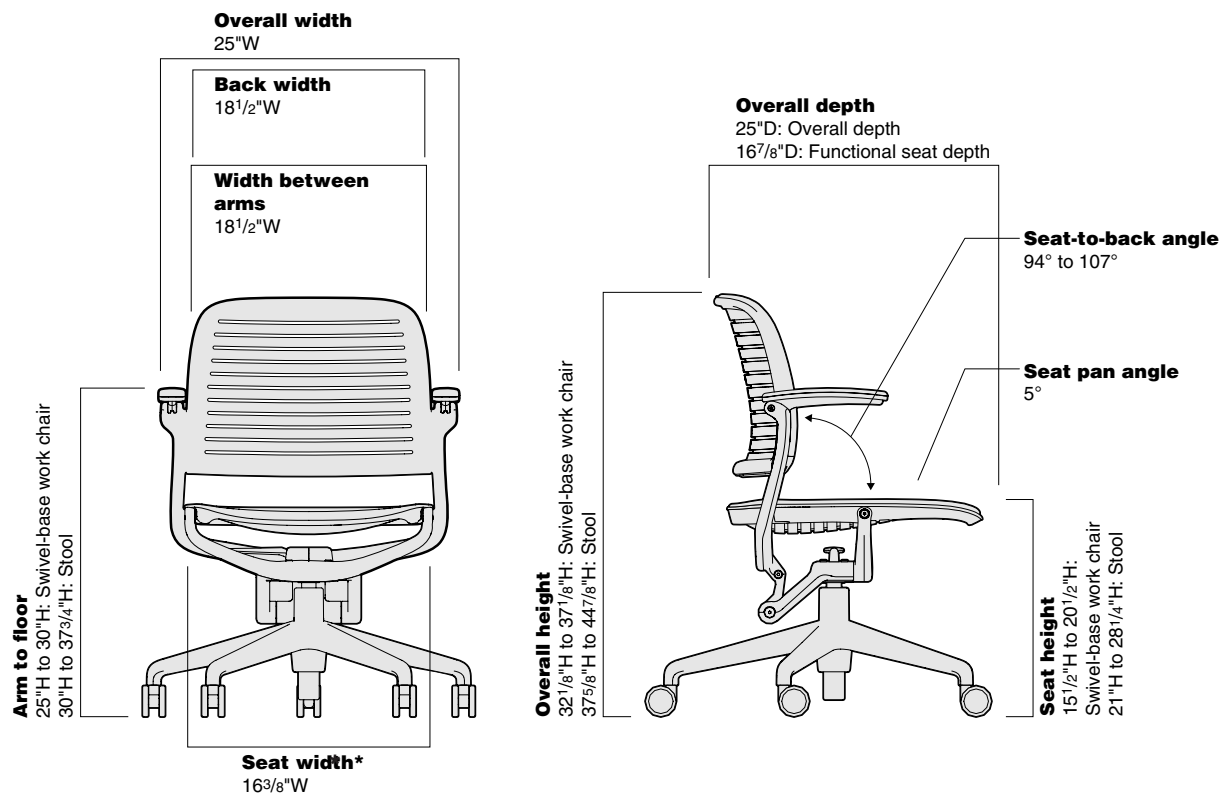

Swivel-Base Work Chair

Cachet 487 Series Swivel-Base Work Chairs



Tip: Fire Code Seating (FCS) option is available on non-upholstered models. FCS is also available on upholstered models with certain fabric choices only.

► Pages 254–255

► Detailed dimensions, page 162

US 

For **164** U.S., multiply all **162** U.S. prices by 1.03.
 Multiply **164** U.S. by 1.2 for **138** Canadian price.
 ► See page 1 for details.

	Standard Includes	Required to Specify
► Need help? Product details, page 160	<ul style="list-style-type: none"> Balanced-action rocker (BAR) mechanism Frame, seat, back, flip-up arms, and five-arm base: plastic 5" pneumatic seat-height adjustment Upholstery, if selected: fabric price group 1 2$\frac{3}{8}$" diameter, hard composition, dual-wheel casters: black plastic 	<ol style="list-style-type: none"> Style number Plastic color number for frame, seat, back, flip-up arms, and five-arm base Fabric color number for upholstery on seat and back, or seat, if selected Options, if selected (see below) ► See <i>Surface Materials</i> , page 248.

	Options	U.S. Price	Required to Specify
Surface Materials	Non-upholstered chair <ul style="list-style-type: none"> Fire Code Seating (FCS) 	+\$ 32	Add suffix F to the style number.
	Upholstery on seat <ul style="list-style-type: none"> Fabric price group 1 Fabric price group 2 Fabric price group 3 Fabric price group 4 Fabric price group 5 Fabric price group 6 Fabric price group 7 Fabric price group 8 Fabric price group 9 Fabric price group 10 Customer's Own Material (COM) Steelcase leather upholstery Customer's Own Leather (COL) Fire Code Seating (FCS) Soil-retardant treatment applied to upholstery fabric 	No cost +\$ 10 +\$ 20 +\$ 28 +\$ 35 +\$ 43 +\$ 50 +\$ 63 +\$ 78 +\$ 88 No cost +\$ 75 No cost +\$ 42 +\$ 20	Specify fabric color number. Specify fabric color number. Specify fabric color number. Specify fabric color number. Specify fabric color number. Specify fabric color number. Specify fabric color number. Specify fabric color number. Specify fabric color number. Specify fabric color number. Specify fabric color number. ► See <i>Surface Materials Reference Manual</i> to specify. Add suffix S to the style number and specify leather color number. Add suffix S to the style number and specify leather color number. ► See <i>Surface Materials Reference Manual</i> to specify. Add suffix F to the style number. Specify <i>with soil-retardant treatment</i> .
	Upholstery on seat and back <ul style="list-style-type: none"> Fabric price group 1 Fabric price group 2 Fabric price group 3 Fabric price group 4 Fabric price group 5 Fabric price group 6 Fabric price group 7 Fabric price group 8 Fabric price group 9 Fabric price group 10 Customer's Own Material (COM) Steelcase leather upholstery Customer's Own Leather (COL) Fire Code Seating (FCS) Soil-retardant treatment applied to upholstery fabric 	No cost +\$ 20 +\$ 40 +\$ 55 +\$ 70 +\$ 85 +\$100 +\$125 +\$155 +\$175 No cost +\$150 No cost +\$ 55 +\$ 20	Specify fabric color number. Specify fabric color number. Specify fabric color number. Specify fabric color number. Specify fabric color number. Specify fabric color number. Specify fabric color number. Specify fabric color number. Specify fabric color number. Specify fabric color number. Specify fabric color number. ► See <i>Surface Materials Reference Manual</i> to specify. Add suffix S to the style number and specify leather color number. Add suffix S to the style number and specify leather color number. ► See <i>Surface Materials Reference Manual</i> to specify. Add suffix F to the style number. Specify <i>with soil-retardant treatment</i> .
Casters	<ul style="list-style-type: none"> Soft, dual-wheel casters for use on hard floors: black plastic 	+\$ 18	Specify <i>with soft casters</i> .

Specification Information

Without Upholstery



Style Number	U.S. Base Price
4871110	\$538

With Upholstered Seat



Style Number	U.S. Base Price
4871210	\$646

With Upholstered Seat and Back



Style Number	U.S. Base Price
4871211	\$699

US 

For **164** U.S., multiply all **162** U.S. prices by 1.03.
 Multiply **164** U.S. by 1.2 for **138** Canadian price.
 ▶ See page 1 for details.

Cachet 487 Series Leg-Base Multi-Use Chairs

Without Arms or with Flip-Up Arms



Tip: Fire Code Seating (FCS) option is available on non-upholstered models. FCS is also available on upholstered models with certain fabric choices only.

▶ Pages 254–255

▶ Detailed dimensions, page 162





For **164** U.S., multiply all **162** U.S. prices by 1.03. Multiply **164** U.S. by 1.2 for **138** Canadian price.
▶ See page 1 for details.

Standard Includes		Required to Specify
▶ Need help? Product details, page 160	<ul style="list-style-type: none"> Balanced-action rocker (BAR) mechanism Frame, seat, back, and four-leg base: plastic Flip-up arms, if selected: plastic color to match frame, seat, and four-leg base Upholstery, if selected: fabric price group 1 Hard glides: color-matched to frame 	<ol style="list-style-type: none"> Style number Plastic color number for frame, seat, back, four-leg base, and flip-up arms, if selected Fabric color number for upholstery on seat and back, or seat, if selected Options, if selected (see below) <p>▶ See <i>Surface Materials</i>, page 248.</p>



Options	U.S. Price	Required to Specify
Surface Materials		
Non-upholstered chair		
• Fire Code Seating (FCS)	+\$ 32	Add suffix F to the style number.
Upholstery on seat		
• Fabric price group 1	No cost	Specify fabric color number.
• Fabric price group 2	+\$ 10	Specify fabric color number.
• Fabric price group 3	+\$ 20	Specify fabric color number.
• Fabric price group 4	+\$ 28	Specify fabric color number.
• Fabric price group 5	+\$ 35	Specify fabric color number.
• Fabric price group 6	+\$ 43	Specify fabric color number.
• Fabric price group 7	+\$ 50	Specify fabric color number.
• Fabric price group 8	+\$ 63	Specify fabric color number.
• Fabric price group 9	+\$ 78	Specify fabric color number.
• Fabric price group 10	+\$ 88	Specify fabric color number.
• Customer's Own Material (COM)	No cost	▶ See <i>Surface Materials Reference Manual</i> to specify.
• Steelcase leather upholstery	+\$ 75	Add suffix S to the style number and specify leather color number.
• Customer's Own Leather (COL)	No cost	Add suffix S to the style number and specify leather color number.
		▶ See <i>Surface Materials Reference Manual</i> to specify.
• Fire Code Seating (FCS)	+\$ 42	Add suffix F to the style number.
• Soil-retardant treatment applied to upholstery fabric	+\$ 20	Specify <i>with soil-retardant treatment</i> .
Upholstery on seat and back		
• Fabric price group 1	No cost	Specify fabric color number.
• Fabric price group 2	+\$ 20	Specify fabric color number.
• Fabric price group 3	+\$ 40	Specify fabric color number.
• Fabric price group 4	+\$ 55	Specify fabric color number.
• Fabric price group 5	+\$ 70	Specify fabric color number.
• Fabric price group 6	+\$ 85	Specify fabric color number.
• Fabric price group 7	+\$100	Specify fabric color number.
• Fabric price group 8	+\$125	Specify fabric color number.
• Fabric price group 9	+\$155	Specify fabric color number.
• Fabric price group 10	+\$175	Specify fabric color number.
• Customer's Own Material (COM)	No cost	▶ See <i>Surface Materials Reference Manual</i> to specify.
• Steelcase leather upholstery	+\$150	Add suffix S to the style number and specify leather color number.
• Customer's Own Leather (COL)	No cost	Add suffix S to the style number and specify leather color number.
		▶ See <i>Surface Materials Reference Manual</i> to specify.
• Fire Code Seating (FCS)	+\$ 55	Add suffix F to the style number.
• Soil-retardant treatment applied to upholstery fabric	+\$ 20	Specify <i>with soil-retardant treatment</i> .
Glides		
• Soft glides: color matched to frame	+\$ 11	Specify <i>with soft glides</i> .

Specification Information

Without Upholstery		With Upholstered Seat		With Upholstered Seat and Back	
					
• Style Number	• U.S. Base Price	• Style Number	• U.S. Base Price	• Style Number	• U.S. Base Price

Without Arms

4878100	\$323	4878200	\$431	4878201	\$484
----------------	-------	----------------	-------	----------------	-------

Without Upholstery		With Upholstered Seat		With Upholstered Seat and Back	
					
• Style Number	• U.S. Base Price	• Style Number	• U.S. Base Price	• Style Number	• U.S. Base Price

With Flip-Up Arms

4878110	\$409	4878210	\$517	4878211	\$570
----------------	-------	----------------	-------	----------------	-------

US 
 For **164** U.S., multiply all **162** U.S. prices by 1.03.
 Multiply **164** U.S. by 1.2 for **138** Canadian price.
 ▶ See page 1 for details.

Cachet 487 Series Swivel-Base Stools



Tip: Fire Code Seating (FCS) option is available on non-upholstered models. FCS is also available on upholstered models with certain fabric choices only.

▶ Pages 254–255

▶ Detailed dimensions, page 162



For **164** U.S., multiply all **162** U.S. prices by 1.03. Multiply **164** U.S. by 1.2 for **138** Canadian price.
▶ See page 1 for details.

Standard Includes		Required to Specify
▶ Need help? Product details, page 160	<ul style="list-style-type: none"> Balanced-action rocker (BAR) mechanism Frame, seat, back, flip-up arms, and five-arm base: black plastic 7¾" pneumatic seat-height adjustment Upholstery, if selected: fabric price group 1 2⅜" diameter, hard composition, dual-wheel casters: black plastic 	<ol style="list-style-type: none"> Style number Fabric color number for upholstery on seat and back, or seat, if selected Options, if selected (see below) <p>▶ See <i>Surface Materials</i>, page 248.</p>

Options	U.S. Price	Required to Specify
Surface Materials		
Non-upholstered chair		
• Fire Code Seating (FCS)	+\$ 32	Add suffix F to the style number.
Upholstery on seat		
• Fabric price group 1	No cost	Specify fabric color number.
• Fabric price group 2	+\$ 10	Specify fabric color number.
• Fabric price group 3	+\$ 20	Specify fabric color number.
• Fabric price group 4	+\$ 28	Specify fabric color number.
• Fabric price group 5	+\$ 35	Specify fabric color number.
• Fabric price group 6	+\$ 43	Specify fabric color number.
• Fabric price group 7	+\$ 50	Specify fabric color number.
• Fabric price group 8	+\$ 63	Specify fabric color number.
• Fabric price group 9	+\$ 78	Specify fabric color number.
• Fabric price group 10	+\$ 88	Specify fabric color number.
• Customer's Own Material (COM)	No cost	▶ See <i>Surface Materials Reference Manual</i> to specify.
• Steelcase leather upholstery	+\$ 75	Add suffix S to the style number and specify leather color number.
• Customer's Own Leather (COL)	No cost	Add suffix S to the style number and specify leather color number.
• Fire Code Seating (FCS)	+\$ 42	▶ See <i>Surface Materials Reference Manual</i> to specify.
• Soil-retardant treatment applied to upholstery fabric	+\$ 20	Add suffix F to the style number. Specify <i>with soil-retardant treatment</i> .
Upholstery on seat and back		
• Fabric price group 1	No cost	Specify fabric color number.
• Fabric price group 2	+\$ 20	Specify fabric color number.
• Fabric price group 3	+\$ 40	Specify fabric color number.
• Fabric price group 4	+\$ 55	Specify fabric color number.
• Fabric price group 5	+\$ 70	Specify fabric color number.
• Fabric price group 6	+\$ 85	Specify fabric color number.
• Fabric price group 7	+\$100	Specify fabric color number.
• Fabric price group 8	+\$125	Specify fabric color number.
• Fabric price group 9	+\$155	Specify fabric color number.
• Fabric price group 10	+\$175	Specify fabric color number.
• Customer's Own Material (COM)	No cost	▶ See <i>Surface Materials Reference Manual</i> to specify.
• Steelcase leather upholstery	+\$150	Add suffix S to the style number and specify leather color number.
• Customer's Own Leather (COL)	No cost	Add suffix S to the style number and specify leather color number.
• Fire Code Seating (FCS)	+\$ 55	▶ See <i>Surface Materials Reference Manual</i> to specify.
• Soil-retardant treatment applied to upholstery fabric	+\$ 20	Add suffix F to the style number. Specify <i>with soil-retardant treatment</i> .
Casters		
• Soft, dual-wheel casters for use on hard floors: black plastic	+\$ 18	Specify <i>with soft casters</i> .

Specification Information

Without Upholstery



• **Style Number**
• **U.S. Base Price**

4877110 \$777

With Upholstered Seat



• **Style Number**
• **U.S. Base Price**

4877210 \$885

With Upholstered Seat and Back



• **Style Number**
• **U.S. Base Price**

4877211 \$938

US 
For **164** U.S., multiply all **162** U.S. prices by 1.03.
Multiply **164** U.S. by 1.2 for **138** Canadian price.
▶ See page 1 for details.

Cushion Upholstery Packages

Cushion Upholstery Package for Back and Seat

for Use on Leg-Base, Swivel, and Stool Models

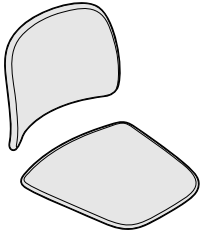

Tip: To comply with FCS requirements, both the chair and the cushion(s) must be specified with the FCS option.

Standard Includes	Required to Specify
-------------------	---------------------

- Package of one seat and one back cushion
- Cushion upholstery for seat and back: fabric price group 1
- Outer back: plastic to match chair

- 1 Style number
 - 2 Fabric color number
 - 3 Specify plastic color of back to match chair
 - 4 Options, if selected (see below)
- ▶ See *Surface Materials*, page 248.

	Options	U.S. Price	Required to Specify
--	---------	------------	---------------------

Surface Materials

- Fabric price group 1 No cost
- Fabric price group 2 +\$ 20
- Fabric price group 3 +\$ 40
- Fabric price group 4 +\$ 55
- Fabric price group 5 +\$ 70
- Fabric price group 6 +\$ 85
- Fabric price group 7 +\$100
- Fabric price group 8 +\$125
- Fabric price group 9 +\$155
- Fabric price group 10 +\$175
- Customer's Own Material (COM) No cost
- Steelcase leather upholstery +\$150
- Customer's Own Leather (COL) No cost
- Fire Code Seating (FCS) +\$ 21
- Soil-retardant treatment +\$ 20

- Specify fabric color number.
- Specify fabric color number.
- Specify fabric color number.
- Specify fabric color number.
- Specify fabric color number.
- Specify fabric color number.
- Specify fabric color number.
- Specify fabric color number.
- Specify fabric color number.
- Specify fabric color number.
- ▶ See *Surface Materials Reference Manual* to specify.
- Add suffix **S** to the style number and specify leather color number.
- Add suffix **S** to the style number and specify leather color number.
- ▶ See *Surface Materials Reference Manual*. Add suffix **F** to the style number.
- Specify *with soil-retardant treatment*.

Specification Information

Style Number	U.S. Base Price

Package of 1 Back Cushion and 1 Seat Cushion

487STBK	\$242
----------------	-------

▶ Detailed dimensions, page 162

US

For **164** U.S., multiply all **162** U.S. prices by 1.03.
 Multiply **164** U.S. by 1.2 for **138** Canadian price.
 ▶ See page 1 for details.

Cushion Upholstery Package for Back

for Use on Leg-Base, Swivel, and Stool Models

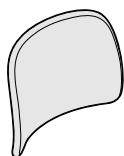

Standard Includes	Required to Specify
<ul style="list-style-type: none"> One back cushion Cushion upholstery for back: fabric price group 1 Outer back: plastic to match chair 	<ol style="list-style-type: none"> Style number Fabric color number for cushion Specify plastic color of back to match chair Options, if selected (see below) <ul style="list-style-type: none"> ▶ See <i>Surface Materials</i>, page 248.

Options	U.S. Price	Required to Specify
Surface Materials <ul style="list-style-type: none"> Fabric price group 1 Fabric price group 2 Fabric price group 3 Fabric price group 4 Fabric price group 5 Fabric price group 6 Fabric price group 7 Fabric price group 8 Fabric price group 9 Fabric price group 10 Customer's Own Material (COM) 	No cost +\$10 +\$20 +\$28 +\$35 +\$43 +\$50 +\$63 +\$78 +\$88 No cost	Specify fabric color number. Specify fabric color number. Specify fabric color number. Specify fabric color number. Specify fabric color number. Specify fabric color number. Specify fabric color number. Specify fabric color number. Specify fabric color number. Specify fabric color number. Specify fabric color number. ▶ See <i>Surface Materials Reference Manual</i> to specify.
<ul style="list-style-type: none"> Steelcase leather upholstery Customer's Own Leather (COL) 	+\$75 No cost	Add suffix S to the style number and specify leather color number. Add suffix S to the style number and specify leather color number. ▶ See <i>Surface Materials Reference Manual</i> .
<ul style="list-style-type: none"> Fire Code Seating (FCS) Soil-retardant treatment 	+\$11 +\$20	Add suffix F to the style number. Specify <i>with soil-retardant treatment</i> .

Tip: To comply with FCS requirements, both the chair and the cushion(s) must be specified with the FCS option.

Specification Information	
Style Number	U.S. Base Price
487BK	\$135

US 

For **164** U.S., multiply all **162** U.S. prices by 1.03.
 Multiply **164** U.S. by 1.2 for **138** Canadian price.
 ▶ See page 1 for details.

Cushion Upholstery Package for Seat

for Use on Leg-Base, Swivel, and Stool Models

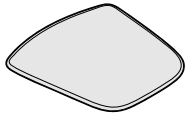

Standard Includes **Required to Specify**

- One seat cushion
- Cushion upholstery for seat: fabric price group 1

- 1 Style number
- 2 Fabric color number for cushion
- 3 Options, if selected (see below)
- ▶ See *Surface Materials*, page 248.

Options **U.S. Price** **Required to Specify**

Surface Materials

- Fabric price group 1 No cost
- Fabric price group 2 +\$10
- Fabric price group 3 +\$20
- Fabric price group 4 +\$28
- Fabric price group 5 +\$35
- Fabric price group 6 +\$43
- Fabric price group 7 +\$50
- Fabric price group 8 +\$63
- Fabric price group 9 +\$78
- Fabric price group 10 +\$88
- Customer's Own Material (COM) No cost

- Steelcase leather upholstery +\$75

- Customer's Own Leather (COL) No cost

- Fire Code Seating (FCS) +\$11
- Soil-retardant treatment +\$20

- Specify fabric color number.
- Specify fabric color number.
- Specify fabric color number.
- Specify fabric color number.
- Specify fabric color number.
- Specify fabric color number.
- Specify fabric color number.
- Specify fabric color number.
- Specify fabric color number.
- Specify fabric color number.
- ▶ See *Surface Materials Reference Manual* to specify.
- Add suffix **S** to the style number and specify leather color number.
- Add suffix **S** to the style number and specify leather color number.
- ▶ See *Surface Materials Reference Manual*.
- Add suffix **F** to the style number.
- Specify *with soil-retardant treatment*.

Tip: To comply with FCS requirements, both the chair and the cushion(s) must be specified with the FCS option.

Specification Information

Style Number	U.S. Base Price
487ST	\$135

▶ Detailed dimensions, page 162

US

For **164** U.S., multiply all **162** U.S. prices by 1.03.
 Multiply **164** U.S. by 1.2 for **138** Canadian price.
 ▶ See page 1 for details.

Transport and Storage Dolly

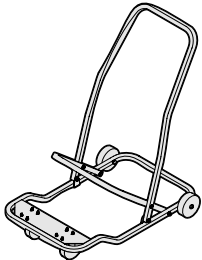

Tip: Transport and storage dolly is for leg-base chairs only.

Standard Includes	Required to Specify
<ul style="list-style-type: none"> ▶ Need help? Product details, page 161 • Transport and storage dolly: black paint only 	<ul style="list-style-type: none"> Style number

Specification Information

Style Number	U.S. Price
487D	\$430
·	·

Ganging and Alignment Devices

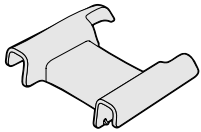

Tip: Ganging and alignment devices are for leg-base chairs only.

Standard Includes	Required to Specify
<ul style="list-style-type: none"> ▶ Need help? Product details, page 161 • Carton of 5 devices: color matched to frame 	<ul style="list-style-type: none"> 1 Style number 2 Plastic color number to match chair ▶ See <i>Surface Materials</i>, page 248.

Specification Information

Style Number	U.S. Price
487G	\$44
·	·

US

For **164** U.S., multiply all **162** U.S. prices by 1.03.
 Multiply **164** U.S. by 1.2 for **138** Canadian price.
 ▶ See page 1 for details.



Understanding and Specifying Ally 463 Series Multi-Use Chairs

Understanding Ally 463 Series

Details	176
Dimensions	178

Specifying Ally 463 Series

Sled-Base Multi-Use Chairs	180
----------------------------	-----

Multi-Use Chairs

Multi-use chairs are suitable for use as occasional seating within team spaces, workstations, offices, or wherever extra seating is required.

- Ally 463 Series
- Player 475 Series
- Move 490 Series
- Snodgrass 474 Series

► For additional multi-use chairs, see page 216.

Ally 463 Series Sled-Base Multi-Use Chair

Ally is a multi-use chair with a flexing frame and pivoting back. The chair stacks and offers exceptional comfort for use in side/guest and team applications.

Arms slope downward and will easily clear the front edge of a worksurface or table. The arms are urethane covered.

Steel frame flexes to give added comfort and is available in monochromatic colors.

Plastic glides with a stainless steel insert are standard.

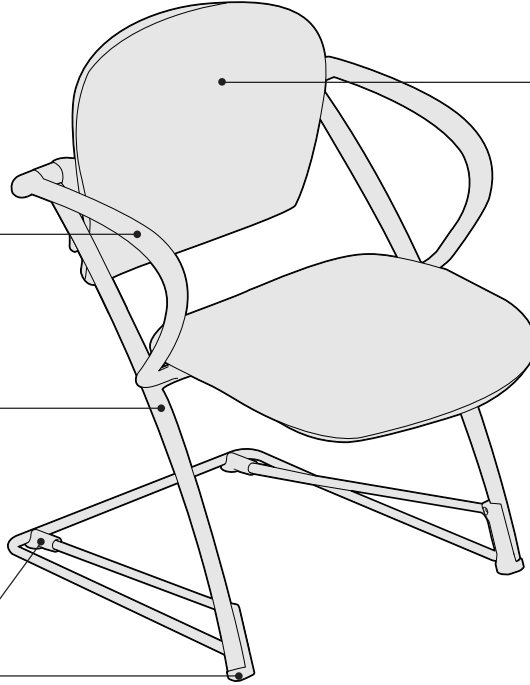

Back pivots for added comfort. Outer back is available in plastic or fully upholstered.

Product Details

Chairs with arms stack three high. Chairs without arms stack four high.

Plastic glides with stainless steel inserts are recommended for carpeted surfaces only.

Soft glides are available for non-carpeted surfaces.

Surface Materials

▶ See surface materials on page 248 for specific availability or refer to the *Surface Materials Reference Manual* for further information.

Upholstery

- Fabric
- Fabric with soil-retardant treatment (option)
- Leather
- Vinyl

Frame

- 6205 Black
 - 6259 Midnight
 - 6296 Sterling
- Outer back, arms, and glides will be Black if you select a Black or Sterling frame. These components will be Midnight if you specify a Midnight frame.

Glides

- Stainless steel

All Steelcase seating with standard upholstery fabrics

complies with requirements of the BIFMA First Generation Voluntary Upholstered Furniture Flammability Standard, as well as the State of California Technical Bulletin 117. All standard seating is labeled to be in compliance with California TB117.

Programs & Services

▶ See the *Surface Materials Reference Manual* for further detail about programs and services offered for seating.

The Customer's Own Material (COM) Program

offers the opportunity for customers to select fabrics that are not offered through the standard Steelcase surface materials program for use on Steelcase products. Through the COM program, Steelcase will test your materials for application on Steelcase products. Once approved, you can place your order. Steelcase will facilitate the entire ordering process and give you a production schedule. Steelcase will order the COM fabric directly from the textile manufacturer. For up-to-date information regarding fabric test results for all COM fabrics and details regarding yardage requirements for most Seating lines, visit the COM Web site. To locate the COM Web site:

- Visit www.steelcase.com
- Click on "Knowledge & Design"
- Select "Customer's Own Material"

Soil retardants are treatments that provide long-term soil and stain resistance to a fabric without affecting the shade or the integrity of the fabric. The following Steelcase Textiles are available pre-treated with soil retardant. (You do not need to select the soil-retardant option for these fabrics and incur the upcharge.)

- Jacks
- Link
- Regis
- Roulette
- Skittles
- Spyder

Soil-retardant treatment is available on all other seating fabrics at an additional upcharge per seating unit. To order this option, please select "Soil-Retardant Treatment" under "Optional Accessories."

For soil-retardant treatment on COMs, please select "Soil-Retardant Treatment" under "Optional Accessories." Minimums or additional yardage may be required. Please contact the vendor directly for specific information.

Extended lead times may be necessary for this service.

Contact your Steelcase Solutions Fulfillment Team Representative at 1.888.STEELCASE (1.888.783.3522).

Fire Codes

▶ See pages 254–255 for upholstery fabrics available for use with FCS modification.

Steelcase offers Fire Code Seating modification (FCS) on nearly all seating models. The most rigorous fire codes in the nation have been developed in California, and the Steelcase FCS modification is designed to meet those codes. Fire Code Seating (FCS) indicates that a product is constructed to meet the strict fire code requirements of high public occupancy areas such as theaters, meeting rooms, and lobbies. The FCS standards will meet both the State of California Home Furnishing Technical Bulletin 133 (Cal TB 133) and Boston Fire Code (BFC). Boston adopted the California Home Furnishing Technical Bulletin TB 133 test standard in 1992.

Local codes may have special requirements for upholstery.

Dimensions

▶ Page 178

Resources

Printed Materials

- ▶ Ally Brochure (S11024)
- ▶ Stackable Seating Brochure (02-0002354)
- ▶ Seating Overview (06-0000890)

Dimensions

Ally 463 Series

Overall Depth	Width	Height	Seat Depth	Functional Seat Depth	Seat Width	Seat Height from Floor	Width Between Arms
Ally 463 Series							
Chair with Arms							
24½"	23¾"	33¾"	20"	17¼"	18⅛"	17¾"	20½"
Chair without Arms							
24½"	21⅛"	33¾"	20"	17¼"	18⅛"	17¾"	20½"

• Back Height from Seat	• Arm Height from Seat	• Arm Height from Floor	• Seat Pan Angle	• Back Width	• Back Lumbar Height	• Angle Between Seat and Back
Chair with Arms						
17½"	9½"	26 ⁵ / ₈ "	3°	18½"	9" to 9¼"	96°
Chair without Arms						
17½"	9½"	26 ⁵ / ₈ "	3°	18½"	9" to 9¼"	96°

Ally 463 Series

Ally 463 Series Sled-Base Multi-Use Chairs



► Need help?
Product details,
page 176

Standard Includes

- Flexing frame: monochromatic color
- Pivoting back
- Upholstery: fabric price group 1
- Arms and glides: 6205 Black arms and glides for 6205 Black and 6296 Sterling frames. 6259 Midnight arms and glides for 6259 Midnight frames.

Required to Specify

- 1 Style number
 - 2 Monochromatic color for frame
 - 3 Fabric color number for upholstery
 - 4 Options, if selected (see below)
- See *Surface Materials*, page 248.

Tip: Always add suffixes in alphabetical order when specifying options to Ally seating.

*Tip: Vinyl is available in a non-sewn version. Specify without the **S** suffix.*

Tip: Fire Code Seating (FCS) option is available with certain upholstery fabric choices only.
► Pages 254–255

Options		U.S. Price	Required to Specify
Surface Materials	Upholstery		
	• Fabric price group 1	No cost	Specify fabric color number.
	• Fabric price group 2	+\$ 20	Specify fabric color number.
	• Fabric price group 3	+\$ 40	Specify fabric color number.
	• Fabric price group 4	+\$ 55	Specify fabric color number.
	• Fabric price group 5	+\$ 70	Specify fabric color number.
	• Fabric price group 6	+\$100	Specify fabric color number.
	• Fabric price group 7	+\$140	Specify fabric color number.
	• Fabric price group 8	+\$185	Specify fabric color number.
	• Fabric price group 9	+\$220	Specify fabric color number.
	• Fabric price group 10	+\$255	Specify fabric color number.
	• Customer's Own Material (COM)	+\$ 30	► See <i>Surface Materials Reference Manual</i> to specify.
	• Steelcase leather upholstery	+\$338	Add suffix S to the style number and specify leather color number.
	• Customer's Own Leather (COL)	+\$108	Add suffix S to the style number and specify leather color number.
	• Steelcase vinyl	+\$108	► See <i>Surface Materials Reference Manual</i> to specify.
	• Fire Code Seating (FCS)	+\$ 55	Add suffix S to the style number and specify vinyl color number.
	• Soil-retardant treatment applied to upholstery fabric	+\$ 20	Add suffix F to the style number.
	Fully upholstered		Specify with soil-retardant treatment.
	• Fabric fully upholstered outer back	+\$ 44	Add suffix U to the style number.
	• Steelcase leather fully upholstered outer back	+\$447	Add suffix SU to the style number and specify leather color number.
	• Customer's Own Leather (COL) fully upholstered outer back	+\$162	Add suffix SU to the style number.
			► See <i>Surface Materials Reference Manual</i> to specify.
Glides	• Soft glides for use on non-carpeted floors	+\$ 6	Specify with soft glides.

Specification Information

With Arms



• **Style Number**

463482

• **U.S. Base Price**

\$464

Without Arms



• **Style Number**

463480

• **U.S. Base Price**

\$396

► Detailed dimensions,
page 178



For **164** U.S., multiply all **162** U.S. prices by 1.03.
Multiply **164** U.S. by 1.2 for **138** Canadian price.
► See page 1 for details.

Understanding and Specifying Player 475 Series Multi-Use Chairs

Understanding Player 475 Series

Details	182
Dimensions	184

Specifying Player 475 Series

Leg-Base Multi-Use Chairs	186
Sled-Base Multi-Use Chairs	190
Leg-Base Stools	194
Accessories	196

Multi-Use Chairs

Multi-use chairs are suitable for use as occasional seating within team spaces, workstations, offices, or wherever extra seating is required.

- Ally 463 Series
- Player 475 Series
- Move 490 Series
- Snodgrass 474 Series

► For additional multi-use chairs, see page 216.

Player 475 Series

Player chairs are guest chairs that also stack. Strength features in the back, arms, and back legs make Player a logical choice for high-traffic areas, and its simple, classic design complements a broad range of work settings.

Arms slope downward and will easily clear the front edge of a worksurface or table. Arms are available in smooth or textured finish.

Steel frame is monochromatic.

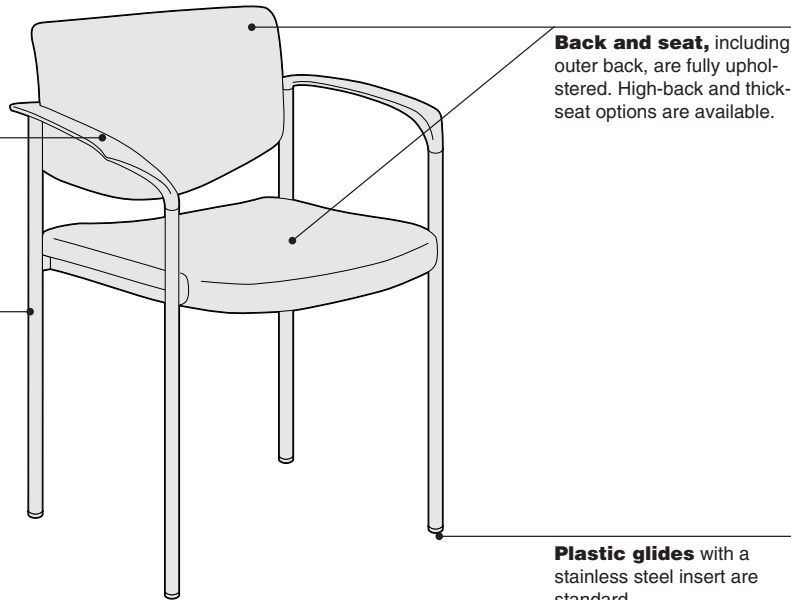

Back and seat, including outer back, are fully upholstered. High-back and thick-seat options are available.

Plastic glides with a stainless steel insert are standard.

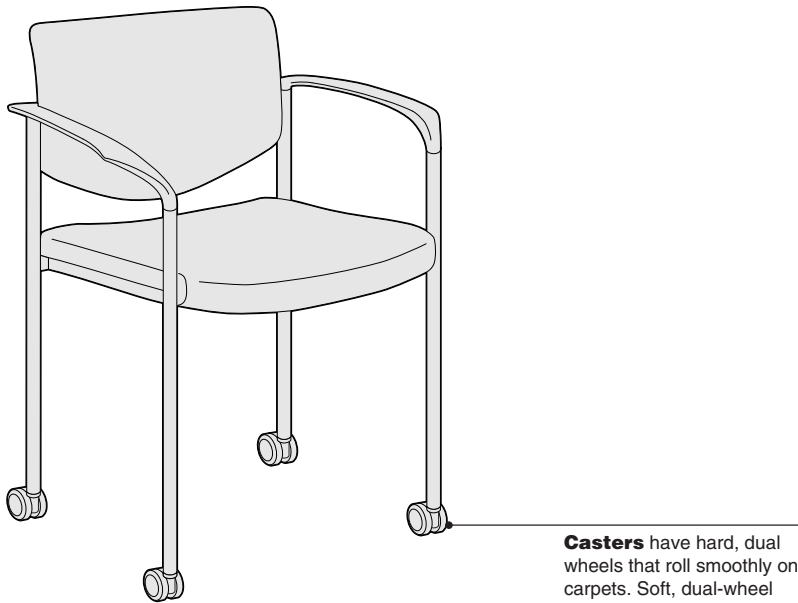

Casters have hard, dual wheels that roll smoothly on carpets. Soft, dual-wheel casters are available for use on hard floor or chair mats. Casters available in black only.

Product Details



Chair models are available with a leg-base or a sled-base. Stools are available with a leg-base. The leg base arms are available with casters. Chairs and stools are available with several features such as arms, tablet arms, bookrack, high back, and thick seat.

Stackability for leg-base models is six high on the floor and eight high on the transport and storage dolly. Leg-base models with casters are not recommended to stack as damage to arms may occur. Sled-base models, stools, and chairs with tablet arms and bookracks will not stack.

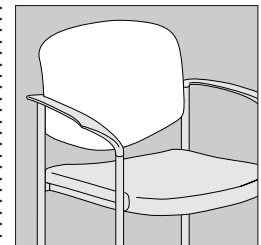

High-back option, available on all Player chairs and stools, adds 2½" to back height. Top edge is slightly rounded. Stackability is not affected.

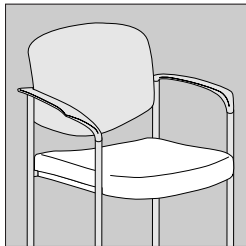

Thick-seat option, available on all Player chairs and stools, increases the thickness of the seat cushion by approximately 1/2". Stackability is not affected.

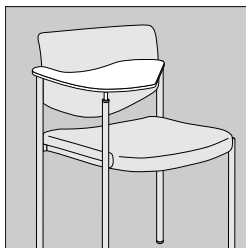

Tablet arm is available right hand and left hand and is shipped knocked down (K.D.). Tablet arm tilts for easy entrance and exit from chair. Tablet arm measures 25 1/2" x 13 1/2". Tablet arm is not available to order separately for installation on existing chairs.

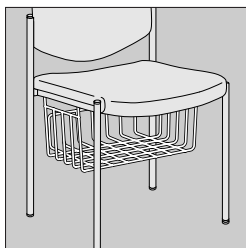

Bookrack is available factory- or field-installed for convenient storage of notebooks and purses. Bookrack measures 10"D x 15 1/2"W x 6"H. Field-installed bookrack will not fit chairs manufactured before January 1, 1994.

Plastic glides, with stainless steel inserts on leg-base Player chairs, are recommended for carpeted surfaces only.

Soft glides are available on Player chairs for non-carpeted surfaces.

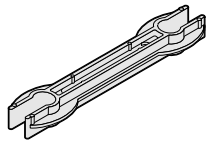

Alignment device is available to temporarily link chairs together for evenly spaced rows. Chairs can be unlinked easily. Spacing between chairs linked with alignment device is 5 7/8".

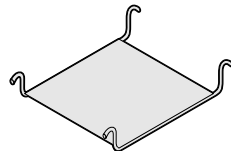

Ganging device is available to link chairs on a more permanent basis. It attaches to the chair's side frame at the same points as a bookrack. Spacing between chairs linked with the ganging device is approximately 9".

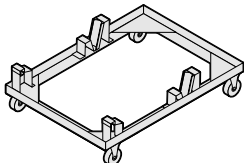

Transport and storage dolly is available to stack, move, and store up to eight chairs with or without arms. Without the dolly, chairs will stack up to six high. Sled-base models, stools, and chairs with tablet arms or bookracks will not stack.

Fully loaded transport dolly measures 32 3/4"D x 25 1/2"W x 55 3/4"H.

Surface Materials

▶ See surface materials on page 248 for specific availability or refer to the *Surface Materials Reference Manual* for further information.

Upholstery

- Fabric
- Fabric with soil-retardant treatment (option)
- Vinyl

Hard components (arms, frames, and sled base)

- Monochromatic color from list of seating plastic color numbers can be applied to all hard components.

Arms

- Smooth plastic
- Textured plastic

Bookrack

- Paint to match the frame color

Tablet arms

- Laminate

Casters

- Black only

Glides

- Plastic with stainless steel inserts

All Steelcase seating with standard upholstery fabrics complies with requirements of the BIFMA First Generation Voluntary Upholstered Furniture Flammability Standard, as well as the State of California Technical Bulletin 117. All standard seating is labeled to be in compliance with California TB117.

Programs & Services

▶ See the *Surface Materials Reference Manual* for further detail about programs and services offered for seating.

The Customer's Own Material (COM) Program

offers the opportunity for customers to select fabrics that are not offered through the standard Steelcase surface materials program for use on Steelcase products. Through the COM program, Steelcase will test your materials for application on Steelcase products. Once approved, you can place your order. Steelcase will facilitate the entire ordering process and give you a production schedule. Steelcase will order the COM fabric directly from the textile manufacturer. For up-to-date information regarding fabric test results for all COM fabrics and details regarding yardage requirements for most Seating lines, visit the COM Web site. To locate the COM Web site:

- Visit www.steelcase.com
- Click on "Knowledge & Design"
- Select "Customer's Own Material"

Soil retardants are treatments that provide long-term soil and stain resistance to a fabric without affecting the shade or the integrity of the fabric. The following Steelcase Textiles are available pre-treated with soil retardant. (You do not need to select the soil-retardant option for these fabrics and incur the upcharge.)

- Jacks
- Link
- Regis
- Roulette
- Skittles
- Spyder

Soil-retardant treatment is available on all other seating fabrics at an additional upcharge per seating unit. To order this option, please select "Soil-Retardant Treatment" under "Optional Accessories."

For soil-retardant treatment on COMs, please select "Soil-Retardant Treatment" under "Optional Accessories." Minimums or additional yardage may be required. Please contact the vendor directly for specific information.

Extended lead times may be necessary for this service.

Contact your Steelcase Solutions Fulfillment Team Representative at 1.888.STEELCASE (1.888.783.3522).

Fire Codes

▶ See pages 254–255 for upholstery fabrics available for use with FCS modification.

Steelcase offers Fire Code Seating modification (FCS) on nearly all seating models. The most rigorous fire codes in the nation have been developed in California, and the Steelcase FCS modification is designed to meet those codes. Fire Code Seating (FCS) indicates that a product is constructed to meet the strict fire code requirements of high public occupancy areas such as theaters, meeting rooms, and lobbies. The FCS standards will meet both the State of California Home Furnishing Technical Bulletin 133 (Cal TB 133) and Boston Fire Code (BFC). Boston adopted the California Home Furnishing Technical Bulletin TB 133 test standard in 1992.

Local codes may have special requirements for upholstery.

Dimensions

▶ Page 184

Resources

- Printed Materials**
- ▶ Player Brochure (S11349)
 - ▶ Stackable Seating Brochure (02-0002354)
 - ▶ Seating Overview (06-0000890)

Dimensions

Player 475 Series

• Features	• Overall Depth	Width	Height	• Seat Depth	• Functional Seat Depth	• Seat Width	• Seat Height from Floor	• Back Width	• Back Height from Seat
Player 475 Series									
Leg-Base Chair with Arms									
	21¼"	25½"	30¼"	19¾"	17½"	18¼"	18¼"	18½"	13¾"
Leg-Base Chair without Arms									
	21¼"	20"	30¼"	19¾"	17½"	18¼"	18¼"	18½"	13¾"
Sled-Base Chair with Arms									
	21¼"	25½"	30¼"	19¾"	17½"	18¼"	18"	18½"	13¾"
Sled-Base Chair without Arms									
	21¼"	20"	30¼"	19¾"	17½"	18¼"	18"	18½"	13¾"
Leg-Base Stool with Arms									
	21¼"	25½"	42"	19¾"	17½"	18¼"	29½"	18½"	13¾"
Leg-Base Stool without Arms									
	21¼"	20"	42"	19¾"	17½"	18¼"	29½"	18½"	13¾"

• Back Lumbar Height	• Width Between Arms	• Arm to Floor	• Arm Height from Seat	• Seat Pan Angle	• Angle Between Seat and Back
----------------------	----------------------	----------------	------------------------	------------------	-------------------------------

Leg-Base Chair with Arms

7¼"	20½"	25¼"	8¾"	4°	95°
-----	------	------	-----	----	-----

Leg-Base Chair without Arms

7¼"	N.A.	N.A.	N.A.	4°	95°
-----	------	------	------	----	-----

Sled-Base Chair with Arms

7¼"	20½"	25¼"	8¾"	4°	95°
-----	------	------	-----	----	-----

Sled-Base Chair without Arms

7¼"	N.A.	N.A.	N.A.	4°	95°
-----	------	------	------	----	-----

Leg-Base Stool with Arms

7¼"	20½"	36½"	8¾"	4°	95°
-----	------	------	-----	----	-----

Leg-Base Stool without Arms

7¼"	N.A.	N.A.	N.A.	4°	95°
-----	------	------	------	----	-----

Player 475 Series Leg-Base Multi-Use Chairs

with Open Arms or without Arms



Tip: Color choices are limited for chairs with textured plastic arms.

▶ Page 256

Tip: Fire Code Seating (FCS) option is available with certain upholstery fabric choices only.

▶ Pages 254–255

Standard Includes		Required to Specify
▶ Need help? Product details, page 182	<ul style="list-style-type: none"> • Frame: monochromatic color • Arms, if selected: plastic color to match frame color • Upholstery: fabric price group 1 • Bookrack, if selected: will match frame color • Glides, if selected: plastic with stainless steel inserts • Hard composition, dual-wheel casters, if selected; black 	<ol style="list-style-type: none"> 1 Style number 2 Monochromatic color number from seating plastic colors for frame 3 Fabric color number for upholstery 4 Options, if selected (see below) <p>▶ See <i>Surface Materials</i>, page 248.</p>

Options		U.S. Price	Required to Specify
Surface Materials	Upholstery		
	<ul style="list-style-type: none"> • Fabric price group 1 • Fabric price group 2 • Fabric price group 3 • Fabric price group 4 • Fabric price group 5 • Fabric price group 6 • Fabric price group 7 • Fabric price group 8 • Fabric price group 9 • Fabric price group 10 • Customer's Own Material (COM) • Fire Code Seating (FCS) • Soil-retardant treatment applied to upholstery fabric 	<ul style="list-style-type: none"> No cost +\$ 20 +\$ 40 +\$ 55 +\$ 70 +\$100 +\$140 +\$185 +\$220 +\$255 +\$ 30 +\$ 55 +\$ 20 	<ul style="list-style-type: none"> Specify fabric color number. Specify fabric color number. Specify fabric color number. Specify fabric color number. Specify fabric color number. Specify fabric color number. Specify fabric color number. Specify fabric color number. Specify fabric color number. Specify fabric color number. ▶ See <i>Surface Materials Reference Manual</i> to specify. Add suffix F to the style number. Specify <i>with soil-retardant treatment</i>.
Back and Seat	<ul style="list-style-type: none"> • High back • Thick seat • High back and thick seat 	<ul style="list-style-type: none"> +\$ 30 +\$ 30 +\$ 60 	<ul style="list-style-type: none"> Specify <i>with high back</i>. Specify <i>with thick seat</i>. Specify <i>with high back and thick seat</i>.
Glides	<ul style="list-style-type: none"> • Soft glides for use on non-carpeted floors 	<ul style="list-style-type: none"> +\$ 6 	<ul style="list-style-type: none"> Specify <i>with soft glides</i>.
Casters	<ul style="list-style-type: none"> • Soft, dual-wheel casters for use on hard floors 	<ul style="list-style-type: none"> +\$ 18 	<ul style="list-style-type: none"> Specify <i>with soft casters</i>.

▶ Detailed dimensions,
page 184



For **164** U.S., multiply all **162** U.S. prices by 1.03.
Multiply **164** U.S. by 1.2 for **138** Canadian price.
▶ See page 1 for details.

Specification Information

Style Number	U.S. Base Price
--------------	-----------------

Smooth Plastic Arms

With Glides

475412M	\$301
----------------	-------

With Glides and Bookrack

475412MB	\$366
-----------------	-------

With Casters

475412MC	\$342
-----------------	-------

Textured Plastic Arms

With Glides

475415M	\$301
----------------	-------

With Glides and Bookrack

475415MB	\$366
-----------------	-------

With Casters

475415MC	\$342
-----------------	-------

Without Arms

With Glides

475410M	\$276
----------------	-------

With Glides and Bookrack

475410MB	\$341
-----------------	-------



Player 475 Series Leg-Base Multi-Use Chairs

with Tablet Arm



Standard Includes		Required to Specify
<ul style="list-style-type: none"> ▶ Need help? Product details, page 182 	<ul style="list-style-type: none"> • Frame: monochromatic color • Tablet arm: laminate • Upholstery: fabric price group 1 • Bookrack, if selected: will match frame color • Glides: plastic with stainless steel inserts 	<ol style="list-style-type: none"> 1 Style number 2 Monochromatic color number from seating plastic colors for frame 3 Fabric color number for upholstery 4 Laminate color number for tablet arm 5 Options, if selected (see below) <ul style="list-style-type: none"> ▶ See <i>Surface Materials</i>, page 248.

Options	U.S. Price	Required to Specify
Surface Materials	Upholstery <ul style="list-style-type: none"> • Fabric price group 1 No cost • Fabric price group 2 +\$ 20 • Fabric price group 3 +\$ 40 • Fabric price group 4 +\$ 55 • Fabric price group 5 +\$ 70 • Fabric price group 6 +\$100 • Fabric price group 7 +\$140 • Fabric price group 8 +\$185 • Fabric price group 9 +\$220 • Fabric price group 10 +\$255 • Customer's Own Material (COM) +\$ 30 • Fire Code Seating (FCS) +\$ 55 • Soil-retardant treatment applied to upholstery fabric +\$ 20 	<ul style="list-style-type: none"> Specify fabric color number. Specify fabric color number. Specify fabric color number. Specify fabric color number. Specify fabric color number. Specify fabric color number. Specify fabric color number. Specify fabric color number. Specify fabric color number. ▶ See <i>Surface Materials Reference Manual</i> to specify. Add suffix F to the style number. Specify <i>with soil-retardant treatment</i>.
Back and Seat	<ul style="list-style-type: none"> • High back +\$ 30 • Thick seat +\$ 30 • High back and thick seat +\$ 60 	<ul style="list-style-type: none"> Specify <i>with high back</i>. Specify <i>with thick seat</i>. Specify <i>with high back and thick seat</i>.
Glides	<ul style="list-style-type: none"> • Soft glides for use on non-carpeted floors +\$ 6 	<ul style="list-style-type: none"> Specify <i>with soft glides</i>.

Tip: Fire Code Seating (FCS) option is available with certain upholstery fabric choices only.
▶ Pages 254–255

▶ Detailed dimensions, page 184



For **164** U.S., multiply all **162** U.S. prices by 1.03.
Multiply **164** U.S. by 1.2 for **138** Canadian price.
▶ See page 1 for details.

Specification Information

Style Number	U.S. Base Price
--------------	-----------------



Right-Hand Tablet Arm

475410MTR \$431



With Bookrack

475410MTRB \$496



Left-Hand Tablet Arm

475410MTL \$431



With Bookrack

475410MTLB \$496

US 
 For **164** U.S., multiply all **162** U.S. prices by 1.03.
 Multiply **164** U.S. by 1.2 for **138** Canadian price.
 ▶ See page 1 for details.

Player 475 Series Sled-Base Multi-Use Chairs

with Open Arms or without Arms



Tip: Color choices are limited for chairs with textured plastic arms.

▶ Page 256

Tip: Fire Code Seating (FCS) option is available with certain upholstery fabric choices only.

▶ Pages 254–255

Standard Includes		Required to Specify
▶ Need help? Product details, page 182	<ul style="list-style-type: none"> • Frame: monochromatic color • Arms, if selected: plastic color to match frame color • Upholstery: fabric price group 1 • Bookrack, if selected: will match frame color • Glides: plastic with stainless steel inserts 	<ol style="list-style-type: none"> 1 Style number 2 Monochromatic color number from seating plastic colors for frame 3 Fabric color number for upholstery 4 Options, if selected (see below) <p>▶ See <i>Surface Materials</i>, page 248.</p>

Options	U.S. Price	Required to Specify
Surface Materials <ul style="list-style-type: none"> • Fabric price group 1 • Fabric price group 2 • Fabric price group 3 • Fabric price group 4 • Fabric price group 5 • Fabric price group 6 • Fabric price group 7 • Fabric price group 8 • Fabric price group 9 • Fabric price group 10 • Customer's Own Material (COM) • Fire Code Seating (FCS) • Soil-retardant treatment applied to upholstery fabric 	<ul style="list-style-type: none"> No cost +\$ 20 +\$ 40 +\$ 55 +\$ 70 +\$100 +\$140 +\$185 +\$220 +\$255 +\$ 30 +\$ 55 +\$ 20 	<ul style="list-style-type: none"> Specify fabric color number. Specify fabric color number. Specify fabric color number. Specify fabric color number. Specify fabric color number. Specify fabric color number. Specify fabric color number. Specify fabric color number. Specify fabric color number. Specify fabric color number. <p>▶ See <i>Surface Materials Reference Manual</i> to specify.</p> <p>Add suffix F to the style number.</p> <p>Specify <i>with soil-retardant treatment</i>.</p>
Back and Seat <ul style="list-style-type: none"> • High back • Thick seat • High back and thick seat 	<ul style="list-style-type: none"> +\$ 30 +\$ 30 +\$ 60 	<ul style="list-style-type: none"> Specify <i>with high back</i>. Specify <i>with thick seat</i>. Specify <i>with high back and thick seat</i>.
Glides <ul style="list-style-type: none"> • Soft glides for use on non-carpeted floors 	<ul style="list-style-type: none"> +\$ 6 	<ul style="list-style-type: none"> Specify <i>with soft glides</i>.

▶ Detailed dimensions, page 184



For **164** U.S., multiply all **162** U.S. prices by 1.03. Multiply **164** U.S. by 1.2 for **138** Canadian price.
▶ See page 1 for details.

Specification Information

Style Number	U.S. Base Price
--------------	-----------------



Smooth Plastic Arms

475482M	\$389
----------------	-------



With Bookrack

475482MB	\$454
-----------------	-------



Textured Plastic Arms

475485M	\$389
----------------	-------



With Bookrack

475485MB	\$454
-----------------	-------



Without Arms

475480M	\$364
----------------	-------



With Bookrack

475480MB	\$429
-----------------	-------

Player 475 Series

US 

For **164** U.S., multiply all **162** U.S. prices by 1.03.
 Multiply **164** U.S. by 1.2 for **138** Canadian price.
 ▶ See page 1 for details.

Player 475 Series Sled-Base Multi-Use Chairs

with Tablet Arm



Standard Includes		Required to Specify
<ul style="list-style-type: none"> ▶ Need help? Product details, page 182 	<ul style="list-style-type: none"> • Frame: monochromatic color • Tablet arm: laminate • Upholstery: fabric price group 1 • Bookrack, if selected: will match frame color • Glides: stainless steel 	<ol style="list-style-type: none"> 1 Style number 2 Monochromatic color number from seating plastic colors for frame 3 Fabric color number for upholstery 4 Laminate color number for tablet arm 5 Options, if selected (see below) <ul style="list-style-type: none"> ▶ See <i>Surface Materials</i>, page 248.

Options	U.S. Price	Required to Specify
Surface Materials	Upholstery <ul style="list-style-type: none"> • Fabric price group 1 No cost • Fabric price group 2 +\$ 20 • Fabric price group 3 +\$ 40 • Fabric price group 4 +\$ 55 • Fabric price group 5 +\$ 70 • Fabric price group 6 +\$100 • Fabric price group 7 +\$140 • Fabric price group 8 +\$185 • Fabric price group 9 +\$220 • Fabric price group 10 +\$255 • Customer's Own Material (COM) +\$ 30 • Fire Code Seating (FCS) +\$ 55 • Soil-retardant treatment applied to upholstery fabric +\$ 20 	<ul style="list-style-type: none"> Specify fabric color number. Specify fabric color number. Specify fabric color number. Specify fabric color number. Specify fabric color number. Specify fabric color number. Specify fabric color number. Specify fabric color number. Specify fabric color number. ▶ See <i>Surface Materials Reference Manual</i> to specify. Add suffix F to the style number. Specify <i>with soil-retardant treatment</i>.
Back and Seat	<ul style="list-style-type: none"> • High back +\$ 30 • Thick seat +\$ 30 • High back and thick seat +\$ 60 	<ul style="list-style-type: none"> Specify <i>with high back</i>. Specify <i>with thick seat</i>. Specify <i>with high back and thick seat</i>.
Glides	<ul style="list-style-type: none"> • Soft glides for use on non-carpeted floors +\$ 6 	<ul style="list-style-type: none"> Specify <i>with soft glides</i>.

Tip: Fire Code Seating (FCS) option is available with certain upholstery fabric choices only.
▶ Pages 254–255

▶ Detailed dimensions, page 184

US 

For **164** U.S., multiply all **162** U.S. prices by 1.03.
Multiply **164** U.S. by 1.2 for **138** Canadian price.
▶ See page 1 for details.

Specification Information

Style Number	U.S. Base Price
--------------	-----------------



Right-Hand Tablet Arm

475480MTR	\$519
------------------	-------



With Bookrack

475480MTRB	\$584
-------------------	-------



Left-Hand Tablet Arm

475480MTL	\$519
------------------	-------



With Bookrack

475480MTLB	\$584
-------------------	-------



For **164** U.S., multiply all **162** U.S. prices by 1.03. Multiply **164** U.S. by 1.2 for **138** Canadian price.
▶ See page 1 for details.

Player 475 Series Leg-Base Stools



Tip: Color choices are limited for chairs with textured plastic arms.
▶ Page 256

Tip: Fire Code Seating (FCS) option is available with certain upholstery fabric choices only.
▶ Pages 254–255

Standard Includes	Required to Specify
<ul style="list-style-type: none"> ▶ Need help? Product details, page 182 • Frame: monochromatic color • Arms, if selected: plastic color to match frame color • Upholstery: fabric price group 1 • Bookrack, if selected: monochromatic match frame • Glides: plastic with stainless steel inserts 	<ol style="list-style-type: none"> 1 Style number 2 Monochromatic color number from seating plastic colors for frame 3 Fabric color number for upholstery 4 Options, if selected (see below) <p>▶ See <i>Surface Materials</i>, page 248.</p>

Options	U.S. Price	Required to Specify
<p>Surface Materials</p> <ul style="list-style-type: none"> • Fabric price group 1 • Fabric price group 2 • Fabric price group 3 • Fabric price group 4 • Fabric price group 5 • Fabric price group 6 • Fabric price group 7 • Fabric price group 8 • Fabric price group 9 • Fabric price group 10 • Customer's Own Material (COM) • Fire Code Seating (FCS) • Soil-retardant treatment applied to upholstery fabric 	<p>No cost</p> <p>+\$ 20</p> <p>+\$ 40</p> <p>+\$ 55</p> <p>+\$ 70</p> <p>+\$100</p> <p>+\$140</p> <p>+\$185</p> <p>+\$220</p> <p>+\$255</p> <p>+\$ 30</p> <p>+\$ 55</p> <p>+\$ 20</p>	<p>Specify fabric color number.</p> <p>Specify fabric color number.</p> <p>Specify fabric color number.</p> <p>Specify fabric color number.</p> <p>Specify fabric color number.</p> <p>Specify fabric color number.</p> <p>Specify fabric color number.</p> <p>Specify fabric color number.</p> <p>Specify fabric color number.</p> <p>Specify fabric color number.</p> <p>▶ See <i>Surface Materials Reference Manual</i> to specify.</p> <p>Add suffix F to the style number.</p> <p>Specify <i>with soil-retardant treatment</i>.</p>
<p>Back and Seat</p> <ul style="list-style-type: none"> • High back • Thick seat • High back and thick seat 	<p>+\$ 30</p> <p>+\$ 30</p> <p>+\$ 60</p>	<p>Specify <i>with high back</i>.</p> <p>Specify <i>with thick seat</i>.</p> <p>Specify <i>with high back and thick seat</i>.</p>
<p>Glides</p> <ul style="list-style-type: none"> • Soft glides for use on non-carpeted floors 	<p>+\$ 6</p>	<p>Specify <i>with soft glides</i>.</p>

▶ Detailed dimensions, page 184

US 

For **164** U.S., multiply all **162** U.S. prices by 1.03.
Multiply **164** U.S. by 1.2 for **138** Canadian price.
▶ See page 1 for details.

Specification Information

Style Number	U.S. Base Price
--------------	-----------------



Smooth Plastic Arms

475712M	\$519
----------------	-------



With Bookrack

475712MB	\$584
-----------------	-------



Textured Plastic Arms

475715M	\$519
----------------	-------



With Bookrack

475715MB	\$584
-----------------	-------



Without Arms

475710M	\$494
----------------	-------



With Bookrack

475710MB	\$559
-----------------	-------

US 
 For **164** U.S., multiply all **162** U.S. prices by 1.03.
 Multiply **164** U.S. by 1.2 for **138** Canadian price.
 ▶ See page 1 for details.

Player 475 Series Accessories

Bookrack

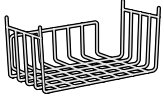

Standard Includes	Required to Specify
<ul style="list-style-type: none"> Bookrack: monochromatic color 	<ul style="list-style-type: none"> 1 Style number 2 Monochromatic color number from seating plastic colors for bookrack ▶ See <i>Surface Materials</i>, page 248.

Specification Information	
Style Number	U.S. Price
475B	\$59
:	:

Alignment Device

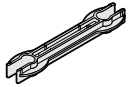

Tip: One pair is required to align two chairs.

Standard Includes	Required to Specify
<ul style="list-style-type: none"> Alignment device: black paint only Package of 5 pairs 	<ul style="list-style-type: none"> Style number

Specification Information	
Style Number	U.S. Price
475A	\$58
:	:

Ganging Device

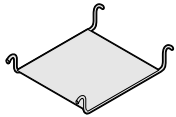

Tip: Use one ganging device for every two chairs.

Standard Includes	Required to Specify
<ul style="list-style-type: none"> Ganging device: black paint only Package of 2 	<ul style="list-style-type: none"> Style number

Specification Information	
Style Number	U.S. Price
475G	\$73
:	:

US

For **164** U.S., multiply all **162** U.S. prices by 1.03.
 Multiply **164** U.S. by 1.2 for **138** Canadian price.
 ▶ See page 1 for details.

Transport and Storage Dolly

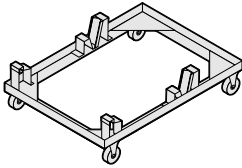

Standard Includes

- Transport and storage dolly: black paint only

Required to Specify

- Style number

Specification Information

• Style Number	• U.S. Price
475D	\$242
.	.

US 

For **164** U.S., multiply all **162** U.S. prices by 1.03.
Multiply **164** U.S. by 1.2 for **138** Canadian price.
▶ See page 1 for details.



Understanding and Specifying Move 490 Series Multi-Use Chairs

Understanding Move 490 Series

Details	200
Dimensions	202

Specifying Move 490 Series

Value Package Multi-Use Chairs	204
Multi-Use Chairs	206

Multi-Use Chairs

Multi-use chairs are suitable for use as occasional seating within team spaces, workstations, offices, or wherever extra seating is required.

- Ally 463 Series
- Player 475 Series
- Move 490 Series
- Snodgrass 474 Series

► For additional multi-use chairs, see page 216.

Move 490 Series

Move chairs are guest chairs that also stack. Live dynamic seat, open cantilever arm design, light weight, and strength make Move a logical choice for multipurpose areas. Move's simple design complements a broad range of work settings.

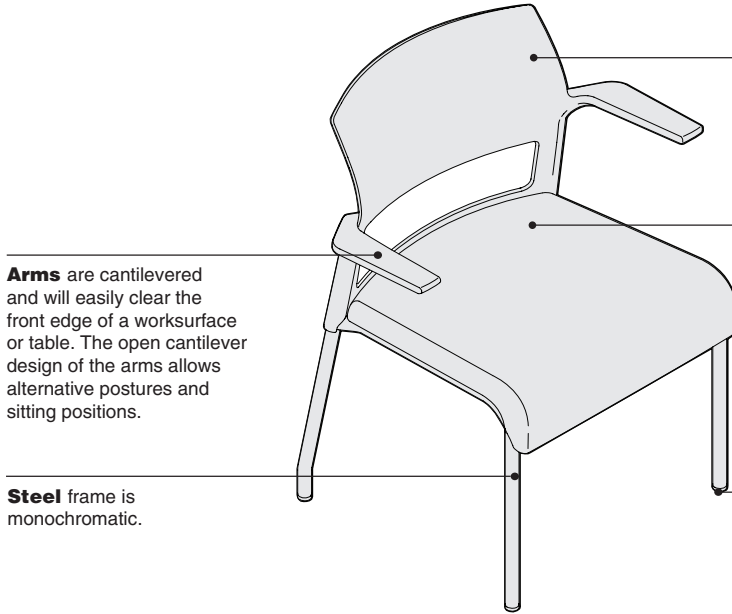

Arms are cantilevered and will easily clear the front edge of a worksurface or table. The open cantilever design of the arms allows alternative postures and sitting positions.

Steel frame is monochromatic.

Back is available in plastic or with an upholstered cushion.

Seat is fully upholstered.

Plastic glides have a stainless steel insert.

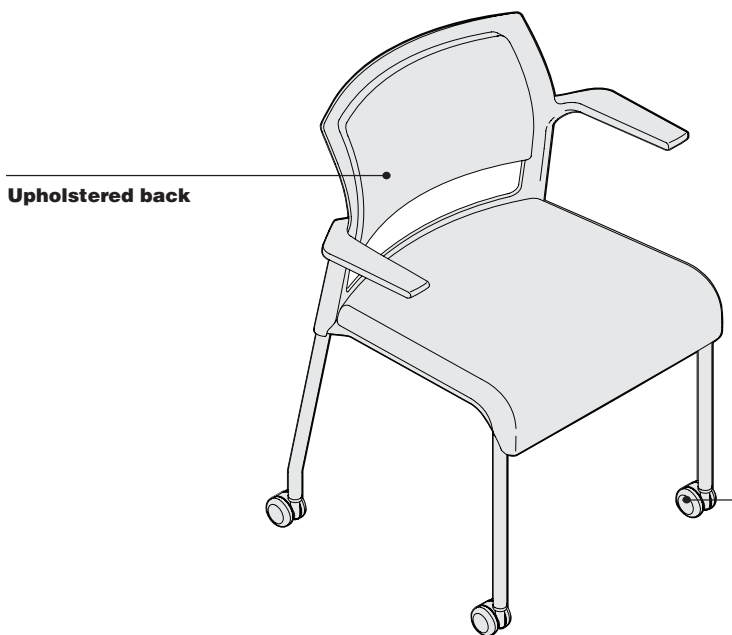

Upholstered back

Casters have hard, dual wheels that roll smoothly on carpets. Soft, dual-wheel casters are available for use on hard floor or chair mats. Casters are available in black only.

Product Details

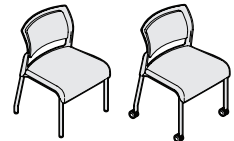
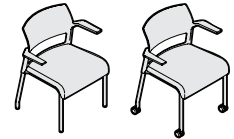

Chairs have a leg-base and are available with glides or casters, and with or without arms.

Stackability for leg base models is five high on the floor.

Plastic glides with stainless steel inserts are recommended for carpeted surfaces.

Soft glides for use on non-carpeted surfaces are available as an option.

Surface Materials

▶ See surface materials on page 248 for specific availability or refer to the *Surface Materials Reference Manual* for further information.

Upholstery

- Fabric
- Fabric with soil retardant treatment (option)
- Leather
- Vinyl

Frame

- 0835 Black paint
- 4799 Platinum paint

Back shell and arms

- Plastic

Casters

- Black only

Glides

- Plastic with stainless steel inserts

All Steelcase seating with standard upholstery fabrics

complies with requirements of the BIFMA First Generation Voluntary Upholstered Furniture Flammability Standard, as well as the State of California Technical Bulletin 117. All standard seating is labeled to be in compliance with California TB117.

Programs & Services

▶ See the *Surface Materials Reference Manual* for further detail about programs and services offered for seating.

The Customer's Own Material (COM) Program

offers the opportunity for customers to select fabrics that are not offered through the standard Steelcase surface materials program for use on Steelcase products. Through the COM program, Steelcase will test your materials for application on Steelcase products. Once approved, you can place your order. Steelcase will facilitate the entire ordering process and give you a production schedule. Steelcase will order the COM fabric directly from the textile manufacturer. For up-to-date information regarding fabric test results for all COM fabrics and details regarding yardage requirements for most Seating lines, visit the COM Web site:

- Visit www.steelcase.com
- Click on "Knowledge & Design"
- Select "Customer's Own Material"

Soil retardants are treatments that provide long-term soil and stain resistance to a fabric without affecting the shade or the integrity of the fabric. The following Steelcase Textiles are available pre-treated with soil retardant. (You do not need to select the soil-retardant option for these fabrics and incur the upcharge.)

- Jacks
- Link
- Regis
- Roulette
- Skittles
- Spyder

Soil-retardant treatment is available on all other seating fabrics at an additional upcharge per seating unit. To order this option, please select "Soil-Retardant Treatment" under "Optional Accessories."

For soil-retardant treatment on COMs, please select "Soil-Retardant Treatment" under "Optional Accessories." Minimums or additional yardage may be required. Please contact the vendor directly for specific information.

Extended lead times may be necessary for this service.

Contact your Steelcase Solutions Fulfillment Team Representative at 1.888.STEELCASE (1.888.783.3522).

Dimensions

▶ Page 202

Resources

Printed Materials

▶ Move Brochure (06-0001424)

Dimensions

Move 490 Series

Overall Depth	Width	Height	Seat Depth	Functional Seat Depth	Seat Width	Seat Height from Floor	Back Width	Back Height from Seat
Move 490 Series								
Chair with Arms								
20¼"	25¾"	31½"	18½"	16⅞"	19"	18½"	19"	15¼"
Chair without Arms								
20¼"	21"	31½"	18½"	16⅞"	19"	18½"	19"	15¼"

• Back • Lumbar • Height	• Width • Between • Arms	• Arm • to • Floor	• Arm • Height • from • Seat	• Seat • Pan • Angle	• Angle • Between • Seat and • Back
--------------------------------	--------------------------------	--------------------------	---------------------------------------	----------------------------	--

Chair with Arms

10"	20½"	25¾"	8¾"	5°	95°
-----	------	------	-----	----	-----

Chair without Arms

10"	N.A.	N.A.	N.A.	5°	95°
-----	------	------	------	----	-----

Move 490 Series Value Package Multi-Use Chairs

Buzz2 Fabric on Seat with Black on Frame and Back Shell

164 PRICE ADJUSTMENT: Products reflect 164 pricing, a 3% price increase is not required. The Canadian pricing factor is 1.2 for Price List 138.



Tip: Value package chairs allow you to obtain pre-selected features at a lower price than if specifying as a standard model number.

Tip: Options or substitutions are not available on this value package



Standard Includes	Required to Specify
-------------------	---------------------

- | | | |
|--|---|---|
| <ul style="list-style-type: none"> ▶ Need help? Product details, page 200 | <ul style="list-style-type: none"> • Frame: 0835 Black paint • Back shell: 6205 Black plastic • Seat: Buzz2 fabric • Arms, if selected: 6205 Black plastic • Glides, if selected: plastic with stainless steel inserts • Hard, dual-wheel casters, if selected: black | <ul style="list-style-type: none"> 1 Style number 2 Buzz2 fabric color number for seat ▶ See <i>Surface Materials</i>, page 248. |
|--|---|---|

Specification Information

Style Number	U.S. Price
--------------	------------

Without Arms

With Glides

490410V	\$215
----------------	-------

With Casters

490410VC	\$256
-----------------	-------

With Arms

With Glides

490412V	\$265
----------------	-------

With Casters

490412VC	\$306
-----------------	-------

Move 490 Series Multi-Use Chairs

164 **PRICE ADJUSTMENT: Products reflect 164 pricing, a 3% price increase is not required. The Canadian pricing factor is 1.2 for Price List 138.**



Standard Includes	Required to Specify
<ul style="list-style-type: none"> ▶ Need help? Product details, page 200 • Frame: 0835 Black paint • Back shell: plastic • Seat: fabric price group 1 • Arms, if selected: plastic to match back shell • Glides, if selected: plastic with stainless steel inserts • Hard, dual-wheel casters, if selected: black 	<ul style="list-style-type: none"> 1 Style number 2 Plastic color number for back shell 3 Fabric color number for seat 4 Options, if selected (see below) ▶ See <i>Surface Materials</i>, page 248.

Options	U.S. Price	Required to Specify
Surface Materials Upholstery on seat <ul style="list-style-type: none"> • Fabric price group 1 No cost • Fabric price group 2 +\$ 10 • Fabric price group 3 +\$ 21 • Fabric price group 4 +\$ 29 • Fabric price group 5 +\$ 36 • Fabric price group 6 +\$ 44 • Fabric price group 7 +\$ 52 • Fabric price group 8 +\$ 65 • Fabric price group 9 +\$ 80 • Fabric price group 10 +\$ 91 • Customer's Own Material (COM) No cost • Steelcase leather upholstery +\$ 75 • Soil-retardant treatment applied to upholstery fabric +\$ 21 		<ul style="list-style-type: none"> Specify fabric color number. Specify fabric color number. Specify fabric color number. Specify fabric color number. Specify fabric color number. Specify fabric color number. Specify fabric color number. Specify fabric color number. Specify fabric color number. Specify fabric color number. ▶ See <i>Surface Materials Reference Manual</i> to specify. Specify leather color number. Specify <i>with soil-retardant treatment</i>.
Upholstery on seat and back <ul style="list-style-type: none"> • Fabric price group 1 No cost • Fabric price group 2 +\$ 21 • Fabric price group 3 +\$ 41 • Fabric price group 4 +\$ 57 • Fabric price group 5 +\$ 72 • Fabric price group 6 +\$103 • Fabric price group 7 +\$144 • Fabric price group 8 +\$191 • Fabric price group 9 +\$227 • Fabric price group 10 +\$263 • Customer's Own Material (COM) No cost • Steelcase leather upholstery +\$150 • Soil-retardant treatment applied to upholstery fabric +\$ 21 		<ul style="list-style-type: none"> Specify fabric color number. Specify fabric color number. Specify fabric color number. Specify fabric color number. Specify fabric color number. Specify fabric color number. Specify fabric color number. Specify fabric color number. Specify fabric color number. Specify fabric color number. ▶ See <i>Surface Materials Reference Manual</i> to specify. Specify leather color number. Specify <i>with soil-retardant treatment</i>.
Frame <ul style="list-style-type: none"> • Platinum frame +\$ 50 		<ul style="list-style-type: none"> Specify <i>with 4799 Platinum frame</i>.
Glides <ul style="list-style-type: none"> • Soft glides for use on non-carpeted floors +\$ 6 		<ul style="list-style-type: none"> Specify <i>with soft glides</i>.
Castors <ul style="list-style-type: none"> • Soft, dual-wheel casters for use on hard floors +\$ 19 		<ul style="list-style-type: none"> Specify <i>with soft casters</i>.

▶ Detailed dimensions, page 202

164 PRICE ADJUSTMENT: Products reflect 164 pricing, a 3% price increase is not required. The Canadian pricing factor is 1.2 for Price List 138.

Specification Information

Style Number	U.S. Base Price
--------------	-----------------

Plastic Back Without Arms

With Glides

490410	\$240
--------	-------

With Casters

490410C	\$281
---------	-------

Upholstered Back Without Arms

With Glides

490410U	\$290
---------	-------

With Casters

490410UC	\$331
----------	-------

Plastic Back with Arms

With Glides

490412	\$290
--------	-------

With Casters

490412C	\$331
---------	-------

Upholstered Back with Arms

With Glides

490412U	\$340
---------	-------

With Casters

490412UC	\$381
----------	-------



Move 490 Series



Understanding and Specifying Snodgrass 474 Series Multi-Use Chairs

Understanding Snodgrass 474 Series

Details	210
Dimensions	212

Specifying Snodgrass 474 Series

Multi-Use Chairs	214
------------------	-----

Multi-Use Chairs

Multi-use chairs are suitable for use as occasional seating within team spaces, workstations, offices, or wherever extra seating is required.

- Ally 463 Series
- Player 475 Series
- Move 490 Series
- Snodgrass 474 Series

► For additional multi-use chairs, see page 216.

Snodgrass 474 Series

Snodgrass, designed by Warren Snodgrass, offers guest and occasional seating of classic simplicity. With a choice of metal or wood frames, Snodgrass has enduring design that is always in style.

Frame is available in monochromatic colors or wood veneer.

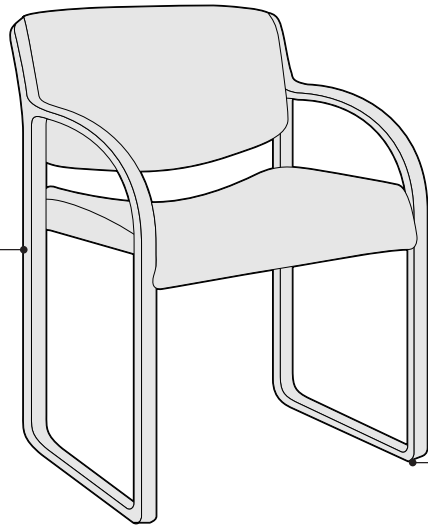

Glides are clear plastic.

Product Details

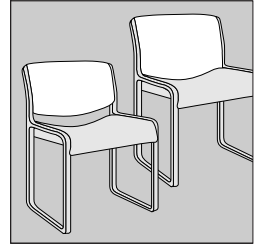

Two back shapes are available, open back or full back.

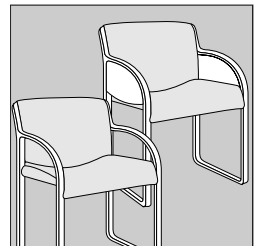

Two arm styles—open and enclosed—are available. Open arm is available on monochromatic and wood models. Enclosed arm is available on wood models. Armless models are also available on monochromatic models.

Surface Materials

▶ See surface materials on page 248 for specific availability or refer to the *Surface Materials Reference Manual* for further information.

Upholstery

- Fabric
- Fabric with soil retardant treatment (option)
- Vinyl
- Leather

Frame

- Monochromatic color from list of seating plastic color numbers can be applied to the frame.
 - Wood
- Tip: Frames are constructed of solid maple. Finishes applied to maple will match the color of stains applied to oak, walnut, or cherry, but will not show the same natural grain.*

Glides

- Clear plastic

All Steelcase seating with standard upholstery fabrics complies with requirements of the BIFMA First Generation Voluntary Upholstered Furniture Flammability Standard, as well as the State of California Technical Bulletin 117. All standard seating is labeled to be in compliance with California TB117.

Programs & Services

▶ See the *Surface Materials Reference Manual* for further detail about programs and services offered for seating.

The Customer's Own Material (COM) Program

offers the opportunity for customers to select fabrics that are not offered through the standard Steelcase surface materials program for use on Steelcase products. Through the COM program, Steelcase will test your materials for application on Steelcase products. Once approved, you can place your order. Steelcase will facilitate the entire ordering process and give you a production schedule. Steelcase will order the COM fabric directly from the textile manufacturer. For up-to-date information regarding fabric test results for all COM fabrics and details regarding yardage requirements for most Seating lines, visit the COM Web site. To locate the COM Web site:

- Visit www.steelcase.com
- Click on "Knowledge & Design"
- Select "Customer's Own Material"

Soil retardants are treatments that provide long-term soil and stain resistance to a fabric without affecting the shade or the integrity of the fabric. The following Steelcase Textiles are available pre-treated with soil retardant. (You do not need to select the soil-retardant option for these fabrics and incur the upcharge.)

- Jacks
- Link
- Regis
- Roulette
- Skittles
- Spyder

Soil-retardant treatment is available on all other seating fabrics at an additional upcharge per seating unit. To order this option, please select "Soil-Retardant Treatment" under "Optional Accessories."

For soil-retardant treatment on COMs, please select "Soil-Retardant Treatment" under "Optional Accessories." Minimums or additional yardage may be required. Please contact the vendor directly for specific information.

Extended lead times may be necessary for this service.

Contact your Steelcase Solutions Fulfillment Team Representative at 1.888.STEELCASE (1.888.783.3522).

Fire Codes

▶ See pages 254–255 for upholstery fabrics available for use with FCS modification.

Steelcase offers Fire Code Seating modification (FCS) on nearly all seating models. The most rigorous fire codes in the nation have been developed in California, and the Steelcase FCS modification is designed to meet those codes. Fire Code Seating (FCS) indicates that a product is constructed to meet the strict fire code requirements of high public occupancy areas such as theaters, meeting rooms, and lobbies. The FCS standards will meet both the State of California Home Furnishing Technical Bulletin 133 (Cal TB 133) and Boston Fire Code (BFC). Boston adopted the California Home Furnishing Technical Bulletin TB 133 test standard in 1992.

Local codes may have special requirements for upholstery.

Dimensions

▶ Page 212

Resources

Printed Materials
▶ Snodgrass Brochure (S11006)

Dimensions

Snodgrass 474 Series

• Features	• Overall Depth	Width	Height	• Seat Depth	• Functional Seat Depth	• Seat Width	• Seat Height from Floor	• Back Width	• Back Height from Seat
------------	-----------------	-------	--------	--------------	-------------------------	--------------	--------------------------	--------------	-------------------------

Snodgrass 474 Series

Chair with Open Loop Arms

23½"	22¾"	31½"	21"	17½"	20"	18¼"	20"	14¼"
------	------	------	-----	------	-----	------	-----	------

Chair with Enclosed Arms

23½"	22¾"	31½"	21"	17½"	20"	18¼"	20"	14¼"
------	------	------	-----	------	-----	------	-----	------

Chair without Arms

23½"	22¾"	31½"	21"	17½"	20"	18¼"	20"	14¼"
------	------	------	-----	------	-----	------	-----	------

• Back • Lumbar • Height	• Width • Between • Arms	• Arm • to • Floor	• Arm • Height • from • Seat	• Seat • Pan • Angle	• Angle • Between • Seat and • Back
--------------------------------	--------------------------------	--------------------------	---------------------------------------	----------------------------	--

Chair with Open Loop Arms

7"	20"	25¼"	7"	5°	103°
----	-----	------	----	----	------

Chair with Enclosed Arms

7"	20"	25¼"	7"	5°	103°
----	-----	------	----	----	------

Chair without Arms

7"	20"	25¼"	7"	5°	103°
----	-----	------	----	----	------

Snodgrass 474 Series Multi-Use Chairs

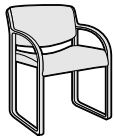

Standard Includes	Required to Specify
<ul style="list-style-type: none"> ▶ Need help? Product details, page 210 • Frame and arms, if selected: monochromatic color, or wood veneer • Upholstery: fabric price group 1 • Glides: clear plastic 	<ol style="list-style-type: none"> 1 Style number 2 Monochromatic color number from seating plastic colors for frame 3 Fabric color number for upholstery 4 Options, if selected (see below) <p>▶ See <i>Surface Materials</i>, page 248.</p>

Options		U.S. Price	Required to Specify
Surface Materials	Upholstery		
	<ul style="list-style-type: none"> • Fabric price group 1 • Fabric price group 2 • Fabric price group 3 • Fabric price group 4 • Fabric price group 5 • Fabric price group 6 • Fabric price group 7 • Fabric price group 8 • Fabric price group 9 • Fabric price group 10 • Leather price group • Customer's Own Material/Leather (COM/COL) • Fire Code Seating (FCS) • Soil-retardant treatment applied to upholstery fabric • Customiz stain on wood 	<p>No cost</p> <p>+\$ 20</p> <p>+\$ 40</p> <p>+\$ 55</p> <p>+\$ 70</p> <p>+\$ 85</p> <p>+\$100</p> <p>+\$125</p> <p>+\$155</p> <p>+\$175</p> <p>+\$450</p> <p>+\$ 30</p> <p>+\$ 55</p> <p>+\$ 20</p> <p>+\$ 24</p>	<p>Specify fabric color number.</p> <p>Specify fabric color number.</p> <p>Specify fabric color number.</p> <p>Specify fabric color number.</p> <p>Specify fabric color number.</p> <p>Specify fabric color number.</p> <p>Specify fabric color number.</p> <p>Specify fabric color number.</p> <p>Specify fabric color number.</p> <p>Specify fabric color number.</p> <p>Specify leather color number.</p> <p>▶ See <i>Surface Materials Reference Manual</i> to specify.</p> <p>Add suffix F to the style number. Specify <i>with soil-retardant treatment</i>.</p> <p>▶ See <i>Surface Materials Reference Manual</i>.</p>

Tip: Fire Code Seating (FCS) option is available with certain upholstery fabric choices only.

▶ Pages 254–255

▶ Detailed dimensions, page 212



For **164** U.S., multiply all **162** U.S. prices by 1.03. Multiply **164** U.S. by 1.2 for **138** Canadian price.

▶ See page 1 for details.

Specification Information

Open Loop Arms with Open Back



• **Style
Number**
:
:
:

• **U.S.
Base
Price**
:
:
:

Open Loop Arms With Full Back



• **Style
Number**
:
:
:

• **U.S.
Base
Price**
:
:
:

Enclosed Arms with Full Back



• **Style
Number**
:
:
:

• **U.S.
Base
Price**
:
:
:

Monochromatic

474419M \$603

474429M \$619

N.A.

Wood

474419W \$891

474429W \$907

474427W \$1107

Armless with Open Back



• **Style
Number**
:
:
:

• **U.S.
Base
Price**
:
:
:

Armless with Full Back



• **Style
Number**
:
:
:

• **U.S.
Base
Price**
:
:
:

Monochromatic

474410M \$570

474420M \$586

US 

For **164** U.S., multiply all
162 U.S. prices by 1.03.
Multiply **164** U.S. by 1.2 for
138 Canadian price.
▶ See page 1 for details.

Additional Multi-Use Chairs

Jersey Multi-Use Chairs

With Arms



Without Arms



With Arms and Casters



Without Arms and With Casters



▶ See pages 115–118

Sensor 458 Series Size II Mid-Back Multi-Use Chairs

Sled-Base



▶ See page 136

Rally 457 Series Mid-Back Multi-Use Chairs

Arms With Plastic Arm Caps



Without Arms



Sled-Base With Arms and Plastic Arm Caps



▶ See page 144

Protegé 433 Series Multi-Use Chairs

Arms



Arms With Soft Arm Caps



Without Arms



Arms



Arms With Soft Arm Caps



▶ See pages 156–158

Cachet 487 Series Multi-Use Chairs

With Flip-Up Arms



Without Arms



▶ See page 166

Understanding and Specifying Parade! 470 Series Stackable Chairs

Understanding Parade! 470 Series

Details	218
Dimensions	220

Specifying Parade! 470 Series

Stackable Chairs	222
Accessories	223

Stackable Chairs

Stackable chairs offer flexibility and ease of use in classrooms, auditoriums, or wherever extra seating is required.

- Parade! 470 Series
- Max-Stacker 472 Series
- Max-Stacker II 473 Series
- Cachet 487 Series
- Player 475 Series
Leg-Base Chairs
- Ally 463 Series

Parade! 470 Series

Parade! offers a stylish choice in stackers with a plastic contoured seat and back that encourages proper posture. Constructed with a half-inch carbon steel rod and a unique plastic seat and back for strength and durability, the arch and cantilever frame makes Parade! a good selection for dining areas and offices as well as classrooms and auditoriums.

Seat and back are plastic to provide strength and durability.

Arms are available with or without colored plastic arm caps.

Clear plastic glides are standard. Soft glides, optional, are recommended for use on non-carpeted floors.

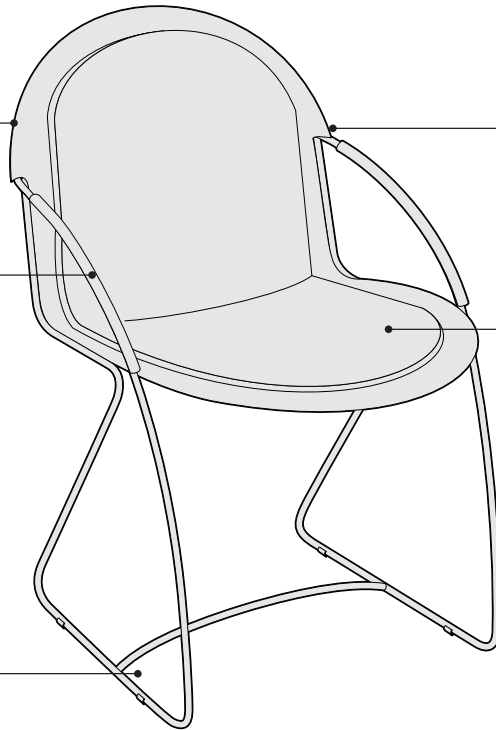

Wire rod frame is 1/2"-diameter carbon steel.

Upholstered foam cushion is available for the seat and back.

Product Details

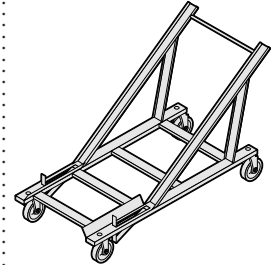

Transport and storage dolly is available to stack, move, and store up to 24 non-upholstered or 16 upholstered chairs. Because stacking bumpers are used on upholstered models, stacking capacity is 16 chairs per dolly.

Fully loaded transport dolly measures 54 1/2"D x 21 3/8"W x 68 1/2"H.

Without transport dolly stack can be up to six chairs high.

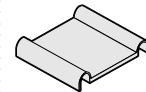

Alignment device is available to temporarily link chairs together in the field for evenly spaced rows. Chairs can be unlinked easily. Spacing between chairs linked with alignment device is 2 1/4".

Surface Materials

▶ See surface materials on page 248 for specific availability or refer to the *Surface Materials Reference Manual* for further information.

Hard components (frame and arms)

- Seating coating
- 9201 Polished Chrome

Seat and back

- Plastic color

Upholstered cushion

- Fabric
- Fabric with soil retardant treatment (option)

Arm caps

- Plastic color

Glides

- Clear plastic
- Soft

All Steelcase seating with standard upholstery fabrics complies with requirements of the BIFMA First Generation Voluntary Upholstered Furniture Flammability Standard, as well as the State of California Technical Bulletin 117. All standard seating is labeled to be in compliance with California TB117.

Programs & Services

▶ See the *Surface Materials Reference Manual* for further detail about programs and services offered for seating.

The Customer's Own Material (COM) Program

offers the opportunity for customers to select fabrics that are not offered through the standard Steelcase surface materials program for use on Steelcase products. Through the COM program, Steelcase will test your materials for application on Steelcase products. Once approved, you can place your order. Steelcase will facilitate the entire ordering process and give you a production schedule. Steelcase will order the COM fabric directly from the textile manufacturer. For up-to-date information regarding fabric test results for all COM fabrics and details regarding yardage requirements for most Seating lines, visit the COM Web site. To locate the COM Web site:

- Visit www.steelcase.com
- Click on "Knowledge & Design"
- Select "Customer's Own Material"

Soil retardants are treatments that provide long-term soil and stain resistance to a fabric without affecting the shade or the integrity of the fabric. The following Steelcase Textiles are available pre-treated with soil retardant. (You do not need to select the soil-retardant option for these fabrics and incur the upcharge.)

- Jacks
- Link
- Regis
- Roulette
- Skittles
- Spyder

Soil-retardant treatment is available on all other seating fabrics at an additional upcharge per seating unit. To order this option, please select "Soil-Retardant Treatment" under "Optional Accessories."

For soil-retardant treatment on COMs, please select "Soil-Retardant Treatment" under "Optional Accessories." Minimums or additional yardage may be required. Please contact the vendor directly for specific information.

Extended lead times may be necessary for this service.

Contact your Steelcase Solutions Fulfillment Team Representative at 1.888.STEELCASE (1.888.783.3522).

Steelcase Fire Code Seating (FCS) is not available on Parade! seating

Local codes may have special requirements for upholstery.

Dimensions

▶ Page 220

Resources

Printed Materials

▶ Stackable Seating Brochure (02-0002354)

Dimensions

Parade! 470 Series

• Features	• Overall • Depth	Width	Height	• Seat • Depth	• Functional • Seat • Depth	• Seat • Width	• Seat • Height • from • Floor	• Back • Width	• Back • Height • from • Seat
------------	----------------------	-------	--------	-------------------	-----------------------------------	-------------------	---	-------------------	--

Parade! 470 Series

Chair without Arm Caps

23"	20½"	32"	17"	17"	19"	17½"	19"	16½"
-----	------	-----	-----	-----	-----	------	-----	------

Chair with Arm Caps

23"	21"	32"	17"	17"	19"	17½"	19"	16½"
-----	-----	-----	-----	-----	-----	------	-----	------

• Back Lumbar Height	• Width Between Arms	• Arm to Floor	• Arm Height from Seat	• Seat Pan Angle	• Angle Between Seat and Back
----------------------	----------------------	----------------	------------------------	------------------	-------------------------------

Chair without Arm Caps

10"	19¼"	24¾"	7¼"	7°	101°
-----	------	------	-----	----	------

Chair with Arm Caps

10"	19"	25"	7½"	7°	101°
-----	-----	-----	-----	----	------

Parade! 470 Series Stackable Chairs



Standard Includes	Required to Specify
<ul style="list-style-type: none"> ▶ Need help? Product details, page 218 • Frame and arms: seating coating or 9201 Polished Chrome • Seat and back: plastic color • Arm caps, if selected: plastic color • Cushions, if selected: upholstery • Glides: clear plastic 	<ol style="list-style-type: none"> 1 Style number 2 Seating coating color number for frame 3 Plastic color number for seat, back, and arm caps 4 Fabric color number for cushion 5 Options, if selected (see below) <p>▶ See <i>Surface Materials</i>, page 248.</p>

Options	U.S. Price	Required to Specify
Surface Materials Upholstered cushion <ul style="list-style-type: none"> • Fabric price group 1 • Fabric price group 2 • Fabric price group 3 • Fabric price group 4 • Fabric price group 5 • Fabric price group 6 • Fabric price group 7 • Fabric price group 8 • Fabric price group 9 • Fabric price group 10 • Customer's Own Material (COM) • Soil-retardant treatment applied to upholstery fabric 	<ul style="list-style-type: none"> +\$111 +\$131 +\$151 +\$166 +\$181 +\$196 +\$211 +\$236 +\$266 +\$286 +\$141 +\$ 20 	<p>Add suffix U to the style number and specify fabric color number.</p> <p>Add suffix U to the style number and specify fabric color number.</p> <p>Add suffix U to the style number and specify fabric color number.</p> <p>Add suffix U to the style number and specify fabric color number.</p> <p>Add suffix U to the style number and specify fabric color number.</p> <p>Add suffix U to the style number and specify fabric color number.</p> <p>Add suffix U to the style number and specify fabric color number.</p> <p>Add suffix U to the style number and specify fabric color number.</p> <p>Add suffix U to the style number and specify fabric color number.</p> <p>Add suffix U to the style number and specify fabric color number.</p> <p>▶ See <i>Surface Materials Reference Manual</i> to specify.</p> <p>Specify <i>with soil-retardant treatment</i>.</p>
Glides <ul style="list-style-type: none"> • Soft glides for use on non-carpeted floors 	<ul style="list-style-type: none"> +\$ 6 	<p>Specify <i>with soft glides</i>.</p>

Specification Information		
Frame Finish	Style Number	U.S. Base Price

Without Arm Caps		
Coated frame	470419N	\$184
Polished Chrome frame	470419	\$184

With Plastic Arm Caps		
Coated frame	470412N	\$197
Polished Chrome frame	470412	\$197



▶ Detailed dimensions, page 220

Alignment Device

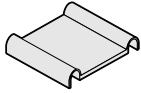

Standard Includes	Required to Specify
• Carton of 12 alignment devices: black plastic only	Style number

Specification Information

Style Number	U.S. Price
470G	\$27

Transport and Storage Dolly

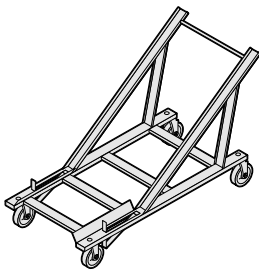

Standard Includes	Required to Specify
• Transport and storage dolly: black paint only	Style number

Specification Information

Style Number	U.S. Price
470D	\$436

US

For **164** U.S., multiply all **162** U.S. prices by 1.03.
 Multiply **164** U.S. by 1.2 for **138** Canadian price.
 ▶ See page 1 for details.



Understanding and Specifying Max-Stacker 472 Series Stackable Chairs

Understanding Max-Stacker 472 Series

Details	226
Dimensions	228

Specifying Max-Stacker 472 Series

Stackable Chairs	230
Accessories	232

Stackable Chairs

Stackable chairs offer flexibility and ease of use in classrooms, auditoriums, or wherever extra seating is required.

- Parade! 470 Series
- Max-Stacker 472 Series
- Max-Stacker II 473 Series
- Player 475 Series Leg-Base Chairs
- Ally 463 Series

Max-Stacker 472 Series

Max-Stacker provides stackable seating for high-traffic applications. Its clean lines and durable steel rod frame have made the Max-Stacker a universally popular stacker selection.

Tablet arms and bookracks are available factory or field installed.

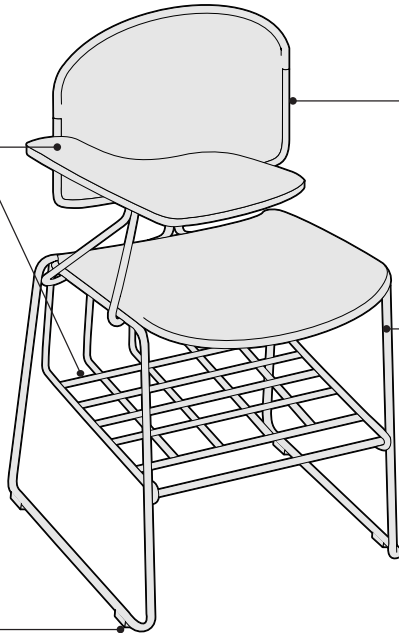

Plastic glides are standard. Soft glides, optional, are recommended for use on non-carpeted floors.

Back and seat are available in flexible, contoured plastic.

Two-piece wire-rod frame is $\frac{7}{16}$ " diameter carbon steel for strength and durability.

Product Details

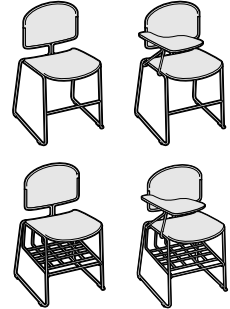

Four models are available—chairs without arms, chairs with bookracks, chairs with tablet arms, and chairs with a combination of bookrack and tablet arm.

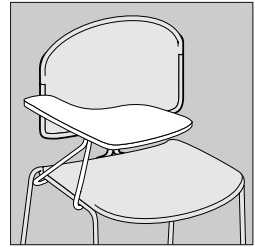

Tablet arms provide a writing surface that is $12\frac{1}{2}$ "D x $11\frac{3}{8}$ "W. They are available in left- or right-hand models.

Clearance between tablet arm and seat is $7\frac{1}{4}$ "H. Tablet arm tilts for easy entrance and exit from chair.

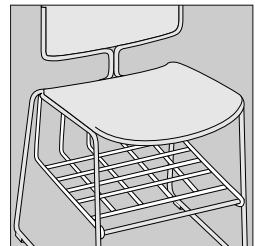

Bookrack is available factory or field installed for convenient storage of notebooks and purses.

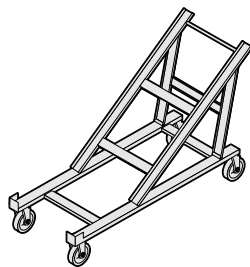

Transport and storage dolly is available to stack, move, and store up to 45 chairs. Chairs with bookracks and tablet arms cannot be stacked.

Unloaded transport dolly measures 55"D x 22"W x 37½"H.

Fully loaded transport dolly measures 57"D x 22"W x 68½"H.

Without transport dolly stack can be up to 12 chairs high.

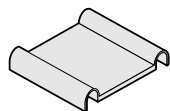

Alignment device is available to temporarily link chairs without tablet arms together in the field for evenly spaced rows. Chairs can be unlinked easily. Spacing between chairs linked with alignment device is 2¼".

Surface Materials

▶ See surface materials on page 248 for specific availability or refer to the *Surface Materials Reference Manual* for further information.

Hard components (frame)

- Seating coating
- 9201 Polished Chrome

Back and seat

- Plastic color

Bookrack

- Coated to match the frame color on seating coated models
- 9201 Polished Chrome on Polished Chrome models

Tablet arms

- Laminate

Glides

- Clear plastic
- Soft

Programs & Services

▶ See the *Surface Materials Reference Manual* for further detail about programs and services offered for seating.

Dimensions

▶ Page 228

Resources

Printed Materials

▶ Stackable Seating Brochure (02-0002354)

Dimensions

Max-Stacker 472 Series

• Overall • Depth	Width	Height	• Seat • Depth	• Functional • Seat • Depth	• Seat • Width	• Seat • Height • from • Floor	• Back • Width	• Back • Height • from • Seat	• Back • Lumbar • Height
Max-Stacker 472 Series									
21½"	20"	30¼"	17¾"	16¾"	18¼"	17½"	18¼"	14¾"	9½"

• Width • Between • Arms	• Arm • to • Floor	• Arm • Height • from • Seat	• Seat • Pan • Angle	• Angle • Between • Seat and • Back
--------------------------------	--------------------------	---------------------------------------	----------------------------	--

N.A.	N.A.	N.A.	8°	93°
------	------	------	----	-----

Max-Stacker 472 Series Stackable Chairs

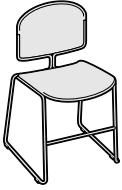

Standard Includes		Required to Specify	
<ul style="list-style-type: none"> ▶ Need help? Product details, page 226 	<ul style="list-style-type: none"> • Frame: seating coating or 9201 Polished Chrome • Seat and back: plastic • Tablet arm, if selected: laminate • Bookrack, if selected: high-wear coating or 9201 Polished Chrome • Glides: plastic 		<ol style="list-style-type: none"> 1 Style number 2 Seating coating color number for frame and bookrack 3 Plastic color number for back and seat 4 Laminate color number for tablet arm 5 Options, if selected (see below) <ul style="list-style-type: none"> ▶ See <i>Surface Materials</i>, page 248.
Options		U.S. Price	Required to Specify
Glides	<ul style="list-style-type: none"> • Soft glides for use on non-carpeted floors 	+\$6	Specify <i>with soft glides</i> .

▶ Detailed dimensions, page 228



For **164** U.S., multiply all **162** U.S. prices by 1.03.
 Multiply **164** U.S. by 1.2 for **138** Canadian price.
 ▶ See page 1 for details.

Specification Information

Frame Finish	Style Number	U.S. Base Price
--------------	--------------	-----------------

Without Arms

Coated frame	472410N	\$138
Polished Chrome frame	472410	\$138

With Tablet Arm

Right-Hand

Coated frame	472410NTR	\$257
Polished Chrome frame	472410TR	\$257

Left-Hand

Coated frame	472410NTL	\$257
Polished Chrome frame	472410TL	\$257

With Bookrack

Coated frame	472410NBR	\$210
Polished Chrome frame	472410BR	\$210

With Right-Hand Tablet Arm

Coated frame	472410NTRB	\$329
Polished Chrome frame	472410TRB	\$329

With Left-Hand Tablet Arm

Coated frame	472410NTLB	\$329
Polished Chrome frame	472410TLB	\$329



US 
 For **164** U.S., multiply all **162** U.S. prices by 1.03.
 Multiply **164** U.S. by 1.2 for **138** Canadian price.
 ▶ See page 1 for details.

Max-Stacker 472 Series Accessories

Tablet Arm Assembly

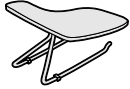

Standard Includes	Required to Specify
<ul style="list-style-type: none"> • Tablet arm frame: seating coating or 9201 Polished Chrome • Tablet arm worksurface: laminate 	<ul style="list-style-type: none"> 1 Style number 2 Laminate color number 3 Color number for tablet arm frame ▶ See <i>Surface Materials</i>, page 248.

Specification Information

• Style Number	• U.S. Price
Right-hand	
472TAR	\$119
Left-hand	
472TAL	\$119
•	•

Bookrack Assembly



Standard Includes	Required to Specify
<ul style="list-style-type: none"> • Bookrack assembly: seating coating or 9201 Polished Chrome 	<ul style="list-style-type: none"> 1 Style number 2 Color number for bookrack ▶ See <i>Surface Materials</i>, page 248.

Specification Information

• Style Number	• U.S. Price
472BR	\$72
•	•

Alignment Device

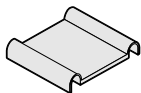

Standard Includes	Required to Specify
<ul style="list-style-type: none"> • Carton of 12 alignment devices: black plastic only 	<ul style="list-style-type: none"> Style number

Specification Information

• Style Number	• U.S. Price
472G	\$26
•	•

US
 For **164** U.S., multiply all **162** U.S. prices by 1.03.
 Multiply **164** U.S. by 1.2 for **138** Canadian price.
 ▶ See page 1 for details.

Transport and Storage Dolly

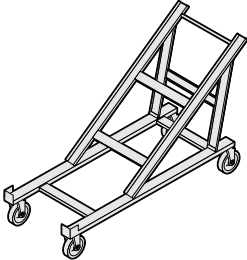

Standard Includes	Required to Specify
• Transport and storage dolly: black paint only	Style number

Specification Information

Style Number	U.S. Price
473D	\$396

Max-Stacker 472 Series

US 
For **164** U.S., multiply all **162** U.S. prices by 1.03.
Multiply **164** U.S. by 1.2 for **138** Canadian price.
▶ See page 1 for details.



Understanding and Specifying Max-Stacker II 473 Series Stackable Chairs

Understanding Max-Stacker II 473 Series

Details	236
Dimensions	238

Specifying Max-Stacker II 473 Series

Stackable Chairs	240
Accessories	242

Stackable Chairs

Stackable chairs offer flexibility and ease of use in classrooms, auditoriums, or wherever extra seating is required.

- Parade! 470 Series
- Max-Stacker 472 Series
- Max-Stacker II 473 Series
- Player 475 Series Leg-Base Chairs
- Ally 463 Series

Max-Stacker II 473 Series

Max-Stacker II offers different visuals with rounded back and curved lines in another great stacking chair.

Tablet arms and bookracks are available factory or field installed.

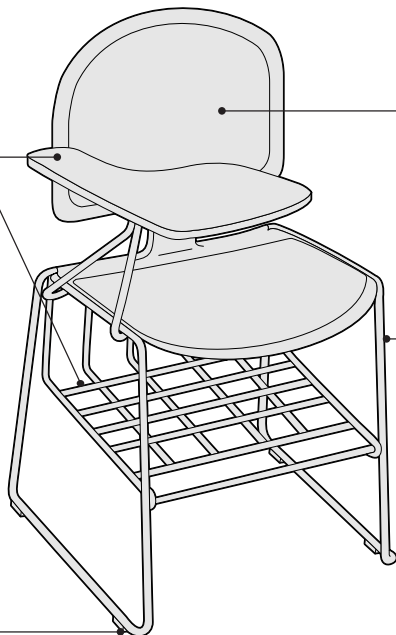

Plastic glides are standard. Soft glides, optional, are recommended for use on non-carpeted floors.

Flexible, contoured back and seat are available in plastic or with upholstered cushions.

Two-piece wire-rod frame is $\frac{7}{16}$ "-diameter carbon steel for strength and durability.

Product Details

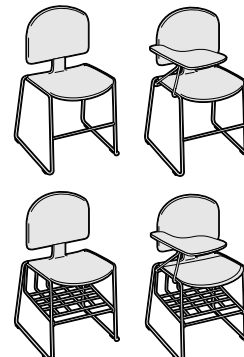

Four models are available—chairs without arms, chairs with bookracks, chairs with tablet arms, and chairs with a combination of bookrack and tablet arm.

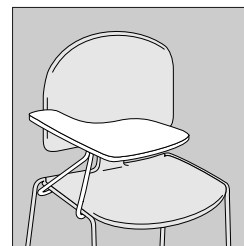

Tablet arms provide a writing surface that is $12\frac{1}{2}$ "D x $11\frac{3}{8}$ "W. They are available in left- or right-hand models.

Clearance between tablet arm and seat is $7\frac{1}{4}$ "H. Tablet arm tilts for easy entrance and exit from chair.

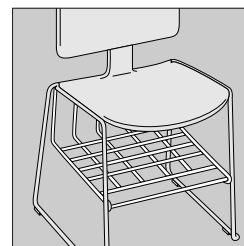

Bookrack is available factory or field installed for convenient storage of notebooks and purses.

Stacking bumpers are provided on upholstered models to protect the fabric when chairs are stacked.

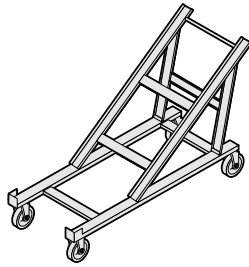

Transport and storage dolly is available to stack, move, and store up to 35 non-upholstered or 25 upholstered chairs. Chairs with bookracks and tablet arms cannot be stacked.

Unloaded transport dolly measures 55"D x 22"W x 37½"H.

Fully loaded transport dolly measures 57"D x 22"W x 68½"H.

Without transport dolly stack can be up to 12 chairs high.

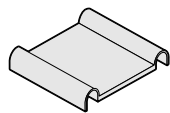

Alignment device is available to temporarily link chairs together in the field for evenly spaced rows. Chairs can be unlinked easily. Spacing between chairs linked with alignment device is 2¼".

Surface Materials

▶ See surface materials on page 248 for specific availability or refer to the *Surface Materials Reference Manual* for further information.

Hard components (frame)

- Seating coating
- 9201 Polished Chrome

Back and seat

- Plastic color
- Upholstery

Upholstery

- Fabric
- Fabric with soil retardant treatment (option)

Bookrack

- Coated to match the frame color on seating coated models
- 9201 Polished Chrome on Polished Chrome models

Tablet arms

- Laminate

Glides

- Clear plastic
- Soft

All Steelcase seating with standard upholstery fabrics complies with requirements of the BIFMA First Generation Voluntary Upholstered Furniture Flammability Standard, as well as the State of California Technical Bulletin 117. All standard seating is labeled to be in compliance with California TB117.

Programs & Services

▶ See the *Surface Materials Reference Manual* for further detail about programs and services offered for seating.

The Customer's Own Material (COM) Program

offers the opportunity for customers to select fabrics that are not offered through the standard Steelcase surface materials program for use on Steelcase products. Through the COM program, Steelcase will test your materials for application on Steelcase products. Once approved, you can place your order. Steelcase will facilitate the entire ordering process and give you a production schedule. Steelcase will order the COM fabric directly from the textile manufacturer. For up-to-date information regarding fabric test results for all COM fabrics and details regarding yardage requirements for most Seating lines, visit the COM Web site. To locate the COM Web site:

- Visit www.steelcase.com
- Click on "Knowledge & Design"
- Select "Customer's Own Material"

Soil retardants are treatments that provide long-term soil and stain resistance to a fabric without affecting the shade or the integrity of the fabric. The following Steelcase Textiles are available pre-treated with soil retardant. (You do not need to select the soil-retardant option for these fabrics and incur the upcharge.)

- Jacks
- Link
- Regis
- Roulette
- Skittles
- Spyder

Soil-retardant treatment is available on all other seating fabrics at an additional upcharge per seating unit. To order this option, please select "Soil-Retardant Treatment" under "Optional Accessories."

For soil-retardant treatment on COMs, please select "Soil-Retardant Treatment" under "Optional Accessories." Minimums or additional yardage may be required. Please contact the vendor directly for specific information.

Extended lead times may be necessary for this service.

Contact your Steelcase Solutions Fulfillment Team Representative at 1.888.STEELCASE (1.888.783.3522).

Steelcase Fire Code Seating (FCS) is not available on Max-Stacker II seating.

Local codes may have special requirements for upholstery.

Dimensions

▶ Page 238

Resources

Printed Materials

▶ Stackable Seating Brochure (02-0002354)

Dimensions

Max-Stacker II 473 Series

• Overall • Depth	Width	Height	• Seat • Depth	• Functional • Seat • Depth	• Seat • Width	• Seat • Height • from • Floor	• Back • Width	• Back • Height • from • Seat	• Back • Lumbar • Height
Max-Stacker II 473 Series									
22 ³ / ₄ "	19 ³ / ₄ "	33 ¹ / ₄ "	19"	17"	18 ¹ / ₄ "	17 ¹ / ₂ "	18 ¹ / ₄ "	17 ³ / ₄ "	10"

• Width • Between • Arms	• Arm • to • Floor	• Arm • Height • from • Seat	• Seat • Pan • Angle	• Angle • Between • Seat and • Back
--------------------------------	--------------------------	---------------------------------------	----------------------------	--

N.A.	N.A.	N.A.	8°	93°
------	------	------	----	-----

Max-Stacker II 473 Series Stackable Chairs



Standard Includes	Required to Specify
<ul style="list-style-type: none"> ▶ Need help? Product details, page 236 • Frame: seating coating or 9201 Polished Chrome • Back and seat: plastic • Tablet arm, if selected: laminate • Bookrack, if selected: high-wear coating or 9201 Polished Chrome • Glides: plastic 	<ul style="list-style-type: none"> 1 Style number 2 Seating coating color number for frame 3 Plastic color number for back and seat 4 Laminate color number for tablet arm 5 Options, if selected (see below) ▶ See <i>Surface Materials</i>, page 248.

Options	U.S. Price	Required to Specify
<p>Surface Materials</p> <p>Upholstered seat and back</p> <ul style="list-style-type: none"> • Fabric price group 1 +\$111 • Fabric price group 2 +\$131 • Fabric price group 3 +\$151 • Fabric price group 4 +\$166 • Fabric price group 5 +\$181 • Fabric price group 6 +\$196 • Fabric price group 7 +\$211 • Fabric price group 8 +\$236 • Fabric price group 9 +\$266 • Fabric price group 10 +\$286 • Customer's Own Material (COM) +\$141 • Soil-retardant treatment applied to upholstery fabric +\$ 20 		<ul style="list-style-type: none"> Add suffix U to the style number and specify fabric color number. Add suffix U to the style number and specify fabric color number. Add suffix U to the style number and specify fabric color number. Add suffix U to the style number and specify fabric color number. Add suffix U to the style number and specify fabric color number. Add suffix U to the style number and specify fabric color number. Add suffix U to the style number and specify fabric color number. Add suffix U to the style number and specify fabric color number. Add suffix U to the style number and specify fabric color number. Add suffix U to the style number and specify fabric color number. ▶ See <i>Surface Materials Reference Manual</i> to specify. Specify <i>with soil-retardant treatment</i>.
<p>Glides</p> <ul style="list-style-type: none"> • Soft glides for use on non-carpeted floors +\$ 6 		<ul style="list-style-type: none"> Specify <i>with soft glides</i>.

▶ Detailed dimensions, page 238

US

For **164** U.S., multiply all **162** U.S. prices by 1.03.
 Multiply **164** U.S. by 1.2 for **138** Canadian price.
 ▶ See page 1 for details.

Specification Information

• Frame Finish	• Style Number	• U.S. Base Price
----------------	----------------	-------------------

Without Arms

Coated frame	473410N	\$160
Polished Chrome frame	473410	\$160

With Tablet Arm

Right-Hand

Coated frame	473410NTR	\$279
Polished Chrome frame	473410TR	\$279

Left-Hand

Coated frame	473410NTL	\$279
Polished Chrome frame	473410TL	\$279

With Bookrack

Coated frame	473410NB	\$232
Polished Chrome frame	473410B	\$232

With Right-Hand Tablet Arm

Coated frame	473410NTRB	\$351
Polished Chrome frame	473410TRB	\$351

With Left-Hand Tablet Arm

Coated frame	473410NTLB	\$351
Polished Chrome frame	473410TLB	\$351



US 

For **164** U.S., multiply all **162** U.S. prices by 1.03.
Multiply **164** U.S. by 1.2 for **138** Canadian price.
▶ See page 1 for details.

Max-Stacker II 473 Series Accessories

Tablet Arm Assembly

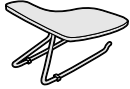

Standard Includes	Required to Specify
-------------------	---------------------

- | | |
|---|---|
| <ul style="list-style-type: none"> • Tablet arm frame: seating coating or 9201 Polished Chrome • Tablet arm worksurface: laminate | <ul style="list-style-type: none"> 1 Style number 2 Laminate color number 3 Color number for tablet arm frame ▶ See <i>Surface Materials</i>, page 248. |
|---|---|

Specification Information	
---------------------------	--

• Style Number	• U.S. Price
Right-Hand	
473TR	\$119
Left-Hand	
473TL	\$119

Bookrack Assembly



Standard Includes	Required to Specify
-------------------	---------------------

- | | |
|--|--|
| <ul style="list-style-type: none"> • Bookrack assembly: seating coating or 9201 Polished Chrome | <ul style="list-style-type: none"> 1 Style number 2 Color number for bookrack ▶ See <i>Surface Materials</i>, page 248. |
|--|--|

Specification Information	
---------------------------	--

• Style Number	• U.S. Price
473B	\$72

Alignment Device

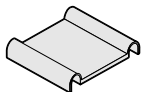

Standard Includes	Required to Specify
-------------------	---------------------

- | | |
|--|--|
| <ul style="list-style-type: none"> • Carton of 12 alignment devices: black plastic only | <ul style="list-style-type: none"> Style number |
|--|--|

Specification Information	
---------------------------	--

• Style Number	• U.S. Price
473G	\$26

US

For **164** U.S., multiply all **162** U.S. prices by 1.03.
 Multiply **164** U.S. by 1.2 for **138** Canadian price.
 ▶ See page 1 for details.

Transport and Storage Dolly

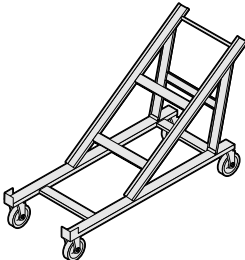

Standard Includes	Required to Specify
-------------------	---------------------

- | | |
|---|--------------|
| • Transport and storage dolly: black paint only | Style number |
|---|--------------|

Specification Information	
• Style Number	• U.S. Price

• Style Number	• U.S. Price
473D	\$396

Max-Stacker II 473 Series

US

For **164** U.S., multiply all **162** U.S. prices by 1.03.
 Multiply **164** U.S. by 1.2 for **138** Canadian price.
 ▶ See page 1 for details.



Specifying Seating Transitional Products

What is the Transitional Products chapter?

This *Transitional Products* chapter contains products that are being **maintained for existing customers only** and are likely to be phased out over time. It is expected that each of these Transitional items will enter the existing deletion process when and if a decision is made to discontinue production. These products are indicated with a **T**. Products that have a specific culling date are indicated with an **X**, followed by the last order entry date. A list of products and surface materials identified for deletion is included on Product Info. See the “Culling List With Alternatives.” Product Info is an electronic collection of specification guides in Acrobat PDF (Portable Document Format). With Product Info, you can scan, search, and print any page on virtually any computer. You can access these files at the Steelcase.com Web site or My Sales Online at in2.Steelcase.com. **New customers or existing customers with new projects should be selecting other products.**

The idea is to give you—our customers, designers, specifiers, and dealers—additional time to prepare for change. With this kind of advance notice, we'll be able to help you:

- make smooth transitions to alternative selections
- avoid selections that may be phased out over time
- be more informed and confident about the long-term plans for our products and surface materials

Multipurpose/Guest Chairs

Trilogy 421 Series

246

Trilogy 421 Series Sled-Base Multipurpose/Guest Chairs



Tip: Fire Code Seating (FCS) option is available with certain upholstery fabric choices only.

Standard Includes		Required to Specify	
<ul style="list-style-type: none"> Arm caps: black plastic Upholstery: fabric price group 1 Frame and arms, if selected: 9201 Polished Chrome 		<ul style="list-style-type: none"> 1 Style number 2 Fabric color number for upholstery 3 Options, if selected (see below) ▶ See <i>Surface Materials</i> in the electronic price list. 	
Surface Materials	Options	U.S. Price	Required to Specify
	Upholstery <ul style="list-style-type: none"> Fabric price group 1 Fabric price group 2 Fabric price group 3 Fabric price group 4 Fabric price group 5 Fabric price group 6 Fabric price group 7 Fabric price group 8 Fabric price group 9 Fabric price group 10 Leather price group Customer's Own Material (COM) or Customer's Own Leather (COL) Fire Code Seating (FCS) Soil-retardant treatment applied to upholstery fabric 	<ul style="list-style-type: none"> No cost +\$ 20 +\$ 40 +\$ 55 +\$ 70 +\$100 +\$140 +\$185 +\$220 +\$255 +\$450 +\$ 30 +\$ 55 +\$ 20 	<ul style="list-style-type: none"> Specify fabric color number. Specify fabric color number. Specify fabric color number. Specify fabric color number. Specify fabric color number. Specify fabric color number. Specify fabric color number. Specify fabric color number. Specify fabric color number. Specify fabric color number. Specify leather color number. ▶ See <i>Surface Materials Reference Manual</i> to specify. Add suffix F to the style number. Specify <i>with soil-retardant treatment</i>.
	Frame, base, and arms <ul style="list-style-type: none"> Monochromatic color 	<ul style="list-style-type: none"> No cost 	<ul style="list-style-type: none"> Add suffix M to chair style number and indicate plastic color number.

Specification Information

High Back



• Style Number
• U.S. Base Price

Standard Back



• Style Number
• U.S. Base Price

Standard Back



• Style Number
• U.S. Base Price

With Plastic Arm Caps

421492N  \$534

421482N  \$462

Without Arms

421480N  \$407

US 

For **164** U.S., multiply all **162** U.S. prices by 1.03.
Multiply **164** U.S. by 1.2 for **138** Canadian price.
▶ See page 1 for details.

Surface Materials

Surface Materials	248
Steelcase Classics Collection Upholstery Matrix	252
DesignTex Graded-In Seating Upholstery Matrix	253
Fire Code Seating Upholstery Matrix	254
Fire Code Seating Upholstery Matrix for DesignTex	255
Color Availability Matrix	256
Special Features	258

Surface Materials

This listing includes all the surface material choices that are available for the products in this specification guide

Resources

For more information about surface materials, refer to the following resources:

Additional surface materials specification tools are available to assist you in the specification process—the Surface Materials Binders and the Surface Materials Tool Box.

Surface Materials Binders

- Surface Materials Reference Manual
- A complete set of swatch cards for hard surfaces, vertical surface fabrics, and seating upholstery

Surface Materials Tool Box

(S8150) provides 3" x 3" samples of the following surface materials:

- Vertical surface fabrics
- Seating upholstery
- Wood veneer
- Paint
- Laminate

Plastic

Not every plastic color is available on every plastic component.

► Refer to the *Color Availability Matrix* on page 256 before specifying.

- 6205 Black
- 6206 Burgundy
- 6249 Platinum (solid)
- 6250 Coffee
- 6256 Graphite
- 6259 Midnight
- 6268 Navy
- 6296 Sterling
- 6301 Aegean
- 6302 Baltic
- 6303 Pomegranate
- 6421 Ash
- 6694 Slate

Seating Coating

Applies to:

- Parade! 470 Series
- Max-Stacker 472 Series
- Max-Stacker II 473 Series
- 7000 Black
- 7005 Coffee
- 7011 Graphite

Paint

Applies to:

- Jersey Series work chairs
 - 4799 Platinum (metallic paint)
- Applies to:
- Jersey Series guest chairs
 - 4799 Platinum (metallic paint)
 - 7207 Black

Metal

Metal finishes are not available on every chair.

- Refer to the *Color Availability Matrix* on page 256 before specifying.
- 8046 Polished Aluminum
 - 9201 Polished Chrome

Laminate

Not every laminate color is available on every chair.

► Refer to the *Color Availability Matrix* on page 256 before specifying.

- 2412 Natural Cherry
- 2422 Medium Cherry
- 2511 Winter on Maple
- 2632 Medium Oak
- 2714 Natural Walnut
- 2722 Cream
- 2746 Black
- 2759 Warm White
- 2772 Medium Mahogany on Walnut
- 2810 Dawn
- 2811 Mist

Wood

Applies to:

- Snodgrass 474 Series chair frames
- Tip: Frames are constructed of solid maple. Finishes applied to maple will match the color of stains applied to oak, walnut, or cherry, but will not show the same natural grain.*

Wood Seating Color Choices

- 3402 Clear Cherry (aged)
- 3412 Natural Cherry
- 3422 Medium Cherry
- 3522 Clear Maple*
- 3572 Amber on Maple
- 3592 Blonde on Maple
- 3602 Desert Oak
- 3612 Warm Oak
- 3622 Portabello Oak
- 3682 Dark Oak
- 3702 Clear Walnut
- 3712 Natural Walnut
- 3722 Dark Mahogany on Walnut
- 3752 Medium Walnut
- 3762 Dark Walnut
- 3772 Medium Mahogany on Walnut

**Because no stain is used in the clear-coat process, a sign-off will be required prior to orders being accepted for this finish. The sign-off sheet is available through Steelcase advertising stock. Form number 05-0001370*

Customiz stain is a service that allows you to create your own stain color. Minimum order quantities, per unit up-charges, and a one-time customer processing fee apply.

► See the *Surface Materials Reference Manual* for more information.

Wool Suede Too

Applies to:

- Leap 464 Series WorkLounge
- 101 Stone
- 102 Tan
- 103 Pecan
- 201 Sesame
- 301 Blush
- 302 Persimmon
- 303 Cranberry
- 401 Ink
- 402 Charcoal
- 403 China
- 501 Green Tea
- 502 Eucalyptus
- 503 Patina
- 504 Juniper
- 505 Olive
- 601 Jam
- 701 Squash
- 702 Ginger
- 801 Dust
- 802 Mineral
- 803 Shale
- 804 Black

Elmo Rustical Leather

Applies to:

- Leap 464 Series WorkLounge
- 04004 Suffron
- 12001 Mushroom
- 12011 Light Grey
- 17009 Wedgwood
- 17061 Lilac
- 18001 Gray Green
- 22679 Beige
- 33007 Brown
- 33286 Rust
- 43236 Camel
- 43632 Honey
- 45056 Sun Ray
- 48059 Field Green
- 53301 Red Brown
- 55057 Crimson
- 55063 Flame
- 57016 Deep Purple
- 87055 Azure
- 91722 Smoke
- 93287 Charbrown
- 93327 Loam
- 95060 Wine
- 97054 Twilight
- 97952 Deep Blue
- 98953 Mist Green
- 99991 Ebony

Elmo Soft Leather

Available on:

- Siento 499 Series
- L110 Maritime Blue
- L111 Midnight Blue
- L112 Ebony
- L113 Gunmetal
- L114 Mica
- L115 Dove Grey
- L116 Plum Pleasure
- L117 Passion Blue
- L118 French Blue
- L119 Cape Blue
- L120 Sky Blue
- L121 Pacific Blue
- L122 Truffle
- L123 Olive
- L124 Sea Breeze
- L125 Pine
- L126 Forest
- L127 Teal Green
- L128 Red Birch
- L129 Rosetta
- L130 Winesap
- L131 Crocus
- L132 Violet
- L133 Espresso
- L134 Ruby
- L135 Scarlet
- L136 Claret
- L137 Cabernet
- L138 Bourbon
- L139 Cinder
- L140 Garnet
- L141 Apricot
- L142 Melon
- L143 Pecan
- L144 Chamois
- L145 Palomino
- L146 Russet
- L147 Saddle
- L148 Goldstone
- L149 Saffron
- L150 Ivory
- L151 White

Mesh

Applies to:

- Jersey Series
- T084 Black
- T085 Grey
- T086 White
- T087 Yellow
- T088 Orange
- T089 Red
- T090 Green
- T091 Blue
- T094 Cardinal

Pullover

Applies to:

- Jersey Series
- T092 Black
- T095 Yellow
- T096 Orange
- T097 Red
- T098 Green
- T099 Blue

3D Knit

Applies to:

- Think 465 Series
- Leap 462 Series

5064 Black
5065 Coconut
5066 Malt
5067 Root Beer
5068 Charcoal
5069 Ink

Upholstery

Not every upholstery is available on every chair.

► Refer to the *Steelcase Classics Collection Upholstery Matrix* on page 252 before specifying.

Classics Collection

Surface materials in the Classics Collection are timeless. These materials should be available for a minimum of 10 years from the date the material is introduced into the Classics Collection. The Classics Collection includes the following fabrics in Price Groups 1 through 3 and the Leather Price Group:

Price Group 1**Buzz2**

5F00 Yellow
5F01 Camel
5F02 Orange
5F03 Tomato
5F04 Red
5F05 Burgundy
5F06 Sky
5F07 Blue
5F08 Navy
5F09 Blue-Green
5F10 Grape
5F11 Eggplant
5F12 Celery
5F13 Green
5F14 Forest
5F15 Stone
5F16 Grey
5F17 Black

Jacks

5B61 Taupe
5B62 Nutmeg
5B63 Camel
5B64 Pewter
5B65 Rosewood
5B66 Plum
5B67 Lupine
5B68 Lichen
5B69 Ocean
5B70 Midnight

Link

5A20 Burgundy
5A21 Rust
5A23 Green
5A24 Blue
5A25 Navy
5A26 Purple
5A27 Black
5A28 Ocean
5A29 Lichen
5A30 Chamois

Seating Vinyl

5800 Cardinal
5801 Topaz
5802 Ocean
5803 Sky
5804 Lupine
5805 Foggy Night
5806 Aegean
5807 Harbor
5808 Eggplant
5809 Black
5810 Forest
5812 Navy
5813 Currant

Price Group 2**Cricket**

5A84 Plum
5A85 Camel
5A86 Charcoal
5A87 Black
5A88 Cinnamon
5A89 Rosewood
5A90 Currant
5A91 Spearmint
5A92 Sky
5A93 Midnight
5A94 Lichen
5A95 Ocean
5A96 Forest

Regis

5267 Black
5275 Blue Blue Violet
5282 Blue Blue Green
5283 Blue
5R02 Cardinal
5R11 Red Red Violet V5
5R12 Pachysandra
5R13 Celestial
5R16 Caribbean
5R17 Topaz

Roulette

5D29 Ocean
5D30 Taupe
5D31 Pewter
5D32 Sky
5D33 Cinnamon
5D34 Rosewood
5D35 Plum
5D36 Spearmint
5D37 Forest
5D38 Midnight

Spyder

5B00 Orchid
5B01 Foggy Night
5B04 Peri
5B05 Merlot
5B06 Dove
5B07 Sage
5B09 Topaz
5B10 Ocean
5B11 Currant
5B12 Lichen

Price Group 3**Hampstead**

B351 Blue Green V4
B359 Blue Blue Green V5
B361 Blue V3 (Low Intensity)
B363 Blue V4
B366 Blue Blue Violet V4
B369 Blue Blue Violet V5
B377 Violet V5 (Low Intensity)
B386 Red Red Violet V4 (Low Intensity)
B389 Red Red Violet V5
B395 Grey V5
B399 Black
B406 Windflower
B407 Twinflower
B408 Lupine
B409 Cornflower
B410 Aegean
B412 Starflower
B413 Shale
B415 Taupe
B416 Topaz
B417 Saddle
B418 Paprika
B419 Cinnamon
B420 Apple
B421 Leaf

Zoe

5A09 Apricot
5A10 Eggplant
5A11 Avocado
5A12 Cinnamon
5A14 Peacock
5A15 Rain
5A16 Grey Flannel
5A17 Ivory Cream
5A19 Currant

Leather Price Group

L107 Black
L202 Dusk
L203 Bottle
L207 Mahogany
L220 Soapstone
L221 Rocky
L224 Plum
L500 Camel
L503 Navy
L507 Vineyard

Designtex Graded-In Program

All Designtex Graded-In fabrics are now supported just like standard fabrics when ordered on Steelcase furniture. The Designtex Graded-In Program also includes the Environmental Impact Collection which offers sustainable textiles in affordable price groups. For additional information and fabric samples, contact your local Designtex sales representative at 1.800.221.1540.

Designtex upholsteries are graded into Steelcase Price Groups 2 through 10:

Price Group 2**Bee (Environmental Impact Collection)**

5E44 Caspian
5E45 Chamois
5E46 Nutmeg
5E47 Java
5E48 Cinnamon
5E49 Laquer
5E50 Currant
5E51 Lupine
5E52 Prune
5E53 Aubergine
5E54 Sky
5E55 Cadet
5E56 Midnight
5E57 Khaki
5E58 Stem
5E59 Pine
5E60 Pond
5E61 Tuscan
5E62 Forest
5E63 Taupe
5E64 Pewter
5E65 Raven

Price Group 3**Lagoon (Environmental Impact Collection)**

5D80 Pond
5D81 Chamois
5D82 Willow
5D83 Java
5D84 Nutmeg
5D85 Cinnamon
5D86 Currant
5D87 Opal
5D88 Crocus
5D89 Aubergine
5D90 Mist
5D91 Cadet
5D92 Midnight
5D93 Lichen
5D94 Spearmint
5D95 Forest
5D96 Sage
5D97 Charcoal
5D98 Raven

Prairie (Environmental Impact Collection)

5E66 Plum
5E67 Chamois
5E68 Pewter
5E69 Dark Taupe
5E70 Doe
5E71 Luggage
5E72 Java
5E73 Mandarin
5E74 Cinnabar
5E75 Currant
5E76 Watermelon
5E77 Lupine
5E78 Aubergine
5E79 Lichen
5E80 Stem
5E81 Forest
5E82 Sage
5E83 Ocean
5E84 Kale
5E85 Cadet
5E86 Sky
5E87 Midnight
5E88 Charcoal
5E89 Cinder
5E90 Raven

Reed Stripe (Environmental Impact Collection)

5D55 Java
5D56 Willow
5D57 Camel
5D58 Charcoal
5D59 Lichen
5D60 Pond
5D61 Cadet
5D62 Nutmeg
5D63 Paprika
5D64 Currant
5D65 Ocean
5D66 Midnight
5D67 Forest

Surface Materials, continued

Price Group 4

Bowline

- J568 Canyon
- J569 Beach
- J570 Paprika
- J571 Ocean
- J572 Leaf
- J573 Midnight
- J574 Smoke

Closed Loop

- J589 Sand
- J590 Taupe
- J591 Saffron
- J592 Redwood
- J593 Lapis
- J594 Indigo
- J595 Robin's Egg
- J596 Willow
- J597 Malachite
- J598 Forest
- J599 Jade
- J600 Mahogany
- J601 Amethyst
- J602 Tangerine
- J603 Mineral
- J604 Black

Cord

- J582 Canyon
- J583 Beach
- J584 Paprika
- J585 Ocean
- J586 Leaf
- J587 Midnight
- J588 Smoke

Domino

- 5C34 Ocean
- 5C35 Camel
- 5C36 Charcoal
- 5C37 Pewter
- 5C38 Plum
- 5C39 Rosewood
- 5C40 Cinnamon
- 5C41 Sky
- 5C42 Midnight
- 5C43 Forest

Montezuma

- J335 Adobe
- J336 Jack Rabbit
- J337 Palomino
- J338 Tumbleweed
- J339 Citrus
- J340 Chili
- J341 Salsa
- J342 Cornflower
- J343 Azul
- J344 Lapis
- J345 Aqua
- J346 Peacock
- J347 Peyote
- J348 Verde
- J349 Cactus
- J350 Cilantro
- J351 Thistle
- J352 Rosa
- J353 Aztec
- J354 Canyon
- J355 Clay
- J356 Antler
- J357 Pewter
- J358 Charcoal
- J359 Onyx

Nolita

- J605 Almond
- J606 Earth
- J607 Sesame
- J608 Sunflower
- J609 Cherry
- J610 Cobalt
- J611 Glacier
- J612 Clover
- J613 Spruce
- J614 Iris
- J615 Terracotta
- J616 Graphite
- J617 Carbon

Round About

- J575 Canyon
- J576 Beach
- J577 Paprika
- J578 Ocean
- J579 Leaf
- J580 Midnight
- J581 Smoke

Skittles

- 5D42 Ocean
- 5D43 Taupe
- 5D44 Camel
- 5D45 Nutmeg
- 5D46 Lichen
- 5D47 Sky
- 5D48 Charcoal
- 5D49 Plum
- 5D50 Paprika
- 5D51 Currant

Tango

- J081 Neutra
- J082 Deer
- J083 Elephant
- J084 Pascal
- J085 Borolo
- J086 Cosmos
- J087 Aegean
- J088 Ink
- J089 Aloe
- J090 Sherwood
- J091 Currant
- J092 Squash
- J093 Salt
- J094 Pepper

Tivoll

- 5C80 Spearmint
- 5C81 Camel
- 5C82 Almond
- 5C83 Pewter
- 5C84 Nutmeg
- 5C85 Cinnamon
- 5C86 Currant
- 5C87 Lichen
- 5C88 Plum
- 5C89 Sky

Vibe

- J548 Coconut
- J549 Sand
- J550 Malt
- J551 Root Beer
- J552 Champagne
- J553 Papaya
- J554 Cherry
- J555 Pool
- J556 Petal
- J557 Ocean
- J558 Slate
- J559 Key Lime
- J560 Palm Tree
- J561 Jam
- J562 Huckleberry
- J563 Sunrise
- J564 Snow Cone
- J565 Green Tea
- J566 Charcoal
- J567 Licorice
- J659 Ink

Wobble

- 5D16 Rosewood
- 5D17 Cinnamon
- 5D18 Paprika
- 5D19 Pewter
- 5D20 Camel
- 5D21 Lichen
- 5D22 Ocean
- 5D23 Sky
- 5D24 Plum
- 5D25 Midnight

Price Group 5

Abex

- J424 Dust
- J425 Rust
- J426 Chili Sauce
- J427 Titanic
- J428 Jungle
- J429 Amazon
- J430 Grape Slush

Frisbee

- 5C67 Sage
- 5C68 Chamois
- 5C69 Camel
- 5C70 Nutmeg
- 5C71 Spearmint
- 5C72 Ocean
- 5C73 Lichen
- 5C74 Sky
- 5C75 Plum
- 5C76 Midnight

Retreat

- 5D68 Taupe
- 5D69 Camel
- 5D70 Charcoal
- 5D71 Mist
- 5D72 Violet
- 5D73 Midnight
- 5D74 Spearmint
- 5D75 Lichen
- 5D76 Forest
- 5D77 Nutmeg
- 5D78 Cinnamon
- 5D79 Currant

Sam

- J360 Pebble
- J361 Cornsilk
- J362 Yolk
- J363 Ladybug
- J364 Cherry
- J365 Sky
- J366 Bluejay
- J367 Grass
- J368 Sweetpea
- J369 Jam
- J370 Grape
- J371 Goldfish
- J372 River
- J373 Stone

Price Group 6

Rough & Ready

- J431 Wheat
- J432 Field
- J433 Sand
- J434 Squirrel
- J435 Mink
- J436 Sun
- J437 Lemon
- J438 Pepper
- J439 Wine
- J440 Ink
- J441 Octopus
- J442 Icy
- J443 Cobalt
- J444 Lagoon
- J445 Brook
- J446 Kale
- J447 Leaf
- J448 Sprout
- J449 Concord
- J450 Raisin
- J451 Tiger
- J452 Cinnamon
- J453 Toffee
- J454 Whale
- J455 Stone
- J456 Tar

Price Group 7

Ace

- J502 Beige
- J503 Camel
- J504 Red
- J505 Orange
- J506 Black
- J507 Gray

Firefly

- J250 Ash
- J251 Cashew
- J252 Currant
- J253 Firebee
- J254 Bleu
- J255 Riviera
- J256 Citrine
- J257 Verdant
- J258 Sherwood
- J259 Charcoal

Shimmy

- J106 Wheat
- J107 Lark
- J108 Amber
- J109 Chili
- J110 Moroccan
- J111 Artichoke
- J112 Foliage
- J113 Mulberry
- J114 Canyon
- J115 Feather
- J116 Storm

Wool Suede Too

J457	Stone
J458	Tan
J459	Squash
J460	Blush
J461	Dust
J462	Mineral
J463	Sesame
J464	Ginger
J465	Eucalyptus
J466	Patina
J467	Green Tea
J468	Pecan
J469	China
J470	Juniper
J471	Olive
J472	Persimmon
J473	Charcoal
J474	Ink
J475	Jam
J476	Cranberry
J477	Shale
J478	Black

Price Group 8**Coppice**

J374	Vanilla
J375	Mushroom
J376	Straw
J377	Cardinal
J378	Volcano
J379	Cornflower
J380	Marine
J381	Larkspur
J382	Regiment
J383	Ivy
J384	African Violet
J385	Inca
J386	Kangaroo
J387	Gunmetal
J388	Pewter

Delphos

J117	Silver Birch
J118	Champagne
J119	Amber
J120	Cedar
J121	Cranberry
J122	Marina
J123	Blue Spruce
J124	Hyacinth
J125	Cypress
J126	Ultra Violet
J127	Damson
J128	Flat Iron

Falling Leaves

J314	Acorn
J315	Barn
J316	Spring
J317	Forest
J318	Meadow
J319	Autumn

Furrows

J320	Vanilla
J321	Mushroom
J322	Koala
J323	Straw
J324	Cardinal
J325	Volcano
J326	Cornflower
J327	Marine
J328	Larkspur
J329	Regiment
J330	Ivy
J331	African Violet
J332	Inca
J333	Kangaroo
J334	Gunmetal

Lillian

J268	Silver Birch
J269	Champagne
J270	Butternut
J271	Cedar
J272	Marina
J273	Blue Spruce
J274	Hunter
J275	Cypress
J276	Hyacinth
J277	Flat Iron

Loseta

J389	Straw
J390	Persimmon
J391	Cassis
J392	Bluestone
J393	Briar
J394	Crocus
J395	Shale
J396	Cattail

Meander

J397	Mushroom
J398	Straw
J399	Volcano
J400	Volcano Ivy
J401	Marine
J402	Larkspur
J403	Regiment Volcano
J404	Regiment
J405	Ivy
J406	Regiment Ivy
J407	Violey Ivy
J408	Inca Ivy
J409	Kangaroo
J410	Gunmetal
J411	Pewter

Packard

J412	Porcelain
J413	Loden
J414	Camel
J415	Brass
J416	Pimpernel
J417	Gemstone
J418	Lapis
J419	Leaf
J420	Mint
J421	Patina
J422	Plum
J423	Cricket

Rickshaw

J479	Driftwood
J480	Ochre
J481	Cherry
J482	Midnight
J483	Pistachio
J484	Dusk
J485	Paprika

Price Group 9**Gramercy**

J647	Fawn
J648	Chocolate
J649	Stag
J650	Cordovan
J651	Claret
J652	Brook
J653	Navy
J654	Moss
J655	Bottle
J656	Hunter
J657	Brick
J658	Coal

NoMad

J486	Lager
J487	Peaches-n-Cream
J488	Tangerine
J489	Green Mint
J490	Limeade
J491	Smudge
J492	Sea Breeze
J493	Ice Blast
J494	Root Beer

Price Group 10**Plums**

J495	Fieldstone
J496	Celery
J497	Penny
J498	Pond
J499	Mulberry
J500	Iris
J501	Boysenberry

► See the *Surface Materials Reference Manual* for a listing of upholstery colors.

Price Group COM/COL**(Customer's Own Material/Leather)****Fabric Approval and Yardage**

To confirm whether a particular COM material has already been tested for use on a specific Steelcase product or to determine actual yardage requirements:

- Visit www.steelcase.com
- Click on "Knowledge & Design"
- Select "Customer's Own Material"

For additional information regarding Customer's Own Material, call

1.888.STEELCASE.

Steelcase Classics Collection Upholstery Matrix



	Ally 463 Series	Cachet 487 Series	Criterion 453 Series	Criterion Plus 453 Series	Drive 461 Series	Jersey Series	Leap 462 Series	Leap 464 Series WorkLounge	Max-Stacker II 473 Series	Move 490 Series	Paradel 470 Series	Player 475 Series	Protegé 433 Series	Rally 457 Series	Sensor 458 Series	Siento 499 Series	Snodgrass 474 Series	Think 465 Series
Classics Collection																		
Buzz2 Price Group 1	■	■	■	■	■	■	■	•	■	■	■	■	■	■	■	■	■	■
Cricket Price Group 2	■	■	■	■	■	•	■	•	■	■	■	■	■	■	■	■	■	■
Hampstead Price Group 3	■	■	■	■	■	•	■	•	■	■	■	■	■	■	■	■	■	■
Jacks Price Group 1	■	■	■	■	■	•	■	•	■	■	■	■	■	■	■	•	■	■
Link Price Group 1	■	■	■	■	■	•	■	•	■	■	■	■	■	■	■	•	■	■
Regis Price Group 2	■	■	■	■	■	•	■	•	■	■	■	■	■	■	■	■	■	■
Roulette Price Group 2	■	■	■	■	■	•	■	•	■	■	■	■	■	■	■	•	■	■
Spyder Price Group 2	■	■	■	■	■	•	■	•	■	■	■	■	■	■	■	•	■	■
Leather Leather	■	■	•	■	■	•	■	•	■	•	■	•	■	■	■	•	■	■
Seating Vinyl Price Group 1	■	■	■	■	■	•	■	•	■	■	■	■	■	■	■	•	■	■
Zoe Price Group 3	■	■	■	■	■	•	■	•	■	■	■	■	■	■	■	•	■	■
Other Upholstery																		
Elmo Rustical Leather	•	•	•	•	•	•	•	■	•	•	•	•	•	•	•	•	•	•
Elmo Soft Leather	•	•	•	•	•	•	•	•	•	•	•	•	•	•	•	■	•	•
Jersey Mesh	•	•	•	•	•	■	•	•	•	•	•	•	•	•	•	•	•	•
Jersey Stretch Pullover	•	•	•	•	•	■	•	•	•	•	•	•	•	•	•	•	•	•
3D Knit	•	•	•	•	•	•	■	•	•	•	•	•	•	•	•	•	•	■

Jersey Series is available with black fabric or black leather seat. Buzz2 or COM may be specified as an option on fabric seat models. The back rest is standard with mesh (available in 9 colors) or with an optional stretch pullover (available in 6 colors).
▶ See page 248 for mesh and pullover colors.

Leap 464 Series WorkLounge is standard with Designtex Wool Suede Too. Elmo Rustical leather is an option.

- Legend**
- = Not available
 - = Available
 - = Available with exceptions
 - ▶ See specification pages for details.

Designtex Graded-In Seating Upholstery Matrix

Designtex Graded-In Seating Upholstery Matrix



	Ally 463 Series	Cachet 487 Series	Criterion 453 Series	Criterion Plus 453 Series	Drive 461 Series	Jersey Series	Leap 462 Series	Leap 464 Series WorkLounge	Max-Stacker II 473 Series	Move 490 Series	Paradei 470 Series	Player 475 Series	Protegé 433 Series	Rally 457 Series	Sensor 458 Series	Siento 499 Series	Snodgrass 474 Series	Think 465 Series
Environmental Impact Collection																		
Bee Price Group 2	■	■	■	■	■	•	■	•	■	■	■	■	■	■	■	■	■	■
Lagoon Price Group 3	■	■	■	■	■	•	■	•	■	■	■	■	■	■	■	■	■	■
Prairie Price Group 3	■	■	■	■	■	•	■	•	■	■	■	■	■	■	■	■	■	■
Reed Stripe Price Group 3	■	■	•	■	•	•	■	•	■	■	■	■	■	■	•	•	■	■
Other Seating Upholstery																		
Abex Price Group 5	■	■	■	■	•	•	■	•	■	■	■	■	■	■	■	•	■	■
Ace Price Group 7	■	■	■	■	■	•	■	•	■	■	■	■	■	■	•	•	■	■
Bowline Price Group 4	■	■	•	■	■	•	■	•	■	■	■	■	■	■	■	•	■	■
Closed Loop Price Group 4	■	■	■	■	■	•	■	•	■	■	■	■	■	■	■	■	■	■
Coppice Price Group 8	■	■	■	■	■	•	■	•	■	•	■	■	■	■	■	■	■	■
Cord Price Group 4	•	■	•	■	•	•	■	•	■	■	■	■	■	■	■	■	■	■
Delphos Price Group 8	■	■	■	■	■	•	■	•	■	•	■	■	■	■	■	•	■	■
Domino Price Group 4	■	■	■	■	■	•	■	•	■	■	■	■	■	■	■	•	■	■
Falling Leaves Price Group 8	■	■	■	■	■	•	■	•	■	■	■	■	■	■	•	•	■	■
Firefly Price Group 7	■	■	■	■	•	•	■	•	■	■	■	■	■	■	•	•	■	■
Frisbee Price Group 5	■	■	•	■	■	•	■	•	■	•	■	■	■	■	•	•	■	■
Furrows Price Group 8	■	■	■	■	•	•	■	•	■	•	■	■	■	■	•	•	■	■
Gramercy Price Group 9	■	■	■	■	■	•	■	•	■	■	■	■	■	■	•	•	■	■
Lillian Price Group 8	■	■	■	■	■	•	■	•	■	•	■	■	■	■	■	•	■	■
Loseta Price Group 8	■	■	■	■	■	•	■	•	■	■	■	■	■	■	■	•	■	■
Meander Price Group 8	■	■	■	■	■	•	■	•	■	■	■	■	■	■	■	•	■	■
Montezuma Price Group 4	■	■	■	■	■	•	■	•	■	•	■	■	■	■	■	■	■	■
Nolita Price Group 4	•	■	•	■	•	•	•	•	•	•	■	•	•	•	•	•	■	•
NoMad Price Group 9	■	■	•	■	•	•	■	•	■	■	■	■	■	■	•	•	■	■
Packard Price Group 8	■	■	■	■	■	•	■	•	■	■	■	■	■	■	■	■	■	■
Plums Price Group 10	■	■	•	■	•	•	■	•	■	■	■	■	■	•	•	•	■	■
Retreat Price Group 5	■	■	■	■	■	•	■	•	■	■	■	■	■	■	■	•	■	■
Rickshaw Price Group 8	■	■	•	■	•	•	■	•	■	■	■	■	■	■	■	•	■	■
Rough & Ready Price Group 6	■	■	■	■	■	•	■	•	■	■	■	■	■	■	•	•	■	■
Round About Price Group 4	■	■	•	■	•	•	■	•	■	■	■	■	■	■	•	•	■	■
Sam Price Group 5	■	■	■	■	■	•	■	•	■	•	■	■	■	■	■	•	■	■
Shimmy Price Group 7	■	■	■	■	•	•	■	•	■	•	■	■	■	■	•	•	■	■
Skittles Price Group 4	■	■	■	■	■	•	■	•	■	■	■	■	■	■	■	•	■	■
Tango Price Group 4	■	■	■	■	■	•	■	•	■	■	■	■	■	■	■	■	■	■
Tivoli Price Group 4	■	■	•	■	•	•	■	•	■	•	■	■	■	■	•	•	■	■
Vibe Price Group 4	■	■	■	■	■	•	■	•	■	■	■	■	■	■	■	■	■	■
Wobble Price Group 4	■	■	•	■	•	•	■	•	■	•	■	■	■	■	•	•	■	■
Wool Suede Too Price Group 7	■	■	■	■	■	•	■	■	■	■	■	■	■	■	■	■	■	■

Legend

- = Not available
- = Available
- = Available with exceptions
- ▶ See specification pages for details.

Surface Materials

Fire Code Seating Upholstery Matrix

Fire Code Seating (FCS) indicates that a product is constructed to meet the strict fire code requirements of high public occupancy areas.

The following matrix lists each seating line and denotes fabrics that are available, available with exceptions, and not available.

For further detail regarding exceptions, see the specific chapter within the *Seating Specification Guide* or the *Surface Materials Reference Manual*.

	Fabric Price Group	Ally 463 Series	Cachet 487 Series	Criterion 453 Series	Criterion Plus 453 Series	Drive 461 Series	Jersey Series	Leap 462 Series	Leap 464 Series Worklounge	Max-Stacker 472 Series	Max-Stacker II 473 Series	Move 490 Series	Parade! 470 Series	Player 475 Series	Protegé 433 Series	Rally 457 Series	Sensor 458 Series	Siento 499 Series	Snodgrass 474 Series	Think 465 Series
Buzz2	1	■	•	□	•	•	•	■	•	•	•	•	•	■	•	•	•	•	□	■
Cricket	2	■	•	□	•	•	•	■	•	•	•	•	•	■	•	•	•	•	□	■
Hampstead	3	■	■	□	□	■	•	■	•	•	•	•	•	■	■	■	□	•	□	■
Jacks	1	■	■	□	□	•	•	■	•	•	•	•	•	■	■	■	□	•	□	■
Link	1	■	■	□	□	•	•	■	•	•	•	•	•	■	■	■	□	•	□	■
Regis	2	■	■	□	•	■	•	•	•	•	•	•	•	■	■	■	□	•	□	•
Roulette	2	•	•	□	•	■	•	•	•	•	•	•	•	■	■	■	□	•	□	•
Seating Vinyl	1	•	■	□	•	•	•	■	•	•	•	•	•	■	■	■	•	•	□	•
Spyder	2	■	■	□	•	•	•	■	•	•	•	•	•	■	■	■	□	•	□	■
Sweepstakes	2	■	■	□	•	■	•	•	•	•	•	•	•	■	■	■	□	•	□	•
Zoe	3	•	•	□	•	•	•	•	•	•	•	•	•	■	■	■	□	•	□	•
Leather	Leather	■	•	•	•	■	•	■	•	•	•	•	•	•	■	■	•	•	□	□
3D Knit		•	•	•	•	•	•	■	•	•	•	•	•	•	•	•	•	•	•	■

Criterion and Criterion Plus models meet fire code requirements only when specified with adjustable seat depth and 6205 Black plastic.

Sensor models meet fire code requirements only when specified with 6205 Black plastic.

Snodgrass models meet fire code requirements except for models with enclosed arms.

Legend

- = Not available
- = Available
- = Available with exceptions
- ▶ See specification pages for details.

Fire Code Seating Upholstery Matrix for Designtex

Designtex Graded-In

Fire Code Seating
Upholstery Matrix for
Designtex
Designtex Graded-In

	Ally 463 Series	Cachet 487 Series	Criterion 453 Series	Criterion Plus 453 Series	Drive 461 Series	Jersey Series	Leap 462 Series	Leap 464 Series Worklounge	Max-Stacker II 473 Series	Move 490 Series	Paradel 470 Series	Player 475 Series	Protegé 433 Series	Rally 457 Series	Sensor 458 Series	Siento 499 Series	Snodgrass 474 Series	Think 465 Series
Environmental Impact Collection																		
Bee Price Group 2	■	•	□	•	•	•	■	•	•	•	•	■	•	•	•	•	□	■
Lagoon Price Group 3	■	•	□	•	•	•	■	•	•	•	•	■	•	•	•	•	□	■
Prairie Price Group 3	■	•	□	•	•	•	•	•	•	•	•	■	•	•	•	•	□	■
Reed Stripe Price Group 3	■	•	•	•	•	•	■	•	•	•	•	■	•	•	•	•	□	■
Other Seating Upholstery																		
Abex Price Group 5	•	•	•	•	•	•	•	•	•	•	•	•	•	•	•	•	•	•
Ace Price Group 7	•	•	•	•	•	•	•	•	•	•	•	•	•	•	•	•	•	•
Bowline Price Group 4	•	•	•	•	•	•	•	•	•	•	•	•	•	•	•	•	•	•
Closed Loop Price Group 4	■	•	□	•	•	•	■	•	•	•	•	■	•	•	•	•	□	■
Coppice Price Group 8	•	•	•	•	•	•	•	•	•	•	•	•	•	•	•	•	•	•
Cord Price Group 4	•	•	•	•	•	•	■	•	•	•	•	■	•	•	•	•	□	■
Delphos Price Group 8	•	•	□	•	•	•	•	•	•	•	•	•	•	•	•	•	•	•
Domino Price Group 4	■	•	□	•	•	•	■	•	•	•	•	■	•	•	•	•	□	■
Falling Leaves Price Group 8	•	•	•	•	•	•	•	•	•	•	•	•	•	•	•	•	•	•
Firefly Price Group 7	•	•	•	•	•	•	•	•	•	•	•	•	•	•	•	•	•	•
Frisbee Price Group 5	•	•	•	•	•	•	•	•	•	•	•	•	•	•	•	•	□	•
Furrows Price Group 8	•	•	•	•	•	•	•	•	•	•	•	•	•	•	•	•	•	•
Gramercy Price Group 9	•	■	□	•	■	■	•	•	•	•	■	•	•	•	•	•	□	■
Lillian Price Group 8	•	•	•	•	•	•	•	•	•	•	•	•	•	•	•	•	•	•
Loseta Price Group 8	•	•	•	•	•	•	•	•	•	•	•	•	•	•	•	•	•	•
Meander Price Group 8	■	■	□	•	■	•	■	•	•	•	•	■	■	■	□	•	□	■
Montezuma Price Group 4	■	■	□	•	■	•	•	•	•	•	•	■	■	■	□	•	□	•
Nolita Price Group 4	•	•	•	•	•	•	•	•	•	•	•	•	•	•	•	•	•	•
NoMad Price Group 9	•	•	•	•	•	•	•	•	•	•	•	•	•	•	•	•	•	•
Packard Price Group 8	■	■	□	•	■	•	■	•	•	•	•	■	■	■	□	•	□	■
Plums Price Group 10	•	•	•	•	•	•	•	•	•	•	•	•	•	•	•	•	•	•
Retreat Price Group 5	•	•	□	•	•	•	•	•	•	•	•	•	•	•	•	•	•	•
Rickshaw Price Group 8	•	•	•	•	•	•	•	•	•	•	•	•	•	•	•	•	•	•
Rough & Ready Price Group 6	•	•	•	•	•	•	•	•	•	•	•	•	•	•	•	•	•	•
Round About Price Group 4	■	•	•	•	•	•	■	•	•	•	•	■	•	•	•	•	□	■
Sam Price Group 5	•	•	•	•	•	•	•	•	•	•	•	•	•	•	•	•	•	•
Shimmy Price Group 7	•	•	•	•	•	•	•	•	•	•	•	•	•	•	•	•	•	•
Skittles Price Group 4	•	•	□	•	•	•	•	•	•	•	•	■	■	■	□	•	□	•
Tango Price Group 4	■	•	□	•	•	•	■	•	•	•	•	■	•	•	•	•	□	■
Tivoli Price Group 4	•	•	•	•	•	•	•	•	•	•	•	•	•	•	•	•	□	•
Vibe Price Group 4	■	•	•	•	•	•	■	•	•	•	•	■	•	•	•	•	□	■
Wobble Price Group 4	■	•	•	•	•	•	•	•	•	•	•	■	•	•	•	•	□	■
Wool Suede Too Price Group 7	■	■	□	•	■	•	■	•	•	•	•	■	■	■	□	•	□	■

Criterion and Criterion Plus models meet fire code requirements only when specified with adjustable seat depth and 6205 Black plastic.

Sensor models meet fire code requirements only when specified with 6205 Black plastic.

Snodgrass models meet fire code requirements except for models with enclosed arms.

Legend

- = Not available
- = Available
- = Available with exceptions
- ▶ See specification pages for details.

Color Availability Matrix

Legend

- = Not available
- = Available
- = Available with exceptions
- ▶ See specification pages for details.

		Plastic											Metal						Paint		
		6009	6205	6206	6249	6250	6256	6259	6268	6296	6301	6302	6303	6421	6694	8046	9201	0835	4799	7207	
		Arctic White	Black	Burgundy	Platinum (solid)	Coffee	Graphite	Midnight	Navy	Sterling	Aegean	Baltic	Pomegranate	Ash	Slate	Polished Aluminum	Polished Chrome	Black	Platinum Metallic	Black	
Ally 463 Series	Outer seat, back, and arms	•	•	•	•	•	•	•	•	•	•	•	•	•	•	•	•	•	•	•	•
	Frame	•	■	•	•	•	•	■	•	■	•	•	•	•	•	•	•	•	•	•	•
Cachet 487 Series	Swivel and 4-leg frame	•	■	•	•	•	•	■	•	•	•	•	•	■	•	•	•	•	•	•	•
	Stool frame	•	■	•	•	•	•	•	•	•	•	•	•	•	•	•	•	•	•	•	•
Criterion 453 Series	Base, arms, outer seat and back, casters	•	■	•	•	■	■	•	•	•	•	•	•	•	•	•	•	•	•	•	•
	Foot ring	•	■	•	•	■	■	•	•	•	•	•	•	•	•	•	■	•	•	•	•
Drive 461 Series	Base, arms, faceplate, outer seat and back, casters	•	■	•	•	•	■	•	•	•	•	•	•	•	•	•	•	•	•	•	•
	Work chair	•	•	•	•	•	•	•	•	•	•	•	•	•	•	•	•	•	■	■	■
Jersey Series	Guest chair	•	•	•	•	•	•	•	•	•	•	•	•	•	•	•	•	•	■	■	■
	Base, outer seat and back foot ring	•	■	•	■	•	•	■	•	•	•	•	•	•	•	■	•	•	•	•	•
Leap 462 Series	Arms	•	■	•	•	•	•	•	•	•	•	•	•	•	•	•	•	•	•	•	•
	Backframe, arm supports, and base	•	•	•	•	•	•	•	•	•	•	•	•	•	•	■	•	•	•	•	•
Max-Stacker 472 and 473 Series	Frame and bookrack	•	•	•	•	•	•	•	•	•	•	•	•	•	•	•	■	•	•	•	•
	Seat and back	•	■	■	•	■	■	•	■	•	■	■	■	•	•	•	•	•	•	•	•
	Tablet arm	•	•	•	•	•	•	•	•	•	•	•	•	•	•	•	•	•	•	•	•
Move 490 Series	Frame	•	•	•	•	•	•	•	•	•	•	•	•	•	•	•	•	■	■	•	•
	Back shell and arms	■	■	•	•	•	•	■	•	•	•	•	•	•	•	•	•	•	•	•	•
Parade! 470 Series	Frame	•	•	•	•	•	•	•	•	•	•	•	•	•	•	•	■	•	•	•	•
	Seat and back	•	■	■	•	■	■	•	■	•	■	■	■	•	•	•	•	•	•	•	•
	Arm caps	•	■	■	•	■	■	•	■	•	■	■	■	•	•	•	•	•	•	•	•
Player 475 Series	Frame on chairs with smooth arms	•	■	•	•	■	■	•	•	•	•	•	•	•	•	•	•	•	•	•	•
	Smooth arms	•	■	•	•	■	■	•	•	•	•	•	•	•	•	•	•	•	•	•	•
	Frame on chairs with textured arms	•	■	•	•	•	■	•	•	•	•	•	•	•	•	•	•	•	•	•	•
	Textured arms	•	■	•	•	•	■	•	•	•	•	•	•	•	•	•	•	•	•	•	•
Protegé 433 Series	Tablet arm	•	•	•	•	•	•	•	•	•	•	•	•	•	•	•	•	•	•	•	•
	Base, arms, arm caps, outer back, sled base, and casters	•	■	•	•	■	■	•	•	•	•	•	•	•	•	•	•	•	•	•	•
Rally 457 Series	Base, arms, outer seat and back, casters	•	■	•	•	■	■	•	•	•	•	•	•	•	•	•	•	•	•	•	•
Sensor 458 Series	Base, arms, outer seat and back, foot ring, casters	•	■	•	•	■	■	•	•	•	•	•	•	•	•	•	•	•	•	•	•
	Sled base	•	■	•	•	■	■	•	•	•	•	•	•	•	•	•	•	•	•	•	•
Siento 499 Series	Base and arm supports	•	•	•	•	•	•	•	•	•	•	•	•	•	•	■	•	•	■	■	•
Snodgrass 474 Series	Frame	•	■	•	•	■	■	•	•	•	•	•	•	•	•	•	•	•	•	•	•
Think 465 Series	Base	•	■	•	•	•	•	•	•	•	•	•	•	•	■	■	•	•	•	•	•
	Back frame, arm supports, seat shell	•	■	•	•	•	•	•	•	•	•	•	•	•	■	•	•	•	•	•	•
	Arm caps, headrest, controls, casters	•	■	•	•	•	•	•	•	•	•	•	•	•	•	•	•	•	•	•	•

Special Features

This chart provides general guidelines about some of the types of special features that are available.

	Different fabric on seat and back	Headrest	Sewn seam using vinyl or leather	Thicker seat cushion	Special seat height *	Special seat height base assemblies for field installation	Stool base	Jury base	Glides	Braking or reverse braking casters	High-performance arm	Oversized tablet arm	Corporate logo
Ally 463 Series	■	•	∅	•	•	•	•	∅	∅	•	•	•	•
Cachet 487 Series	■	•	•	•	■	■	∅	■	■	■	•	•	•
Criterion 453 Series	■	•	∅	■	■	■	∅	•	S	■	∅	•	•
Drive 461 Series	■	•	•	•	■	■	■	•	■	■	∅	•	•
Jersey Series	•	•	•	•	■	■	•	•	■	■	∅	•	•
Leap 462 Series	■	■	∅	•	■	■	∅	■	∅	■	∅	•	■
Leap 464 Series WorkLounge	■	∅	•	•	■	■	•	•	∅	■	■	•	•
Max-Stacker 472 and Max-Stacker II 473 Series	•	•	•	•	•	•	•	•	∅	•	•	■	•
Move 490 Series	•	•	•	•	•	•	•	•	S	•	•	•	•
Parade! 470 Series	•	•	•	•	•	•	•	•	S	•	•	•	•
Player 475 Series	■	•	•	∅	•	•	•	•	∅	•	•	•	•
Protégé 433 Series	•	•	•	•	■	■	■	•	■	■	•	•	•
Rally 457 Series	•	•	•	•	■	■	■	•	■	■	•	•	•
Sensor 458 Series	•	•	■	•	■	■	S	•	■	■	∅	•	•
Siento 499 Series	•	■	∅	•	•	•	•	•	•	•	•	•	•
Snodgrass 474 Series	■	•	•	•	•	•	•	•	S	•	•	•	•
Think 465 Series	■	S	S	•	■	■	■	■	■	■	S	•	■

For individual quote information, or special requests not listed above, please submit an RFQ request form.

The form may be accessed at the following URL: <http://in2.steelcase.com/specialsrfq/>

*Maximum seat height is 33".

Minimum seat height is 14½" with 3" travel.

Legend

- = Not available
- = Available
- S = Standard offering
- ▶ See specification pages for details.

Resources



Style Number Index

260

Style Number Index

Style Number	Page	Description
421480N	246	Trilogy 421 Guest Chr
421482N	246	Trilogy 421 Guest Chr
421492N	246	Trilogy 421 Guest Chr
4331203	155	Protegé 433 Work Chr
4331213	155	Protegé 433 Work Chr
4331223	155	Protegé 433 Work Chr
4331403	155	Protegé 433 Work Chr
4331413	155	Protegé 433 Work Chr
4331423	155	Protegé 433 Work Chr
4333003	157	Protegé 433 Guest Chr
4333013	157	Protegé 433 Guest Chr
4333023	157	Protegé 433 Guest Chr
4335013	158	Protegé 433 Sled-Base Guest Chr
4335023	158	Protegé 433 Sled-Base Guest Chr
4535300	61	Criterion 453 MidBk Work Chr
4535300D	61	Criterion 453 MidBk Work Chr
4535301	59	Criterion 453 HiBk Work Chr
4535301D	59	Criterion 453 HiBk Work Chr
4535310	61	Criterion 453 MidBk Work Chr
4535310D	61	Criterion 453 MidBk Work Chr
4535310DH	61	Criterion 453 MidBk Work Chr
4535310DW	61	Criterion 453 MidBk Work Chr
4535310H	61	Criterion 453 MidBk Work Chr
4535310W	61	Criterion 453 MidBk Work Chr
4535311	59	Criterion 453 HiBk Work Chr
4535311D	59	Criterion 453 HiBk Work Chr
4535311DH	59	Criterion 453 HiBk Work Chr
4535311DW	59	Criterion 453 HiBk Work Chr
4535311H	59	Criterion 453 HiBk Work Chr
4535311W	59	Criterion 453 HiBk Work Chr
4535330	61	Criterion 453 MidBk Work Chr
4535330D	61	Criterion 453 MidBk Work Chr
4535330DH	61	Criterion 453 MidBk Work Chr
4535330DP	60	Criterion 453 MidBk Work Chr
4535330DW	61	Criterion 453 MidBk Work Chr
4535330H	61	Criterion 453 MidBk Work Chr
4535330P	60	Criterion 453 MidBk Work Chr
4535330W	61	Criterion 453 MidBk Work Chr
4535331	59	Criterion 453 HiBk Work Chr
4535331D	59	Criterion 453 HiBk Work Chr
4535331DH	59	Criterion 453 HiBk Work Chr
4535331DP	58	Criterion 453 HiBk Work Chr
4535331DW	59	Criterion 453 HiBk Work Chr
4535331H	59	Criterion 453 HiBk Work Chr
4535331P	58	Criterion 453 HiBk Work Chr
4535331W	59	Criterion 453 HiBk Work Chr
4537300	65	Criterion 453 MidBk Stool
4537300D	65	Criterion 453 MidBk Stool
4537301	63	Criterion 453 HiBk Stool
4537301D	63	Criterion 453 HiBk Stool
4537310	65	Criterion 453 MidBk Stool
4537310D	65	Criterion 453 MidBk Stool
4537310DH	65	Criterion 453 MidBk Stool
4537310DW	65	Criterion 453 MidBk Stool
4537310H	65	Criterion 453 MidBk Stool

Style Number	Page	Description
4537310W	65	Criterion 453 MidBk Stool
4537311	63	Criterion 453 HiBk Stool
4537311D	63	Criterion 453 HiBk Stool
4537311DH	63	Criterion 453 HiBk Stool
4537311DW	63	Criterion 453 HiBk Stool
4537311H	63	Criterion 453 HiBk Stool
4537311W	63	Criterion 453 HiBk Stool
4537330	65	Criterion 453 MidBk Stool
4537330D	65	Criterion 453 MidBk Stool
4537330DH	65	Criterion 453 MidBk Stool
4537330DP	64	Criterion 453 MidBk Stool
4537330DW	65	Criterion 453 MidBk Stool
4537330H	65	Criterion 453 MidBk Stool
4537330P	64	Criterion 453 MidBk Stool
4537330W	65	Criterion 453 MidBk Stool
4537331	63	Criterion 453 HiBk Stool
4537331D	63	Criterion 453 HiBk Stool
4537331DH	63	Criterion 453 HiBk Stool
4537331DP	62	Criterion 453 HiBk Stool
4537331DW	63	Criterion 453 HiBk Stool
4537331H	63	Criterion 453 HiBk Stool
4537331P	62	Criterion 453 HiBk Stool
4537331W	63	Criterion 453 HiBk Stool
4539301B	67	Criterion Plus 453 HiBk Work Chair
4539311B	67	Criterion Plus 453 HiBk Work Chair
4539311BH	67	Criterion Plus 453 HiBk Work Chair
4539311BW	67	Criterion Plus 453 HiBk Work Chair
4539331B	67	Criterion Plus 453 HiBk Work Chair
4539331BH	67	Criterion Plus 453 HiBk Work Chair
4539331BW	67	Criterion Plus 453 HiBk Work Chair
4571203	143	Rally 457 Work Chr
4571204	143	Rally 457 Work Chr
4571223	143	Rally 457 Work Chr
4571224	143	Rally 457 Work Chr
4571403	143	Rally 457 Work Chr
4571404	143	Rally 457 Work Chr
4571423	143	Rally 457 Work Chr
4571424	143	Rally 457 Work Chr
4573003	145	Rally 457 MidBk Guest Chr
4573023	145	Rally 457 MidBk Guest Chr
4575023	145	Rally 457 MidBk Guest Chr
4581203	135	Sensor 458 Sz II MidBk Work Chr
4581204	133	Sensor 458 Sz II HiBk Work Chr
4581206	131	Sensor 458 Sz II Adj-Bk Work Chr
4581223	135	Sensor 458 Sz II MidBk Work Chr
4581224	133	Sensor 458 Sz II HiBk Work Chr
4581226	130	Sensor 458 Sz II Adj-Bk Work Chr
4581227	129	Sensor 458 Sz II Adj HiBk Work Chr
4581233W	135	Sensor 458 Sz II MidBk Work Chr
4581234W	133	Sensor 458 Sz II HiBk Work Chr
4581236W	130	Sensor 458 Sz II Adj-Bk Work Chr
4581237W	129	Sensor 458 Sz II Adj HiBk Work Chr
4581403	135	Sensor 458 Sz II MidBk Work Chr
4581404	133	Sensor 458 Sz II HiBk Work Chr
4581406	131	Sensor 458 Sz II Adj-Bk Work Chr

Style Number	Page	Description	Style Number	Page	Description
4581423	135	Sensor 458 Sz II MidBk Work Chr	46513111	79	Think 465 Work Chr
4581424	133	Sensor 458 Sz II HiBk Work Chr	46520000	91	Think 465 Work Chr
4581426	130	Sensor 458 Sz II Adj-Bk Work Chr	46520001	91	Think 465 Work Chr
4581427	129	Sensor 458 Sz II Adj HiBk Work Chr	46520010	91	Think 465 Work Chr
4581433W	135	Sensor 458 Sz II MidBk Work Chr	46520011	91	Think 465 Work Chr
4581434W	133	Sensor 458 Sz II HiBk Work Chr	46520100	83	Think 465 Work Chr
4581436W	130	Sensor 458 Sz II Adj-Bk Work Chr	46520101	83	Think 465 Work Chr
4581437W	129	Sensor 458 Sz II Adj HiBk Work Chr	46520110	83	Think 465 Work Chr
4585023	136	Sensor 458 Sz II MidBk Sled Guest Chr	46520111	83	Think 465 Work Chr
4585093	136	Sensor 458 Sz II MidBk Sled Guest Chr	46521000	93	Think 465 Work Chr
4611101	103	Drive 461 Work Chr	46521001	93	Think 465 Work Chr
4611111	103	Drive 461 Work Chr	46521010	93	Think 465 Work Chr
4611301	103	Drive 461 Work Chr	46521011	93	Think 465 Work Chr
4611311	103	Drive 461 Work Chr	46521100	85	Think 465 Work Chr
4611401	103	Drive 461 Work Chr	46521101	85	Think 465 Work Chr
4611411	103	Drive 461 Work Chr	46521110	85	Think 465 Work Chr
46216179	25	Leap 462 Work Chair	46521111	85	Think 465 Work Chr
46216189	27	Leap 462 Work Chair	46522000	89	Think 465 Work Chr
46267179	29	Leap 462 Work Chair	46522001	89	Think 465 Work Chr
46267189	31	Leap 462 Work Chair	46522010	89	Think 465 Work Chr
463480	180	Ally 463 Sled-Base Multi-Purp Chr	46522011	89	Think 465 Work Chr
463482	180	Ally 463 Sled-Base Multi-Purp Chr	46522100	81	Think 465 Work Chr
464LOUNGE	38	Leap 464 WorkLounge	46522101	81	Think 465 Work Chr
464OTTOMAN	41	Leap 464 Ottoman	46522110	81	Think 465 Work Chr
46510000	90	Think 465 Work Chr	46522111	81	Think 465 Work Chr
46510001	90	Think 465 Work Chr	46523000	87	Think 465 Work Chr
46510010	91	Think 465 Work Chr	46523001	87	Think 465 Work Chr
46510011	91	Think 465 Work Chr	46523010	87	Think 465 Work Chr
46510100	82	Think 465 Work Chr	46523011	87	Think 465 Work Chr
46510101	82	Think 465 Work Chr	46523100	79	Think 465 Work Chr
46510110	83	Think 465 Work Chr	46523101	79	Think 465 Work Chr
46510111	83	Think 465 Work Chr	46523110	79	Think 465 Work Chr
46511000	92	Think 465 Work Chr	46523111	79	Think 465 Work Chr
46511001	92	Think 465 Work Chr	465THINK	77	Think 465 Design Pkg Work Chr
46511010	93	Think 465 Work Chr	465THINKS	76	Think 465 Design Pkg Work Chr
46511011	93	Think 465 Work Chr	465THINKS4U	76	Think 465 Design Pkg Work Chr
46511100	84	Think 465 Work Chr	470412	222	Parade 470 Stackable Seating
46511101	84	Think 465 Work Chr	470412N	222	Parade 470 Stackable Seating
46511110	85	Think 465 Work Chr	470419	222	Parade 470 Stackable Seating
46511111	85	Think 465 Work Chr	470419N	222	Parade 470 Stackable Seating
46512000	88	Think 465 Work Chr	470D	223	Parade 470 Transport/Strg Dolly
46512001	88	Think 465 Work Chr	470G	223	Parade 470 Alignment Device
46512010	89	Think 465 Work Chr	472410	231	Max-Stkr 472 Stackable Seating
46512011	89	Think 465 Work Chr	472410BR	231	Max-Stkr 472 Stackable Seating
46512100	80	Think 465 Work Chr	472410N	231	Max-Stkr 472 Stackable Seating
46512101	80	Think 465 Work Chr	472410NBR	231	Max-Stkr 472 Stackable Seating
46512110	81	Think 465 Work Chr	472410NTL	231	Max-Stkr 472 Stackable Seating
46512111	81	Think 465 Work Chr	472410NTLB	231	Max-Stkr 472 Stackable Seating
46513000	86	Think 465 Work Chr	472410NTR	231	Max-Stkr 472 Stackable Seating
46513001	86	Think 465 Work Chr	472410NTRB	231	Max-Stkr 472 Stackable Seating
46513010	87	Think 465 Work Chr	472410TL	231	Max-Stkr 472 Stackable Seating
46513011	87	Think 465 Work Chr	472410TLB	231	Max-Stkr 472 Stackable Seating
46513100	78	Think 465 Work Chr	472410TR	231	Max-Stkr 472 Stackable Seating
46513101	78	Think 465 Work Chr	472410TRB	231	Max-Stkr 472 Stackable Seating
46513110	79	Think 465 Work Chr	472BR	232	Max-Stkr 472 Bkrack Assy

Style Number Index, continued

Style Number	Page	Description
472G	232	Max-Stkr 472 Alignment Device
472TAL	232	Max-Stkr 472 Tablet Arm Assy
472TAR	232	Max-Stkr 472 Tablet Arm Assy
473410	241	Max-Stkr II 473 Stackable Seating
473410B	241	Max-Stkr II 473 Stackable Seating
473410N	241	Max-Stkr II 473 Stackable Seating
473410NB	241	Max-Stkr II 473 Stackable Seating
473410NTL	241	Max-Stkr II 473 Stackable Seating
473410NTLB	241	Max-Stkr II 473 Stackable Seating
473410NTR	241	Max-Stkr II 473 Stackable Seating
473410NTRB	241	Max-Stkr II 473 Stackable Seating
473410TL	241	Max-Stkr II 473 Stackable Seating
473410TLB	241	Max-Stkr II 473 Stackable Seating
473410TR	241	Max-Stkr II 473 Stackable Seating
473410TRB	241	Max-Stkr II 473 Stackable Seating
473B	242	Max-Stkr II 473 Bkrack Assy
473D	233, 243	Max-Stkr Trans/Strg Dolly
473G	242	Max-Stkr II 473 Alignment Device
473TL	242	Max-Stkr II 473 Tablet Arm Assy
473TR	242	Max-Stkr II 473 Tablet Arm Assy
474410M	215	Snodgrass 474 Multi-Purp Chr
474419M	215	Snodgrass 474 Multi-Purp Chr
474419W	215	Snodgrass 474 Multi-Purp Chr
474420M	215	Snodgrass 474 Multi-Purp Chr
474427W	215	Snodgrass 474 Multi-Purp Chr
474429M	215	Snodgrass 474 Multi-Purp Chr
474429W	215	Snodgrass 474 Multi-Purp Chr
475410M	187	Player 475 Leg-Base Multi-Purp Chr
475410MB	187	Player 475 Leg-Base Multi-Purp Chr
475410MTL	189	Player 475 Leg-Base Multi-Purp Chr
475410MTLB	189	Player 475 Leg-Base Multi-Purp Chr
475410MTR	189	Player 475 Leg-Base Multi-Purp Chr
475410MTRB	189	Player 475 Leg-Base Multi-Purp Chr
475412M	187	Player 475 Leg-Base Multi-Purp Chr
475412MB	187	Player 475 Leg-Base Multi-Purp Chr
475412MC	187	Player 475 Leg-Base Multi-Purp Chr
475415M	187	Player 475 Leg-Base Multi-Purp Chr
475415MB	187	Player 475 Leg-Base Multi-Purp Chr
475415MC	187	Player 475 Leg-Base Multi-Purp Chr
475480M	191	Player 475 Sled-Base Multi-Purp Chr
475480MB	191	Player 475 Sled-Base Multi-Purp Chr
475480MTL	193	Player 475 Sled-Base Multi-Purp Chr
475480MTLB	193	Player 475 Sled-Base Multi-Purp Chr
475480MTR	193	Player 475 Sled-Base Multi-Purp Chr
475480MTRB	193	Player 475 Sled-Base Multi-Purp Chr
475482M	191	Player 475 Sled-Base Multi-Purp Chr
475482MB	191	Player 475 Sled-Base Multi-Purp Chr
475485M	191	Player 475 Sled-Base Multi-Purp Chr
475485MB	191	Player 475 Sled-Base Multi-Purp Chr
475710M	195	Player 475 Leg-Base Stool
475710MB	195	Player 475 Leg-Base Stool
475712M	195	Player 475 Leg-Base Stool
475712MB	195	Player 475 Leg-Base Stool
475715M	195	Player 475 Leg-Base Stool

Style Number	Page	Description
475715MB	195	Player 475 Leg-Base Stool
475A	196	Player 475 Alignment Device
475B	196	Player 475 Bookrack
475D	197	Player 475 Transport/Strg Dolly
475G	196	Player 475 Ganging Device
4871110	165	Cachet 487 Swivel-Base Multi-Purp Chr
4871210	165	Cachet 487 Swivel-Base Multi-Purp Chr
4871211	165	Cachet 487 Swivel-Base Multi-Purp Chr
4877110	169	Cachet 487 Stool
4877210	169	Cachet 487 Stool
4877211	169	Cachet 487 Stool
4878100	167	Cachet 487 Leg-Base Multi-Purp Chr
4878110	167	Cachet 487 Leg-Base Multi-Purp Chr
4878200	167	Cachet 487 Leg-Base Multi-Purp Chr
4878201	167	Cachet 487 Leg-Base Multi-Purp Chr
4878210	167	Cachet 487 Leg-Base Multi-Purp Chr
4878211	167	Cachet 487 Leg-Base Multi-Purp Chr
487BK	171	Cachet 487 Cushion Upholstery Pkg
487D	173	Cachet 487 Transport/Strg Dolly
487G	173	Cachet 487Ganging/Alignment Device
487ST	172	Cachet 487 Cushion Upholstery Pkg
487STBK	170	Cachet 487 Cushion Upholstery Pkg
490410	207	Move 490 Multi-Use Chr
490410C	207	Move 490 Multi-Use Chr
490410U	207	Move 490 Multi-Use Chr
490410UC	207	Move 490 Multi-Use Chr
490410V	204	Move 490 Value Pkg Multi-Use Chr
490410VC	204	Move 490 Value Pkg Multi-Use Chr
490412	207	Move 490 Multi-Use Chr
490412C	207	Move 490 Multi-Use Chr
490412U	207	Move 490 Multi-Use Chr
490412UC	207	Move 490 Multi-Use Chr
490412V	204	Move 490 Value Pkg Multi-Use Chr
490412VC	204	Move 490 Value Pkg Multi-Use Chr
499111	49	Siento Mid-Back Desk Chr
499112	49	Siento Mid-Back Desk Chr
499121	49	Siento Mid-Back Desk Chr
499122	49	Siento Mid-Back Desk Chr
499211	49	Siento High-Back Desk Chr
499212	49	Siento High-Back Desk Chr
499221	49	Siento High-Back Desk Chr
499222	49	Siento High-Back Desk Chr
499SIENTO	46	Siento Design Pkg High-Back Chr
JERSEYV	112	Jersey Series Value Work Chr
LEAPV2	22	Leap 462 Work Chair
PROTEGEV	152	Protegé 433 Value Work Chr
TS38301	113	Jersey Chair
TS38302	114	Jersey Chair
TS38303	119	Jersey Pullover
TS38304	115	Jersey Chair
TS38305	115	Jersey Chair
TS38306	116	Jersey Chair
TS38307	116	Jersey Chair
TS38308	117	Jersey Chair

Style Number	Page	Description
TS38309	117	Jersey Chair
TS38310	118	Jersey Chair
TS38311	118	Jersey Chair

Trademark List

® The following registered trademarks are used under license from Steelcase Development Corporation: Accelerate, Ally, Answer, Anthem, Arrondi, Avenir, Ballet, Bix, Brayton International Collection, Brayton Textile Collection, Breton, Canto, Chancellor, Collegium, Company, Context, Criterion, Crushed Can, Decorum, Designtex, Details, Drive, Elective Elements, Ellipse, Ember Chrome, Emerge, Etude, Exclamation Mark, Firstfile, Gentry, Ginkgo, Ginkgo Biloba, Hardware, Ideo, Internode, Jersey, Kart, Kick, LaCosta, Latour, Leap, Let's B, Lyra, Lytyn, Manhattan Product Configuration, Max-Stacker, Media Dock, Metro, Migrations, Miko, Montage, Oriana, Parade, Pathways, Perfect Match, Player, Power Pincher, Portal, Protégé, Raf System, Rally, Relevant, Sensor, Series 9000, Springboard, Steelcase, Steelcase Design Partnership, Steelcase Workplace Performance, Stow Davis, TeamWork, Technique, Texpress, Think, Treehouse, Trilogy, Turnstone, Vecta, Vectaflex, Werndl, and Wizard.

® The following is a registered trademark of Byrne Electrical, Rockford, MI: Interport.

® The following is a registered trademark of DuPont, Wilmington, DE: Corian.

® The following is a registered trademark of Genlyte Thomas Company, Louisville, KY: Lightolier.

® The following is a registered trademark of Leviton Manufacturing Company, Little Neck, NY: Decora.

® The following is a registered trademark of Microsoft Corporation, Redmond, WA: Microsoft.

® The following is a registered trademark of Panduit Corporation, Lockport, IL: Panduit.

® The following is a registered trademark of Trav (Press), Cuneo, Italy: Assisa.

® The following is a registered trademark of Virtual Ink, Boston, MA: mimioActive.

® The following registered trademarks are under license from Wilkhahn Furniture Products: Avera, Confair, Senzo, Versal, and Wilkhahn FS.

® The following is a registered trademark of Wilsonart International, Temple, TX: Chemsurf.

™ The following trademarks are used under license from Steelcase Development Corporation: 4 o'clock, à la carte, Active/Passive Shelf, Adia, Airtouch, Alcove, Alerion, Alexander Street Collection, Aliso, Allegro, Alongside, American Elect, American Tradition, Anson, Arbor, Archipelago, Archive Collection, Arriva, Ascot, Astor, Austin, Avalon, Bira, Bonn, Boomerang, Bradbury, Breadbox, Brio, Burton, Buxton, Cachet, Callahan, Camber, Canopy, Cappuccino, Catalina, CbP, Chester, Chorus, Chronos, Ciao, Clarendon, Classic Rectangular, Collaboration, Collins, Cologne, Colorbox, Common (Shelf), Commons, Community, Community based Planning CbP, Convene, Convey, Cortex, Cosima, Croix, Cubby, Cubis, Cushion, Customiz, Dataduct, Datum, Deck, Dedoes, Déjà, Detour, Detriana, DNA, Domain, Donovan, Dorchester, Downspout, Drop Top Hutch, Duo, Duospace, Eastlake, Eastridge, Eco, Ella, Elsa, Emmy, Encounter, Enea, EnSync, Ensemble, Entourage, Environmental Impact Collection, Equinox, Escapade, Et Al, E-Table, Exponents, Express12, Extreme Conditions, Fillmore, Flat Top, Fling, Flip Top, Footnote, Fortuna, Frontier, Fuji, Futu, Galilei, Galveston, Garland, Ginger, Glenwood, Go Wall, Greco, Greenbrier, Grip, Groove, Groupwork, Hannah, Hatch, Hatchback, Hatteras, Health Design, Hitch, Huddleboard, Impact, Incognito, Indy, InfoWizard, InterAct, IOS, I-Solve, Jacket, Jenny, Jetty, Juice, Kendo, Kiana, L'Attitude, Lazlo, Lean Too, Lemon, Lift-N-Slide, Live Back, Lotus, Lyric, M/O, Malibu, Manhatten, Mansfield, Martini, Masque, Mingle, Monterey, Montreal, Move, MyWizard, Nadia, Nickel, Nine, Norfolk, Ontrak, Onyx, Outlook, Paloma, Parliament, Parts Advantage, Pasio, Passarelle, Patriarch, Patterson, Payback, Peek, Pendio, Personal Border, Pier Top, Pipe, Pisa, Playback, Portal, Progeny, Radio, Rag Top, Rei, Reunion, Rhine, Rialto, Ricetta, Riser, Rizzi Arc, Rocco, RoomWizard, Rover, Runaround, Runner, Satellite, Scribe, Shadow, Shield, Shortbed, Skinny, Sidebar, Sidewalk, Siento, Sieste, Sine, Smoke, Snug, Softwork, Spinz, Sportswear, St. Clair, Stationkits, Stiletto, Stuttgart, Super Shelf, Surprise!, Switch, Template, Terrazzo, Tessare, Theorem, Topaz, Topo, Top Spin, Touchdown, Train, Trolley, T-Wall, Umbrella, Underline, Unison, Uno, Venetia, Walden, Warehouse, Whittier, Windsor, Wizard WebSigns, Your Profile, Your Power, and Your Preference.

™ The following is a trademark of Microsoft Corporation, Redmond, WA: Windows.

™ The following is a trademark of Rodman Industries, Inc., Oconomowoc, WI: ResinCore1.

™ The following is a trademark of Ultrafabrics, LLC, Elmsford, NY: Ultraleather.

™ The following trademarks are used under license from Wilkhahn Furniture: Cana, Linus, Logon, Picto, Range, Stitz, Thema, Timetable, and Tubis.