

Table of Contents

e ³ environmental ceramicsteel.....	2-4
e ³ Cleaning / Daily Care and Maintenance	4
Express 12 Quick Ship Program	5 ★

Premium Whiteboards and Tackboards

How to Specify Premium Whiteboards and Tackboards.....	6
Premium Whiteboards Overview	8-9
Senti.....CSTXXXX	10-11
Edge.....CEDXXXX	12-13
Access	CACXXXX..... 14-15
Denska	CDEXXXXX..... 16-17
Session	CSEXXXXX..... 18-19
FreeFlow.....	CFFXXXX..... 20-23
Echo Projection Screen	GECHOX..... 24
Pin-Mag.....	CPMXXXX..... 25
Huddleboard	KXXXX..... 26-29
Combo Boards.....	CXXXX..... 30-31
Patient Room Boards	HXXXX..... 32-33

Availability

Electronic price list updated with release 168.B (U.S.) and 140.B (Canada), dated September 15, 2008.

Contractor Series Whiteboards and Tackboards

How to Specify Contractor Series Whiteboards and Tackboards	35
110 Series	36-37
555 Series	38-39

Accessories.....	40
Important Application Information (Including Spline Joints)	41
Finishes and COM Information.....	42
Surface Materials.....	43
Surface Material Application Matrix.....	44-45
PPPW Bracket Application Guide	46-47
Screenprint Options.....	48

► For a list of all trademarks, refer to the last page of this specification guide.



For Canadian Pricing

Calculate in the following order to avoid rounding errors:

- Multiply the base price and each option by 1.05.
- Round each to the nearest dollar.
- Add base and options for total list price.

Resources

Style Number Index	50
--------------------------	----

The e³ environmental ceramicsteel Difference

Steelcase Premium White Boards incorporated the e³ environmental ceramicsteel surface, which is the first and only ecologically intelligent whiteboard surface to receive a MBDC Cradle to Cradle Gold certification. Cradle to Cradle certification evaluates products for environmentally safe and healthy materials; energy and water use during production, the ability to recycle and reuse materials, and social responsibility. PolyVision, a Steelcase company, has created its fourth generation of ceramicsteel writing surfaces, e³, which delivers the properties of its best selling writing surface, P³ ceramicsteel, and complies with the Cradle to Cradle certification criteria. Steelcase will continue to follow standards set forth by MBDC Cradle to Cradle certification to reaffirm our commitment to sustainability. For over five decades, millions of boards have been produced around the world using PolyVision P³ ceramicsteel. PolyVision used this cross section of consumers to gather the information that helped determine what the next generation of writing surfaces should provide. Our internationally renowned R&D team worked with experts in the field of ceramics and technology to create e³ environmental ceramicsteel surface – the new industry standard for superior quality.

The e³ environmental ceramicsteel Advantage

The ceramic finish consists of a specially formulated glass substance applied by machine. The e³ environmental ceramicsteel surface is fused to steel at a temperature of approximately 1500 degrees Fahrenheit for markerboards. It registers at a minimum of five (5) on the revised Mohs hardness scale.

Benefits of e³

- Ultra-smooth writing surface
- Improved erasability
- Greater color contrast
- Significantly less surface/light distortion
- Optimum eye comfort
- Enhanced visibility
- Reduced chalk pressure, greater adherence
- Increased chalk/surface contrast
- Accepts magnets

Environmental Features

- Enamel fused to cold-rolled enamelling-grade steel
- In all coatings, the total amount of heavy metals cadmium, mercury, hexavalent chromium, and lead is less than 0.1%
- All coatings are free of arsenic and antimony
- No Volatile Organic Compounds (VOCs)
- Steel core is made from minimum 30% post-consumer and post-industrial waste
- e³ environmental ceramicsteel surface is 99% recyclable



Chemical Resistant



Scratch Resistant



Bacteria Resistant



Fire Resistant



Graffiti Resistant



Stain Resistant

Material Description

e³ environmental ceramicsteel is produced by a controlled, continuous coil-coating process. The surface consists of a steel core of .013" and .019" thickness covered on both sides with thin enamel coatings. The ceramic finish is fused to the steel at a temperature of approximately 1500°F for markerboard and 1250°F for chalkboard.

Characteristic	e ³ environmental ceramicsteel Markerboard	e ³ environmental ceramicsteel Chalkboard
Writeability	Can be written on with any dry-erase, semi-permanent, water-soluble, permanent marker, pen, or crayon without damaging the surface.	Superior, low-gloss, matte finish readily accepts chalk providing a sharp, unbroken line with less pressure and maximum surface adherence.
Visibility	Contrast/waviness for markerboards (light and dark effects) shall be no greater than 15 when tested with BYK - Gardner Wave Scan 5+ measurement device showing visual acuity (contrast sensitivity) to the human eye at distances greater than 3 meters (10' - 0"). Resolution (visual acuity) shall be based on 3 lines per degree and be visibly maintained beyond the current standard of 3 meters.	Contrast/waviness for chalkboards (light and dark effects) shall be no less than 20 when tested with the contrast measurement test with 773-gram load on chalk. Resolution (visual acuity) shall be based on 3 lines per degree and be visibly maintained beyond the current standard of 3 meters.
Erasability	Dry-erase marker ink can be wiped off easily with a dry cloth or standard eraser. Crayon, semi-permanent, and permanent marker pen inks can be removed with a solvent based cleaner.	Erases easily with a dry cloth or standard chalk eraser, retains minimal residual chalk dust, and will not leave "ghost writing." Color change (dark/light) after chalk erasing is reduced 60% from traditional surfaces.
Cleanability (Washability)	All residues that remain after normal erasing can be removed by following the care and cleaning instructions on the www.polyvision.com/e3cleaning website.	WET Ghost measurements on chalkboard surfaces before and after wet cleaning shall not exceed a factor of 0.49. For further care and cleaning instructions, refer to the www.polyvision.com/e3cleaning website.
Wearability	Vitrified glass-hard ceramic surface fused to light-gauge enameling grade steel at approximately +1500°F. High resistance to impact damage, abrasion, scratching, and color fading. The e ³ environmental ceramicsteel surface registers a 6.5 on the revised Mohs hardness scale.	Vitrified glass-hard ceramic surface fused to light-gauge enameling grade steel at approximately +1250°F. High resistance to impact damage, abrasion, scratching, and color fading. The e ³ environmental ceramicsteel surface registers at a minimum of 5 on the revised Mohs hardness scale.
Magnet Capability	The e ³ environmental ceramicsteel surfaces are ideal for all magnets and magnetic impregnated materials and will not be scratched or damaged from the contact.	The e ³ environmental ceramicsteel surfaces are ideal for all magnets and magnetic impregnated materials and will not be scratched or damaged from the contact.
Flame Resistance	The e ³ surface is 100% non-combustible.	The e ³ surface is 100% non-combustible.

Product and Characteristic	Writeability	Erasability	Cleanability
e³ environmental ceramicsteel Low-Gloss Markerboard	Provides the same writing characteristics as High-Gloss.	Low-Gloss surfaces will not erase as thoroughly as High-Gloss surfaces. When this occurs, a water-dampened cloth will be required to erase the surface.	After normal erasing of Low-Gloss surfaces, solvents may be used to remove harder-to-erase dry marker inks and residue from other pens. Always clear water rinse after using any cleaning agent on the surface. Refer to www.polyvision.com/e3cleaning for further details.

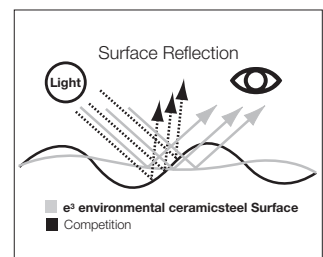
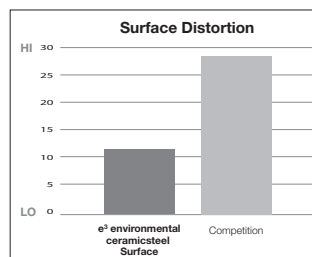
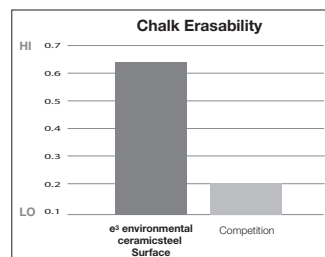
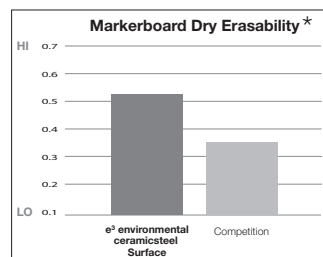

The ultra-smooth finish enables dry markers and chalk to glide easily across the e³ environmental ceramicsteel surface with minimal friction. The surface smoothness allows more dry-erase ink and chalk to be removed, improving erasability and eliminating "ghost writing."

Surface distortion (Orange Peel) has been reduced significantly in direct comparison with the competition's surface.

The e³ environmental ceramicsteel surface maximizes the performance of reflected light and reduces surface glare, resulting in improved visibility under a wide range of lighting conditions.

*All markerboard erasability tests were conducted using High-Gloss e³ environmental ceramicsteel surfaces.

For more information on e³ environmental ceramicsteel, visit: www.polyvision.com

e³ Cleaning / Daily Care and Maintenance

- Wipe board with a clean cloth moistened by a liquid markerboard cleaner or a solution of 50% water and 50% isopropyl alcohol
- Rinse with clear water
- Wipe dry with a clean cloth

If your board is used daily, the cleaning should be performed at least 2-3 times a week.

More thorough cleaning may be required if writing is left on the board for more than two days.

Markers

Use any high-quality dry erase marker.

CAUTION! Do not use Low Odor markers, or ghosting may occur. If Low Odor markers have been used, the surface can be completely cleaned by following the cleaning instructions above. Remember to discard eraser if used with Low Odor markers.

Removing Permanent Marker

Option 1:

- Write over the top of the permanent marker ink with a dry-erase marker
- Simply erase!

Option 2:

- Moisten a clean, dry cloth with isopropyl alcohol
- Wipe the board in a circular motion to loosen marker residue
- Rinse with clear water
- Dry the board with a clean cloth
- Repeat these steps as necessary

Installer's Instructions for Initial Cleaning at Time of Installation

NOTE: These initial cleaning instructions are shipped with every board.

- After installation of your board, remove the protective polyfilm from your writing surface by lifting from a corner and pulling the film away from the surface.
- For initial cleaning, wipe your board with a clean cloth moistened by a mild, alcohol-based cleaner.
- Rinse with clear water. This step is simple, but very important.
- Wipe dry with a clean cloth.

For online access to these instructions, visit: www.polyvision.com

Express 12 Quick Ship Program



- Applies to **Edge Series Premium Whiteboard** with clear anodized trim in the following sizes:
 - 36" x 24" (w x h)
 - 48" x 36" (w x h)
 - 48", 60", 72", 96" wide by 48" high
- Applies to **110 Contractor Series Whiteboard** in the following sizes:
 - 48", 72", 96", 144", wide by 48" high
- Up to 10 boards per order
- Ships standard with marker tray
- Ships 12 working days after receipt of order
- Look for "★" symbol beside available Edge sizes (page 13) and 110 sizes (page 36).

How to Specify Premium Whiteboards and Tackboards

Model Number Logic

Example: **CSEM054**

- Session 60" x 48" markerboard

C	SE	M	054
Premium Whiteboards and Tackboards	Frame Style (eg. Session)	M = Marker T = Tack	Size Code

How to Specify

- 1 Model Number
- 2 Trim
- 3 Surface
- 4 Options

Markerboard Specification Tool

Step One: Select Size			Step Two: Select Trim		Step Three: Select Surface		Step Four: Select Options		
Width x Height	Model Number	U. S. List Price	No Cost	Optional	No Cost	Optional	Optional (if required)	Optional (if required)	Optional (if required)
24" x 18"	CEDM0218	\$329	No Cost	4750	No Cost	7655	XSPL	PLMT	PPPW
36" x 24"	CEDM032	\$357	No Cost	4750	No Cost	7656	Spline Joint	Panel Mount	On and Off Module
48" x 36"	CEDM043	\$462	No Cost	4750	No Cost	7657			
48" x 48"	CEDM044	\$486	No Cost	4750	No Cost	7658			
60" x 48"	CEDM054	\$565	No Cost	4750	No Cost	7659			
72" x 48"	CEDM064	\$627	No Cost	4750	No Cost	7660			
96" x 48"	CEDM084	\$761	No Cost	4750	No Cost	7661			
120" x 48"	CEDM104	\$907	No Cost	4750	No Cost	7662			
144" x 48"	CEDM124	\$1,058	No Cost	4750	No Cost	7663			
192" x 48"	CEDM164	\$1,265	No Cost	4750	No Cost	7664			
			No Cost	4750	No Cost	7665			
			No Cost	4750	No Cost	7666			
			No Cost	4750	No Cost	7667			
			No Cost	4750	No Cost	7668			
			No Cost	4750	No Cost	7669			
			No Cost	4750	No Cost	7670			
			No Cost	4750	No Cost	7671			
			No Cost	4750	No Cost	7672			
			No Cost	4750	No Cost	7673			
			No Cost	4750	No Cost	7674			
			No Cost	4750	No Cost	7675			
			No Cost	4750	No Cost	7676			
			No Cost	4750	No Cost	7677			
			No Cost	4750	No Cost	7678			
			No Cost	4750	No Cost	7679			
			No Cost	4750	No Cost	7680			
			No Cost	4750	No Cost	7681			
			No Cost	4750	No Cost	7682			
			No Cost	4750	No Cost	7683			
			No Cost	4750	No Cost	7684			
			No Cost	4750	No Cost	7685			
			No Cost	4750	No Cost	7686			
			No Cost	4750	No Cost	7687			
			No Cost	4750	No Cost	7688			
			No Cost	4750	No Cost	7689			
			No Cost	4750	No Cost	7690			
			No Cost	4750	No Cost	7691			
			No Cost	4750	No Cost	7692			
			No Cost	4750	No Cost	7693			
			No Cost	4750	No Cost	7694			
			No Cost	4750	No Cost	7695			
			No Cost	4750	No Cost	7696			
			No Cost	4750	No Cost	7697			
			No Cost	4750	No Cost	7698			
			No Cost	4750	No Cost	7699			
			No Cost	4750	No Cost	7700			
			No Cost	4750	No Cost	7701			
			No Cost	4750	No Cost	7702			
			No Cost	4750	No Cost	7703			
			No Cost	4750	No Cost	7704			
			No Cost	4750	No Cost	7705			
			No Cost	4750	No Cost	7706			
			No Cost	4750	No Cost	7707			
			No Cost	4750	No Cost	7708			
			No Cost	4750	No Cost	7709			
			No Cost	4750	No Cost	7710			
			No Cost	4750	No Cost	7711			
			No Cost	4750	No Cost	7712			
			No Cost	4750	No Cost	7713			
			No Cost	4750	No Cost	7714			
			No Cost	4750	No Cost	7715			
			No Cost	4750	No Cost	7716			
			No Cost	4750	No Cost	7717			
			No Cost	4750	No Cost	7718			
			No Cost	4750	No Cost	7719			
			No Cost	4750	No Cost	7720			
			No Cost	4750	No Cost	7721			
			No Cost	4750	No Cost	7722			
			No Cost	4750	No Cost	7723			
			No Cost	4750	No Cost	7724			
			No Cost	4750	No Cost	7725			
			No Cost	4750	No Cost	7726			
			No Cost	4750	No Cost	7727			
			No Cost	4750	No Cost	7728			
			No Cost	4750	No Cost	7729			
			No Cost	4750	No Cost	7730			
			No Cost	4750	No Cost	7731			
			No Cost	4750	No Cost	7732			
			No Cost	4750	No Cost	7733			
			No Cost	4750	No Cost	7734			
			No Cost	4750	No Cost	7735			
			No Cost	4750	No Cost	7736			
			No Cost	4750	No Cost	7737			
			No Cost	4750	No Cost	7738			
			No Cost	4750	No Cost	7739			
			No Cost	4750	No Cost	7740			
			No Cost	4750	No Cost	7741			
			No Cost	4750	No Cost	7742			
			No Cost	4750	No Cost	7743			
			No Cost	4750	No Cost	7744			
			No Cost	4750	No Cost	7745			
			No Cost	4750	No Cost	7746			
			No Cost	4750	No Cost	7747			
			No Cost	4750	No Cost	7748			
			No Cost	4750	No Cost	7749			
			No Cost	4750	No Cost	7750			
			No Cost	4750	No Cost	7751			
			No Cost	4750	No Cost	7752			
			No Cost	4750	No Cost	7753			
			No Cost	4750	No Cost	7754			
			No Cost	4750	No Cost	7755			
			No Cost	4750	No Cost	7756			
			No Cost	4750	No Cost	7757			
			No Cost	4750	No Cost	7758			
			No Cost	4750	No Cost	7759			
			No Cost	4750	No Cost	7760			
			No Cost	4750	No Cost	7761			
			No Cost	4750	No Cost	7762			
			No Cost	4750	No Cost	7763			
			No Cost	4750	No Cost	7764			
			No Cost	4750	No Cost	7765			
			No Cost	4750	No Cost	7766			
			No Cost	4750	No Cost	7767			
			No Cost	4750	No Cost	7768			
			No Cost	4750	No Cost	7769			
			No Cost	4750	No Cost	7770			
			No Cost	4750	No Cost	7771			
			No Cost	4750	No Cost	7772			
			No Cost	4750	No Cost	7773			
			No Cost	4750	No Cost	7774			
			No Cost	4750	No Cost	7775			
			No Cost	4750	No Cost	7776			
			No Cost	4750	No Cost	7777			
			No Cost	4750	No Cost	7778			
			No Cost	4750	No Cost	7779			
			No Cost	4750	No Cost	7780			
			No Cost	4750	No Cost	7781			
			No Cost	4750	No Cost	7782			
			No Cost	4750	No Cost	7783			
			No Cost	4750	No Cost	7784			
			No Cost	4750	No Cost	7785			
			No Cost	4750	No Cost	7786			
			No Cost	4750	No Cost	7787			
			No Cost	4750	No Cost	7788			
			No Cost	4750	No Cost	7789			
			No Cost	4750	No Cost	7790			
			No Cost	4750	No Cost	7791			
			No Cost	4750	No Cost	7792			
			No Cost	4750	No Cost	7793			
			No Cost	4750	No Cost	7794			
			No Cost	4750	No Cost	7795			
			No Cost	4750	No Cost	7796			
			No Cost	4750	No Cost	7797			
			No Cost	4750	No Cost	7798			
			No Cost	4750	No Cost	7799			
			No Cost	4750	No Cost	7800			
			No Cost	4750	No Cost	7801			
			No Cost	4750	No Cost	7802			
			No Cost	4750	No Cost	7803			
			No Cost	4750	No Cost	7804			
			No Cost	4750	No Cost	7805			
			No Cost	4750	No Cost	7806			
			No Cost	4750	No Cost	7807			
			No Cost	4750	No Cost	7808			
			No Cost	4750	No Cost	7809			
			No Cost	4750	No Cost	7810			
			No Cost	4750	No Cost	7811			
			No Cost	4750	No Cost	7812			
			No Cost	4750	No Cost	7813			
			No Cost	4750	No Cost	7814			
			No Cost	4750	No Cost	7815			
			No Cost	4750	No Cost				

Premium Whiteboards Overview

Frame Options



Senti

















































Edge

Access

FreeFlow
Base α

Metal

w x h

24" x 18"	 • †	 •		
36" x 24"	 • †	 •		
48" x 36"	 • †	 • 	 	
48" x 48"	 • †	 • 	 	
60" x 48"	 •	 • 	 	
72" x 48"		 	 	
96" x 48"		 	 	
120" x 48"		  	  	
144" x 48"		 	 	
192" x 48"		 	 	

Complementary Products

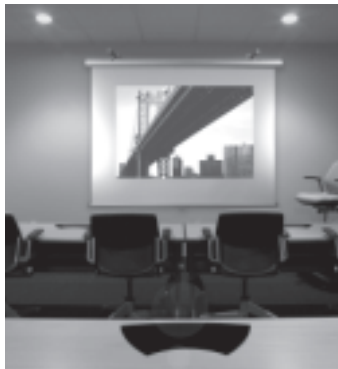

Echo Premium Projection Screen

- Streamlined European design
- Available sizes (w x h):
72" x 72", 96" x 96"
- Practical arms provide 9.8" (250mm) of screen depth adjustment to clear items wall-mounted beneath



Denska

Metal and Wood







Session

Wood



Legend

-  e³ environmental ceramicsteel markerboard
-  Tack or Combo Board option
-  Available either as a single markerboard or, if required, in two sections. Specify with spline joint.
-  FreeFlow base markerboard, with integral rail. Works with FreeFlow hang-on components.
- Panel mount option available
-  Magnetic mount option available

e³ environmental ceramicsteel Surface Benefits



Pin-Mag Premium Tackboard

- Unique perforated metal shell over tackable surface
- Available sizes (w x h):
24" x 18", 36" x 24", 48" x 36"
- Accepts both magnets and tacks

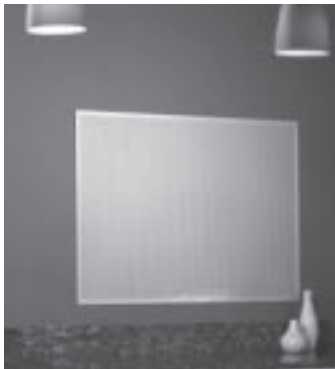

Design by Nygaard and Bodholt

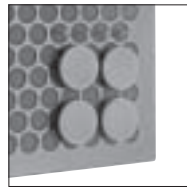

Senti Series



Standard includes:

- e³ environmental ceramicsteel writing surface
- Clear Anodized aluminum frame
- Matching aluminum marker tray
- Four corner mounting system with integral covers
- Pack of four dry-erase markers (black, blue, red, and green) and one eraser

Options:

- Screen printed pattern on e³ environmental ceramicsteel writing surface, not available on all sizes, specify screenprint pattern number. See page 48 for more information.
- Mounting options:
 - PLMT Panel or MGMT Magnetic: See page 41 for options and application information.
- For e³ care and maintenance instructions, see page 4.

Front View

Side View

Trim Cross-section

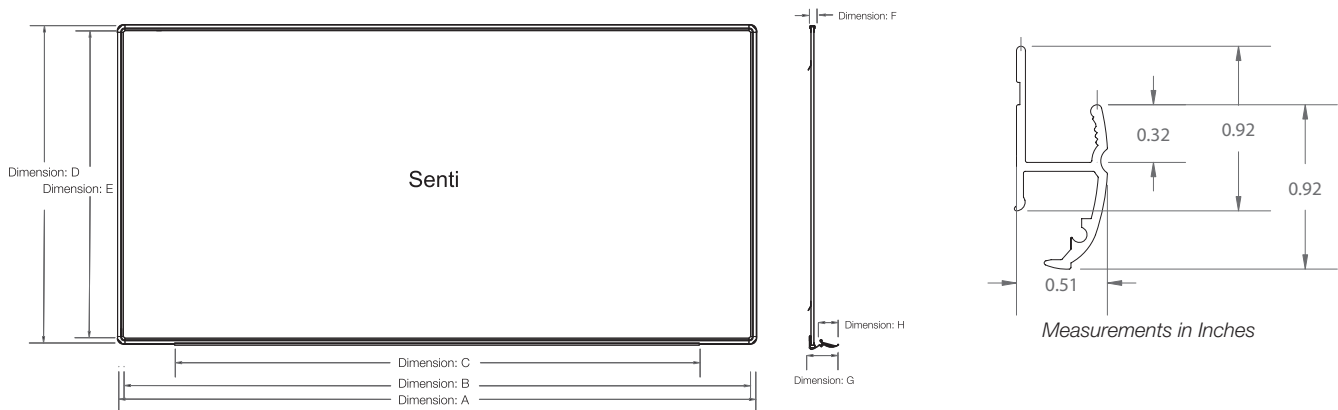

	Size Code	0218	032	043	044	054	064	084	104	124	164
	Marker	M	M	M	M	M	M				
A	Overall Width	24" 609mm	36" 914mm	48" 1219mm	48" 1219mm	60" 1524mm	72" 1829mm				
B	Surface Width	22.16" 563mm	34.16" 868mm	46.16" 1172mm	46.16" 1172mm	56.18" 1427mm	70.16" 1773mm				
C	Marker Tray Width	21.69" 551mm	33.69" 856mm	45.69" 1160mm	45.69" 1160mm	57.69" 1465mm	57.69" 1465mm				
D	Overall Height	18" 457mm	24" 610mm	36" 914mm	48" 1220mm	48" 1220mm	48" 1220mm				
E	Surface Height	16.16" 410mm	22.16" 563mm	34.16" 868mm	46.16" 1172mm	46.16" 1172mm	46.16" 1172mm				
F	Frame Depth	0.52" 13mm	0.52" 13mm	0.52" 13mm	0.52" 13mm	0.52" 13mm	0.52" 13mm				
G	Depth from Wall to Frame Face	0.55" 14mm	0.55" 14mm	0.55" 14mm	0.55" 14mm	0.55" 14mm	0.55" 14mm				
H	Marker Tray Depth	1.38" 35mm	1.38" 35mm	1.38" 35mm	1.38" 35mm	1.38" 35mm	1.38" 35mm				
	Weight LBS	6.4	12.7	25.5	34.0	42.5	51.0				
	Weight KGS	2.9	5.8	11.6	15.4	19.3	23.1				

Markerboard Specification Tool

① Step One: Select Size			+	② Step Two: Select Trim	+	③ Step Three: Select Surface		+	④ Step Four:	
Width x Height	Model Number	U. S. List Price				No Cost	Optional		Optional (if required)	Optional (if required)
24" x 18"	CSTM0218	\$242		No Cost		No Cost			Optional (if required)	Optional (if required)
36" x 24"	CSTM032	\$266		8043		7655	Screen Print		PLMT	MGMT
48" x 36"	CSTM043	\$341		Clear Anodized		High Gloss White	7656 Circular Dot Pattern 7657 2" Grid Pattern		Panel Mount	Magnetic Mount
48" x 48"	CSTM044	\$403		No Cost		No Cost			+\$72	+\$72
60" x 48"	CSTM054	\$430		No Cost		No Cost	+\$74		+\$72	+\$72
72" x 48"	CSTM064	\$488		No Cost		No Cost	+\$166		+\$72	+\$72
				No Cost		No Cost	+\$218		+\$72	+\$72
				No Cost		No Cost	+\$274		+\$72	
				No Cost		No Cost	+\$330			

Tackboard Specification Tool

Tackboard not available with this model.



For Canadian Pricing
 Multiply U.S. price by 1.05.
 ▶ See page 1 for details.

Edge Series



Standard includes:

- e³ environmental ceramicsteel writing surface on markerboards
- Fabric over 3/8" fiberboard on tackboards
- Clear Anodized aluminum frame
- Matching aluminum marker tray, markerboard only
- Metal cleat mounting system
- Pack of four dry-erase markers (black, blue, red, and green) and one eraser (markerboard only)

Options:

- Champagne powder-coat frame (up charge)
- Screen printed pattern on e³ environmental ceramicsteel writing surface, not available on all sizes, specify screenprint pattern number. IMPORTANT: Screenprint option **not** available with spline joint. See page 48 for more information.
- Spline joint, allows markerboard to be shipped in two (2) pieces, requires on site assembly. NOTE: Spline Joints are visible, see page 41 for more information; specify XSPL.
- For more information on COM fabrics, see page 42. COM fabrics must be tested.
- Mounting options:
 - PLMT Panel: See page 41 for options and application information.
 - PPPW On and Off Module Brackets: See page 46 for specific information.
- For e³ care and maintenance instructions, see page 4.

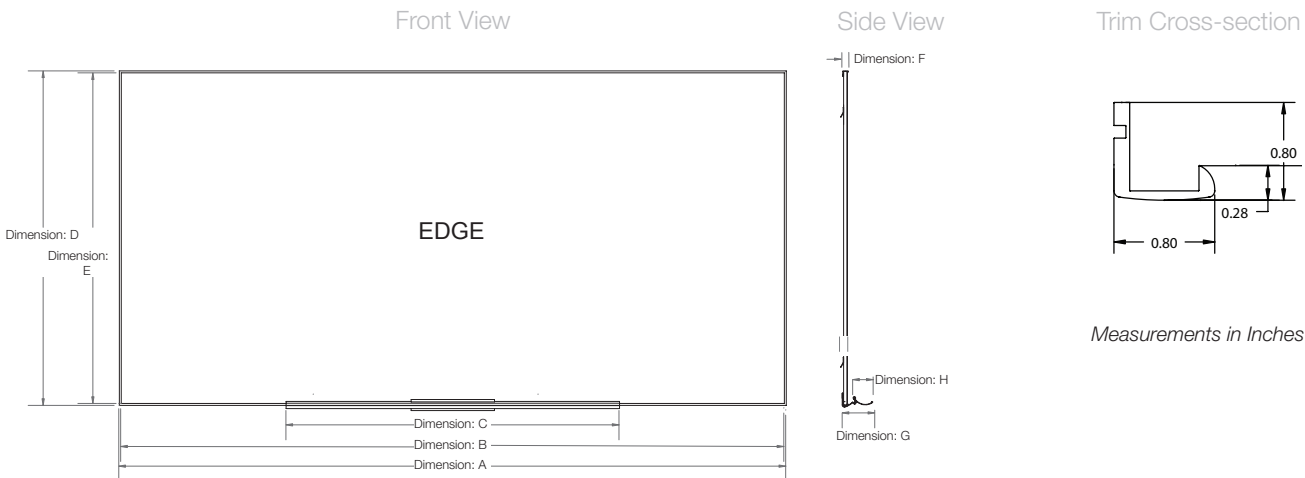

Measurements in Inches

	Size Code	0218	032	043	044	054	064	084	104	124	164
	Marker or Tackboard	M	M	M or T	M or T	M or T	M or T	M or T	M or T	M	M
A	Overall Width	24.25" 616mm	36.25" 921mm	48.25" 1226mm	48.25" 1226mm	60.25" 1530mm	72.25" 1835mm	96.25" 2445mm	120.25" 3054mm	144.25" 3664mm	192.25" 4883mm
B	Surface Width	23.7" 602mm	35.7" 907mm	47.7" 1212mm	47.7" 1212mm	59.7" 1516mm	71.7" 1821mm	95.7" 2431mm	119.7" 3040mm	143.7" 3650mm	191.7" 4869mm
C	Marker Tray Width	18" 457mm	24" 610mm	36" 914mm	36" 914mm	48" 1219mm	48" 1219mm	48" 1219mm	60" 1524mm	72" 1829mm	96" 2438mm
D	Overall Height	18.25" 463mm	24.25" 616mm	36.25" 921mm	48.25" 1225mm	48.25" 1225mm	48.25" 1225mm	48.25" 1225mm	48.25" 1225mm	48.25" 1225mm	48.25" 1225mm
E	Surface Height	17.85" 453mm	23.85" 606mm	35.85" 910mm	47.85" 1215mm	47.85" 1215mm	47.85" 1215mm	47.85" 1215mm	47.85" 1215mm	47.85" 1215mm	47.85" 1215mm
F	Frame Depth	0.72" 18mm	0.72" 18mm	0.72" 18mm	0.72" 18mm	0.72" 18mm	0.72" 18mm	0.72" 18mm	0.72" 18mm	0.72" 18mm	0.72" 18mm
G	Depth from Wall to Frame Face	1.11" 28mm	1.11" 28mm	1.11" 28mm	1.11" 28mm	1.11" 28mm	1.11" 28mm	1.11" 28mm	1.11" 28mm	1.11" 28mm	1.11" 28mm
H	Marker Tray Depth	3.53" 90mm	3.53" 90mm	3.53" 90mm	3.53" 90mm	3.53" 90mm	3.53" 90mm	3.53" 90mm	3.53" 90mm	3.53" 90mm	3.53" 90mm
	Weight (MB/TB) LBS	9.1	18.0	35.8/26.4	47.6/35.1	59.5/43.8	71.3/52.5	95.0/70.0	118.7/87.4	142.4	189.8
	Weight (MB/TB) KGS	4.1	8.2	16.2/12.0	21.6/16.0	27.0/19.9	32.4/23.8	43.1/31.7	53.8/39.6	64.6	86.1

NOTE: Tackboards do not have Marker Tray

Markerboard Specification Tool

Step One: Select Size			Step Two: Select Trim		Step Three: Select Surface		Step Four: Select Options		
Width x Height	Model Number	U. S. List Price	No Cost	Optional	No Cost	Optional	Optional (if required)	Optional (if required)	Optional (if required)
			8043	4750	7655	Screenprint	XSPL	PLMT	PPPW
			Clear Anodized	Champagne	High Gloss White	7656 Circular Dot Pattern 7657 2" Grid Pattern	Spline Joint	Panel Mount	On and Off Module
★ 24" x 18"	CEDM0218	\$329	No Cost	+\$47	No Cost			+\$72	
★ 36" x 24"	CEDM032	\$357	No Cost	+\$67	No Cost	+\$74		+\$72	
★ 48" x 36"	CEDM043	\$462	No Cost	+\$94	No Cost	+\$166		+\$72	
★ 48" x 48"	CEDM044	\$486	No Cost	+\$107	No Cost	+\$218		+\$72	+\$106
★ 60" x 48"	CEDM054	\$565	No Cost	+\$118	No Cost	+\$274		+\$72	+\$106
★ 72" x 48"	CEDM064	\$627	No Cost	+\$132	No Cost	+\$330			+\$106
★ 96" x 48"	CEDM084	\$761	No Cost	+\$161	No Cost	+\$440			+\$106
	120" x 48"	CEDM104	No Cost	+\$185	No Cost	+\$546			+\$106
	144" x 48"	CEDM124	No Cost	+\$215	No Cost				+\$106
	192" x 48"	CEDM164	No Cost	+\$264	No Cost				+\$106

Tackboard Specification Tool

Step One: Select Size			Step Two: Select Trim		Step Three: Select Surface				
Width x Height	Model Number	U. S. List Price	No Cost	Optional	Specify Fabric Color Number				See page 42 for yardage information
			8043	4750	Price Group 1	Price Group 2	Price Group 3	Price Group 4	COM
			Clear Anodized	Champagne	Abacus Bariolage	Brunswick Solara	Foxtrot Sumo Quasar	Rivergrass	
48" x 36"	CEDT043	\$462	No Cost	+\$94	No Cost	+\$38	+\$47	+\$68	+\$16
48" x 48"	CEDT044	\$486	No Cost	+\$107	No Cost	+\$38	+\$47	+\$68	+\$16
60" x 48"	CEDT054	\$565	No Cost	+\$118	No Cost	+\$45	+\$57	+\$86	+\$16
72" x 48"	CEDT064	\$627	No Cost	+\$132	No Cost	+\$50	+\$67	+\$104	+\$16
96" x 48"	CEDT084	\$761	No Cost	+\$161	No Cost	+\$52	+\$69	+\$113	+\$16
120" x 48"	CEDT104	\$907	No Cost	+\$185	No Cost	+\$57	+\$80	+\$136	+\$16

Combo Boards

Combo Boards (half marker, half tack) available. See page 30 for options.

★ Quick Ship

Quick Ship available for the following Edge boards:

- 36" x 24" (w x h) and 48" x 36" (w x h)
- 48", 60", 72", 96" wide by 48" high

See page 5 for details.



For Canadian Pricing
Multiply U.S. price by 1.05.
▶ See page 1 for details.

Access Series



Standard includes:

- e³ environmental ceramicsteel writing surface on markerboards
- Fabric over 3/8" fiberboard on tackboards
- Black powder-coated aluminum frame, with contrasting aluminum insert
- Aluminum marker tray matches insert, markerboard only
- Metal cleat mounting system
- Pack of four dry-erase markers (black, blue, red, and green) and one eraser (markerboard only)
- Satin Aluminum Trim

Options:

- Champagne Powder Coat insert, upcharge applies.
- Screen printed pattern on e³ environmental ceramicsteel writing surface, not available on all sizes, specify screenprint pattern number. IMPORTANT: Screenprint option **not** available with spline joint. See page 48 for more information.
- Spline joint, allows markerboard to be shipped in two (2) pieces, requires on-site assembly. NOTE: Spline joints are visible, see page 41 for more information, specify XSPL.
- For more information on COM fabrics, see page 42. COM fabrics must be tested.
- Mounting options:
 - PPPW On and Off Module Brackets: See page 46 for specific information.
- For e³ care and maintenance instructions, see page 4.

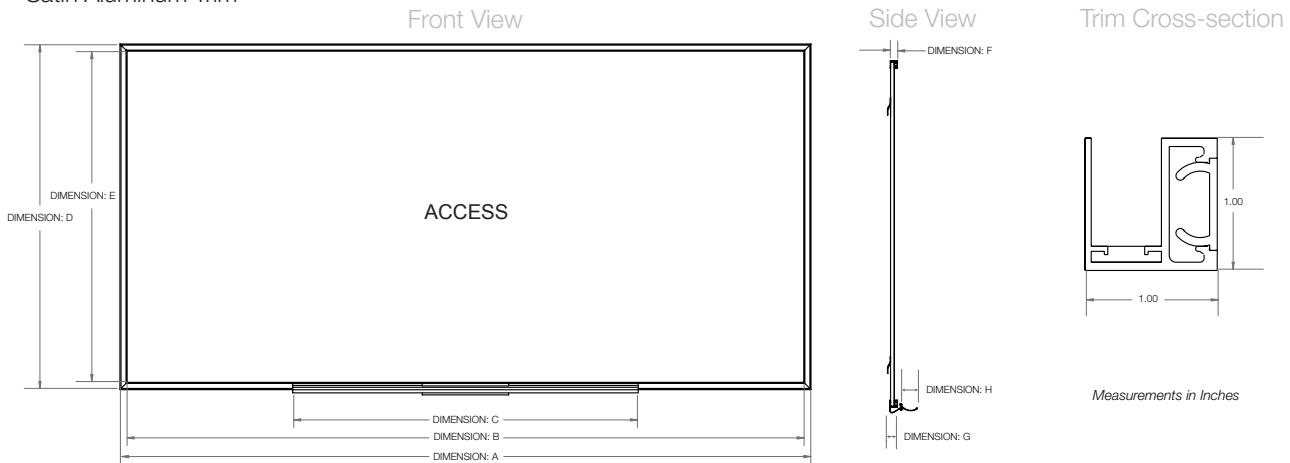

Measurements in Inches

	Size Code	0218	032	043	044	054	064	084	104	124	164
	Marker or Tackboard		M	M or T	M or T	M or T	M or T	M or T	M or T	M	M
A	Overall Width		36" 914mm	48" 1219mm	48" 1219mm	60" 1524mm	72" 1829mm	96" 2438mm	120" 3048mm	144" 3658mm	192" 4877mm
B	Surface Width		34" 864mm	46" 1168mm	46" 1168mm	58" 1473mm	70" 1778mm	94" 2388mm	118" 2997mm	142" 3607mm	190" 4826mm
C	Marker Tray Width		24" 610mm	36" 914mm	36" 914mm	48" 1219mm	48" 1219mm	48" 1219mm	60" 1524mm	72" 1829mm	96" 2438mm
D	Overall Height		24" 609mm	36" 914mm	48" 1219mm	48" 1219mm	48" 1219mm	48" 1219mm	48" 1219mm	48" 1219mm	48" 1219mm
E	Surface Height		22" 559mm	34" 864mm	46" 1168mm	46" 1168mm	46" 1168mm	46" 1168mm	46" 1168mm	46" 1168mm	46" 1168mm
F	Frame Depth		1" 25mm	1" 25mm	1" 25mm	1" 25mm	1" 25mm	1" 25mm	1" 25mm	1" 25mm	1" 25mm
G	Depth from Wall to Frame Face		2.15" 55mm	2.15" 55mm	2.15" 55mm	2.15" 55mm	2.15" 55mm	2.15" 55mm	2.15" 55mm	2.15" 55mm	2.15" 55mm
H	Marker Tray Depth		3.33" 85mm	3.33" 85mm	3.33" 85mm	3.33" 85mm	3.33" 85mm	3.33" 85mm	3.33" 85mm	3.33" 85mm	3.33" 85mm
	Weight (MB/TB) LBS		17.7	35.4/27.2	47.1/36.3	58.9/45.4	70.7/54.4	94.3/72.6	117.8/90.7	141.4	188.5
	Weight (MB/TB) KGS		8.0	16.0/12.4	21.4/16.5	26.7/20.6	32.1/24.7	42.8/33.0	53.5/41.2	64.1	85.5

NOTE: Tackboards do not have a marker tray.

Markerboard Specification Tool

① Step One: Select Size			② Step Two: Select Trim		③ Step Three: Select Surface		④ Step Four: Select Options	
Width x Height	Model Number	U. S. List Price	No Cost	Optional	No Cost	Optional	Optional	Optional (if required)
36" x 24"	CACM032	\$451	No Cost	8043	No Cost	7655	XSPL	
48" x 36"	CACM043	\$520	No Cost	4750	No Cost	Screenprint	PPPW	
48" x 48"	CACM044	\$584	No Cost	Clear Anodized	No Cost	High Gloss White	Spline Joint	On and Off Module
60" x 48"	CACM054	\$692	No Cost	Champagne	No Cost	7656 Circular Dot Pattern		
72" x 48"	CACM064	\$774	No Cost		No Cost	7657 2" Grid Pattern		
96" x 48"	CACM084	\$918	No Cost		No Cost			+\$106
120" x 48"	CACM104	\$1,122	No Cost		No Cost			+\$106
144" x 48"	CACM124	\$1,231	No Cost		No Cost			+\$106
192" x 48"	CACM164	\$1,525	No Cost		No Cost			+\$106

Tackboard Specification Tool

① Step One: Select Size			② Step Two: Select Trim		③ Step Three: Select Surface				
Width x Height	Model Number	U. S. List Price	Standard	Optional	Specify Fabric Color Number				See page 42 for yardage information
48" x 36"	CACT043	\$520	8043	4750	Price Group 1	Price Group 2	Price Group 3	Price Group 4	COM
48" x 48"	CACT044	\$584	Clear Anodized	Champagne	Abacus Bariolage	Brunswick Solara	Foxtrot Sumo Quasar	Rivergrass	
60" x 48"	CACT054	\$692	No Cost		No Cost	+\$38	+\$47	+\$68	+\$16
72" x 48"	CACT064	\$774	No Cost		No Cost	+\$38	+\$47	+\$68	+\$16
96" x 48"	CACT084	\$918	No Cost		No Cost	+\$45	+\$57	+\$86	+\$16
120" x 48"	CACT104	\$1,122	No Cost		No Cost	+\$50	+\$67	+\$104	+\$16
			No Cost		No Cost	+\$52	+\$69	+\$113	+\$16
			No Cost		No Cost	+\$58	+\$80	+\$136	+\$16

Combo Boards

Combo Boards (half marker, half tack) available.
See page 30 for options.



For Canadian Pricing
Multiply U.S. price by 1.05.
▶ See page 1 for details.

Denska Series



Standard includes:

- e³ environmental ceramicsteel writing surface
- Black powder-coated aluminum frame with wood insert
- Black powder-coated marker tray matches frame
- Metal cleat mounting system
- Pack of four dry-erase markers (black, blue, red, and green) and one eraser

Options:

- Screen printed pattern on e³ environmental ceramicsteel writing surface, not available on all sizes, specify screenprint pattern number. See page 48 for more information. **IMPORTANT:** Screenprint option not available with spline joint.
- Spline joint, allows markerboard to be shipped in two (2) pieces, requires on site assembly **NOTE:** Spline joints are visible, see page 41 for more information, specify XSPL.
- Mounting options:
 - PPPW On and Off Module Brackets: See page 46 for specific information.
- For e³ care and maintenance instructions, see page 4.

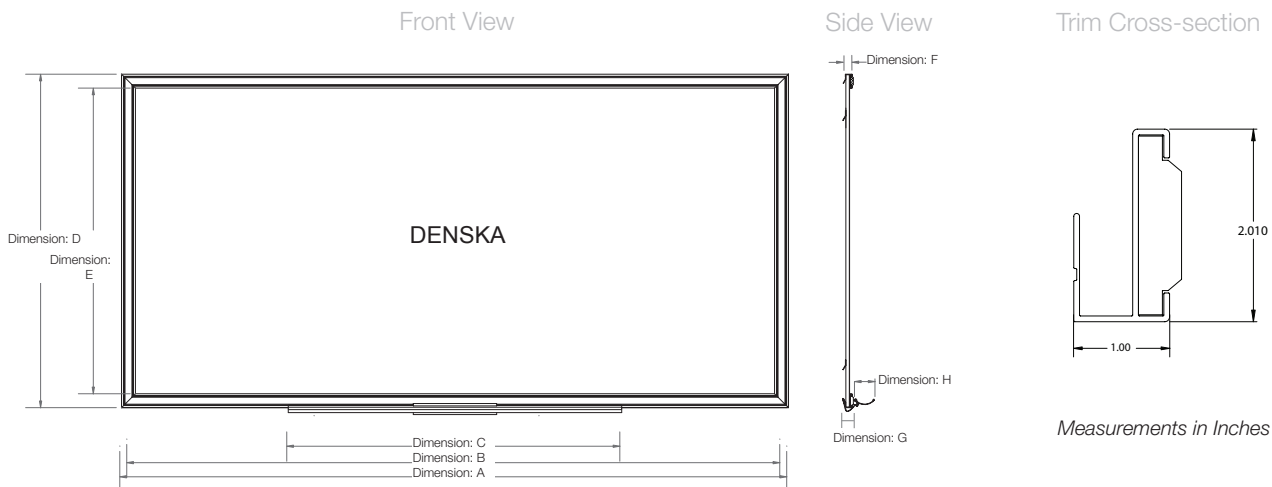

	Size Code	0218	032	043	044	054	064	084	104	124	164
	Marker or Tackboard		M	M	M	M	M	M	M	M	M
A	Overall Width		36.25" 921mm	48.25" 1226mm	48.25" 1226mm	60.25" 1530mm	72.25" 1835mm	96.25" 2445mm	120.25" 3054mm	144.25" 3664mm	192.25" 4883mm
B	Surface Width		32.3" 820mm	44.3" 1125mm	44.3" 1125mm	56.3" 1430mm	68.3" 1735mm	92.3" 2344mm	116.3" 2954mm	140.3" 3564mm	188.3" 4783mm
C	Marker Tray Width		24" 610mm	36" 914mm	36" 914mm	48" 1219mm	48" 1219mm	48" 1219mm	60" 1524mm	72" 1829mm	96" 2438mm
D	Overall Height		24.25" 616mm	36.25" 921mm	48.25" 1225mm	48.25" 1225mm	48.25" 1225mm	48.25" 1225mm	48.25" 1225mm	48.25" 1225mm	48.25" 1225mm
E	Surface Height		20.23" 514mm	32.23" 818mm	44.23" 1123mm	44.23" 1123mm	44.23" 1123mm	44.23" 1123mm	44.23" 1123mm	44.23" 1123mm	44.23" 1123mm
F	Frame Depth		1.46" 37mm	1.46" 37mm	1.46" 37mm	1.46" 37mm	1.46" 37mm	1.46" 37mm	1.46" 37mm	1.46" 37mm	1.46" 37mm
G	Depth from Wall to Frame Face		1.5" 38mm	1.5" 38mm	1.5" 38mm	1.5" 38mm	1.5" 38mm	1.5" 38mm	1.5" 38mm	1.5" 38mm	1.5" 38mm
H	Marker Tray Depth		3.03" 77mm	3.03" 77mm	3.03" 77mm	3.03" 77mm	3.03" 77mm	3.03" 77mm	3.03" 77mm	3.03" 77mm	3.03" 77mm
	Weight LBS		19.5	39.0	52.0	65.0	78.0	104.0	130.0	156.0	208.0
	Weight KGS		8.9	17.7	23.6	29.5	35.4	47.2	59.0	70.8	94.4

Markerboard Specification Tool

① Step One: Select Size			+	② Step Two: Select Trim	+	③ Step Three: Select Surface		+	④ Step Four: Select Options	
Width x Height	Model Number	U. S. List Price		No Cost		No Cost	Optional		Optional (if required)	Optional (if required)
				Select		7655	Screenprint		XSPL	PPPW
				3412 Natural Cherry on Cherry 3422 Medium Cherry on Cherry 3572 Amber on Maple 3592 Blonde on Maple 3712 Natural Walnut on Walnut 3772 Medium Mahogany on Walnut		High Gloss White	7656 Circular Dot Pattern 7657 2" Grid Pattern		Spline Joint	On and Off Module
36" x 24"	CDEM032	\$558		No Cost		No Cost	+\$74			
48" x 36"	CDEM043	\$707		No Cost		No Cost	+\$166			
48" x 48"	CDEM044	\$780		No Cost		No Cost	+\$218			+\$106
60" x 48"	CDEM054	\$860		No Cost		No Cost	+\$274			+\$106
72" x 48"	CDEM064	\$988		No Cost		No Cost	+\$330			+\$106
96" x 48"	CDEM084	\$1,137		No Cost		No Cost	+\$440			+\$106
120" x 48"	CDEM104	\$1,377		No Cost		No Cost	+\$546		+\$212	+\$106
144" x 48"	CDEM124	\$1,536		No Cost		No Cost			+\$212	+\$106
192" x 48"	CDEM164	\$1,956		No Cost		No Cost			+\$212	+\$106

Tackboard Specification Tool

Tackboard not available with this model.



For Canadian Pricing
Multiply U.S. price by 1.05.
▶ See page 1 for details.

Session Series



Standard includes:

- e³ environmental ceramicsteel writing surface on markerboards
- Fabric over 3/8" fiberboard on tackboards
- Solid wood frame
- Champagne powder-coated aluminum marker tray, markerboards only
- Metal cleat mounting system
- Pack of four dry-erase markers (black, blue, red, and green) and one eraser (markerboard only)

Options:

- Screen printed pattern on e³ environmental ceramicsteel writing surface, not available on all sizes, specify screenprint pattern number. See page 48 for more information.
- For more information on COM fabrics, see page 42. COM fabrics must be tested.
- Mounting options:
 - PPPW On and Off Module Brackets: See page 46 for specific information.
- For e³ care and maintenance instructions, see page 4.

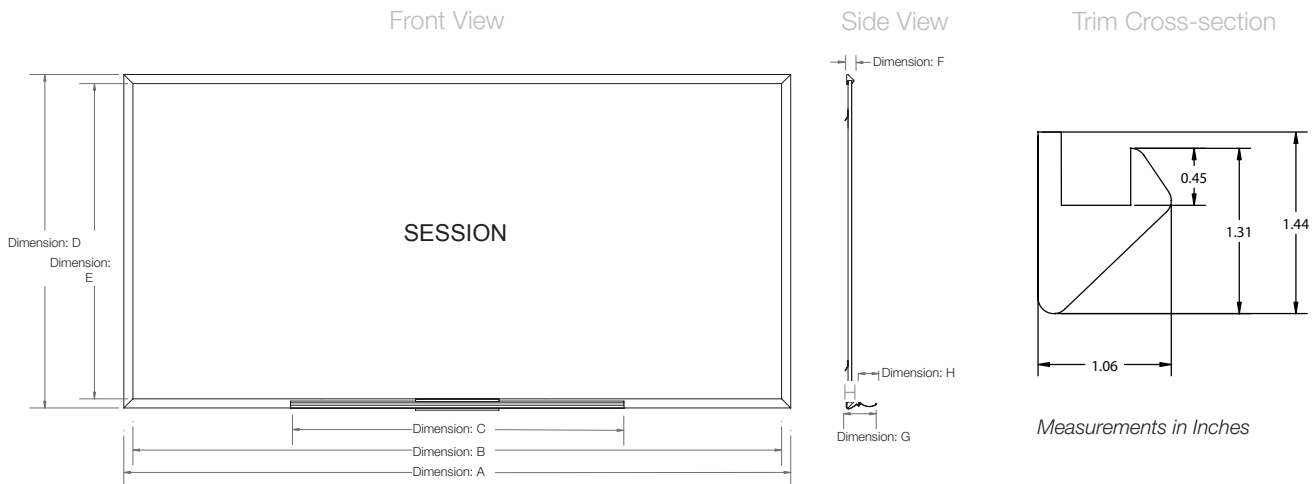

	Size Code	0218	032	043	044	054	064	084	104	124	164
	Marker or Tackboard			M or T	M or T	M or T	M or T	M or T	M or T		
A	Overall Width			48" 1219mm	48" 1219mm	60" 1524mm	72" 1829mm	96" 2438mm	120" 3048mm		
B	Surface Width			45" 1143mm	45" 1143mm	57" 1448mm	69" 1753mm	93" 2362mm	117" 2972mm		
C	Marker Tray Width			36" 914mm	36" 914mm	48" 1219mm	48" 1219mm	48" 1219mm	60" 1524mm		
D	Overall Height			36" 914mm	48" 1219mm	48" 1219mm	48" 1219mm	48" 1219mm	48" 1219mm		
E	Surface Height			33.50" 851mm	45.50" 1156mm	45.50" 1156mm	45.50" 1156mm	45.50" 1156mm	45.50" 1156mm		
F	Frame Depth			1.18" 30mm	1.18" 30mm	1.18" 30mm	1.18" 30mm	1.18" 30mm	1.18" 30mm		
G	Depth from Wall to Frame Face			1.47" 37mm	1.47" 37mm	1.47" 37mm	1.47" 37mm	1.47" 37mm	1.47" 37mm		
H	Marker Tray Depth			3.27" 83mm	3.27" 83mm	3.27" 83mm	3.27" 83mm	3.27" 83mm	3.27" 83mm		
	Weight (MB/TB) LBS			34.2/25.2	45.6/33.6	57.0/42.0	68.4/50.4	91.2/67.2	114.0/84.0		
	Weight (MB/TB) KGS			15.5/11.4	20.7/15.2	25.9/19.1	31.0/22.9	41.4/30.5	51.7/38.1		

NOTE: Tackboards do not have Marker Tray

Markerboard Specification Tool

① Step One: Select Size			+	② Step Two: Select Trim	+	③ Step Three: Select Surface		+	④ Step Four: Select Options
Width x Height	Model Number	U. S. List Price		No Cost		No Cost	Optional		Optional (if required)
				Select		7655	Screenprint		PPPW
				3412 Natural Cherry on Cherry 3422 Medium Cherry on Cherry 3572 Amber on Maple 3592 Blonde on Maple 3712 Natural Walnut on Walnut 3772 Medium Mahogany on Walnut		High Gloss White	7656 Circular Dot Pattern 7657 2" Grid Pattern		On and Off Module
48" x 36"	CSEM043	\$752		No Cost		No Cost	+\$166		+\$106
48" x 48"	CSEM044	\$848		No Cost		No Cost	+\$218		+\$106
60" x 48"	CSEM054	\$943		No Cost		No Cost	+\$274		+\$106
72" x 48"	CSEM064	\$1,058		No Cost		No Cost	+\$330		+\$106
96" x 48"	CSEM084	\$1,196		No Cost		No Cost	+\$440		+\$106
120" x 48"	CSEM104	\$1,380		No Cost		No Cost	+\$546		+\$106

Tackboard Specification Tool

① Step One: Select Size			+	② Step Two: Select Trim	+	③ Step Three: Select Surface				
Width x Height	Model Number	U. S. List Price		No Cost		Specify Fabric Color Number				See page 42 for yardage information
				Select		Price Group 1	Price Group 2	Price Group 3	Price Group 4	COM
				3412 Natural Cherry on Cherry 3422 Medium Cherry on Cherry 3572 Amber on Maple 3592 Blonde on Maple 3712 Natural Walnut on Walnut 3772 Medium Mahogany on Walnut		Abacus Bariolage	Brunswick Solara	Foxtrot Sumo Quasar	Rivergrass	
48" x 36"	CSET043	\$752		No Cost		No Cost	+\$38	+\$47	+\$68	+\$16
48" x 48"	CSET044	\$848		No Cost		No Cost	+\$38	+\$47	+\$68	+\$16
60" x 48"	CSET054	\$943		No Cost		No Cost	+\$45	+\$57	+\$86	+\$16
72" x 48"	CSET064	\$1,058		No Cost		No Cost	+\$50	+\$67	+\$104	+\$16
96" x 48"	CSET084	\$1,196		No Cost		No Cost	+\$52	+\$69	+\$113	+\$16
120" x 48"	CSET104	\$1,380		No Cost		No Cost	+\$58	+\$80	+\$136	+\$16

Combo Boards

Combo Boards (half marker, half tack) available.
See page 30 for options.



For Canadian Pricing
Multiply U.S. price by 1.05.
▶ See page 1 for details.

FreeFlow Series



Standard includes:

- e³ environmental ceramicsteel writing surface
- Clear Anodized aluminum frame with Champagne corners
- Clear Anodized aluminum marker tray
- Integral hanging rail to support FreeFlow components
- Metal cleat mounting system
- Pack of four dry-erase markers (black, blue, red, and green) and one eraser

Options:

- FreeFlow components also available. See page 22.
- Screen printed pattern on e³ environmental ceramicsteel writing surface, not available on all sizes, specify screenprint pattern number. See page 48 for more information.
- For e³ care and maintenance instructions, see page 4.

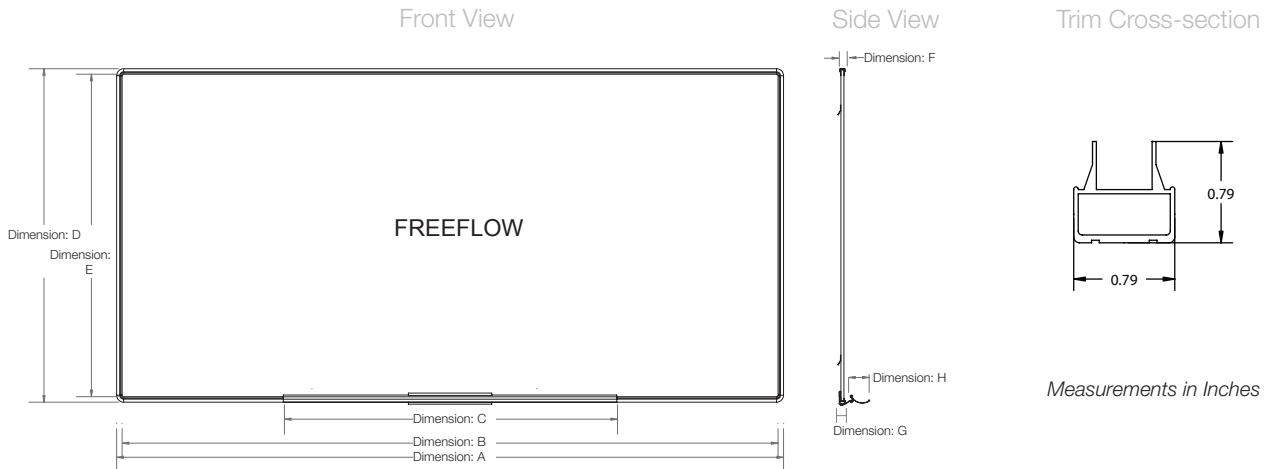

	Size Code	0218	032	043	044	054	064	084	104	124	164
	Marker or Tackboard						M	M	M	M	M
A	Overall Width						72" 1829mm	96" 2438mm	120" 3048mm	144" 3658mm	192" 4877mm
B	Surface Width						71.25" 1810mm	95.25" 2419mm	119.25" 3029mm	143.25" 3639mm	191.25" 4858mm
C	Marker Tray Width						48" 1219mm	48" 1219mm	60" 1524mm	72" 1829mm	96" 2438mm
D	Overall Height						48.25" 1226mm	48.25" 1226mm	48.25" 1226mm	48.25" 1226mm	48.25" 1226mm
E	Surface Height						47.50" 1207mm	47.50" 1207mm	47.50" 1207mm	47.50" 1207mm	47.50" 1207mm
F	Frame Depth						0.79" 20mm	0.79" 20mm	0.79" 20mm	0.79" 20mm	0.79" 20mm
G	Depth from Wall to Frame Face						1.04" 26mm	1.04" 26mm	1.04" 26mm	1.04" 26mm	1.04" 26mm
H	Marker Tray Depth						3.54" 90mm	3.54" 90mm	3.54" 90mm	3.54" 90mm	3.54" 90mm
	Weight LBS						54.0	78.0	96.0	117.0	156.0
	Weight KGS						24.5	35.4	43.6	53.1	70.8

Markerboard Specification Tool

① Step One: Select Size			② Step Two: Select Trim		③ Step Three: Select Surface			
Width x Height	Model Number	U. S. List Price			No Cost	Optional		
72" x 48"	CFFM064	\$733	+	No Cost	+	No Cost		
96" x 48"	CFFM084	\$886		8043		No Cost	Screenprint	
120" x 48"	CFFM104	\$1,040		Clear Anodized		7655	High Gloss White	7656 Circular Dot Pattern 7657 2" Grid Pattern
144" x 48"	CFFM124	\$1,203		No Cost		No Cost	+\$330	
192" x 48"	CFFM164	\$1,489		No Cost		No Cost	+\$440	
			No Cost	No Cost	+\$546			
			No Cost	No Cost				
			No Cost	No Cost				

Tackboard Specification Tool

Tackboard not available with this model.



For Canadian Pricing
 Multiply U.S. price by 1.05.
 ▶ See page 1 for details.

FreeFlow Series Components



IMPORTANT: Components require FreeFlow Base Board or FreeFlow Double Rail Track for mounting.

Standard includes:

- e³ environmental ceramicsteel writing surface on markerboards, double-sided
- Fabric over 3/8" fiberboard on tackboards, double-sided
- Clear Anodized aluminum frame with Champagne corners
- Book shelves are Clear Anodized aluminum, 12" deep (300mm)
- Projection surface is fabric membrane
- Flipchart base board is e³ environmental ceramicsteel writing surface. Projects 6" (300mm).
- Magnetic flipchart holder holds standard flipchart, attaches to any e³ environmental ceramicsteel writing surface or metal surface.
- For e³ care and maintenance instructions, see page 4.

FreeFlow Component Information

- FreeFlow components are rail-mounted and require either a FreeFlow Base Board or FreeFlow Double Rail Track for mounting.
- The combined width of all components must be 6" (150mm) less than the width of the FreeFlow Base Board or FreeFlow Double Rail Track on which they will be placed.
- FreeFlow Double Rail Track includes a top and bottom rail which allows for components to be mounted on either rail.
- FreeFlow Double Rail Track includes stops to prevent boards from accidentally sliding off the track.
- IMPORTANT: FreeFlow components DO NOT slide from the FreeFlow Base Board to/from Double Rail Track. These products are designed to work independently.
- FreeFlow projection screens extend above FreeFlow Base Board or Double Rail Track. Projection Screens may be angled forward to enhance viewing.
- FreeFlow Bottom Rail is an aluminum track designed to be used in conjunction with the Double Rail Track to facilitate sliding of components and eliminate wall damage. It is recommended that a Bottom Rail be specified whenever a Double Rail Track is specified.
- For more information on COM fabrics, see page 42. COM fabrics must be tested.

FreeFlow Components Specification Tool

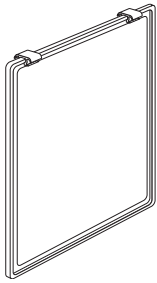

FreeFlow
Sliding Markerboard

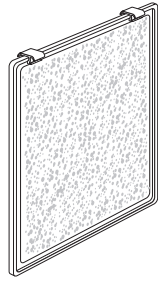

FreeFlow
Sliding Tackboard

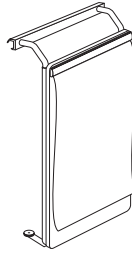

FreeFlow
Flipchart

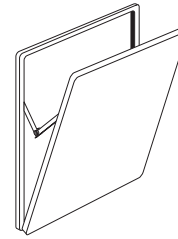

FreeFlow
Sliding Projection Screen

1

Step One: Select Component			
Width x Height	Weight	Model Number	U. S. List Price
35 3/4" x 45 3/4" Sliding Markerboard	24 lb	CFFSMB034	\$593
35 3/4" x 45 3/4" Sliding Tackboard	6 lb	CFFSTB034	\$593
30" x 43" Flipchart Holder	25 lb	CFFF	\$1,165
Magnetic Flipchart Holder	6 lb	CFFMFH30	\$173
49" x 49" Projection Screen	37 lb	CFFSCR49	\$1,702
56" x 56" Projection Screen	44 lb	CFFSCR56	\$1,848
64" x 64" Projection Screen	51 lb	CFFSCR64	\$2,366
8" Double Rail	2 lb	CFFT	\$287
8" Optional Bottom Rail (protects wall)	2 lb	CFFBT	\$160

2

Step Two:
No Cost
8043
+ Clear Anodized
No Cost
No Cost
No Cost
No Cost
No Cost
No Cost
No Cost
No Cost
No Cost
No Cost

3

Step Three: Select Surface					
No Cost	Specify Fabric Color Number				See page 42 for yardage information
Select	Price Group 1	Price Group 2	Price Group 3	Price Group 4	COM
7655 High Gloss White	Abacus Bariolage	Brunswick Solara	Foxtrot Sumo Quasar	Rivergrass	
No Cost					
	No Cost	+\$45	+\$57	+\$86	+\$16



For Canadian Pricing
Multiply U.S. price by 1.05.
▶ See page 1 for details.

Echo Projection Screen



Standard includes:

- Wall-mounted projection screen
- Wall-mount brackets project 9.8" (250mm) from wall to allow clearance for markerboards or other wall-mounted items. Screen depth is adjustable by means of set screws, Allen Key included.
- Clear Anodized aluminum trim
- White vinyl projection surface
- Screw mounting system

Projection Screen Specification Tool

Step One: Select Size		
Width x Height	Model Number	U. S. List Price
72" x 72"	CECHO6	\$1,105
96" x 96"	CECHO8	\$1,374



For Canadian Pricing
Multiply U.S. price by 1.05.
▶ See page 1 for details.

Pin-Mag Series

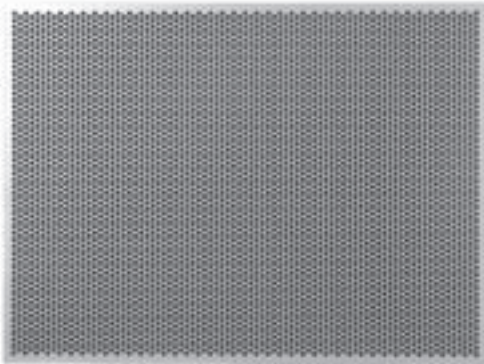

Design by: Nygaard & Bodholt

Standard includes:

- Unique perforated metal shell over tackable surface
- Works with tacks or magnets
- Powder-coated shell
- Fabric-covered tackable surface
- Screw mounting system; Pin-Mag may be hung vertically or horizontally
- Perforation diameter is nominally 1/2"
- Custom sizes not available

Options:

- For more information on COM fabrics, see page 42. COM fabrics must be tested.

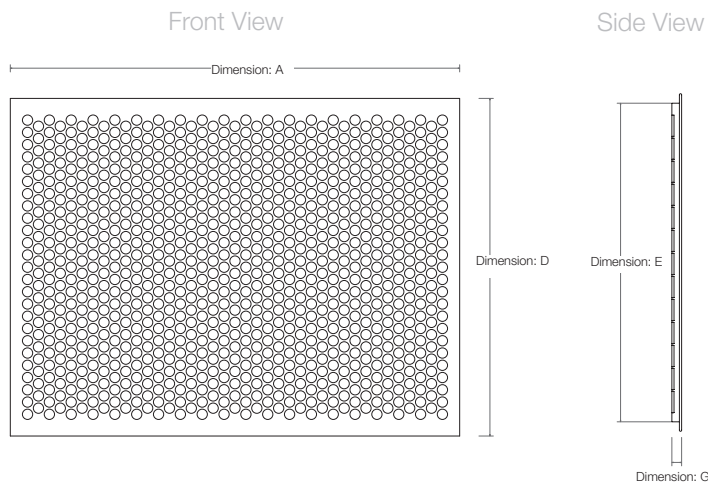

	Size Order Code	0218	032	043
A	Overall Width	23.6" 599mm	35.4" 899mm	47.2" 1198mm
B	Surface Width	22.1" 561mm	33.9" 861mm	45.7" 1160mm
C	Marker Tray Width			
D	Overall Height	17.7" 449mm	23.6" 599mm	35.4" 899mm
E	Surface Height	16.2" 411mm	22.1" 561mm	33.9" 861mm
F	Frame Depth			
G	Depth from Wall to Front Edge of Pen Tray	0.5" 12mm	0.5" 12mm	0.5" 12mm
H	Marker Tray Depth			
	Weight LBS	6	11	21
	Weight KGS	3	5	10

NOTE: Pin-Mag does not have Marker Tray

Tackboard Specification Tool

Step One: Select Size			Step Two: Select Trim		Step Three: Select Surface					
Width x Height	Model Number	U. S. List Price	No Cost		Specify Fabric Color Number				See page 42 for yardage information	
			Select		Price Group 1	Price Group 2	Price Group 3	Price Group 4	COM	
			+	4799 Platinum 0835 Black	+	Abacus Bariolage	Brunswick Solara	Foxtrot Sumo Quasar	Rivergrass	
24" x 18"	CPMT0218	\$417		No Cost		No Cost	+\$32	+\$39	+\$53	+\$16
36" x 24"	CPMT032	\$533		No Cost		No Cost	+\$32	+\$39	+\$53	+\$16
48" x 36"	CPMT043	\$811		No Cost		No Cost	+\$38	+\$47	+\$68	+\$16



For Canadian Pricing
Multiply U.S. price by 1.05.
▶ See page 1 for details.

Huddleboard Markerboards and Photo Boards



Standard includes:

- Markerboard surface, double-sided and available in two sizes
- Photo Board with 3M repositionable adhesive on one side, marker surface on reverse
- Boards come in packages of 5 unless specified
- Translucent plastic hanger hooks

NOTE: Huddleboards and Huddleboard Photo Boards have a one (1) year warranty

Optional Accessories:

- Ledge Grabbers, Flipchart Pegs and Markerboard Grips are sold separately and can be added to any Huddleboard Markerboard.
- Accessories are available in translucent plastic only.
- Accessories are sold in sets of 10 (5 pair), except Markerboard Grips which are sold in sets of 5.

NOTE: BHAB Huddleboard adaptor brackets are required for Pathways Post and Beam, and are available in the Steelcase Pathways Post and Beam Solutions Specification Guide.

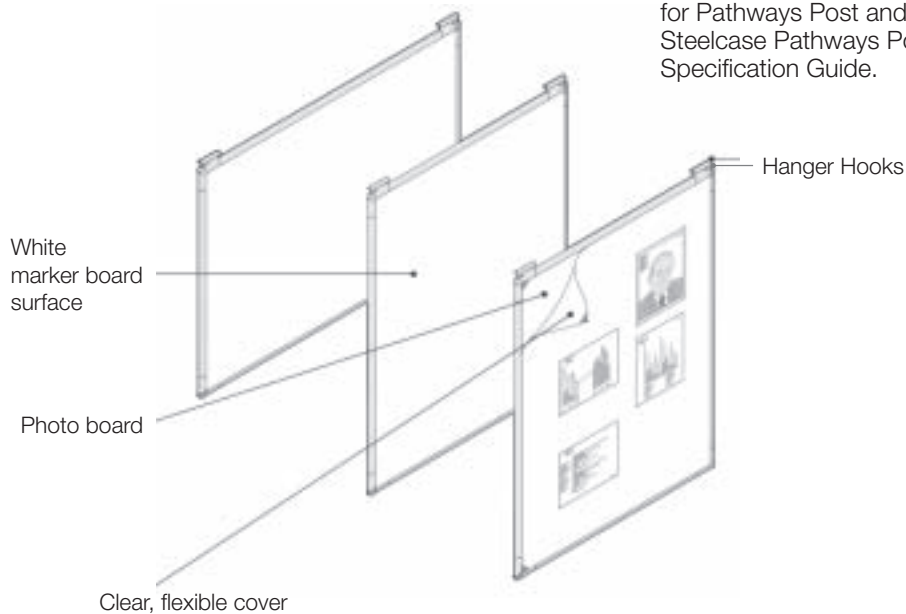

Dimensions	
Depth	3/4"
Width	23 1/3" or 32"
Height	32" to 42"
Weight	Less than 5 lbs.





Ledge Grabber



Flipchart Peg



Marker Grip



Mobile Easel with Landscape Orientation

Information:

- Huddleboard white marker surface accommodates dry erase markers. Double sided.
- Huddleboard Photo Album Board features a 3M repositionable adhesive used on Post-It products which provides an area for media to be displayed. Clear flexible cover protects media and provides a non-glare dry-erase writing surface which allows the user to write notes over media displayed without permanently altering them. Cover contains an easy-grip tab and magnetic top and bottom corner to secure the cover. Note: Photo Board is on one side only, reverse is white marker surface.
- Boards are not porcelain steel and do not accept magnets.
- Boards weigh less than 5 pounds each.
- Hanger Hooks are standard with all Huddleboards. Hooks can be removed and repositioned on any side of the board allowing board to be used in portrait or landscape format.
- Huddleboard and Huddleboard Photo Board are designed to be written on with dry erase ink. Boards can be cleaned using normal markerboard cleaner.

NOTE: Regular ink is not removable from Huddleboard surfaces.

- Ledge Grabbers have a non-slip rubber surface that anchors Huddleboards to panels, storage cabinets and other horizontal surfaces. Minimum surface depth of 1" (25.4mm) is required. Attaches to any size Huddleboard in landscape or portrait format.
- Flipchart Pegs attach to the frame of the Huddleboard and accept standard flipcharts.
- Marker Grip can be attached to the side of any Huddleboard to hold dry erase markers.

Mobile Easel

Standard Includes:

- Mobile Easel frame with storage capacity for 10 large boards, 4798 Sterling paint only.
- Storage tray for Mobile Easel 6696 Sterling plastic only.

Information:

- Mobile Easel has an adjustable board which can be set at 3 different heights to display boards, one for sitting and two for standing.

	Landscape to top of board	Portrait to top of board
Sitting Height	52" / 1321mm	63" / 1600mm
Standing Height 1	59" / 1500mm	71" / 1803mm
Standing Height 2	66" / 1676mm	78" / 1981mm

- Grips on the display board hold Huddleboards in place.
- Boards can be displayed portrait or landscape.
- Utility tray can support boards, dry erase markers and erasers.
- Side-access storage compartment provides an area to store and transport up to 10 large boards.
- Casters allow the board to easily be moved where needed.

Huddleboard Marker Boards and Photo Boards

Mounting Rails and Trays



Wall-Mounted Worktool Rail



Panel-Mounted Tray

Standard Includes:

- Worktool Rail is structural wall-mounted for hanging Huddleboards. Standard with choice of 8043 Clear Anodized aluminum or 8044 Black Anodized aluminum with 6653 Solar Black plastic end caps.
- Panel/Structural-mounted trays for leaning Huddleboards, standard 4798 Sterling Paint with 6696 Sterling plastic endcaps; includes structural wall (dry wall) mounting hardware.

Options:

- Panel-Mounted tray is available with optional panel-mounting hardware at no additional charge.
- Must be specified:
 - Answer/Kick/Privacy Wall specify with Answer hardware
 - Avenir, specify with Avenir hardware
 - Series 9000, specify with Series 9000 hardware

Information:

- Wall-Mounted Worktool Rail allows Huddleboards to be wall mounted and slid into position as required. Worktool Rail is 48" or 96" long.
- Panel/Structural-Mounted Tray can be mounted on panels or drywall. Panel/Structural-Mounted Tray accommodates all sizes of Huddleboards in portrait or landscape. There are 3 channels in the tray which accommodate Huddleboards or provide excellent storage for dry erase markers and erasers. Trays are available in 3 widths: 36", 48", or 72". Hardware is included to mount to drywall. Optional panel-mount hardware is available for Avenir, Answer (Kick and Privacy Wall), and Series 9000.

Huddleboard Components Specification Tool

1

Step One: Select Size			
Markerboards and Photo Album Boards	Dimensions	Model Number	U.S. List Price
Small Markerboard Package (5)	23" x 32" x .75"d	K5M2332	\$602
Small Board Package WITH Accessories: 1x Markerboard, 2x Ledge Grabbers and 1x Markerboard Grip	23" x 32" x .75"d	KSM2332	\$171
Large Combination Board Package - 4 Marker / 1 Photo boards	32" x 42" x .75"d	K4M1P3242	\$861
Large Markerboard Package (5)	32" x 42" x .75"d	K5M3242	\$652
Large Board Package with Accessories: 1x Markerboard, 2x Ledge Grabbers and 1x Markerboard Grip	32" x 42" x .75"d	KSM3242	\$216
Large Photo Board Package (5)	32" x 42" x .75"d	K5P3242	\$1,642
Ledge Grabber Package of 10	3.5" w x 3" d x 1" h	KLG	\$89
Flip Chart Peg Package of 10	1.25" w x 1.5" d x 2" h	KPEG	\$82
Markerboard Grip Package of 5	1.625" w x 1.25" d x 2" h	KMGRIP	\$67

2

Step Two: Select Trim
6672 Platinum White frame
6672 Platinum White frame
6672 Platinum White frame
6672 Platinum White frame
6672 Platinum White frame
Translucent Plastic
Translucent Plastic
Translucent Plastic

3

Step One: Select Size			
Easels	Width x Height	Model Number	
Mobile Easel	37" w x 29.25" d x 50-60" h	KME	\$980

Step Two: Select Trim
4798 Sterling Paint

Step One: Select Size			
Racks and Rails	Width x Height	Model Number	U.S. List Price
Panel/Structural Tray 36" w	36" w x 4.5" d	KPMT36	\$190
Panel/Structural Tray 48" w	48" w x 4.5" d	KPMT48	\$232
Panel/Structural Tray 72" w	72" w x 4.5" d	KPMT72	\$271
Worktool Rail 48" w	48" w x 2" d x 1.25" h	GCJWT48	\$386
Worktool Rail 96" w	96" w x 2" d x 1.25" h	GCJWT96	\$694

Step Two: Select Trim
4798 Sterling Paint
4798 Sterling Paint
4798 Sterling Paint
8043 Clear Anodized
8044 Black Anodized
8043 Clear Anodized
8044 Black Anodized

Step Three: Select
Optional if Required
Panel Mount
Specify System
Specify System
Specify System



For Canadian Pricing
 Multiply U.S. price by 1.05.
 ▶ See page 1 for details.

Combo Boards



Includes Marker Tray

Standard includes:

- Half marker, half fabric tackable surface divided by a $\frac{3}{4}$ " vertical aluminum extrusion
- e³ environmental ceramicsteel writing surface on markerboards
- Fabric over $\frac{3}{8}$ " fiberboard on tackboards
- Matching aluminum marker tray is centered on the board
- Vertical Aluminum Extrusion color will match marker tray finish.
- Available with Edge, Access or Session trims. For more information on trim profiles and marker tray, refer to main Edge, Access and Session pages.
- Metal cleat mounting system
- Pack of four dry-erase markers (black, blue, red, and green) and one eraser

Options:

- For more information on COM fabrics, see page 42. COM fabrics must be tested.
- Mounting options:
 - PPPW On and Off Module Brackets: See page 46 for specific information.
- Other configurations available.
- For e³ care and maintenance instructions, see page 4.

Combo Board Specification Tool

1

Step One: Select Size and Orientation

Markerboard on Right Panel		Markerboard on Left Panel	
Width x Height	Markerboard on Right Model Number	Markerboard on Left Model Number	U.S. List Price

Edge			
24" x 18"	CEDMR0218	CEDML0218	\$403
36" x 24"	CEDMR032	CEDML032	\$437
48" x 48"	CEDMR044	CEDML044	\$553
60" x 48"	CEDMR054	CEDML054	\$628
72" x 48"	CEDMR064	CEDML064	\$690
96" x 48"	CEDMR084	CEDML084	\$837
120" x 48"	CEDMR104	CEDML104	\$997
144" x 48"	CEDMR124	CEDML124	\$1,164

Access			
36" x 24"	CACMR032	CACML032	\$531
48" x 48"	CACMR044	CACML044	\$642
60" x 48"	CACMR054	CACML054	\$761
72" x 48"	CACMR064	CACML064	\$852
96" x 48"	CACMR084	CACML084	\$1,010
120" x 48"	CACMR104	CACML104	\$1,235
144" x 48"	CACMR124	CACML124	\$1,355

Session			
48" x 36"	CSEMR043	CSEML043	\$889
48" x 48"	CSEMR044	CSEML044	\$933
60" x 48"	CSEMR054	CSEML054	\$1,038
72" x 48"	CSEMR064	CSEML064	\$1,164
96" x 48"	CSEMR084	CSEML084	\$1,315
120" x 48"	CSEMR104	CSEML104	\$1,519

2

Step Two: Select Trim

No Cost	Optional
8043 Clear Anodized	4750 Champagne

No Cost	+\$47
No Cost	+\$67
No Cost	+\$107
No Cost	+\$118
No Cost	+\$132
No Cost	+\$161
No Cost	+\$185
No Cost	+\$215

No Cost	+\$67
No Cost	+\$107
No Cost	+\$118
No Cost	+\$132
No Cost	+\$161
No Cost	+\$185
No Cost	+\$215

3412 Natural Cherry on Cherry
3422 Medium Cherry on Cherry
3572 Amber on Maple
3592 Blonde on Maple
3712 Natural Walnut on Walnut
3772 Medium Mahogany on Walnut
No Cost
No Cost
No Cost
No Cost
No Cost
No Cost

3

Step Three: Select Surface

Specify Fabric Color Number				See page 42 for yardage information	Optional (if required)
Price Group 1	Price Group 2	Price Group 3	Price Group 4	COM	PPPW
Abacus Bariolage	Brunswick Solara	Foxtrot Sumo Quasar	Rivergrass		On and Off Module

No Charge	+\$9	+\$13	+\$17	+\$16	
No Charge	+\$9	+\$13	+\$17	+\$16	
No Charge	+\$19	+\$24	+\$35	+\$16	+\$106
No Charge	+\$23	+\$27	+\$43	+\$16	+\$106
No Charge	+\$38	+\$47	+\$68	+\$16	+\$106
No Charge	+\$38	+\$47	+\$68	+\$16	+\$106
No Charge	+\$45	+\$57	+\$86	+\$16	+\$106
No Charge	+\$50	+\$67	+\$104	+\$16	+\$106

No Charge	+\$9	+\$13	+\$17	+\$16	
No Charge	+\$19	+\$24	+\$35	+\$16	
No Charge	+\$23	+\$27	+\$43	+\$16	+\$106
No Charge	+\$38	+\$47	+\$68	+\$16	+\$106
No Charge	+\$38	+\$47	+\$68	+\$16	+\$106
No Charge	+\$45	+\$57	+\$86	+\$16	+\$106
No Charge	+\$50	+\$67	+\$104	+\$16	+\$106

No Charge	+\$19	+\$24	+\$35	+\$16	
No Charge	+\$19	+\$24	+\$35	+\$16	+\$106
No Charge	+\$23	+\$27	+\$43	+\$16	+\$106
No Charge	+\$38	+\$47	+\$68	+\$16	+\$106
No Charge	+\$45	+\$57	+\$86	+\$16	+\$106
No Charge	+\$50	+\$67	+\$104	+\$16	+\$106



For Canadian Pricing
 Multiply U.S. price by 1.05.
 ▶ See page 1 for details.

Patient Room Boards

Graphic Option A (CEDH01827):

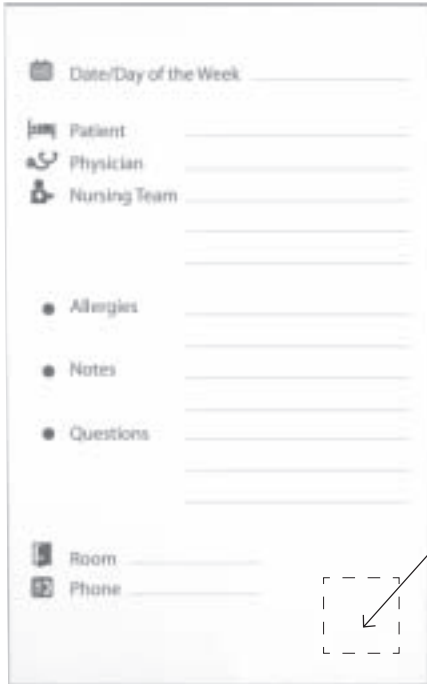

Optional Custom Logo (\$) Print Area Up to 3.75"

Graphic Option B (CEDH21827):

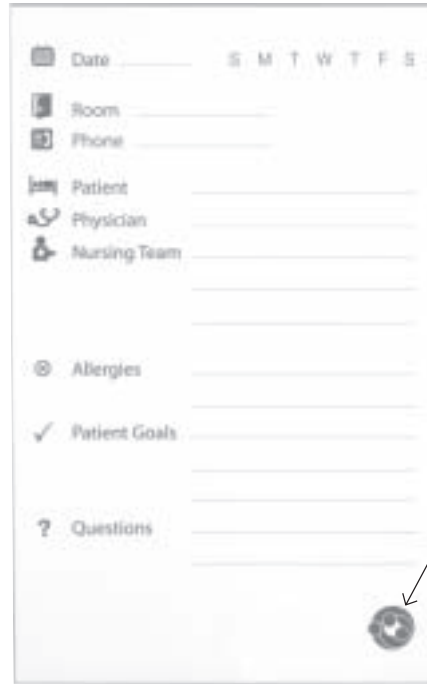

Nurture logo is standard.

Must specify "No Logo".

Standard includes:

- Standard screenprint graphic available in 2 standard ink colors permanently fused to e³ environmental ceramicsteel writing surface
- Half marker, half fabric tackable surface divided by a 3/4" vertical aluminum extrusion.
- Icons make information easy to understand without multi-lingual text
- Available as Markerboard or Combo Board
- Fabric over 3/8" fiberboard on tackboards
- Edge trim is standard. For more information on trim profile, see page 12.
- Matching aluminum marker tray
- Metal cleat mounting system with anti-dislodgement system
- Pack of four dry-erase markers (black, blue, red, and green) and one eraser
- Markerboard weighs approximately 25 lbs.
- Combo Board weighs approximately 40 lbs.

Options:





- For more information on COM fabrics, see page 42. COM fabrics must be tested.
- Custom sizes, configurations, graphics, and logos in single or multi-color available. See page 48 for additional information about custom screenprint.
- For e³ care and maintenance instructions, see page 4.

Patient Room Board Specification Tool

Markerboard Only:

① Step One: Select Size				② Step Two: Trim		③ Step Three: Select Ink	
Width x Height	Weight	Model Number	U.S. List Price	No Cost	Optional	No Cost	No Cost
17.75" x 27.75"	25 lb	CEDH01827 (Graphic A)	\$397	8043	4750, 4990	Ink 2	Ink 3
17.75" x 27.75"	25 lb	CEDH21827 (Graphic B)	\$397	Clear Anodized	Champagne	Taupe	Gray
				No Cost	+\$67	No Cost	No Cost
				No Cost	+\$67	No Cost	No Cost

Combo Board:

① Step One: Select Size and Orientation				② Step Two: Select Trim		③ Step Three: Select Ink		④ Step Four: Select Surface					
 Markerboard and Graphic A on Right Panel CEDHCR03627  Markerboard and Graphic A on Left Panel CEDHCL03627				No Cost	Optional	No Cost	No Cost	Specify Fabric Color Number					See page 42 for yardage information
Refer to opposite page for Graphics A and B details.								Price Group 1	Price Group 2	Price Group 3	Price Group 4	COM	
 Markerboard and Graphic B on Right Panel CEDHCR23627  Markerboard and Graphic B on Left Panel CEDHCL23627				8043 Clear Anodized	4750 Champagne	Ink 2 Taupe	Ink 3 Gray	Abacus Bariolage	Brunswick Solara	Foxtrot Sumo Quasar	Rivergrass		
Width x Height	Weight	Model Number	U.S. List Price	No Cost	+\$134	No Cost	No Cost	No Cost	+\$19	+\$24	+\$35	+\$16	
35.375" x 27.75"	40 lb	CEDHCR03627 Refer to Graphic A Markerboard on Right	\$498	No Cost	+\$134	No Cost	No Cost	No Cost	+\$19	+\$24	+\$35	+\$16	
35.375" x 27.75"	40 lb	CEDHCL03627 Refer to Graphic A Markerboard on Left	\$498	No Cost	+\$134	No Cost	No Cost	No Cost	+\$19	+\$24	+\$35	+\$16	
35.375" x 27.75"	40 lb	CEDHCR23627 Refer to Graphic B Markerboard on Right	\$498	No Cost	+\$134	No Cost	No Cost	No Cost	+\$19	+\$24	+\$35	+\$16	
35.375" x 27.75"	40 lb	CEDHCL23627 Refer to Graphic B Markerboard on Left	\$498	No Cost	+\$134	No Cost	No Cost	No Cost	+\$19	+\$24	+\$35	+\$16	



For Canadian Pricing
Multiply U.S. price by 1.05.
▶ See page 1 for details.

How to Specify Contractor Series Whiteboards and Tackboards

Model Number Logic

Example: **M1140054**

- 110 Series 60" x 48" markerboard

M	1140	054
M = Marker T = Tack	Frame Style (eg.110 Series)	Size Code

How to Specify

- 1 Model Number
- 2 Surface
- 3 Options

Markerboard Specification Tool

Step One: Select Size			Step Two: Select Surface		Step Three: Select Options			
Width X Height	Model Number	Specify 40 Markerboard U.S. List Price	No Cost	Optional	Optional			
48" x 36"	M1140043	\$265	7655	Screenprint	Spline Joint	1" Maprail	1" Map Hook/Clip (requires Maprail)	1" Flag Holder (requires Maprail)
48" x 48"	M1140044	\$307	High Gloss White	7658 Music Staff Lines	XSPL	MAPR	H1	FH1
60" x 48"	M1140054	\$367	No Cost	+\$166		+\$9	+\$2	+\$12
72" x 48"	M1140064	\$428	No Cost	+\$218		+\$13	+\$2	+\$12
96" x 48"	M1140084	\$537	No Cost	+\$274		+\$16	+\$4	+\$12
120" x 48"	M1140104	\$677	No Cost	+\$330		+\$21	+\$4	+\$12
144" x 48"	M1140124	\$799	No Cost	+\$440		+\$27	+\$4	+\$12
192" x 48"	M1140164	\$1,008	No Cost		+\$212	+\$37	+\$6	+\$12
			No Cost		+\$212	+\$45	+\$6	+\$12
			No Cost		+\$212	+\$60	+\$8	+\$12

M1140054	\$ 367	+	7658	\$ 274	+	MAPR	\$ 16	\$ 657
Model Number	Add List Price		Surface Number	Add Price		Option	Add Price	Total Cost



For Canadian Pricing
Multiply U.S. price by 1.05.
▶ See page 1 for details.

110 Contractor Series



Standard includes:

- 3/4" Clear Anodized aluminum frame with rounded edges on marker tray
- Aluminum full-width blade marker tray (markerboards only)
- e³ environmental ceramicsteel writing surface on markerboards
- Pack of four dry-erase markers (black, blue, red, and green) and one eraser
- Fabric over 3/8" fiberboard on tackboards

Options:

- Music Staff Lines screenprint option available on e³ environmental ceramicsteel writing surface on boards up to 8'.
- Spline joint allows markerboard to be shipped in two (2) pieces; requires on-site assembly.
- For more information on COM fabrics, see page 42. COM fabrics must be tested.
- 1" full-width Cork Maprail is available at an additional charge. Specify MAPR, Maprail.
- Clear Anodized Aluminum maprail-mounted accessories are available including: Map Hook and Flag Holder.
- For e³ care and maintenance instructions, see page 4.

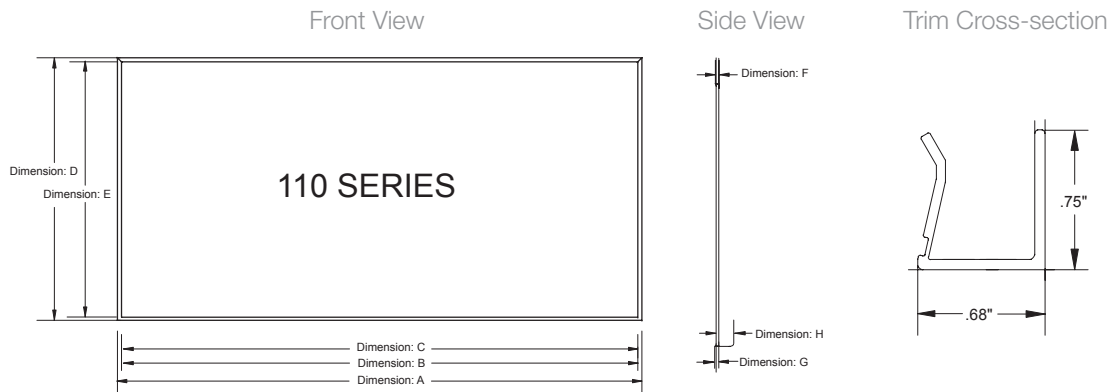

	Size Code	024	043	044	054	064	084	104	124	164
	Marker or Tack board		M or T	M or T	M or T	M or T	M or T	M	M	M
A	Overall Width		48" 1219mm	48" 1219mm	60" 1524mm	72" 1829mm	96" 2438mm	120" 3048mm	144" 3658mm	192" 4877mm
B	Surface Width		34.75" 883mm	46.75" 1187mm	58.75" 1492mm	70.75" 1797mm	94.75" 2407mm	118.75" 3016mm	142.75" 3623mm	190.75" 4845mm
C	Marker Tray Width		34.5" 876mm	46.5" 1181mm	58.5" 1486mm	70.5" 1791mm	94.5" 2400mm	118.5" 3010mm	142.5" 3620mm	190.5" 4839mm
D	Overall Height		36" 914mm	48" 1219mm	48" 1219mm	48" 1219mm	48" 1219mm	48" 1219mm	48" 1219mm	48" 1219mm
E	Surface Height		46.68" 1186mm	46.68" 1186mm	46.68" 1186mm	46.68" 1186mm	46.68" 1186mm	46.68" 1186mm	46.68" 1186mm	46.68" 1186mm
F	Frame Depth		0.68" 17mm	0.68" 17mm	0.68" 17mm	0.68" 17mm	0.68" 17mm	0.68" 17mm	0.68" 17mm	0.68" 17mm
G	Depth from Wall to Frame Face		0.81" 25mm	0.81" 25mm	0.81" 25mm	0.81" 25mm	0.81" 25mm	0.81" 25mm	0.81" 25mm	0.81" 25mm
H	Marker Tray Depth		2.69" 68mm	2.69" 68mm	2.69" 68mm	2.69" 68mm	2.69" 68mm	2.69" 68mm	2.69" 68mm	2.69" 68mm
	Weight LBS M/T Weight KGS M/T		35.3/25.1 16.0/11.4	47.0/33.5 21.3/15.2	58.8/41.9 26.7/19.0	70.5/50.3 32.0/22.8	94.0/67.0 42.6/30.4	117.5 53.3	141.0 64.0	188.0 85.3

Markerboard Specification Tool

①

Step One: Select Size		
Width X Height	Model Number	U.S. List Price
36" x 48"	M1140034	\$265
★ 48" x 36"	M1140043	\$265
★ 48" x 48"	M1140044	\$307
★ 60" x 48"	M1140054	\$367
★ 72" x 48"	M1140064	\$428
★ 96" x 48"	M1140084	\$537
★ 120" x 48"	M1140104	\$677
144" x 48"	M1140124	\$799
192" x 48"	M1140164	\$1,008

②

Step Two: Select Surface	
No Cost	Optional
7655	Screenprint
+	High Gloss White
No Cost	+\$166
No Cost	+\$166
No Cost	+\$218
No Cost	+\$274
No Cost	+\$330
No Cost	+\$440
No Cost	
No Cost	
No Cost	

③

Step Three: Select Options				
Optional				
Spline Joint	1" Maprail	1" Map Hook/Clip (requires Maprail)	1" Flag Holder (requires Maprail)	Roller Bracket (requires Maprail)
XSPL	MAPR	H1	FH1	RB1
	+\$9	+\$2	+\$12	+\$9
	+\$9	+\$2	+\$12	+\$9
	+\$13	+\$2	+\$12	+\$9
	+\$16	+\$4	+\$12	+\$9
	+\$21	+\$4	+\$12	+\$9
	+\$27	+\$4	+\$12	+\$9
+\$212	+\$37	+\$6	+\$12	+\$9
+\$212	+\$46	+\$6	+\$12	+\$9
+\$212	+\$60	+\$8	+\$12	+\$9

★ Quick Ship

Quick Ship available for boards 48", 72", 96", 144" wide by 48" high.

Tackboard Specification Tool

①

Step One: Select Size		
Width X Height	Model Number	U.S. List Price
36" x 48"	T1150034	\$218
48" x 36"	T1150043	\$218
48" x 48"	T1150044	\$262
60" x 48"	T1150054	\$312
72" x 48"	T1150064	\$341
96" x 48"	T1150084	\$403

②

Step One: Select Surface				
Specify Fabric Color Number				See page 42 for yardage information
Price Group 1	Price Group 2	Price Group 3	Price Group 4	COM
Abacus Bariolage	Brunswick Solara	Foxtrot Sumo Quasar	Rivergrass	
No cost	+\$38	+\$47	+\$68	+\$16
No cost	+\$38	+\$47	+\$68	+\$16
No cost	+\$38	+\$47	+\$68	+\$16
No cost	+\$45	+\$57	+\$86	+\$16
No cost	+\$50	+\$67	+\$104	+\$16
No cost	+\$52	+\$69	+\$113	+\$16



For Canadian Pricing
 Multiply U.S. price by 1.05.
 ▶ See page 1 for details.

555 Contractor Series



Standard includes:

- 1.25" Clear Anodized aluminum frame with safety corners
- Aluminum full-width box-style marker tray (markerboards only)
- e³ environmental ceramicsteel writing surface on markerboards
- Pack of four dry-erase markers (black, blue, red, and green) and one eraser
- Fabric over 3/8" fiberboard on tackboards

Options:

- Music Staff Lines screenprint option available on e³ environmental ceramicsteel writing surface on boards up to 8'.
- Spline joint allows markerboard to be shipped in two (2) pieces; requires on-site assembly.
- For more information on COM fabrics, see page 42. COM fabrics must be tested.
- 1" full-width Cork Maprail is available at an additional charge. Specify with MAPR, Maprail.
- Clear Anodized Aluminum maprail-mounted accessories are available including: Map Hook and Flag Holder.
- For e³ care and maintenance instructions, see page 4.

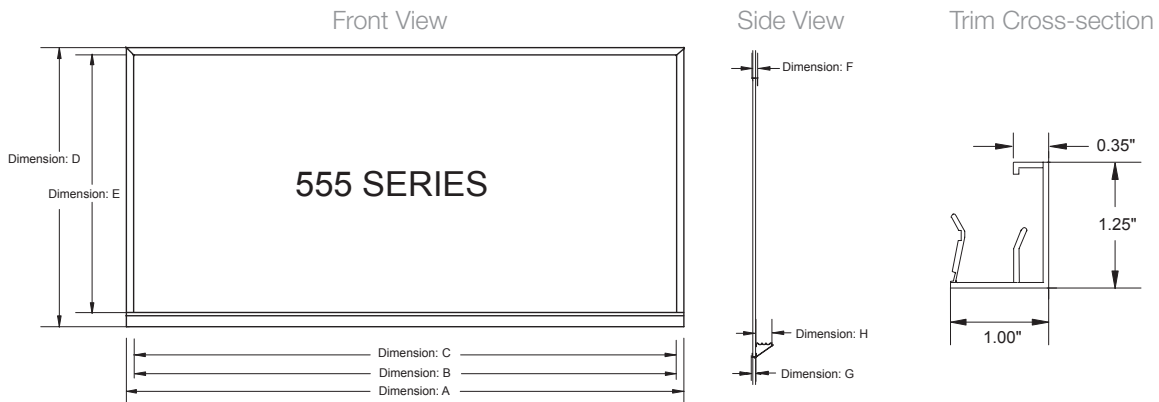

	Size Code	024	043	044	054	064	084	104	124	164
	Marker or Tack board		M or T	M or T	M or T	M or T	M or T	M	M	M
A	Overall Width		36.25" 921mm	48.25" 1225mm	60.25" 1530mm	72.25" 1835mm	96.25" 2445mm	120.25" 3054mm	144.25" 3664mm	192.25" 4883mm
B	Surface Width		33.75" 857mm	45.75" 1162mm	57.75" 1467mm	69.75" 1772mm	93.75" 2381mm	117.75" 2991mm	141.75" 3600mm	189.75" 4820mm
C	Marker Tray Width		33.5" 851mm	45.5" 1156mm	57.5" 1461mm	69.5" 1765mm	93.5" 2375mm	117.5" 2985mm	141.5" 3594mm	189.5" 4813mm
D	Overall Height		48.25" 1226mm	48.25" 1226mm	48.25" 1226mm	48.25" 1226mm	48.25" 1226mm	48.25" 1226mm	48.25" 1226mm	48.25" 1226mm
E	Surface Height		44.5" 1130mm	44.5" 1130mm	44.5" 1130mm	44.5" 1130mm	44.5" 1130mm	44.5" 1130mm	44.5" 1130mm	44.5" 1130mm
F	Frame Depth		1" 25mm	1" 25mm	1" 25mm	1" 25mm	1" 25mm	1" 25mm	1" 25mm	1" 25mm
G	Depth from Wall to Frame Face		1" 25mm	1" 25mm	1" 25mm	1" 25mm	1" 25mm	1" 25mm	1" 25mm	1" 25mm
H	Marker Tray Depth		2.75" 70mm	2.75" 70mm	2.75" 70mm	2.75" 70mm	2.75" 70mm	2.75" 70mm	2.75" 70mm	2.75" 70mm
	Weight LBS M/T Weight KGS M/T		36.8/25.9 16.7/11.7	49.0/34.5 22.2/15.7	61.3/43.1 27.8/19.6	73.5/51.8 33.3/23.5	98.0/69.0 44.5/31.3	122.5 55.6	147.0 66.7	196.0 88.9

Markerboard Specification Tool

Step One: Select Size			Step Two: Select Surface		Step Three: Select Options				
Width X Height	Model Number	U.S. List Price	No Cost	Optional	Optional				
			7655	Screenprint	Spline Joint	1" Maprail	1" Map Hook/Clip (requires Maprail)	1" Flag Holder (requires Maprail)	Roller Bracket (requires Maprail)
			High Gloss White	7658 Music Staff Lines	X SPL	MAPR	H1	FH1	RB1
36" x 48"	M5540034	\$298	No Cost	+\$166		+\$9	+\$2	+\$12	+\$9
48" x 36"	M5540043	\$298	No Cost	+\$166		+\$9	+\$2	+\$12	+\$9
48" x 48"	M5540044	\$339	No Cost	+\$218		+\$13	+\$2	+\$12	+\$9
60" x 48"	M5540054	\$401	No Cost	+\$274		+\$16	+\$4	+\$12	+\$9
72" x 48"	M5540064	\$481	No Cost	+\$330		+\$21	+\$4	+\$12	+\$9
96" x 48"	M5540084	\$598	No Cost	+\$440		+\$27	+\$4	+\$12	+\$9
120" x 48"	M5540104	\$755	No Cost		+\$212	+\$37	+\$6	+\$12	+\$9
144" x 48"	M5540124	\$887	No Cost		+\$212	+\$46	+\$6	+\$12	+\$9
192" x 48"	M5540164	\$1,152	No Cost		+\$212	+\$60	+\$8	+\$12	+\$9







Tackboard Specification Tool

Step One: Select Size			Step One: Select Surface				
Width X Height	Model Number	U.S. List Price	Specify Fabric Color Number				See page 42 for yardage information
			Price Group 1	Price Group 2	Price Group 3	Price Group 4	COM
			Abacus Bariolage	Brunswick Solara	Foxtrot Sumo Quasar	Rivergrass	
36" x 48"	T5550034	\$249	No cost	+\$38	+\$47	+\$68	+\$16
48" x 36"	T5550043	\$249	No cost	+\$38	+\$47	+\$68	+\$16
48" x 48"	T5550044	\$292	No cost	+\$38	+\$47	+\$68	+\$16
60" x 48"	T5550054	\$346	No cost	+\$45	+\$57	+\$86	+\$16
72" x 48"	T5550064	\$389	No cost	+\$50	+\$67	+\$104	+\$16
96" x 48"	T5550084	\$499	No cost	+\$52	+\$69	+\$113	+\$16



For Canadian Pricing
 Multiply U.S. price by 1.05.
 ▶ See page 1 for details.

Accessories

Name	Model Number	List Price	Size/Color	
Dry-Erase Markers 12 per box (1 color per box)	1MP12 2MP12 3MP12 4MP12	\$24 \$24 \$24 \$24	Black Blue Red Green	
Dry-Erase Markers 12 per box (3 of each color)	MP12	\$24	Black Blue Red Green	
Dry-Erase Markers 4 per pack (1 of each color)	MP4	\$9	Black Blue Red Green	
Magnetic Eraser with Marker Holder (Order marker separately)	MEP1	\$24	Not applicable	
Replacement Felt for Magnetic Eraser 5 per box	ERF5	\$5	Not applicable	
Eraser	RE1	\$6	Not applicable	
Magnetic Marker Tray* Clear Anodized Aluminum	MCR12 MCR24	\$49 \$66	12" 24"	
Magnetic Flipchart Holder* Clear Anodized Aluminum	CFFMFH30	\$173	28" x 2.57"	

All sizes are nominal.



*For use on e³ or painted steel surfaces only.

For e³ environmental ceramicsteel care and maintenance instructions, see page 4.

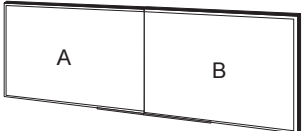

For Canadian Pricing
Multiply U.S. price by 1.05.
▶ See page 1 for details.

Important Application Information (Including Spline Joints)

<p>Sizes</p>	<p>Sizes of tackboards and markerboards are nominal, refer to dimensioned drawings for exact specifications.</p>																				
<p>Tackboards</p>	<ul style="list-style-type: none"> • Standard tackboard construction is $\frac{3}{8}$" fiberboard over $\frac{1}{8}$" hardboard. • COM fabrics may be specified. COMs must be approved. 																				
<p>Spline Joints</p> 	<ul style="list-style-type: none"> • Spline joints allow larger format boards to be delivered in 2 pieces. Assembly required. • Whiteboards weigh approximately 5lbs/ft² • Assembly required on-site. • Spline joints are an option, with upcharge on: Edge, Access, Denska, 110, and 555 markerboards over 10' in length. • Spline board joints are visible, every effort is made to ensure a tight seam. • Please be sure your client is aware that the spline joint will show. 																				
<p>Using CopyCam with Premium Whiteboards</p>	<ul style="list-style-type: none"> • CopyCam works with all Premium Whiteboards. IMPORTANT: Cables cannot be routed behind Senti, 110, or 555 Series boards. • CopyCam works with boards 8' (2.4m) or less in width. • CopyCam is only available in Champagne finish. 																				
<p>Magnetic Mount Option (MGMT)</p>	<ul style="list-style-type: none"> • Enables Senti boards, up to 48" x 48", to be mounted on flat, painted steel surfaces only. <p>NOTE: This mount is not intended for fabric or other coverings over steel.</p>																				
<p>Panel Mount Bracket Option (PLMT)</p> 	<ul style="list-style-type: none"> • Panel Mount Brackets enable Edge and Senti markerboards, up to 60" wide, to be mounted on any Steelcase system, except Montage, plus a selection of other systems. • Boards intended for panel-mount must be the same width as the panel on which they are to be mounted. <table border="1" data-bbox="618 1236 1443 1610"> <thead> <tr> <th>Option</th> <th>Description</th> </tr> </thead> <tbody> <tr> <td>PLMT00</td> <td>1" over panel bracket/hook</td> </tr> <tr> <td>PLMT01</td> <td>2" over panel bracket/hook</td> </tr> <tr> <td>PLMT02</td> <td>Avenir Panel bracket, must be modular with panel</td> </tr> <tr> <td>PLMT03</td> <td>3" over panel bracket/hook</td> </tr> <tr> <td>PLMT35</td> <td>3.5" over panel bracket/hook</td> </tr> <tr> <td>PLMT04</td> <td>Answer/Kick/Privacy Wall bracket, must be modular with panel</td> </tr> <tr> <td>PLMT05</td> <td>Series 9000 Panel bracket, must be modular with panel</td> </tr> <tr> <td>PLMT06</td> <td>Knoll Morrison Panel bracket, must be modular with panel</td> </tr> <tr> <td>PLMT07</td> <td>Hauserman Panel bracket, must be modular with panel</td> </tr> </tbody> </table>	Option	Description	PLMT00	1" over panel bracket/hook	PLMT01	2" over panel bracket/hook	PLMT02	Avenir Panel bracket, must be modular with panel	PLMT03	3" over panel bracket/hook	PLMT35	3.5" over panel bracket/hook	PLMT04	Answer/Kick/Privacy Wall bracket, must be modular with panel	PLMT05	Series 9000 Panel bracket, must be modular with panel	PLMT06	Knoll Morrison Panel bracket, must be modular with panel	PLMT07	Hauserman Panel bracket, must be modular with panel
Option	Description																				
PLMT00	1" over panel bracket/hook																				
PLMT01	2" over panel bracket/hook																				
PLMT02	Avenir Panel bracket, must be modular with panel																				
PLMT03	3" over panel bracket/hook																				
PLMT35	3.5" over panel bracket/hook																				
PLMT04	Answer/Kick/Privacy Wall bracket, must be modular with panel																				
PLMT05	Series 9000 Panel bracket, must be modular with panel																				
PLMT06	Knoll Morrison Panel bracket, must be modular with panel																				
PLMT07	Hauserman Panel bracket, must be modular with panel																				

TRIM:

Wood Trim Finishes

The wood finish is an open pore, high gloss finish on maple, cherry or walnut. Colors match current Steelcase wood finishes in color only and do not match the Steelcase finish in sheen.

SURFACES:

Markerboards

Markerboards are standard in white high-gloss 7655 e³ environmental ceramicsteel. Optional screenprint patterns are available to provide a guide for writing or drawing. See page 48 for patterns.

Fabric Tackboard Surfaces

Tackboard surfaces are available in select Steelcase and DesignTex fabrics; pricing for DesignTex and Steelcase fabrics is determined by a grading program. All fabrics are applied railroaded, i.e. salvages parallel to floor.

Customers Own Material (COM)

Fabric Approval and Yardage

To confirm whether a particular COM material has already been tested for use on a specific Steelcase product or to determine actual yardage requirements:

- Visit www.steelcase.com

For additional information regarding Customer's Own Material, call 1.888. STEELCASE.

Surface Materials

This list includes all surface material and/or finish choices applicable to Premium Whiteboards and Tackboards and Contractor Series. Not all surface material and/or finish choices are available on all products. Please refer to the Finish Matrices see pages 44 and 45 for specific product availability.

TRIM

METAL TRIM

8043	Clear Anodized Aluminum
8044	Black Anodized Aluminum
4750	Champagne
4799	Platinum Silver
0835	Black
4798	Sterling

WOOD TRIM

3412	Natural Cherry on Cherry
3422	Medium Cherry on Cherry
3572	Amber on Maple
3592	Blonde on Maple
3712	Natural Walnut on Walnut
3772	Medium Mahogany on Walnut

MARKERBOARD SURFACE

Standard:

7655	White e ³ environmental ceramicsteel
------	---

Optional Screenprint on e³ environmental ceramicsteel:

7656	Circular Dot Pattern 2"
7657	Grid Pattern 2"
7658	Music Staff Lines (5 lines per staff)

FABRIC TACKABLE SURFACE

CLASSICS COLLECTION

Price Group 1:

Abacus

P122	Entasis
P123	Portico
P124	Opus
P125	Cusp
P126	Artifact
P127	Arcade
P128	Matrix
P129	Atlas
P156	Pilaster

Steelcase

Bariolage

G220	Etude
G221	Antante
G226	Cantata
G227	Adagio
G235	Sonata
G233	Melody
G234	Ballala

DESIGNTEX GRADED-IN PROGRAM

Price Group 2:

Brunswick
Solara

Price Group 3:

Foxtrot
Sumo
Quasar

Price Group 4:

Rivergrass

Surface Material Application Matrix

About Finishes: You must select a Trim Finish and a Surface Finish to complete your specification.

Trim Options

					Premium Wood Trim					
Model No.	8043	4750	4799	0835	3412	3422	3572	3592	3712	3772
Selection	Clear Anodized Aluminum	Champagne	Platinum	Black	Natural Cherry on Cherry	Medium Cherry on Cherry	Amber on Maple	Blonde on Maple	Natural Walnut on Walnut	Medium Mahogany on Walnut
Senti	<input type="checkbox"/>									
Edge	<input type="checkbox"/>	\$								
Access	<input type="checkbox"/>	\$		●						
Denska				●	<input type="checkbox"/>	<input type="checkbox"/>	<input type="checkbox"/>	<input type="checkbox"/>	<input type="checkbox"/>	<input type="checkbox"/>
Session					<input type="checkbox"/>	<input type="checkbox"/>	<input type="checkbox"/>	<input type="checkbox"/>	<input type="checkbox"/>	<input type="checkbox"/>
FreeFlow	<input type="checkbox"/>									
Echo	<input type="checkbox"/>									
PinMag			<input type="checkbox"/>	<input type="checkbox"/>						
110 Series	<input type="checkbox"/>									
555 Series	<input type="checkbox"/>									

Key Information

- * Wood coordinates with Steelcase Wood. Finish matches are for color only and do not match the Steelcase finishes in sheen.
- Standard finish selection.
- \$ This finish option has an upcharge.
- These products have a black frame as standard. Finish options are for INSERT only.

Surface Options

e ³ environmental ceramicsteel Whiteboard Surface					Fabric Tackable Surface				
Standard		Screenprint Options: Upcharge Not available on all sizes.			Fabric Options: Upcharge				
Model No.	7655	7656	7657	7658	Price Group 1	Price Group 2	Price Group 3	Price Group 4	COM
Selection	White Highgloss	Circular Dot Pattern	2" Grid Pattern	Music Staff Lines 5 Lines/Staff					
Senti	<input type="checkbox"/>	\$	\$						
Edge	<input type="checkbox"/>	\$	\$		<input type="checkbox"/>	\$	\$	\$	◇
Access	<input type="checkbox"/>	\$	\$		<input type="checkbox"/>	\$	\$	\$	◇
Denska	<input type="checkbox"/>	\$	\$						
Session	<input type="checkbox"/>	\$	\$		<input type="checkbox"/>	\$	\$	\$	◇
FreeFlow	<input type="checkbox"/>	\$	\$		<input type="checkbox"/>	\$	\$	\$	◇
Echo									
PinMag					<input type="checkbox"/>	\$	\$	\$	◇
110 Series	<input type="checkbox"/>			\$	<input type="checkbox"/>				
555 Series	<input type="checkbox"/>			\$	<input type="checkbox"/>				

Key Information

- Standard finish selection.
- \$ This finish option has an upcharge.
- ◇ Customer's own material, see page 42.

For Grade-in fabric selection, see page 43.

PPPW Bracket Application Guide

- On and Off Module Bracket for installation of markerboards and tackboards on Privacy Wall, Answer and Kick.
- Allows Premium Whiteboards to be mounted on Privacy Wall, Answer, or Kick using a standard metal cleat mounting system.
- Ideal application on a Privacy Wall or when spanning multiple Answer/Kick panels with a single markerboard.
- Compatible with boards 48" high only.
- Not for use with Senti, FreeFlow, or Contractor Series.
- Cannot install two boards at right angles.
- Ships with six non-handed brackets for maximum application flexibility; field-modify for application by removing tabs per instructions.
- The required minimum number of PPPW Brackets must be installed to ensure secure application of board.
- Brackets must be installed in the correct orientation. i.e. left or right hand, as indicated in the key below, photo right, and diagrams below and on page 47.

NOTE: Space between panel face and rear of board is $\pm 0.25"$.



Tab Removal – Right Hand Application

KEY:

- > Right Hand Application of PPPW Bracket
- < Left Hand Application of PPPW Bracket

Standard Mounting Height and Centerline Application

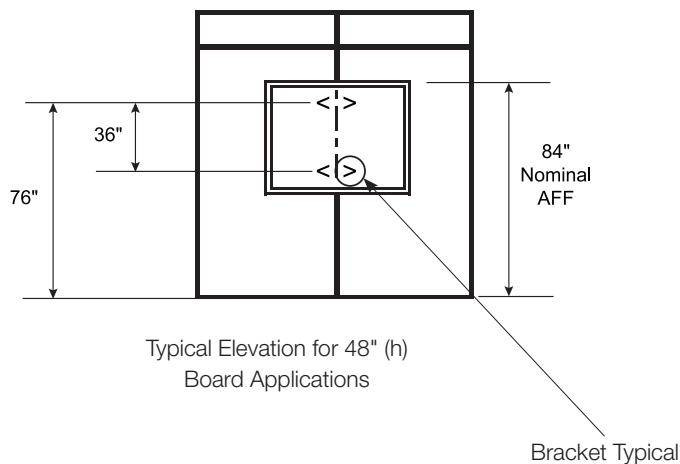

- For boards up to 16' wide
- 48" in height only

KEY:

- > Right Hand Application of PPPW Bracket
- < Left Hand Application of PPPW Bracket

On Module – Minimum Bracket Application

Board Width (inches)	48	60	72	84	96	120	144	168	192
Minimum Number of Brackets	4	4	4	4	4	4	6	6	6

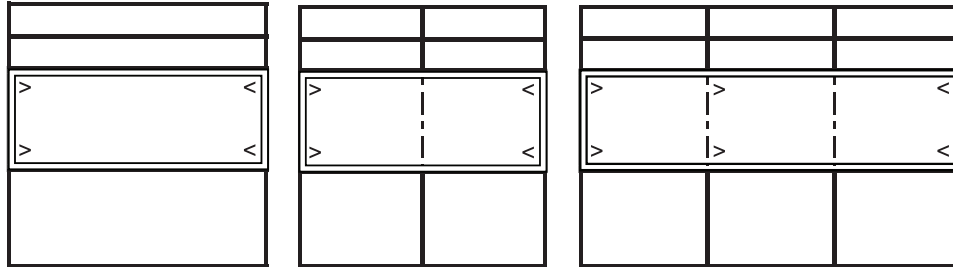

Asymmetrical Off Module Overhang Allowances and Minimum Bracket Application

Board Width (inches)	60	72	84	96	120	144	168	192
Minimum Number of Brackets	4	4	4	4	4	6	6	6
Dimension A – Maximum Overhang (inches)	18	22	25	29	36	38	38	38

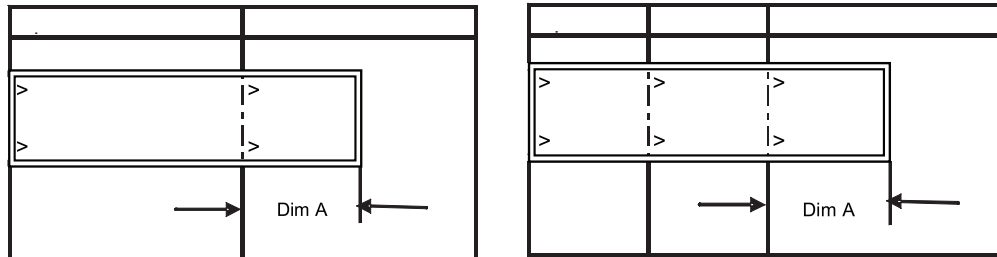

NOTE: Bracket direction must be the same as the overhang direction. This example shows right hand bracket installation with right hand overhang.

Symmetrical Off Module Overhang Allowances and Minimum Bracket Application

Board Width (inches)	60	72	84	96	120	144	168	192
Minimum Number of Brackets	4	4	4	4	4	6	6	6
Dimension B – Maximum Overhang (inches)	18	22	25	29	36	38	38	38

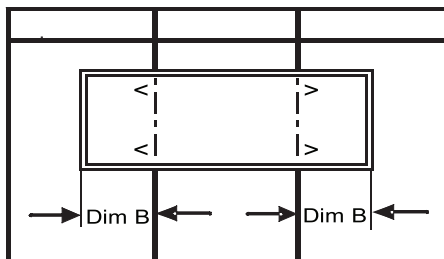

NOTE: Dimension B must be equal on both the left and the right. For example, a 60" board may have a maximum 18" overhang both left and right side.

Screenprint Options

A selection of standard screenprint options are offered. Custom screenprint is also available. Screenprint graphics are permanently fused to the e³ environmental ceramicsteel surface. Screenprint is not available on boards with spline joints.

Standard Screenprint Options

Premium Whiteboards

Up to 10' Wide:



7655
e³ White

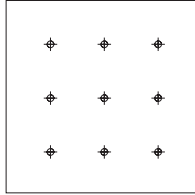

7656
Circular Dots
at 2" Intervals

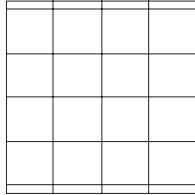

7657
2" x 2"
Grid Pattern

Contractor Series Whiteboards

Up to 8' Wide:

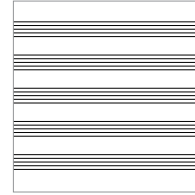

7658
Music Staff Lines
5 Lines per Staff

Standard Screenprint Options for Markerboards

Markerboards are available in white high gloss 7655 e³ environmental ceramicsteel. Optional screenprint patterns are available to provide a guide for writing or drawing. Screenprint is not visible at a distance of three 3' (0.9 meters), with the exception of Music Staff Lines which are printed in black.

Custom Screenprint Options for Markerboards

Custom screen printing is available in single or multiple colors on e³ environmental ceramicsteel. This service is available for both customer-provided artwork and Steelcase Visual Worktools standard artwork. Extended lead times apply. Artwork options include, but are not limited to:

- Planning boards
- Hospital boards
- Educational boards
- Corporate graphics and logos

Please refer to screenprint guidelines.

Resources

	
Style Number Index.....	50

Style Number Index

Style Number	Page	Description
1MP12	40	Markers-Dry Erase
2MP12	40	Markers-Dry Erase
3MP12	40	Markers-Dry Erase
4MP12	40	Markers-Dry Erase
CACM032	15	Markerboard-Access
CACM043	15	Markerboard-Access
CACM044	15	Markerboard-Access
CACM054	15	Markerboard-Access
CACM064	15	Markerboard-Access
CACM084	15	Markerboard-Access
CACM104	15	Markerboard-Access
CACM124	15	Markerboard-Access
CACM164	15	Markerboard-Access
CACML032	31	Combo Board-Access
CACML044	31	Combo Board-Access
CACML054	31	Combo Board-Access
CACML064	31	Combo Board-Access
CACML084	31	Combo Board-Access
CACML104	31	Combo Board-Access
CACML124	31	Combo Board-Access
CACMR032	31	Combo Board-Access
CACMR044	31	Combo Board-Access
CACMR054	31	Combo Board-Access
CACMR064	31	Combo Board-Access
CACMR084	31	Combo Board-Access
CACMR104	31	Combo Board-Access
CACMR124	31	Combo Board-Access
CACT043	15	Tackboard-Access
CACT044	15	Tackboard-Access
CACT054	15	Tackboard-Access
CACT064	15	Tackboard-Access
CACT084	15	Tackboard-Access
CACT104	15	Tackboard-Access
CDEM032	17	Markerboard-Denska
CDEM043	17	Markerboard-Denska
CDEM044	17	Markerboard-Denska
CDEM054	17	Markerboard-Denska
CDEM064	17	Markerboard-Denska
CDEM084	17	Markerboard-Denska
CDEM104	17	Markerboard-Denska
CDEM124	17	Markerboard-Denska
CDEM164	17	Markerboard-Denska
CECHO6	24	Projection Screen-Echo
CECHO8	24	Projection Screen-Echo
CEDH01827	33	Markerboard-Patient Room
CEDH21827	33	Markerboard-Patient Room
CEDHCL03627	33	Combo Board-Patient Rm
CEDHCL23627	33	Combo Board-Patient Rm
CEDHCR03627	33	Combo Board-Patient Rm
CEDHCR23627	33	Combo Board-Patient Rm
CEDM0218	13	Markerboard-Edge
CEDM032	13	Markerboard-Edge
CEDM043	13	Markerboard-Edge
CEDM044	13	Markerboard-Edge
CEDM054	13	Markerboard-Edge

Style Number	Page	Description
CEDM064	13	Markerboard-Edge
CEDM084	13	Markerboard-Edge
CEDM104	13	Markerboard-Edge
CEDM124	13	Markerboard-Edge
CEDM164	13	Markerboard-Edge
CEDML0218	31	Combo Board-Edge
CEDML032	31	Combo Board-Edge
CEDML044	31	Combo Board-Edge
CEDML054	31	Combo Board-Edge
CEDML064	31	Combo Board-Edge
CEDML084	31	Combo Board-Edge
CEDML104	31	Combo Board-Edge
CEDML124	31	Combo Board-Edge
CEDMR0218	31	Combo Board-Edge
CEDMR032	31	Combo Board-Edge
CEDMR044	31	Combo Board-Edge
CEDMR054	31	Combo Board-Edge
CEDMR064	31	Combo Board-Edge
CEDMR084	31	Combo Board-Edge
CEDMR104	31	Combo Board-Edge
CEDMR124	31	Combo Board-Edge
CEDT043	13	Tackboard-Edge
CEDT044	13	Tackboard-Edge
CEDT054	13	Tackboard-Edge
CEDT064	13	Tackboard-Edge
CEDT084	13	Tackboard-Edge
CEDT104	13	Tackboard-Edge
CFFBT	23	Bottom Rail-Freeflow Track
CFFF	23	Holder-Flipchart, Track System
CFFM064	21	Markerboard-Freeflow
CFFM084	21	Markerboard-Freeflow
CFFM104	21	Markerboard-Freeflow
CFFM124	21	Markerboard-Freeflow
CFFM164	21	Markerboard-Freeflow
CFFMFH30	23, 40	Holder-Flipchart, Magnetic
CFFSCR49	23	Projection Screen-Freeflow
CFFSCR56	23	Projection Screen-Freeflow
CFFSCR64	23	Projection Screen-Freeflow
CFFSMB034	23	Markerboard-Freeflow, Double Sided
CFFSTB034	23	Tackboard-Freeflow, Double Sided
CFFT	23	Rail-Freeflow System
CPMT0218	25	Tackboard-Pin Mag
CPMT032	25	Tackboard-Pin Mag
CPMT043	25	Tackboard-Pin Mag
CSEM043	19	Markerboard-Session
CSEM044	19	Markerboard-Session
CSEM054	19	Markerboard-Session
CSEM064	19	Markerboard-Session
CSEM084	19	Markerboard-Session
CSEM104	19	Markerboard-Session
CSEML043	31	Combo Board-Session
CSEML044	31	Combo Board-Session
CSEML054	31	Combo Board-Session
CSEML064	31	Combo Board-Session
CSEML084	31	Combo Board-Session

Style Number	Page	Description
CSEML104	31	Combo Board-Session
CSEMR043	31	Combo Board-Session
CSEMR044	31	Combo Board-Session
CSEMR054	31	Combo Board-Session
CSEMR064	31	Combo Board-Session
CSEMR084	31	Combo Board-Session
CSEMR104	31	Combo Board-Session
CSET043	19	Tackboard-Session
CSET044	19	Tackboard-Session
CSET054	19	Tackboard-Session
CSET064	19	Tackboard-Session
CSET084	19	Tackboard-Session
CSET104	19	Tackboard-Session
CSTM0218	11	Markerboard-Senti
CSTM032	11	Markerboard-Senti
CSTM043	11	Markerboard-Senti
CSTM044	11	Markerboard-Senti
CSTM054	11	Markerboard-Senti
CSTM064	11	Markerboard-Senti
ERF5	40	Felt-Replacement For Magnetic Eraser
GCJWT48	29	Rail-Worktool
GCJWT96	29	Rail-Worktool
K5M1P3242	29	Combination Board-Large
K5M2332	29	Markerboard-Small
K5M3242	29	Markerboard-Large
K5P3242	29	Board-Photo Album
KLG	29	Grabbers-Ledge
KME	29	Easel-Mobile
KMGRIP	29	Grip-Marker
KPEG	29	Pegs-Flip Chart
KPMT36	29	Tray-Panel Mounted
KPMT48	29	Tray-Panel Mounted
KPMT72	29	Tray-Panel Mounted
KSM2332	29	Markerboard-Small
KSM3242	29	Markerboard-Large
M1140034	37	Markerboard-110 Series
M1140043	37	Markerboard-110 Series
M1140044	37	Markerboard-110 Series
M1140054	37	Markerboard-110 Series
M1140064	37	Markerboard-110 Series
M1140084	37	Markerboard-110 Series
M1140104	37	Markerboard-110 Series
M1140124	37	Markerboard-110 Series
M1140164	37	Markerboard-110 Series
M5540034	39	Markerboard-555 Series
M5540043	39	Markerboard-555 Series
M5540044	39	Markerboard-555 Series
M5540054	39	Markerboard-555 Series
M5540064	39	Markerboard-555 Series
M5540084	39	Markerboard-555 Series
M5540104	39	Markerboard-555 Series
M5540124	39	Markerboard-555 Series
M5540164	39	Markerboard-555 Series
MCR12	40	Tray-Magnetic, Marker
MCR24	40	Tray-Magnetic, Marker

Style Number	Page	Description
MEP1	40	Eraser-Magnetic, With Marker Holder
MP12	40	Markers-Dry Erase
MP4	40	Markers-Dry Erase
RE1	40	Eraser-Regular
T1150034	37	Tackboard-110 Series
T1150043	37	Tackboard-110 Series
T1150044	37	Tackboard-110 Series
T1150054	37	Tackboard-110 Series
T1150064	37	Tackboard-110 Series
T1150084	37	Tackboard-110 Series
T5550034	39	Tackboard-555 Series
T5550043	39	Tackboard-555 Series
T5550044	39	Tackboard-555 Series
T5550054	39	Tackboard-555 Series
T5550064	39	Tackboard-555 Series
T5550084	39	Tackboard-555 Series

Trademark List

- ® The following registered trademarks are used under license from Steelcase Development Corporation: Accelerate, Ally, Answer, Anthem, Arrondi, Avenir, Ballet, Bix, Brayton International Collection, Brayton Textile Collection, Cachet, Canto, Chancellor, Company, Context, CopyCam, Criterion, Crushed Can, Designtex, Details, Drive, Elective Elements, Ellipse, Ember Chrome, Emerge, Etude, Exclamation Mark, Firstfile, Gentry, Ginkgo, Ginkgo Biloba, Hardwear, Ideo, Internode, Jersey, Kart, Kick, LaCosta, Latour, Leap, Let's B, LiveBack, Lyra, Lytyn, Manhattan Product Configuration, Max-Stacker, Media Dock, Metro, Migrations, Miko, Montage, Oriana, Parade, Pathways, Perfect Match, Player, PolyVision, Power Pincher, Portal, Protégé, Raf System, Rally, Relevant, Sensor, Series 9000, Springboard, Steelcase, Steelcase Design Partnership, Steelcase Workplace Performance, Stow Davis, TeamWork, Technique, Texpress, Think, Treehouse, Turnstone, Vecta, Vectaflex, Werndl, and Wizard.
- ® The following is a registered trademark of Byrne Electrical, Rockford, MI: Interport.
- ® The following is a registered trademark of DuPont, Wilmington, DE: Corian.
- ® The following is a registered trademark of Genlyte Thomas Company, Louisville, KY: Lightolier.
- ® The following is a registered trademark of Hilti Corporation, FL-9494 Schaan, Principality of Liechtenstein: Hilti.
- ® The following is a registered trademark of Leviton Manufacturing Company, Little Neck, NY: Decora.
- ® The following is a registered trademark of Mechanical Plactics Corp, Elmsford, NY: Toggler.
- ® The following is a registered trademark of Microsoft Corporation, Redmond, WA: Microsoft.
- ® The following is a registered trademark of Panduit Corporation, Lockport, IL: Panduit.
- ® The following is a registered trademark of PolyVision Corporation, Suwanee, GA: P³ ceramicsteel.
- ® The following is a registered trademark of Trav (Press), Cuneo, Italy: Assisa.
- ® The following is a registered trademark of Virtual Ink, Boston, MA: mimioActive.
- ® The following registered trademarks are under license from Wilkhahn Furniture Products: Avera, Confair, Senzo, Versal, and Wilkhahn FS.
- ® The following is a registered trademark of Wilsonart International, Temple, TX: Chemsurf.
- ® The following is a registered trademark of Wiremold, West Hartford, CT: Wiremold.

- ™ The following trademarks are used under license from Steelcase Development Corporation: 4 o'clock, à la carte, Access, Active/Passive Shelf, Adia, Airtouch, Alcove, Alerion, Alexander Street Collection, alight, Aliso, Allegro, Alongside, Amaris, American Elect, American Tradition, Anson, Arbor, Archipelago, Archive Collection, Arriva, Asana, Ascot, Aspekt, Astor, Austin, Avalon, Bira, Bonn, Boomerang, Bradbury, Breadbox, Brio, Brook, Burton, Buxton, Calla, Callahan, Camber, Canopy, Cappucino, Catalina, CbP, Chester, Chorus, Chronos, Ciao, Clarendon, Classic Rectangular, Collaboration, Collins, Cologne, Colorbox, Common (Shelf), Commons, Community, Community based Planning CbP, Convene, Convey, Cortex, Cosima, Croix, Cubby, Cubis, Cushion, Customiz, Cypress, Dataduct, Datum, Davenport, Deck, Dedoes, Déjà, Denska, Detour, Detriana, DNA, Domain, Donovan, Dorchester, Downspout, Drop Top Hutch, Dune, Duo, Duospace, Eastlake, Eastridge, Echo, Edge, Ella, Elsa, Emmy, Empress, Encounter, Enea, EnSync, Ensemble, Entourage, Environmental Impact Collection, Equinox, Escapade, Estate, Et Al, E-Table, Exchange, Exponents, Express12, Extreme Conditions, Fillmore, Flat Top, Fling, Flip Top, Flute, Footnote, Fortuna, FreeFlow, Frontier, Fuji, Futu, Galilei, Galveston, Garland, Ginger, Glenwood, Go Wall, Greco, Greenbrier, Grip, Groove, Groupwork, Hannah, Hatch, Hatchback, Hatteras, Hawthorne, Health Design, Hitch, Huddleboard, Impact, Incognito, Indy, InfoWizard, InterAct, IOS, I-Solve, Jacket, Jarrah, Jenny, Jetty, Juice, Kami, Kendo, Kiana, L'Attitude, Lavender, Lazlo, Lean Too, Lemon, Lift-N-Slide, Linden, LiveSeat, Loria, Lotus, Lyric, M/O, Malibu, Manhattan, Mansfield, Marathon, Martini, Mason, Masque, Mineral, Mingle, Mystic, Mystic Metal, Mystic Wood, Mitra, Monterey, Montreal, Move, MyWizard, Nadia, Nickel, Nikko, Nine, Norfolk, Nurture, Ontrak, Onyx, Opus, Orchid, Outlook, Paloma, Parliament, Parts Advantage, Pasio, Passarelle, Patriarch, Patterson, Payback, PCT, Peek, Pendio, Personal Border, Pier Top, Pin-Mag, Pipe, Pisa, Playback, Portal, Progeny, R2, Radio, Rag Top, Reed, Rei, Reunion, Rhine, Rialto, Ricetta, Riser, Rizzi Arc, Rocco, RoomWizard, Rover, Runaround, Runner, Satellite, Scribe, Senti, Sentinel, Sequoia, Session, Shadow, Shield, Shortbed, Sidebar, Sidewalk, Siento, Sieste, Simpatico, Sine, Skinny, Skylar, Slumber, Smoke, Snug, Softwork, Sorrel, Spinz, Sportswear, Stationkits, Stiletto, Stuttgart, Super Shelf, Surprise!, Switch, Symphony, Template, Terrazzo, Tessare, Theorem, Topaz, Topo, Top Spin, Touchdown, Tour, Train, Trillium, Trolly, T-Wall, Umbrella, Underline, Unison, Uno, Venetia, Verge, Viridian, Walden, Warehouse, Whittier, Windsor, Wizard WebSigns, Woodruff, X-tenz, Your Profile, Your Power, and Your Preference.

- ™ The following is a trademark of Microsoft Corporation, Redmond, WA: Windows.
- ™ The following trademarks are under license from PolyVision Corporation, Suwanee, GA: e³ environmental ceramicsteel and e³ ceramic-steel.
- ™ The following is a trademark of Rodman Industries, Inc., Oconomowoc, WI: ResinCore1.
- ™ The following is a trademark of Ultrafabrics, LLC, Elmsford, NY: Ultraleather.
- ™ The following trademarks are used under license from Wilkhahn Furniture: Cana, Linus, Logon, Picto, Range, Stitz, Thema, Timetable, and Tubis.
- ™ The following is a trademark of MBDC, Charlottesville, VA: Cradle to Cradle.