



Right-hinged

BS 260 610

Stainless steel-backed full glass door

Width 30" (76 cm)

BS 260 630

Aluminum-backed full glass door

Width 30" (76 cm)

Left-hinged

BS 261 610

Stainless steel-backed full glass door

Width 30" (76 cm)

BS 261 630

Aluminum-backed full glass door

Width 30" (76 cm)

Included accessories

- 1 meat probe.
- 1 stainless steel cooking insert, unperforated and 1 1/2" deep.
- 1 stainless steel cooking insert, perforated and 1 1/2" deep.
- 1 wire rack.

Optional accessories

GN 114 230

Stainless steel cooking insert, unperforated, 1 1/2" deep.

GN 124 230

Stainless steel cooking insert, perforated, 1 1/2" deep.

GR 220 046

Wire rack.

GN 114 130

Stainless steel cooking insert, unperforated, 1 1/2" deep, half tray size.

GN 124 130

Stainless steel cooking insert, perforated, 1 1/2" deep, half tray size.

GN 410 130

Stainless steel lid, 1 1/2" deep, half tray size.

GN 410 230

Stainless steel lid, 1 1/2" deep, full tray size.

GN 340 230

Non-stick aluminum cast-iron roaster, 4" deep, with 2 1/2" lid.

200 series Combi-steam oven

BS 260/261

- An extra wide 30" for combination with BO 280/1 single oven.
- Cooking with steam and without pressure at humidity levels from 0 to 100% and temperatures up to 450°F. With meat probe. Professional cooking technology for the home.
- No water connection necessary. Suitable for easy integration into existing kitchens.

Net volume 1.5 cu.ft.

Cooking methods

Steaming without pressure

(100% humidity, 212°F).

Convection from 85°F to 450°F at variable humidity levels of 0%, 30%, 60%, 80% or 100%.

Cooking modes: combi-steaming, steam baking, juice extraction, low temperature steaming, low temperature cooking.

Refreshing.

Defrosting.

Proofing.

Electronic precision temperature control.

Features

LCD function display with digital clock.

Timer functions: cooking time, shut off time, short-term timer, stop watch, sabbath mode.

Rotary knobs and touch key operation.

Removable 44 oz (1.3 liter) water tank.

Up to 3 hours full steam.

Water level warning.

Meat probe with automatic shut off.

Actual temperature display.

Automatic boiling point detection.

Menu settings.

60 W halogen light on the side.

Hygienic stainless steel cooking interior.

Four rack levels.

Side-opening door opens up to 180° angle.

Safety

Child lock.

Safety lock.

Cooled housing with temperature protection.

Cleaning

Cleaning program.

Drying program.

Descaling program.

Grease filter in front of convection fan.

Planning notes

Door hinge not reversible.

The front of the appliance extends 1 7/8" from the cabinet front.

The outer edge of the door handle extends 3 11/16" from the cabinet front.

When planning a corner solution, pay attention to the 90° door opening angle.

Consider the overhang, incl. the door handle, when planning to open drawers next to the appliance. Plan a gap of at least 3/16" between the appliance and adjacent cabinets.

To achieve the 21 5/8" installation depth, the connecting cable needs to follow the slanted edge on the lower left hand corner of the housing and then be led up. The power outlet needs to be planned outside of the niche.

No drainage needed.

Rating

Total connected load 1.95 kW.

comes with 47" connecting cable.

208/220-240V / 60Hz

Total Amps: 10

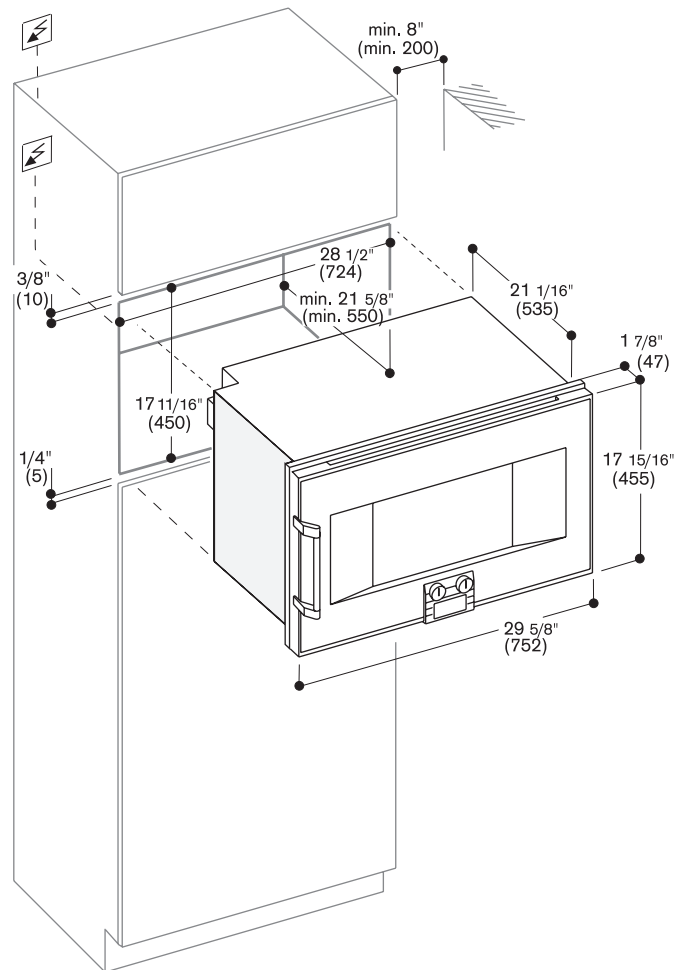

Numbers indicated inside parenthesis () = mm