



AW 200 792

Stainless steel
Width 36" (90 cm)
Air extraction/recirculation

**Installation accessories
for exhaust air mode**

AD 010 012
Stainless steel duct cover,
7' 5" - 8' 8" (2.25 - 2.64 m)

AD 010 022
Stainless steel duct cover,
8' 8" - 9' 11" (2.64 - 3.02 m)

**Installation accessories
for recirculation mode**

AD 010 112
Stainless steel duct cover,
7' 9" - 8' 8" (2.36 - 2.64 m)

AD 010 122
Stainless steel duct cover,
8' 8" - 9' 11" (2.64 - 3.02 m)

KF 001 010
Activated charcoal filter

**Wall hood
AW 200**

- Classic Gaggenau design.
- Air extration or recirculation system.
- Balance at a high level. High air output with minimal sound.
- Adjustable 60 watt soft halogen light: From bright to subdued lighting.

Output

Unobstructed air flow:
405 CFM with ø 6".

Sound pressure level:
57 dB (re 1 pW).

Features

Three electronically controlled speeds and intensive mode, interval ventilation, delayed shut-off function, grease filter saturation indicated by flashing light. Stainless steel grease filter, dishwasher-safe. Soft-Light.

Planning notes

Plan electrical connection behind the duct cover. Minimum clearance from gas and electric appliances: 30". The dimensions of the duct covers refer to a distance of 63" from the floor to the bottom edge of the hood. Convert for other installation heights: worktop height + minimum clearance + hood with duct.

Rating

Total rating: 220 W
Connecting cable: 47"
Total Amps: 2
120V / 60Hz

Exhaust air:

AD 010-012 = 25 9/16" - 40 15/16" (650 - 1040)

AD 010-022 = 40 15/16" - 56 3/16" (1040 - 1430)

Recirculating air:

AD 010-112 = 29 15/16" - 40 15/16" (760 - 1040)

AD 010-122 = 40 15/16" - 56 3/16" (1040 - 1430)

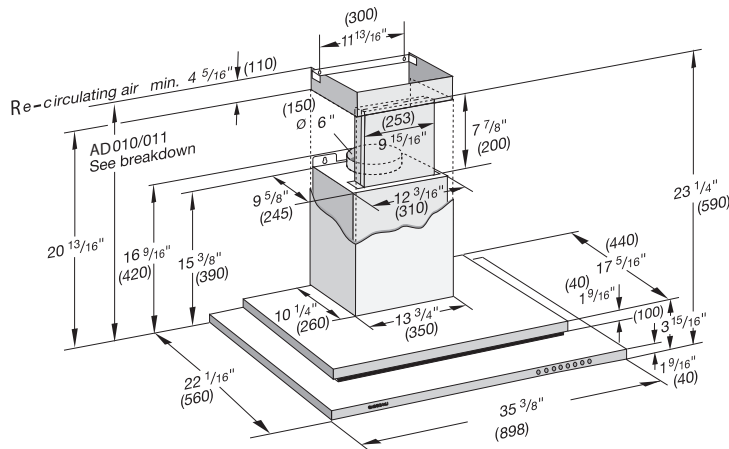

Numbers indicated
inside parenthesis () = mm