

# Installation Instructions

## Joint Systems: 120 -A01/A02

**Note:** Verify that the structural gap is in conformance with submittal data before beginning installation. If this is a Fire Rated Assembly, install the fire barrier before the Architectural Joint System. Refer to the fire barrier instructions for specific system installation.

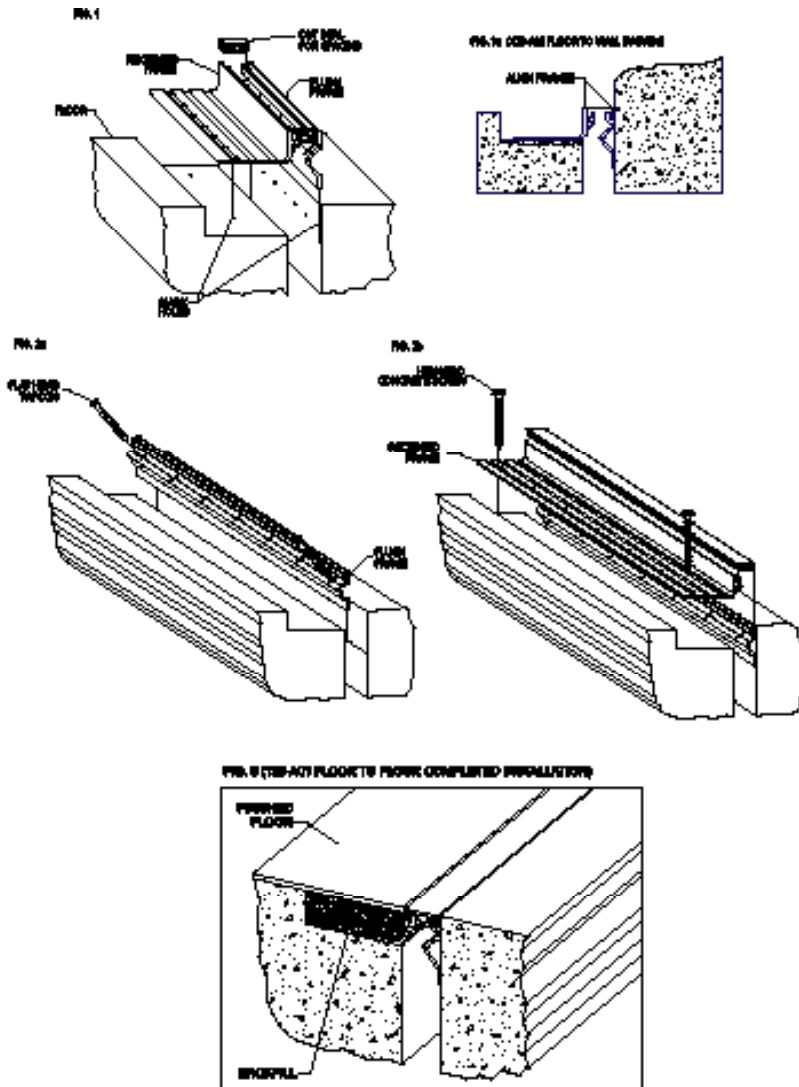

1. Install the architectural joint system on a level surface within the blackout. To determine blackout depth, deduct thickness of floor finish from frame height. Make sure top of frame is level with the finished floor height. This may require adding leveling compound to raise the tops of the frames. For floor to wall systems, align the recessed frame with the flush frame. See Fig. 1a.

See Fig. 1

2. Cut the aluminum frames to the desired length.
3. To properly space frames, cut three small 2" sections of seal. Insert one at each end and one in the center of each set of frames.
4. Center the frames over the structural gap, ensuring the frame bases do not extend over the gap.
5. Mark the pre-drilled hole locations on the substrate.
6. Remove the frame assembly from the blackout(s).
7. Drill holes for the flush frame using a 1/4" (6mm) drill bit to a 1 1/8" (30mm) depth. See Fig. 2a. Drill holes in the blackout using a 3/16" (5mm) concrete drill bit to 1 5/8" (42mm) depth. See Fig. 2b.
8. Return the frames into position over the drilled hole locations. Secure the flush frame in place using JK002 3/16" x 2 1/4" flat head tapcons. Secure the floor frames in place with JK001 1/4" x 1 1/2" hex head concrete screws for the recessed frame. Remove the temporary spacers.
9. Insert the Santoprene seal into the recessed frame slots and flush frame slots until the seal is flush with the tops of the frames.

**NOTE:** To assist in installing the seal, apply a mist of soapy water solution to the back of the seal. A 1" wide seam roller may be used to fully engage the seal ears into the frame slots.

10. Backfill the blackout and install the floor finish level to the top of the frame. Clean the exposed surfaces with a non-solvent cleaner, such as 409, as required. See Fig. 3.

ISO#IPC.803/Rev.1



### Installation Questions?

Contact our Installation Hotline 866.EZINPRO  
For Sales & Customer Service call 800.222.5556

**INPRO**  
**ENGINEERED**  
Metal Products