

# Installation Instructions

## Joint System: 1200

These instructions are intended as recommended guidelines. Due to the variability of field conditions, selection of the proper material for the intended application and installation are the sole responsibility of the applicator. The manufacturer's published installation procedures shall be followed at all times.

### Recommended Tools

Tape Measure Sharp, Knife, Miter Saw, Blue Painters Tape, Mineral Spirits, Clean Cloth, Isopropyl Alcohol, Caulking Tool, Wood Wedges.

### Material Sizing

1. Joints must be sized every 5-7 feet to ensure gap opening is uniform and depth is sufficient for the supplied material.

**NOTE:** Allow sufficient depth for the material to be recessed 1/8"-1/4" in the joint.

### Material Preparation

Tip: Material will expand faster when hot and slower when cold. In cold temperatures, store material in a heated area 24 hours prior to installation. In hot temperatures, store material out of direct sunlight and not in an enclosed storage container where temperatures may exceed 100°F.

1. Store material at a minimum of 68°F (20°C) for a minimum of 24 hours prior to installation, regardless of temperature at location of installation.

2. Store materials in a dry, enclosed area. Make sure materials are off the ground and out of direct sunlight.

3. Use a miter saw to make any cuts to the seal before removing the clear shrink packaging. All starting and ending pieces must be square to the termination point.

**NOTE:** Refer to the SEAMS section for further instructions on preparing the material for proper seam installation procedure.

Tip: Apply mineral spirits to the knife for a smoother cut.

**WARNING:** Install the material directly after removing the shrink packaging to ensure the material does not expand past the joint.

4. Use a sharp knife to make any cuts after the clear shrink packaging and wooden boards have been removed.

### Joint Preparation

1. Verify that the joint is clean, sound, and will provide an appropriate surface for installation of the joint sealant. Use compressed air to clean any loose debris from the joint. Apply water or alcohol to a clean cloth and wipe the joint walls to the depth of the sealant material plus 1".

2. Verify that the joint is uniform and repair any spalls prior to installation.

3. Apply blue painters tape to both edges of the substrate face to prevent the silicone from contacting the deck surface.

4. Check the material for appropriate length, width, and depth. Supplied material should be approximately 25% larger but never less than 12% larger than the intended joint opening. Joint depth must allow the installed material to be recessed 1/8"-1/4" from the joint face.

Fig 1

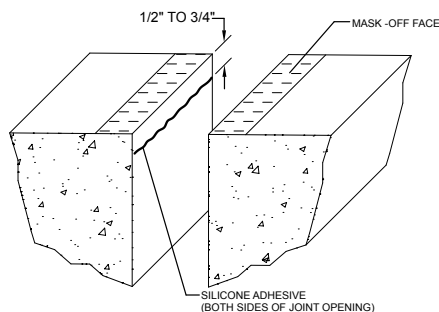

### Sealant Installation - See Fig. 1.

1. For joints that run horizontal, begin installing the material at one side of the joint (either side) and continue to install the material working towards the opposite end. For vertical joints, begin installation at the bottom of the joint and work upward. The installed sticks will support the subsequent sticks until the material fully expands.

**NOTE:** To ensure an aesthetic finish, verify that the silicone adhesive matches the color on the face of the joint sealant material.

2. Run a 1/4" bead of the supplied silicone adhesive along both joint walls approximately 1/2"-3/4" back from the surface of the joint substrate.

Note: When a continuous joint cannot be finished, the silicone on the substrate should stop at the last stick installed and silicone should not be applied to the end of the installed material until the next piece of material is ready to be installed.

IPC.930/Rev.1



### Installation Questions?

Contact our Installation Hotline 866.EZINPRO  
For Sales & Customer Service call 800.222.5556

**INPRO CORPORATION**  
Interior and Exterior Architectural Products

# Installation Instructions

## Joint System: 1200

Fig 2

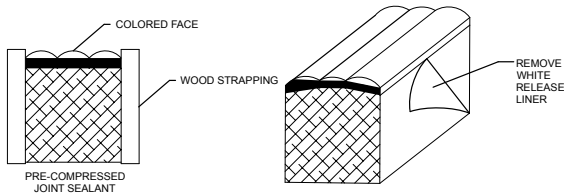

**See Fig. 2**

3. When fully prepared to install, open the sealant material by cutting the shrink packaging along the edge of the masonite strapping.

Warning: Do not cut the colored face of the material, and be prepared to install the material immediately once the packaging is removed to prevent the material from expanding past the joint width.

4. Verify that the material is cut square at both ends for proper seams. All pieces must be square to the termination point.

5. Remove the white release liner on both sides of the seal.

Warning: Do not twist or pull the material to avoid tearing the white release liner.

Fig 3

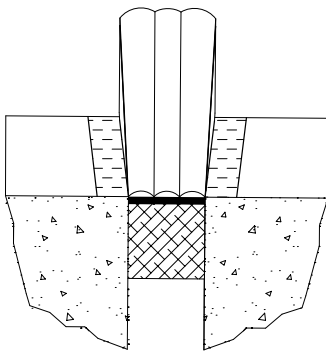

**See Fig. 3**

6. Place the material into the joint while gently pushing the pressure sensitive adhesive (PSA) up against the side of the joint. Once the material is in place, use a margin trowel to firmly press the adhesive to the substrate and allow the material to expand to fill the joint. Note: If the PSA is hampering installation, use a spray bottle to wet the adhesive surface of the seal (will not affect the final sealing properties). Installed material to be recessed 1/8"-1/4" from the joint face.

**See Fig. 4a**

**WARNING:** Allow 72 hours for full expansion and material equalization. Expansion and equalization rates are affected by temperature.

7. Silicone coating should be flush with, not protruding above, the substrate surface. **See Fig. 4b.**

Fig 4a

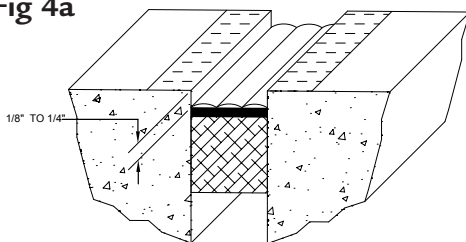
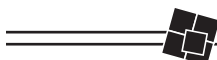
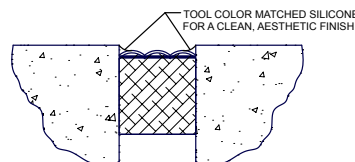

Fig 4b



**Installation Questions?**

Contact our Installation Hotline 866.EZINPRO  
For Sales & Customer Service call 800.222.5556

# Installation Instructions

## Joint System: 1200

---

Fig 5

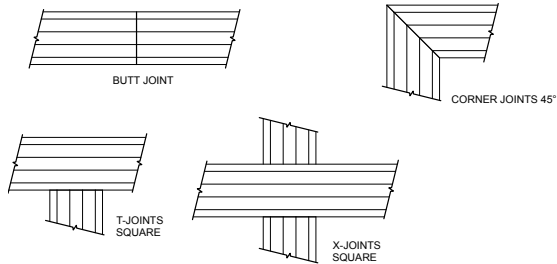

### Seams-See Fig. 5

1. Verify that the new piece of material is cut square and not at an angle to the previous material installed.
2. Apply silicone to the butt end of the new piece of material as well as a  $\frac{1}{4}$ " bead on both joint walls, inset  $\frac{1}{2}$ "- $\frac{3}{4}$ " as described in the Sealant Installation Section.
3. Overlap extra material (approximately  $\frac{1}{2}$ "-1") at seams and splices to ensure that the seam is in compression after installation.

### 4. "T" and "+" Intersections:

Install horizontal material first. Butt the vertical material up to the horizontal material following steps 1+2.

Note: After installation, if there are any mitered joints with a hole or a void, use the supplied silicone to fill and seal the joint.

5. Use the matching silicone to run a bead along each edge of the joint to fill any irregularities in the substrate.

Note: Seal does not require an external fillet bead to provide a watertight seal.

Fig 6

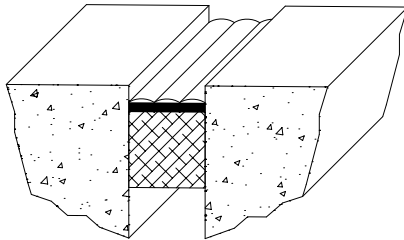

### Finish- See Fig. 6

1. Tool the silicone over all seams and transitions using a small caulking tool.
2. Evenly spread the silicone on exposed seams to allow for a clean, aesthetic finish.
3. Remove any excess silicone left on the surface of the material or substrate.

**WARNING:** Do not allow the silicone to cure before removal.

4. Remove the blue painters tape from the substrate surface.



### Installation Questions?

Contact our Installation Hotline 866.EZINPRO  
For Sales & Customer Service call 800.222.5556