

Installation Instructions

Joint System: 501-A01

Note: Verify that the structural gap and blockout dimensions are in conformance with submittal data. A secondary blockout or "undercut" is also required to accommodate +/- 100% movement. Check dimensions with submittal data before beginning installation. If this is a Fire Rated Assembly, the fire barrier must be installed before the Architectural Joint System. Refer to the fire barrier instructions for specific system installation.

Fig. 1 (501-A01 Floor to Floor shown)

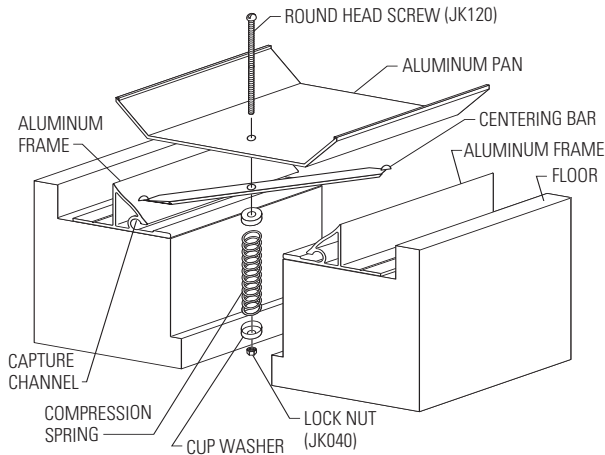

Fig. 2

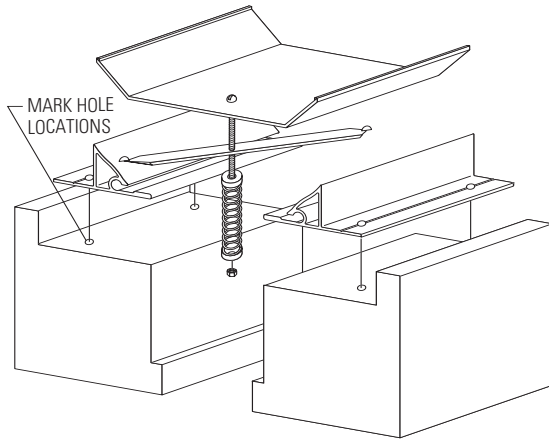
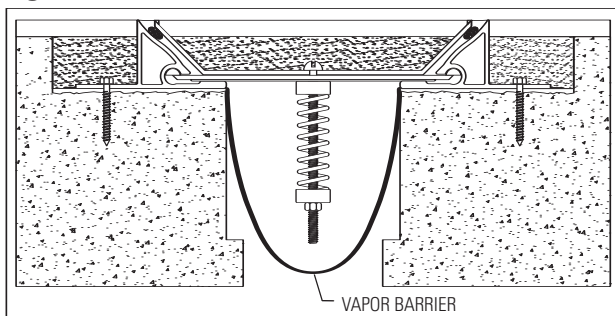

Fig. 2a



1. Install the architectural joint system on a level surface within the blockout. To determine blockout depth, deduct the thickness of the floor finish from the frame height. This may require adding leveling compound to raise the tops of the frames.

Figure 1

2. Cut the aluminum components to the desired length.
3. Place the frames on a level work surface so the sloped sides face one another.
4. Insert the centering bars diagonally into the capture channels of both frames with the rounded domes facing upward. Centering bars should be spaced approximately 18" on center starting 6" from each end.
5. Spread frames apart to allow for placement of the aluminum pan. The bottom of the pan should rest on top of the centering bars. Line up the holes in the pan with the holes in the centering bars beneath and insert one JK120 round head screw for each hole.
6. Assemble the compression springs by capping each end with a cup washer. JP500-1 spring kit included with 2", 3", 4" and 6" joint systems. JP500-2 included with 8" and wider joint systems.
7. Place the capped compression spring over each screw and secure with a JK040 lock nut. Hand tighten each nut so that the spring is compressed approximately 5-10%.

Figure 2

8. Place the assembled system in the blockout so that it is centered over the structural gap. The aluminum frames should not extend over the edge of the structural gap. Adjust the joint system width to allow a 1/2" (13mm) space between the top point of the frame and the outermost edge of the pan on both sides.
9. Mark the pre-drilled hole locations on the substrates and remove the system from the blockout. Drill all marked holes in the blockout using a 3/16" (5mm) concrete drill bit to 1 5/8" (42mm) depth.
 - 9a. Optional EPDM Vapor Barrier: Lay continuous bead of butyl rubber caulk in both sides of the blockout. Starting at one end of the frame assembly, place vapor barrier evenly in the blockout allowing the excess material to drape into the structural gap. If necessary, vapor barrier may be fastened to substrate with masonry nails. Fold ends up or weep out (see Figure 2a).

Installation Instructions

Joint System: 501-A01

Fig. 3

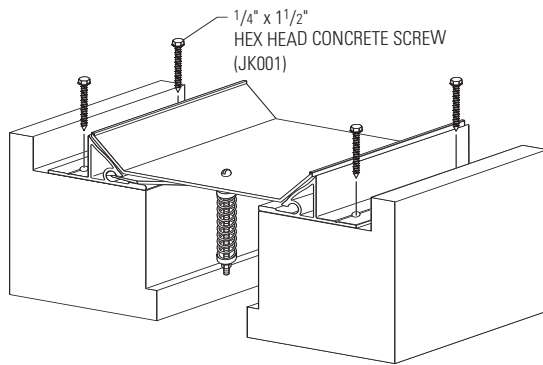

Fig. 4 (501-A01 completed installation)

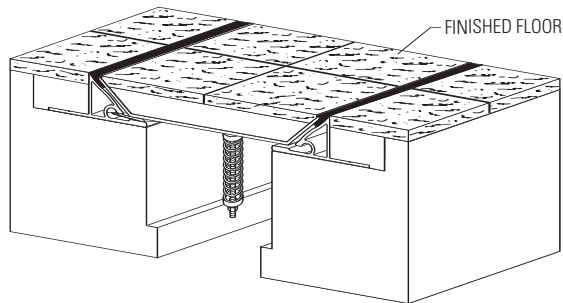

Figure 3

10. Return the assembled system over the structural gap so the pre-drilled frame holes line up over the drilled hole locations in the substrate. Secure the frames in place with JK001 1/4" x 1 1/2" hex head concrete screws.

Figure 4

11. Backfill the blockout with high strength non-shrink epoxy grout (installer furnished). Install the floor finish level to the top of the frames and in the pan.
12. Insert backer rod (installer furnished) into 1/2" (13mm) space between both frames and pan to 1/4" (6mm) depth below the top of the frame. Install the sealant (installer furnished) per the manufacturer's recommended instructions.
13. Clean the exposed surfaces with a non-solvent cleaner, such as 409, as required.