

501 Series

A01 - Floor to Floor

A02 - Floor to Wall

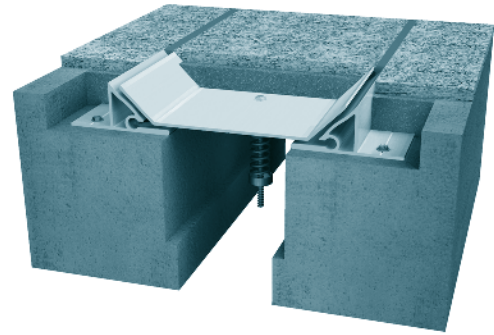

Movement Rating ± 100%

Product Guide



- ▶ Ideal system for use with high grade marble, granite, limestone and paver floor/wallfinishes
- ▶ “Zero sightline” favored by interior designers
- ▶ Centering bar/compression spring assembly correctly repositions pan-after system movement
- ▶ Integrated floor and wall system
- ▶ Easy onsite assembly and installation
- ▶ Load rated

Application	System	W		H1		H2		S		B		Movement +/-				Load	
		Joint Width		Frame Height 1		Height 2		Sight Line		Blockout		Horizontal		Vertical		US ton	kN
		US	mm	US	mm	US	mm	US	mm	US	mm	US	mm	US	mm		
Floor/Floor	501-A01-050	2"	51	2"	51	1 1/2"	38	8 1/8"	206	5"	127	4 3/8"	110	2"	6	2.8	25
	501-A01-075	3"	76	2"	51	1 1/2"	38	9 1/8"	231	5"	127	4 3/8"	110	3"	13	1.7	15
	501-A01-100	4"	102	2"	51	1 1/2"	38	10 1/8"	257	5"	127	4 3/8"	110	4"	19	HP	HP
	501-A01-150	6"	152	2"	51	1 1/2"	38	12 1/8"	308	5"	127	4 3/8"	110	6"	25	HP	HP
	501-A01-200	8"	203	2"	51	1 1/2"	38	14 1/8"	359	5"	127	7 1/2"	191	8"	38	HP	HP
Floor/Wall	501-A02-050	2"	51	2"	51	1 1/2"	38	8 1/8"	206	5"	127	4 3/8"	110	2"	6	2.8	25
	501-A02-075	3"	76	2"	51	1 1/2"	38	9 1/8"	231	5"	127	4 3/8"	110	3"	13	1.7	15
	501-A02-100	4"	102	2"	51	1 1/2"	38	10 1/8"	257	5"	127	4 3/8"	110	4"	19	HP	HP
	501-A02-150	6"	152	2"	51	1 1/2"	38	12 1/8"	308	5"	127	7 1/2"	191	6"	25	HP	HP
	501-A02-200	8"	203	2"	51	1 1/2"	38	16 1/8"	409	5"	127	7 1/2"	191	8"	38	HP	HP

A07/A09 condition dimensions/movement same as A01/A02 condition.

NOTE: 501-A01 Series width of undercut is consistent at 1/2" (13mm) and is designed for ± 100% movement.

501-A02 Series width of undercut is consistent at 3/8" (99mm) and is designed for ± 100% movement.

IPC.855/REV.4

501 Series “Pop-Up” Seismic Floor and Wall Systems

501-A01 Floor/Floor
(4” (100mm) system shown)

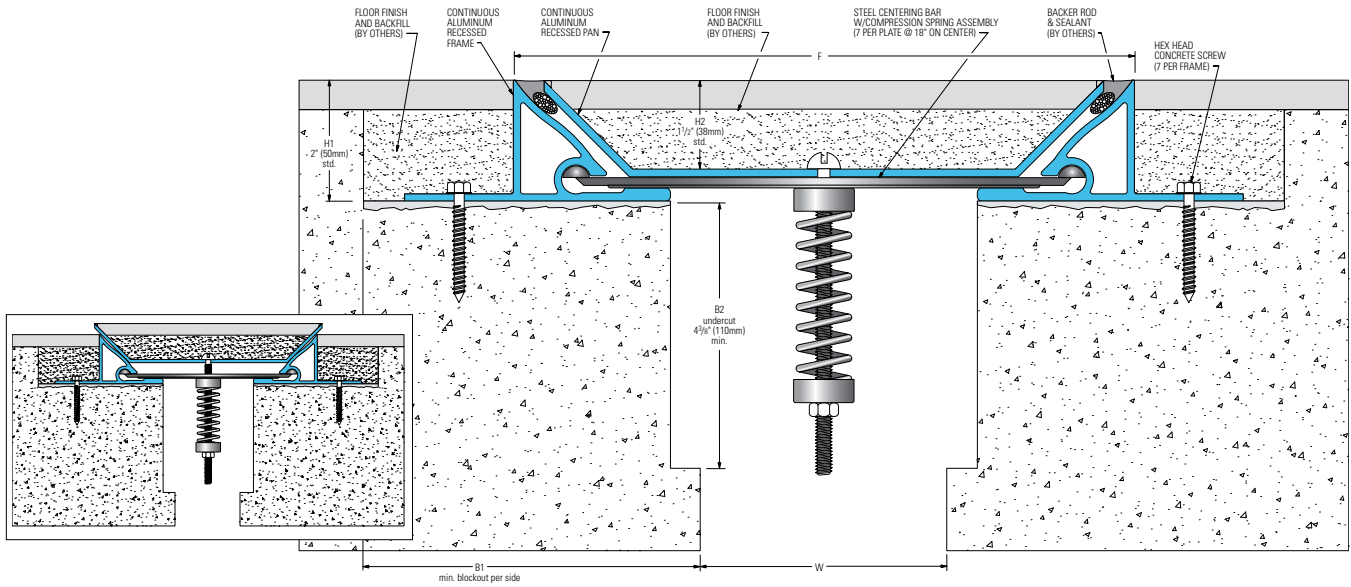

501-A02 Floor/Wall
(4” (100mm) system shown)

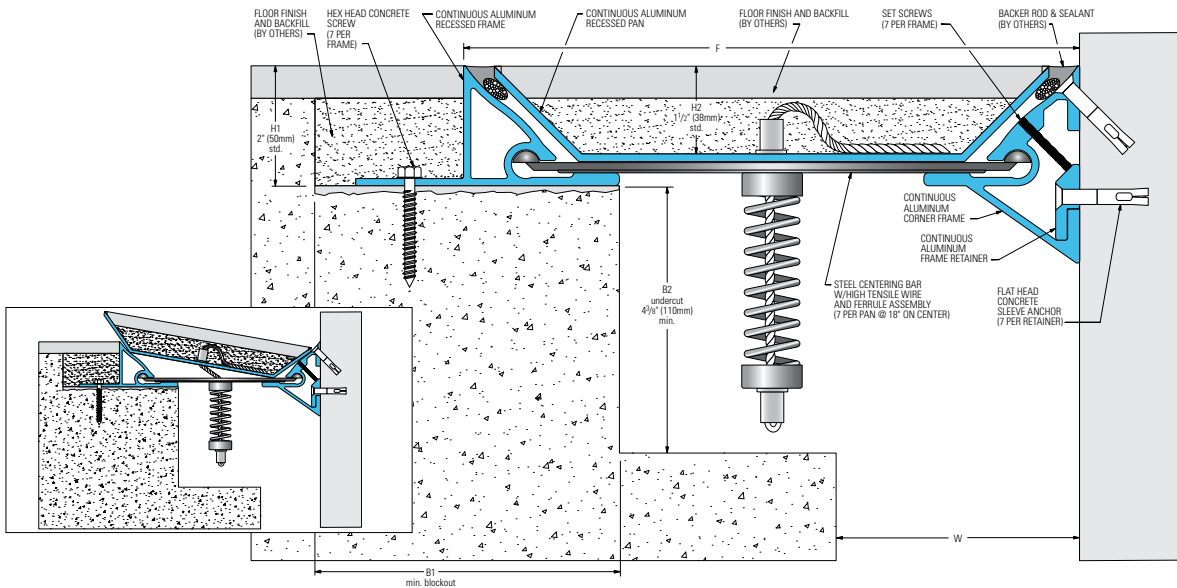

P.O. Box 406 · Muskego, Wisconsin 53150 USA

www.inprocorp.com

Nationwide 800.222.5556 / Fax 888.715.8407

International Sales 262.679.5521 / Fax 262.679.5524

501 Series Options

Reactofire Fire Blanket System (501-A01-100 system shown)

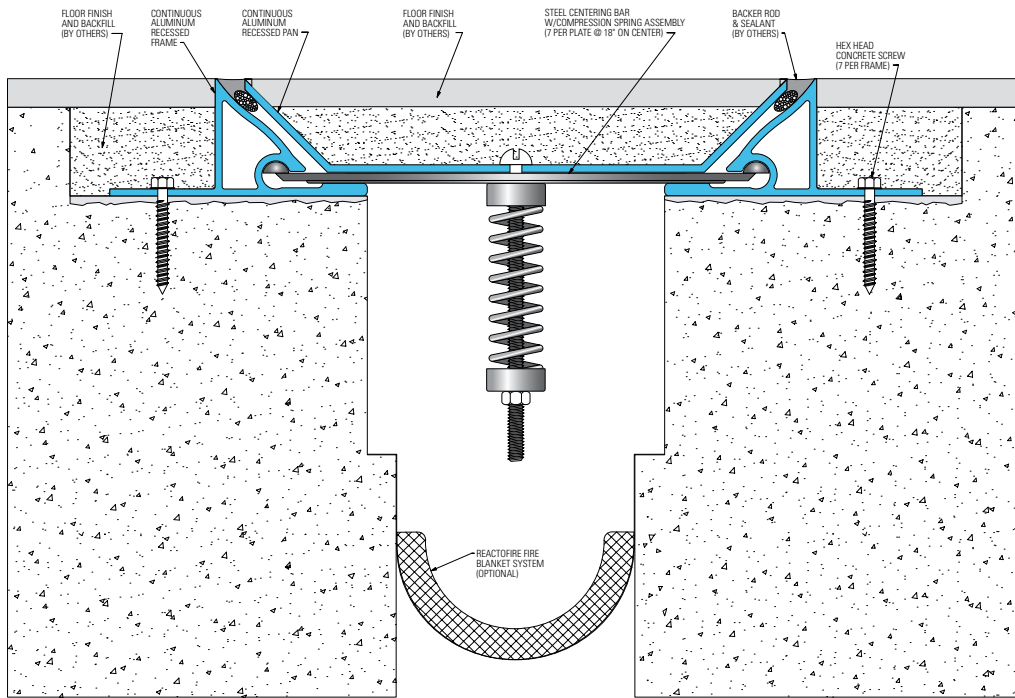

Wrap Around Vapor Barrier (501-A01-100 system shown)

