

Installation Instructions

Joint System: 615-A07 / A09-050 / 075 / 100 / 150

Note: verify that the structural gap (joint opening) is constructed in conformance with submittal data before beginning installation. In general, this means that (a.) the J.O. is sized properly for the corresponding temperature as shown in the bid documents, (b.) the J.O. is consistent in width along the entire length of the joint and (c.) the J.O. has no abrupt "steps" mandating field correction and action. If this is a fire rated assembly, the fire barrier system must be installed before the architectural joint system. Refer to the fire barrier instructions for specific system installation.

FIG. 1 (615-A07 WALL TO WALL)

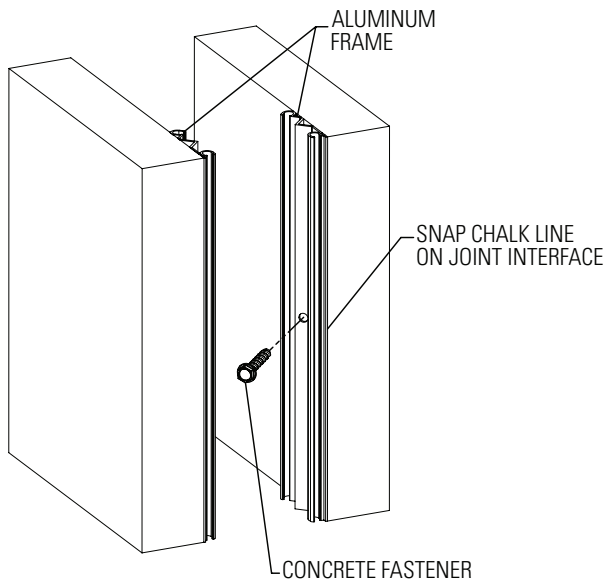

FIG. 2

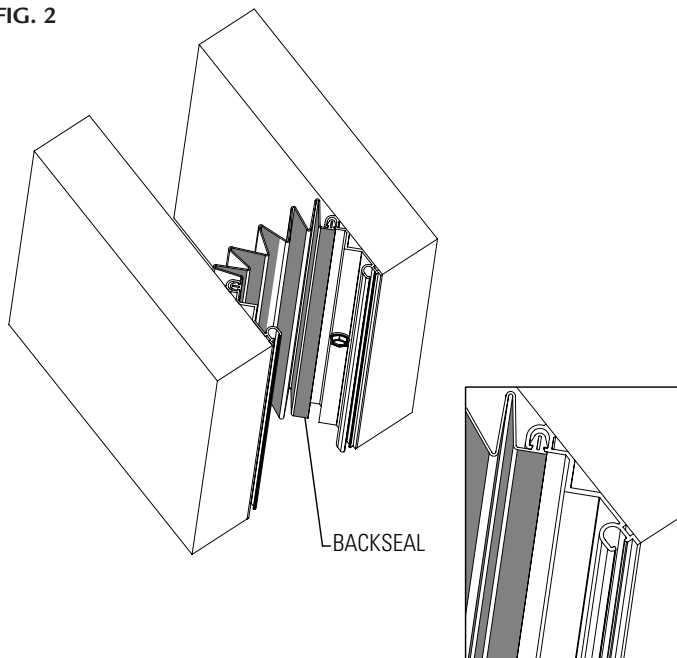

Figure 1

1. Snap a chalk line on the joint interfaces. This will be used later to position the side frames for the entire height of the wall. Installing contractor must fix any irregularities in the substrate walls prior to the installation of the systems.
2. Beginning at the base of the wall, set the side frames in a continuous bead of an appropriate sealant adhesive (as approved by the architect and supplied by the installer) and fasten to the substrate using the hardware supplied by InPro.
3. For joints exceeding 10 feet in length, repeat steps one and two going up the wall. At the top of the wall, trim lengths as required to adjust to top of wall conditions and/or mate with roof joint products.

Figure 2

4. Measure the wall height and cut the back seal to length, making it slightly longer than required. Install seal in one continuous piece. Starting at the top of the joint, insert the seal lugs into the frame receptacles. Fantastic or soapy water will help with the insertion.
5. Trim excess length of the back seal at the base of the wall.

Note: Extend the back seal to the ground, keeping it longer than the visual face seal. This will allow for moisture trapped between the seals to escape.



Installation Questions?

Contact our Installation Hotline 866.EZINPRO
For Sales & Customer Service call 800.222.5556

Installation Instructions

Joint System: 615-A07 / A09-050 / 075 / 100 / 150

Note: verify that the structural gap (joint opening) is constructed in conformance with submittal data before beginning installation. In general, this means that (a.) the J.O. is sized properly for the corresponding temperature as shown in the bid documents, (b.) the J.O. is consistent in width along the entire length of the joint and (c.) the J.O. has no abrupt "steps" mandating field correction and action. If this is a fire rated assembly, the fire barrier system must be installed before the architectural joint system. Refer to the fire barrier instructions for specific system installation.

FIG. 3

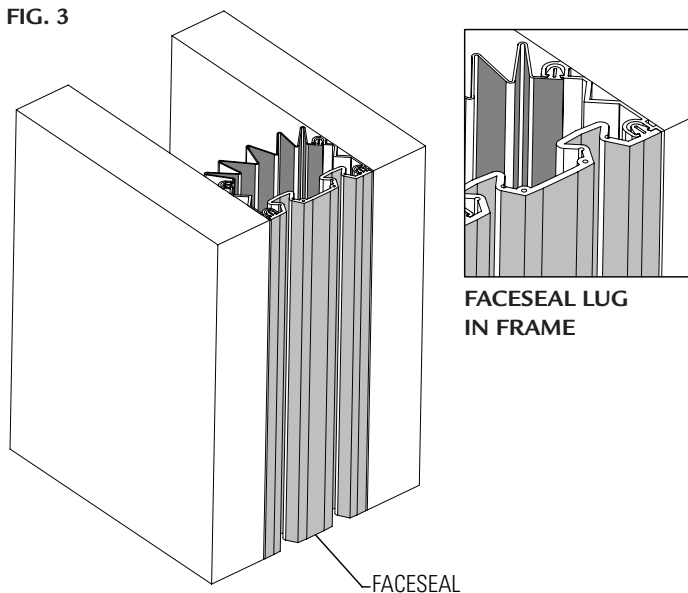

Figure 3

6. Cut the face seal to a length slightly longer than required. Install the face seal as a continuous piece. Starting at the top of the joint, push the seal lugs into the frame receptacles. Fantastic or soapy water will help with the insertion.
7. Trim the excess length at the base of the wall.
Note: The face seal should be 1" shorter than the back seal. This will allow any moisture trapped between the seals to escape.
8. Depending upon the project requirements, a continuous bead of caulk (by others) may be required to be installed where the outside edge of the face seal abut the substrate walls

Figure 4

9. Per project dictates, address details at the top of the wall where the system meets with the expansion joint on the roof or roof parapet. This transition area, and components, should be shown in InPro Shop Drawing details. If none are shown, please contact InPro for appropriate details.
Note: for inside corners or restricted gap access, frames may be secured in place with contractor furnished epoxy adhesive instead of mechanical fasteners.

FIG. 4 (615-A07 WALL TO WALL)

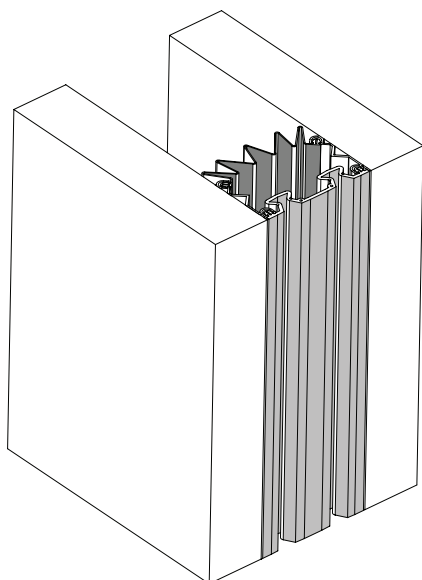

Installation Questions?

Contact our Installation Hotline 866.EZINPRO
For Sales & Customer Service call 800.222.5556

INPRO CORPORATION
Interior and Exterior Architectural Products