

# Installation Instructions

## Joint System: 651-A07

**Note:** Verify that the structural gap is in conformance with submittal data before beginning installation. If this is a Fire Rated Assembly, install the fire barrier before the Architectural Joint System. Refer to the fire barrier instructions for specific system installation.

**Fig. 1**

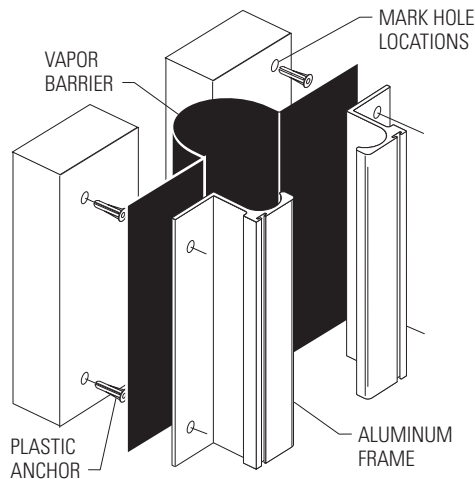

1. Install the architectural joint system on a level wall surface. This may require leveling to raise the tops of the frames.

**Figure 1**

2. Cut the aluminum components to the desired length.
3. Center the wall frames over the structural gap. The radius profile of the frames should be facing the structural gap. Align plumb.
4. To properly space frames, use the chart below to determine the distance between the opposing outside faces of the frames:

Joint Width		Frame to Frame	
US	MM	US	MM
1"	25	3/4"	19
2"	50	1 1/2"	38
3"	75	2 1/2"	64
4"	100	3 1/2"	89
6"	150	5 1/2"	140
8"	200	7 1/2"	191
10"	250	9 1/2"	242
12"	300	11 1/2"	292

5. Mark the pre-drilled hole locations on the substrate and remove the frames from the wall.
6. Drill all marked holes on the wall using a 1/4" (6mm) drill bit to 1 1/2" (38mm) depth. Insert plastic plug anchors.
7. Lay continuous bead of butyl caulk (contractor furnished) on face of walls. Starting from the top of the joint opening, place vapor barrier evenly over wall substrate allowing the excess material to drape into the structural gap. If necessary, vapor barrier may be fastened to substrate with nails. Fold ends up or weep out (See Figure 1a).

IPC.860/REV.2



### Installation Questions?

Contact our Installation Hotline 866.EZINPRO  
For Sales & Customer Service call 800.222.5556

**INPRO CORPORATION**  
Interior and Exterior Architectural Products

# Installation Instructions

## Joint System: 651-A07

Fig. 2

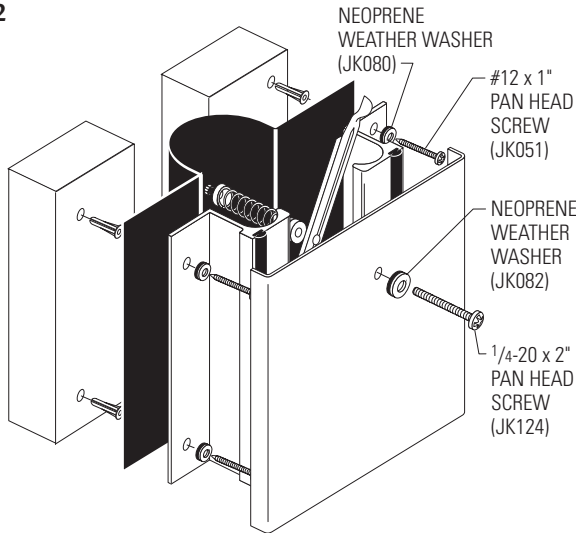

Fig. 3

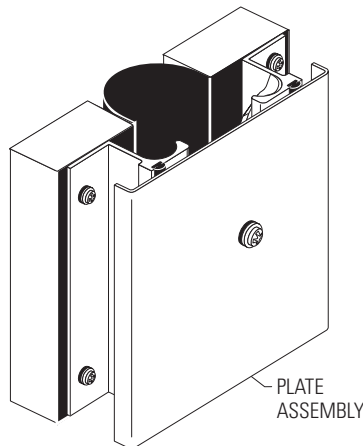

Fig. 4

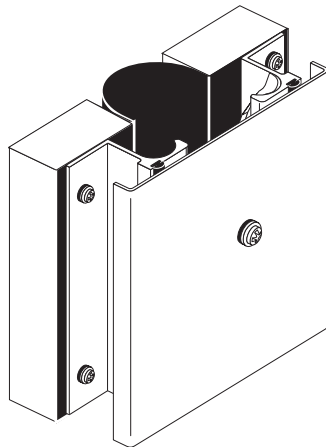

Figure 2

8. Return the frames into position over the drilled hole locations. Secure in place with one JK051 #12 x 1" pan head screw through a JK080 neoprene weather washer for each plastic plug.
9. Slide the vinyl gasket into the frame's dart receptacle.
10. Assemble the plate by inserting one JK124 1/4-20x2" pan head screw through a JK082 neoprene weather washer for each counter-sunk hole in the aluminum plate. Loosely thread one centering bar on each screw with the rounded domes facing the plate. Centering bars should be aligned diagonally and parallel to each other.

Figure 3

11. Place the plate assembly centered over the frames. Tighten the screws to engage the centering bars in the frame channels.

Figure 4

12. Clean exposed surfaces with a non-solvent cleaner, such as 409, as required.

### Installation Questions?

Contact our Installation Hotline 866.EZINPRO  
For Sales & Customer Service call 800.222.5556