

Installation Instructions

700i/700iW/G700i Wall Guard

Please read all instructions before installing wall guard.

FIG. 1

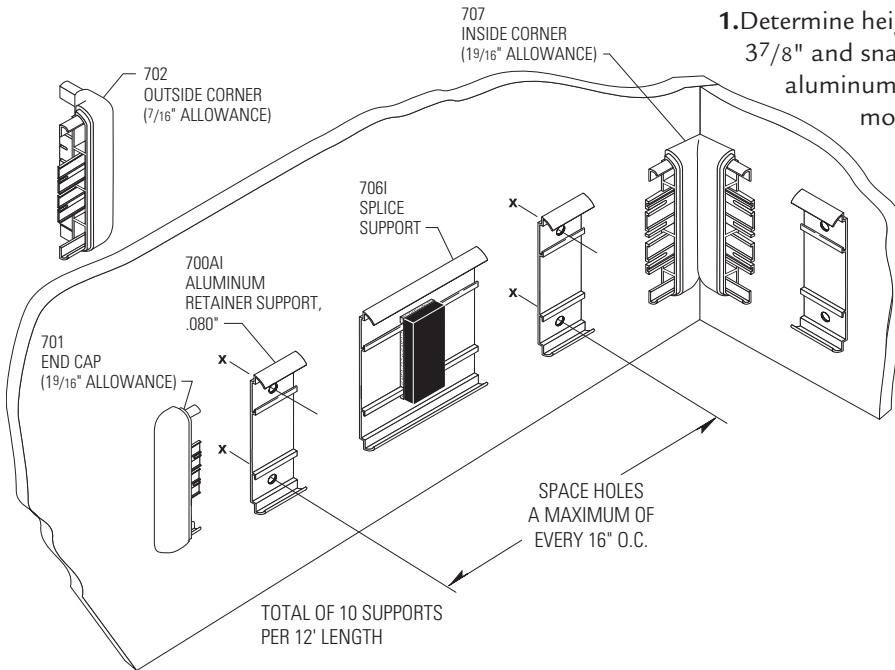

1. Determine height of wall guard on wall. Measure down $3\frac{7}{8}$ " and snap chalk line. Position the centerline of the aluminum retainer support on the chalk line to mark mounting holes leaving allowance for returns, outside corners and inside corners. See Figure 1.

FIG. 2

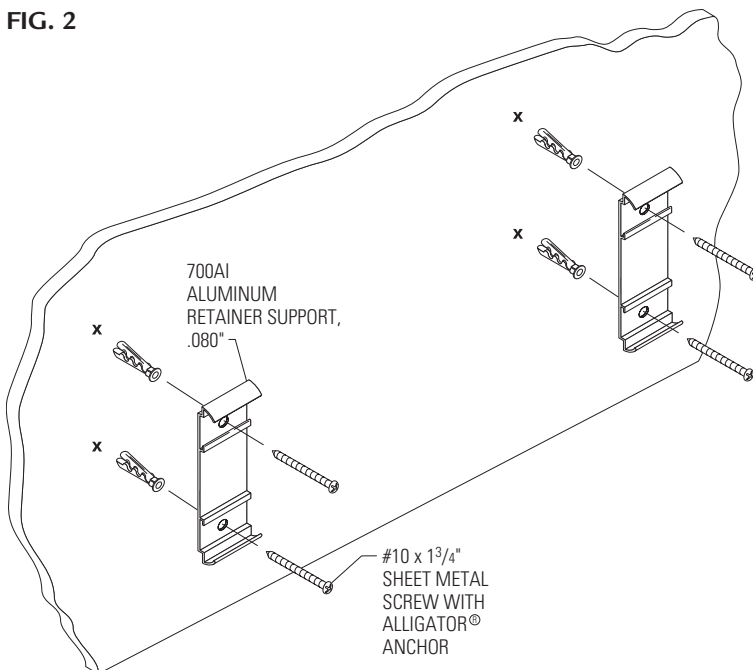

2. Drill marked holes on wall using a $\frac{1}{4}$ " drill bit and position Alligator anchors into holes. Mount retainer supports on wall and tighten screws to secure. See Figure 2.

With lengths over 12', a splice is recommended between vinyl butt joints for added support. See Figure 2a.

NOTE: For concrete or brick wall installation, drill $\frac{1}{4}$ " holes, $\frac{3}{8}$ " from end of retainer for end caps/corners.

FIG. 2A

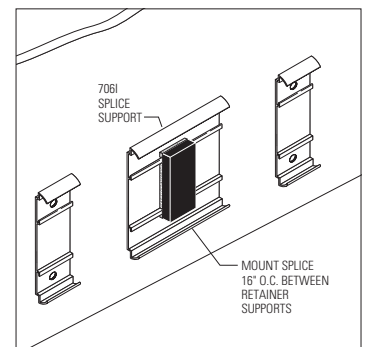

IPC.361/REV.3

Installation Questions?

Contact our Installation Hotline 866.EZINPRO
For Sales & Customer Service call 800.222.5556

INPRO
IPC Interior Protection Products
and Decorative Surfaces

Installation Instructions

700i/700iW/G700i Wall Guard

FIG. 3

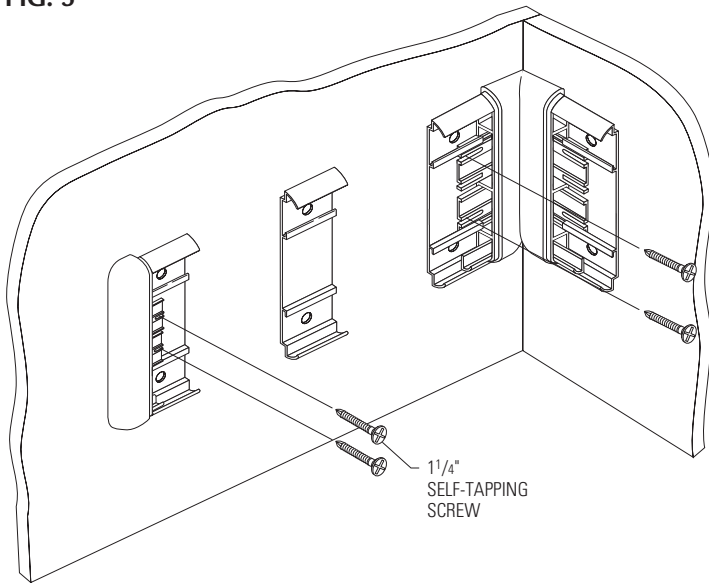

- Slide end caps and corners onto the retainer support and secure, leaving a $\frac{1}{16}$ " gap between returns/corners and retainer to allow for adjustment. See Figure 3.

NOTE: For concrete or brick wall installation, use #10 x $1\frac{3}{4}$ " Phillips pan head screws to secure retainer to the wall.

FIG. 4

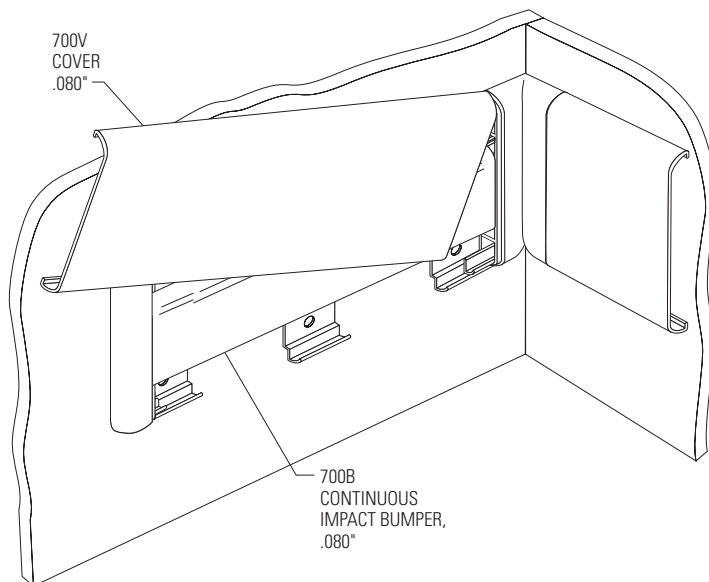

- Cut the impact bumper to the length between the inside edge of the end caps/corners/splice. Position and snap bumper in place. Cut the cover to length between end caps and/or corners. (Note: Trim factory edges square before installation). Position cover on retainer and adjust returns and/or corners for a tight fit. Starting at one end of retainer supports, push cover over the retainer supports until it snaps into place. See Figure 4.



Installation Questions?

Contact our Installation Hotline 866.EZINPRO
For Sales & Customer Service call 800.222.5556

INPRO CORPORATION
Interior and Exterior Architectural Products