

700i/700iW Wall Guards

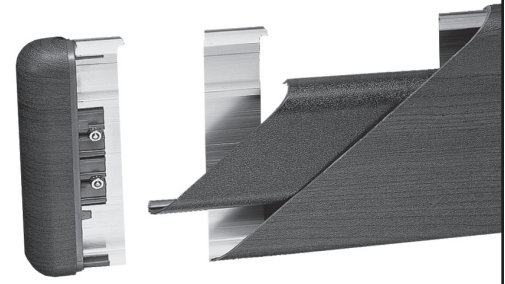

700i



700iW

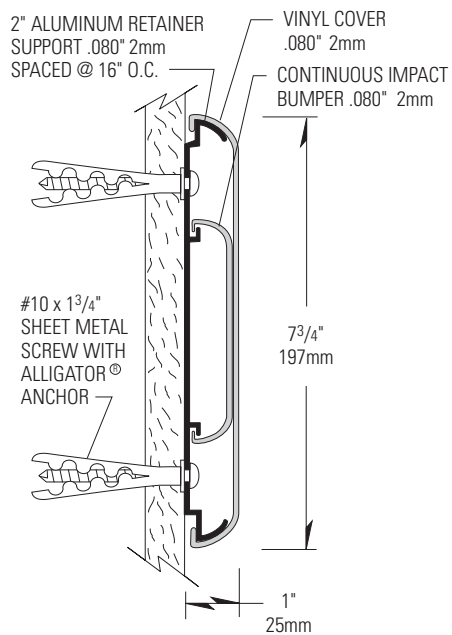

- ▶ 7³/₄" (197mm) of wall protection, extends 1" (25mm) from wall
- ▶ Mounted on an abbreviated aluminum retainer
- ▶ .080" (2mm) thick, scratch and stain resistant rigid vinyl cover
- ▶ Easy installation, clean-up and maintenance
- ▶ Manufactured in 12' (3.66m) standard lengths
- ▶ All mounting fasteners are included with each order
- ▶ 700iW Model - Manufactured with Woodland pattern full wrap
- ▶ Meet immediate needs with InPro's Quick Ship program for the 700i wall guard

IPC.360/REV.7



P.O. Box 406 · Muskego, Wisconsin 53150 USA
inprocorp.com
Nationwide 800.222.5556/Fax 888.715.8407
International Sales 262.679.5521/Fax 262.679.5524

INPRO
IPC Interior Protection Products
and Decorative Surfaces

700i/700iW Wall Guards

Suggested Specifications

PART 1 – GENERAL

1.01 SUMMARY

A. Wall guard system for wall protection and decoration

1.02 SECTION INCLUDES:

A. 700i/700iW Infinity System Wall Guards

1.03 REFERENCES

- A. American Society for Testing and Materials (ASTM)
- B. National Building Code of Canada (NBC)
- C. National Fire Protection Association (NFPA)
- D. Society of Automotive Engineers (SAE)
- E. Underwriters Laboratory (UL)
- F. Underwriters Laboratory of Canada (ULC)
- G. Uniform Building Code (UBC)

1.04 SYSTEM DESCRIPTION

A. Performance requirements: Provide wall guard systems that conform to the following requirements of regulatory agencies and the quality control of IPC Door and Wall Protection Systems, InPro Corporation.

1. Fire Performance Characteristics: Provide UL Classified wall guards conforming with NFPA Class A fire rating. Surface burning characteristics, as determined by UL-723 (ASTM E-84), shall be flame spread of 10 and smoke development of 350 - 450. Provide ULC (Canada) listed wall guards conforming to the requirements of the National Building Code of Canada 1990, Subsection 3.1.13. Surface burning characteristics, as determined by CAN/ULC-S102.2, shall be flame spread of 15 and smoke developed of 35.
2. Self Extinguishing: Provide wall guards with a CC1 classification, as tested in accordance with the procedures specified in ASTM D-635-74, Standard Test Method for Rate of Burning and/or Extent and Time of Burning of Self-Supporting Plastics in a Horizontal Position, as referenced in UBC 52-4-1988.
3. Impact Strength: Provide rigid vinyl profile materials that have an Impact Strength of 30.2 ft-lbs/inch of thickness as tested in accordance with the procedures specified in ASTM D-256-90b, Impact Resistance of Plastics.
4. System Impact Resistance: Provide a wall guard system that resists an impact of 175.9 ft-lbs while producing no visual blemishes upon the vinyl cover surface and no deformations in the aluminum retainers, as tested in accordance with applicable provisions of ASTM F 476-84, paragraph 18, Impact Test.
5. Chemical and Stain Resistance: Provide wall guards that show resistance to stain when tested in accordance with applicable provisions of ASTM D-543.
6. Fungal and Bacterial Resistance: Provide rigid vinyl that does not support fungal or bacterial growth as tested in accordance with ASTM G-21 and ASTM G-22.
7. Color Consistency: Provide components matched in accordance with SAE J-1545 - (Delta E) with a color difference no greater than 1.0 units using CIE Lab, CIE CMC, CIE Lch, Hunter Lab or similar color space scale systems.

1.05 SUBMITTALS

- A. Product Data: Manufacturer's printed product data for each type of wall guard specified.
- B. Detail Drawings: Mounting details with the appropriate fasteners for specific project substrates.
- C. Samples: Verification samples of wall guard, 8" (203mm) long, in full size profiles of each type and color indicated.
- D. Manufacturer's Installation Instruction: Printed installation instructions for each wall guard.

1.06 DELIVERY, STORAGE AND HANDLING

- A. Deliver materials in unopened factory packaging to the jobsite
- B. Inspect materials at delivery to assure that specified products have been received.
- C. Store in original packaging in a climate controlled location away from direct sunlight.

1.07 PROJECT CONDITIONS

- A. Environmental Requirements: Products must be installed in an interior climate controlled environment.

1.08 WARRANTY

- A. Standard IPC Limited Lifetime Warranty against material and manufacturing defects.

PART 2 – PRODUCTS

2.01 MANUFACTURER

- A. Acceptable Manufacturer:
IPC Door and Wall Protection Systems, InPro Corporation, PO Box 406 Muskego, WI 53150 USA; Telephone: 800-222-5556, Fax: 888-715-8407, www.inprocorp.com
- B. Substitutions: Not permitted
- C. Provide all wall guards and wall protection from a single source.

2.02 MANUFACTURED UNITS

- A. Wall Guard Profile
 1. 700i Infinity System Wall Guard, 7³/₄" (197mm) height x 1" (25mm) depth, with abbreviated aluminum retainer
 2. 700iW Infinity System Wall Guard, 7³/₄" (197mm) height x 1" (25mm) depth, with abbreviated aluminum retainer. Wall guard has a full wrap woodgrain pattern.

2.03 MATERIALS

- A. Vinyl: Snap-on covers of .080" (2mm) thickness shall be extruded from chemical and stain resistant polyvinyl chloride with the addition of impact modifiers. No plasticizers shall be added (plasticizers may aid in bacterial growth).
- B. Aluminum: 2" aluminum retainer supports for 700i Infinity System of .080" (2mm) thickness shall be fabricated from 6063-T5 aluminum, with a mill finish.

2.04 COMPONENTS

- A. End caps, inside corners and outside corners shall be made of injection molded thermoplastics.
- B. Fasteners: All mounting systems accessories appropriate for substrates indicated on the drawings shall be provided.

2.05 FINISHES

- A. Vinyl Covers: Color of the wall guard to be selected by the architect from the IPC finish selection. Surface shall have a pebblette texture.

- B. Molded Components: End caps, inside corners and outside corners shall be of a color matching the wall guards. Surface shall have a pebblette texture.

PART 3 – EXECUTION

3.01 EXAMINATION

A. Examine areas and conditions in which the wall guard will be installed.

1. Complete all finishing operations, including painting, before beginning installation of wall guard materials.
- B. Wall surface shall be dry and free from dirt, grease and loose paint.

3.02 PREPARATION

A. General: Prior to installation, clean substrate to remove dust, debris and loose particles.

3.03 INSTALLATION

- A. General: Locate wall guard as indicated on the approved detail drawing for the appropriate substrate and in compliance with the IPC installation instructions. Install wall guard level and plumb at the height indicated on the drawings.
 - B. Installation of 700i Infinity System Wall Guards:
 1. Determine the height of the top of the wall guard above the finished floor. Deduct 3⁷/₈" and snap a chalk line.
 2. Ten aluminum retainer supports per 12' (3.66m) length, spaced 16" (406mm) on center are recommended. Position the centerline of a 2" (51mm) aluminum retainer support on the chalk line. Start at one end, using an aluminum support as a template, transfer the locations of the two holes on each aluminum retainer support to the wall with a marker. At the beginning and end of each run allow 1⁹/₁₆" (40mm) for end caps, 7¹/₁₆" (11mm) for outside corners and 1⁹/₁₆" (40mm) for inside corners. Add approximately 1¹/₁₆" space between the end caps/corners and the aluminum retainer support in order to allow for adjustments when attaching the vinyl cover.
 3. Secure aluminum retainer supports to the wall using hardware provided (2 fasteners per support). When installing continuous lengths over 12' (3.66m), use a splice behind the vinyl cover seam.
 4. Drill all marked holes on the wall with a 1/4" drill bit. Position ALLIGATOR anchors into the holes on the wall and use #10 x 1³/₄" phillips pan head screw to attach each aluminum retainer support to the wall. Level and tighten the aluminum retainer supports to the wall.
 5. Slide the end caps and corners onto the aluminum supports, leaving a 1¹/₁₆" gap for adjustments, and secure by using two 1¹/₄" self-tapping screws per end cap or four per corner.
 6. Cut the vinyl cover to the distance between the end caps/corners. NOTE: Trim all factory edges square before installation. Position the vinyl cover on the aluminum retainer supports starting at one end and working to the other end by pushing the cover over the aluminum until it snaps into place.
- #### 3.04 CLEANING
- A. At completion of the installation, clean surfaces in accordance with the IPC clean-up and maintenance instructions.

