

CR1 Wood/Bamboo Chair Rail

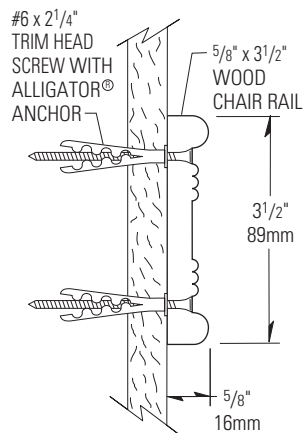

- ▶ 3 1/2" (88mm) height, extends 5/8" (16mm) from the wall
- ▶ Simple chair rail design evokes old-fashioned comfort with clean, crisp styling
- ▶ Combine with HR1 Wood/Bamboo Handrail for a classic combination
- ▶ Suited for elegant applications in low abuse areas
- ▶ Available in red oak, maple wood or bamboo
- ▶ Easy installation, clean-up and maintenance
- ▶ Manufactured in 8' - 16' (2.44m - 4.88m) random lengths
- ▶ All mounting fasteners are included with each order

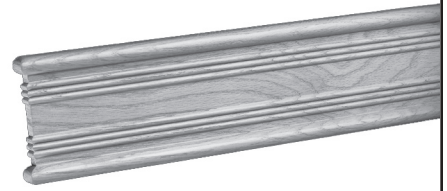

IPC.309/REV.5

P.O. Box 406 · Muskego, Wisconsin 53150 USA
inprocorp.com
Nationwide 800.222.5556/Fax 888.715.8407
International Sales 262.679.5521/Fax 262.679.5524

INPRO
IPC Interior Protection Products
and Decorative Surfaces

CR1 Wood/Bamboo Chair Rail

Suggested Specifications

PART 1 GENERAL

1.01 SUMMARY

A. Chair rail systems for wall protection

1.02 SECTIONS INCLUDES

A. Northern Hardwoods CR1 Chair Rail. Solid wood chair rail in red oak.

B. Northern Hardwoods CR1 Chair Rail. Solid wood chair rail in maple.

C. Northern Hardwoods CR1 Chair Rail. Solid bamboo chair rail.

1.03 REFERENCES

A. American National Standards Institute (ANSI)

B. Environmental Protection Agency (EPA)

C. Kitchen Cabinets Manufacturers Association (KCMA)

D. National Emission Standards for Hazardous Air Pollutants (NESHAP)

1.04 SYSTEM DESCRIPTION

A. Performance Requirements: Provide wood chair rail systems that conform to the following requirements of regulatory agencies and the quality control of IPC Door and Wall Protection Systems, InPro Corporation.

1. Cold, heat and chemical resistance: Provide wood Chair Rail with a finish that complies with the applicable provisions of ANSI/KCMA A161.1-1990 for cold check, heat and chemical resistance.

2. Environmental compliance: Provide wood chair rail and with a finish that does not off gas or emit any VOC, after a full cure, as tested in accordance to the EPA, NESHAP, Method 24, 40CFR, Volume 60, Appendix A.

1.05 SUBMITTALS

A. Product Data: Manufacturer's printed product data for each product indicated in this section.

B. Detail Drawings: Mounting details with appropriate fasteners for specific project substrates.

C. Loaner Samples: Verification samples of chair rail, 15" (381mm) long, in full size profiles with one end cap of each type and color indicated. Return samples to IPC after review.

D. Manufacturer's Installation Instructions: Printed installation instructions for each chair rail.

1.06 DELIVERY, STORAGE AND HANDLING

A. Deliver materials in unopened factory packaging to the jobsite.

B. Inspect materials at delivery to assure that specified products have been received.

C. Store in original packaging in a climate controlled environment away from direct sunlight.

1.07 WARRANTY

A. Standard IPC Limited Lifetime Warranty against material and manufacturing defects.

PART 2 PRODUCTS

2.01 MANUFACTURERS

A. Acceptable Manufacturer: IPC Door and Wall Protection Systems, InPro Corporation, PO Box 406, Muskego, WI 53150 USA; Telephone 800.222.5556, Fax: 888.715.8407, www.inprocorp.com

B. Substitutions: Not permitted

C. Provide all chair rails and wall protection from a single manufacturer.

2.02 MANUFACTURED UNITS

A. Wood Chair Rail

1. CR1 Chair Rail, 3¹/₂" (89mm) height, and extends ⁵/₈" (16mm) from the wall.

2.03 MATERIALS

A. Wood: Shall be FAS grade, kiln dried, solid maple or red oak with moisture content of 5-9%.

B. Bamboo: Shall be 100% bamboo, kiln dried, with a moisture content of 7-10%.

2.04 COMPONENTS

A. End cap assemblies, outside corners, and inside corners shall be solid wood or solid bamboo and a finish to match the chair rail.

B. Fasteners: All mounting systems accessories appropriate for substrates indicated on the drawings shall be provided.

2.05 FINISHES

A. Wood/Bamboo Stain: Color of the chair rail to be selected, by the architect, from the IPC stain selection. Bamboo color shall be natural or carbonized.

B. Wood/Bamboo Finish: Chair rail shall be finished with a water-based clear coat finish. Finish shall be a low luster satin finish.

PART 3 EXECUTION

3.01 INSTALLERS

A. Installer should be familiar with the installation of fine finished wood products.

3.02 EXAMINATION

A. Examine areas and conditions in which chair rail will be installed.

1. Complete all finishing operations, including painting, before beginning installation of chair rail materials.

2. Wall surface shall be dry and free from dirt, grease and loose paint.

3.03 PREPARATION

A. General: Before installation, clean substrate to remove dust, debris and loose particles.

3.04 INSTALLATION

A. General: Locate the chair rail as indicated on the approved detail drawing for the appropriate substrate and in compliance with the IPC installation instructions. Install chair rail level and plumb at the height

indicated on the drawings.

B. Installation of the pre-assembled CR1 Chair Rail.

1. Pre-assembled chair rails are shipped in pre-cut lengths with reverse miter cut end caps. Inside and outside corners are miter cut.

2. Layout and identify the components needed for each section to be installed. Drill ¹/₈" (3mm) holes in the chair rail 4" (102mm) from each end, in a zigzag pattern, and spaced evenly over the length of the rail. Use six fasteners per 12' (3.66m) length.

3. Transfer the mounting holes to the wall, drill ¹/₄" (6.5mm) holes in the wall and mount the chair rail to the wall with ALLIGATOR anchors and fasteners. Fill the screw holes with wood putty from the touch up kit.

4. Glue and pin nail inside and outside corner conditions. Clean up any wood glue with a damp cloth. Fill the nail holes with wood putty from the touch up kit.

C. Installation of stock length CR1 Chair Rails

1. Chair rails are shipped in 8' - 16' (2.44m - 4.88m) lengths. Factory made end caps must be field cut. Inside corners and outside corners must be miter cut, glued and pin nailed.

2. Cut the chair rail to the required length. Drill ¹/₈" (3mm) holes in the chair rail 4" (102mm) from each end, in a zig-zag pattern, and spaced evenly over the length of the rail. Use six fasteners per 12' (3.66m) length.

3. Transfer the mounting holes to the wall, drill ¹/₄" (6.5mm) holes in the wall and mount the chair rail to the wall with ALLIGATOR anchors and fasteners. Fill screw holes and nail holes with wood putty from the touch up kit.

3.05 CLEANING

A. At completion of the installation, clean surfaces in accordance with the IPC clean up and maintenance instructions.

