

- Slim base(s) with access door, 6 leveling glides each
- Flared base(s) with access door, 6 leveling glides each
- Drum base with access door, 6 leveling glides each
- Support: two beams or four beams with clamps
- Four beam end caps
- Tech corridor doors
- Tech door clips
- Cable clips for power/data cables
- Power infeed
- Tops: round, rectangular, soft radius, racetrack, boat and trapezoid

- TAP door assembly
- TAP tray assembly
- Storage tray assembly

Optional accessories:

- Corridor shelf
- Floor kit: Connectrak™
- Six outlet plug
- Outlet Receptacle Kit

VECTA

A Steelcase Company

table assembly instructions

Host™

Design: f/p design &
Vecta Design Team

TWO BEAMS, TWO BASES, ONE PIECE TOP TABLE

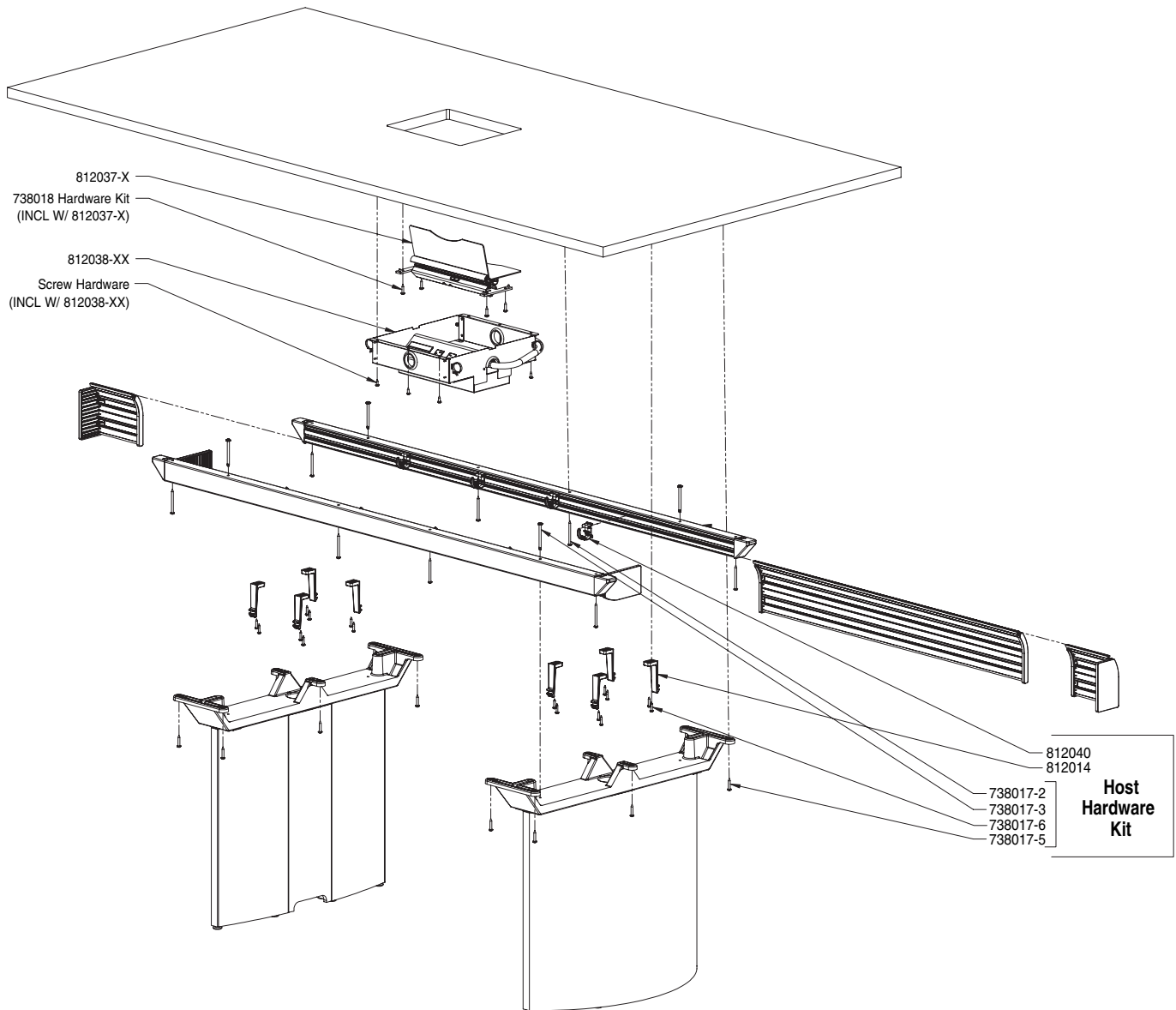

BASE LOCATIONS:

Remove base assembly from packaging by unscrewing the base glides. Remove pad and reattach glides to the base.

Place bases in their approximate final locations. End bases will be centered 24" from the end of the top. See Fig. 1.

Tip: In most cases, base access doors should face inward.

Tip: Bases can be the same style or a combination of slim and flared. Bases are located in the same position for any given table top, regardless of table shape.

Base Access Doors

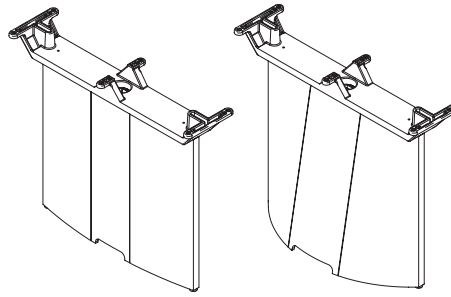

Slim Base

Flared Base

Base Footprints

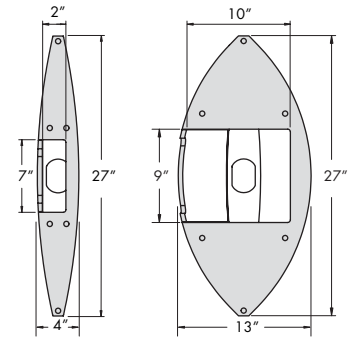

Slim Base

Flared Base

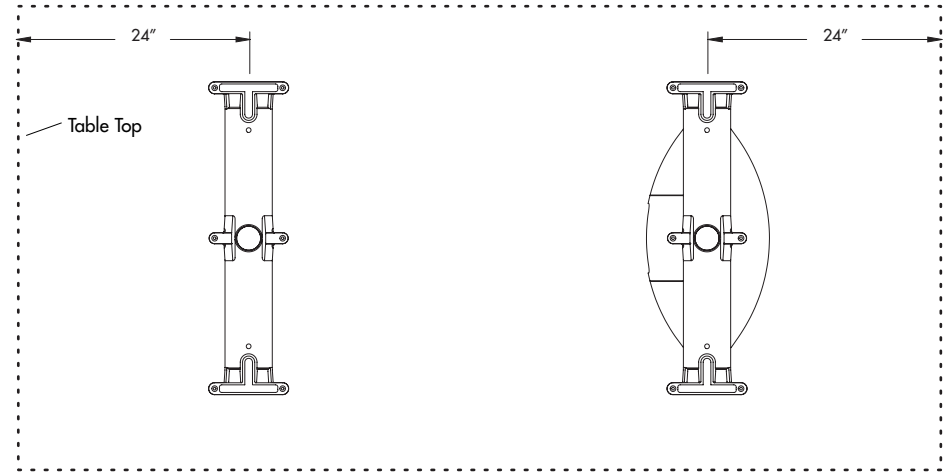

Fig. 1

TECH CORRIDOR ASSEMBLY:

Place beams, tech doors, and end caps on the floor as shown. See Fig. 2.

Remove beam end caps.

Slide long tech doors on to hinge of each beam. See Fig. 3.

Slide short tech doors on to each end in the same hinge. See Fig. 3.

Fig. 2

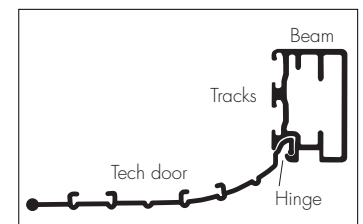
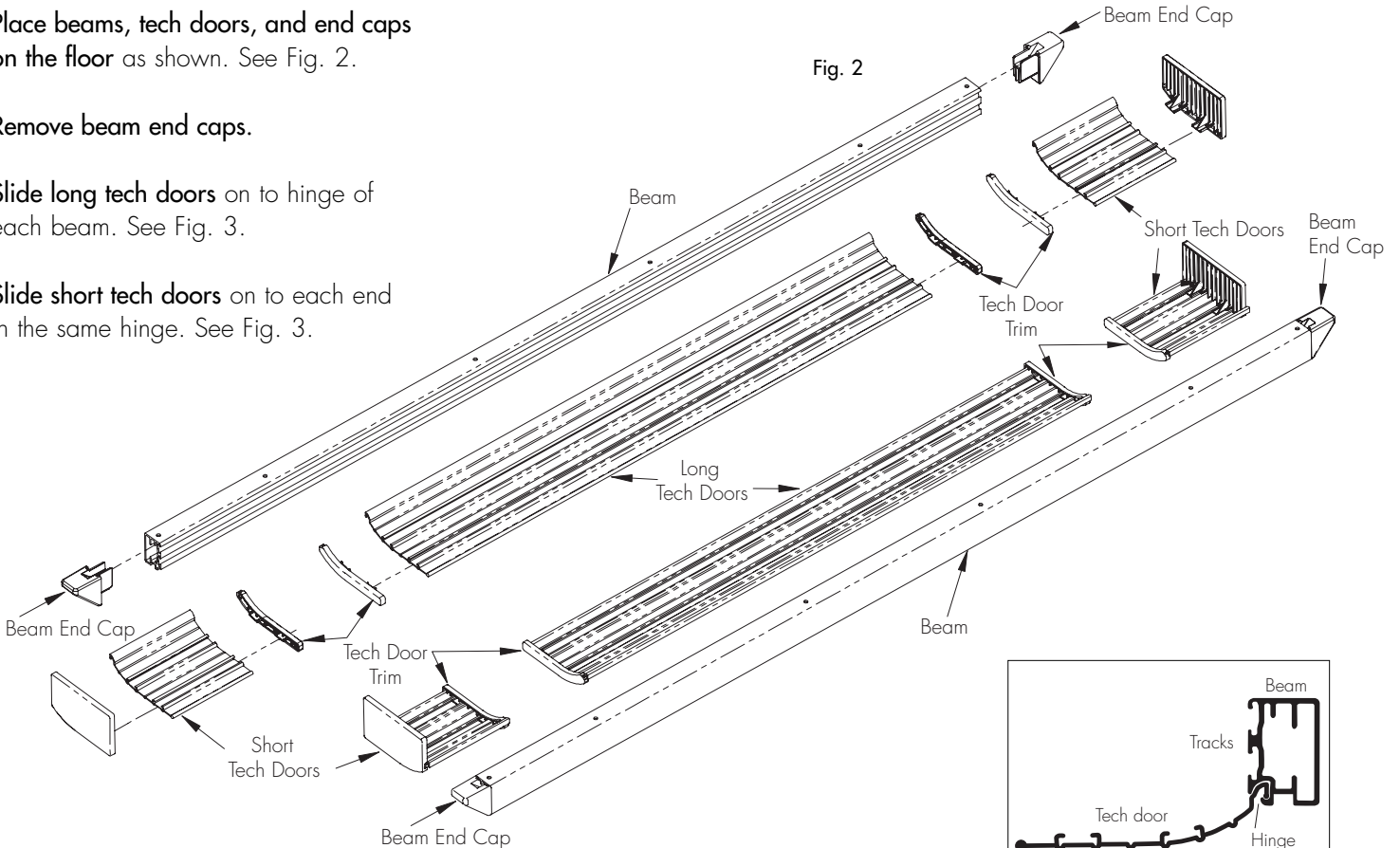

Fig. 3

TWO BEAM TABLES: 96"L, 10'L, 12'L

Place beam/tech doors assemblies facing each other on to the bases with the long doors between the bases and the short doors outside the bases. See Fig. 4.

Push beam end caps in to the ends of the beams.

Tip: Do not screw the end caps to the beams yet.

Tip: 10'L and 12'L tables have two long middle tech doors on each beam.

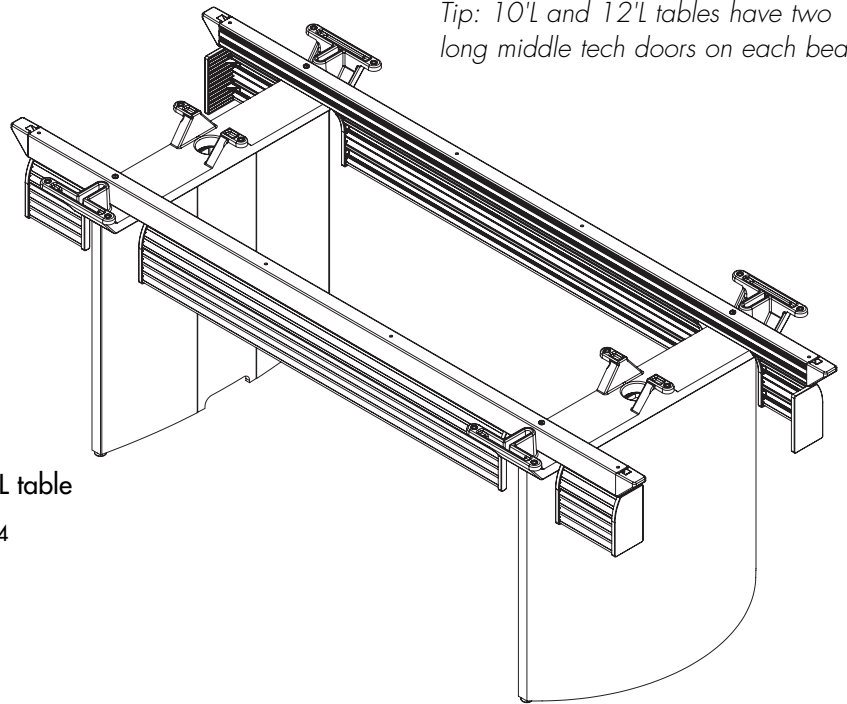

96"L table

Fig. 4

Align the second predrilled hole from each end of the two beams with the holes in the bracket castings. See Fig. 5.

Start the (C) Pan Head screws in to each bracket casting. DO NOT Tighten.

Tip: (C) Pan Head screws remain above beam to aid in table top alignment. See Fig. 6.

C

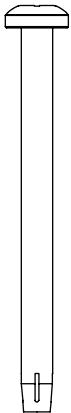

SCREW 1/4-20 X 3.00
PHILLIPS PAN HEAD
TYPE-F CLEAR ZINC

Fig. 5

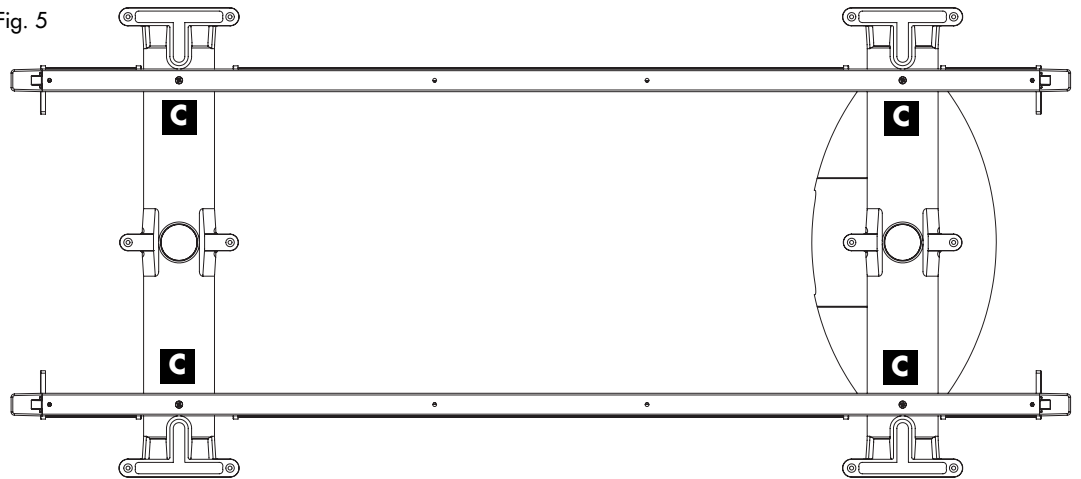
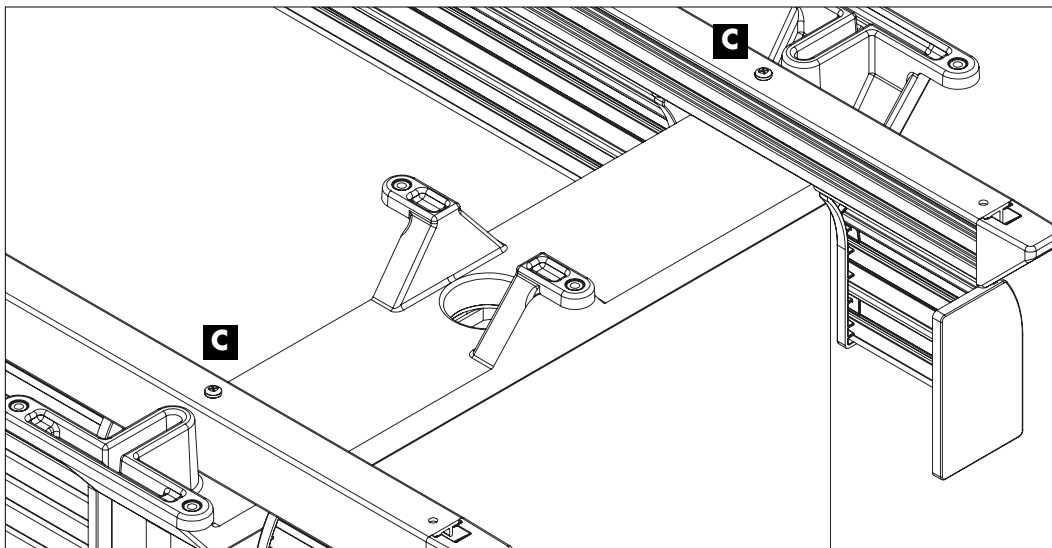

Fig. 6



Level the bases.

Check the square alignment of the beams. See Fig. 5.

Tighten screws.

FOUR BEAM TABLES: 14'L, 16'L, 18'L, 20'L

Place and center the three bases where they should be in the room and assemble the tech corridor, see page 2.

Tip: End bases are centered 24" from the end of the top. See Fig. 1. Middle base is positioned in the center of the table. See Fig. 7.

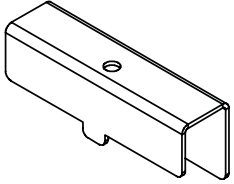

Rail Clamp splices the two beams together at the center base.

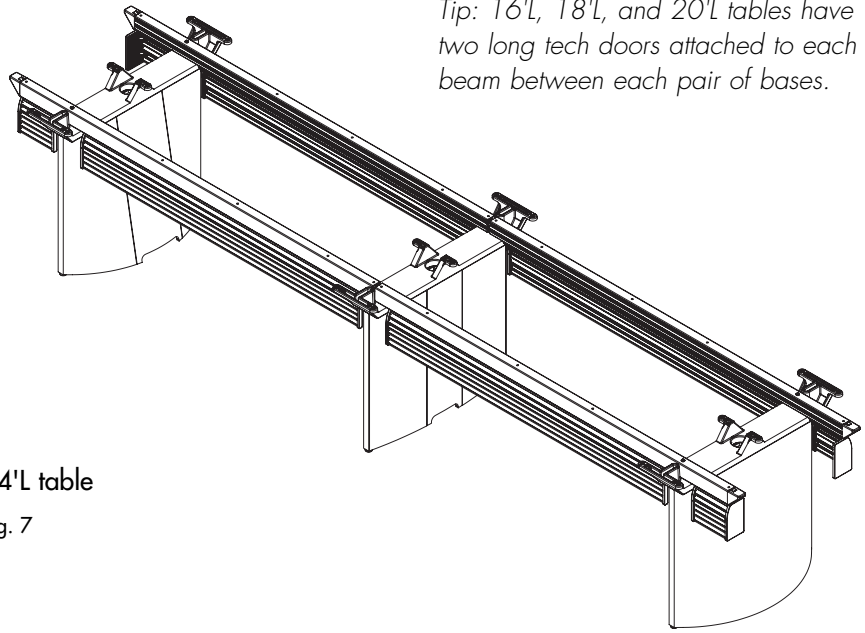

14'L table

Fig. 7

Tip: 16'L, 18'L, and 20'L tables have two long tech doors attached to each beam between each pair of bases.

Align black rail clamps with predrilled holes in center base bracket casting. Position each clamp with the tab pointing downward, and the short side of the clamp facing inward. See Fig. 8.

Secure with (B) black self-tapping screws finger tight.

Place beam/tech doors assemblies facing each on to the bases with the long doors between the bases and the short doors outside the end bases. See Fig. 7.

Slide a pair of beams on to each rail clamp. Push both beams against the tab at the bottom of the clamp, forming a 1/2" gap between the beams. See Fig. 9.

Tighten each black screw on each clamp to ensure the gap remains unchanged.

Check the square alignment of the beams. The clamped beams can pivot as needed to square the frame.

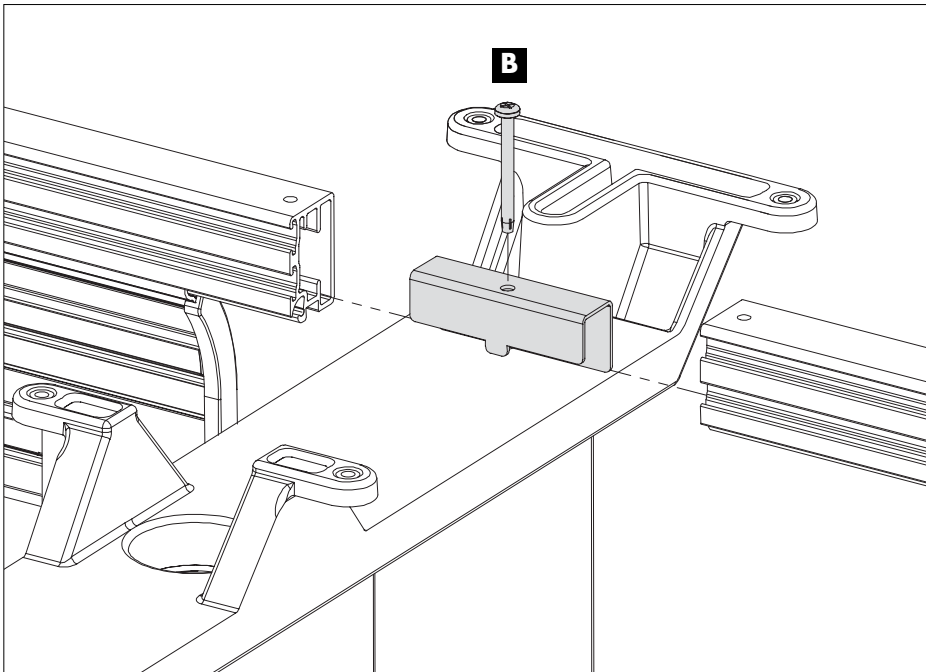

Fig. 8

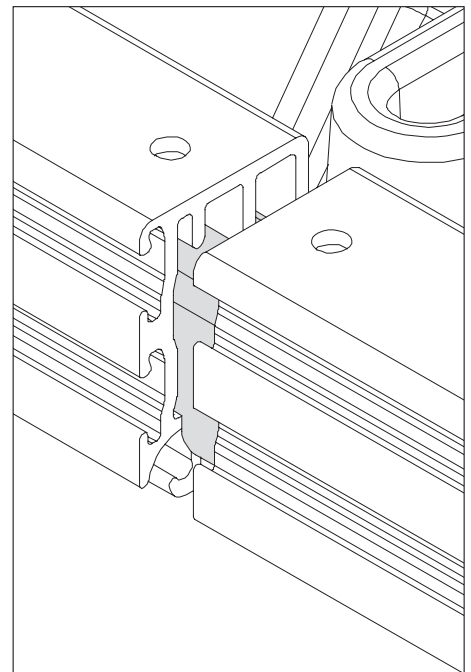
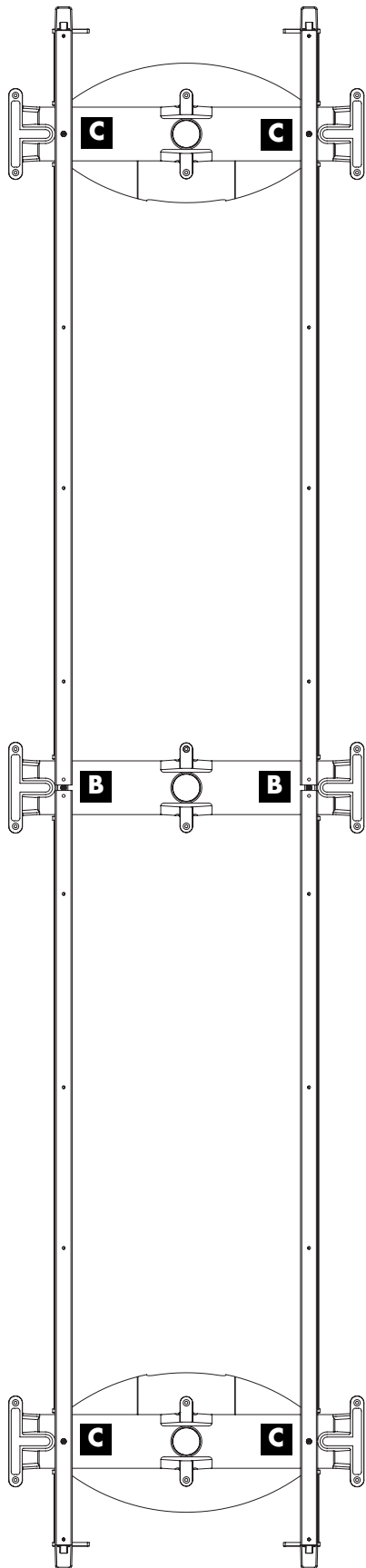

Fig. 9

Fig. 10



Clamp to base

Beam to base

B

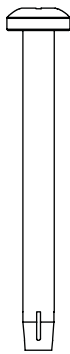

C



SCREW 1/4-20 X 2.50
PHILLIPS PAN HEAD
TYPE-F BLACK ZINC

SCREW 1/4-20 X 3.00
PHILLIPS PAN HEAD
TYPE-F CLEAR ZINC

Align the second predrilled hole from the end of the each beam with the holes in the end base bracket castings. See Fig. 10.

Start the (C) Pan Head screws in to the bracket casting.

Tip: Pan Head screws remain above beam to aid in table top alignment. See Fig. 11.

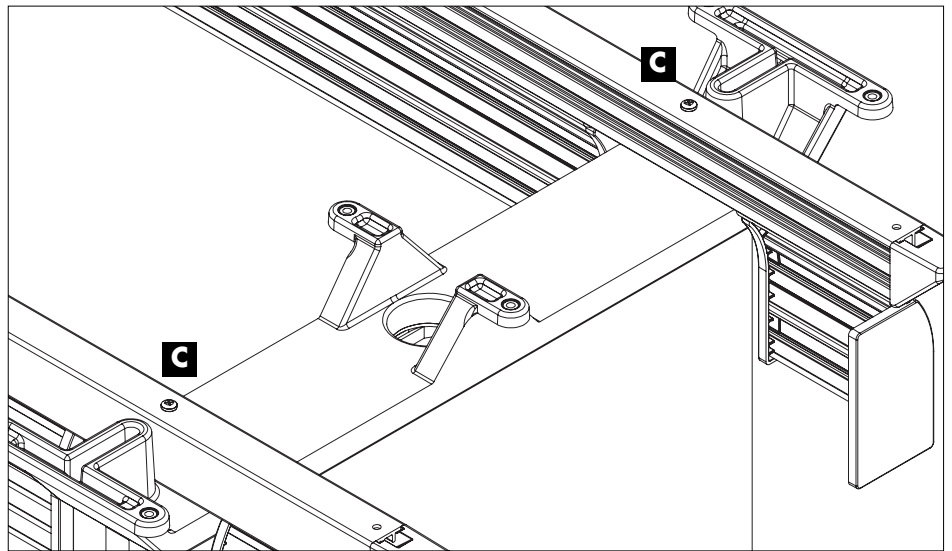

Fig. 11

Level the bases.

Check the square alignment of the beams. See Fig. 10.

Tighten all screws.

OPTIONAL MODULAR INSTALLATION

Fig. 12

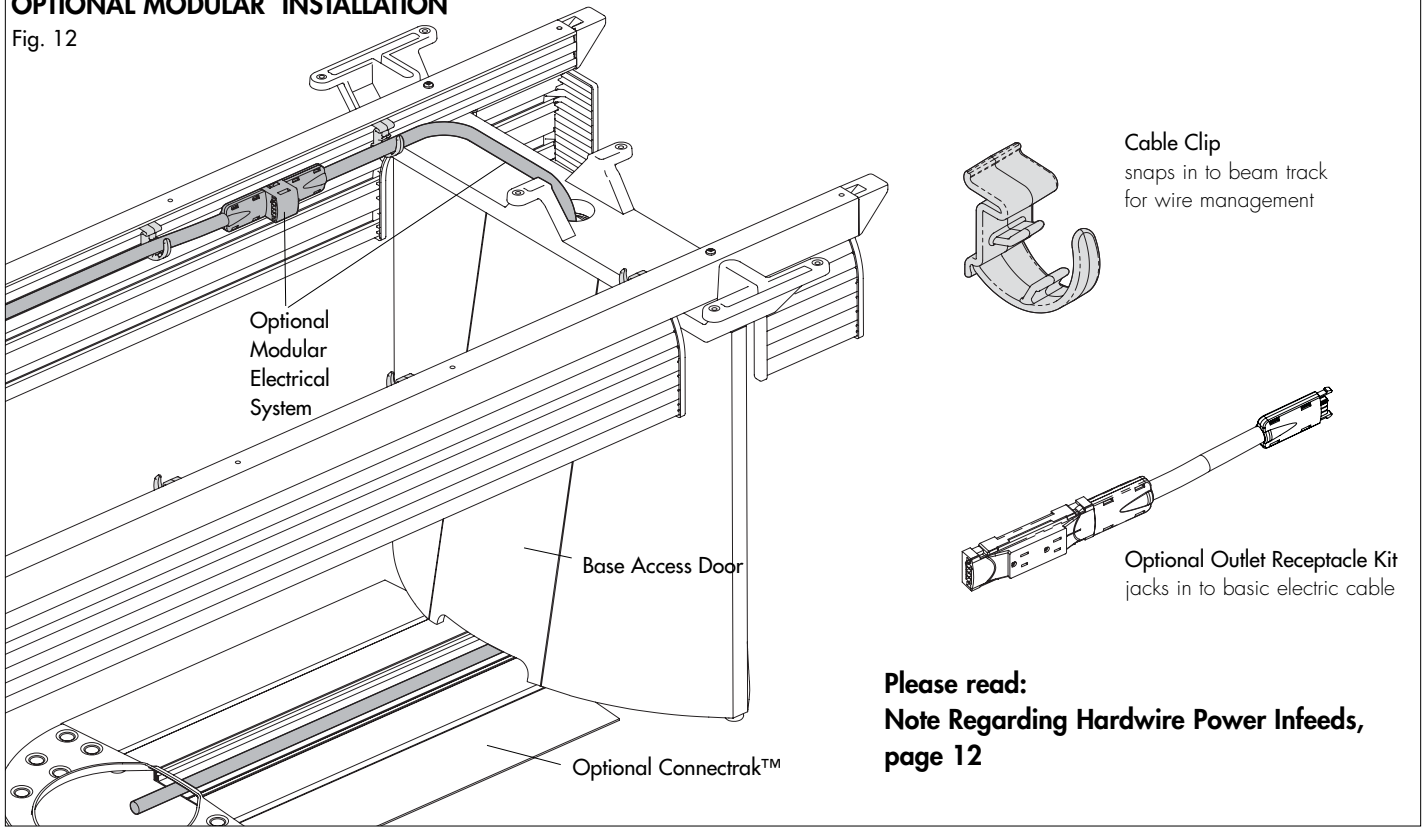

If optional modular electrical system is specified, bring wiring up through base from floor monument or base access door into Tech Corridor. See Fig. 12.

Connect electrical cables and secure with cable clips as required.

Run data wires along opposite beam and secure with cable clips as required.

ONE PIECE TOP PILOT HOLES (Also see SECTIONED TOPS for more locations, page 11.)

- C Alignment index holes
- D Beam mounting holes

- E Base bracket mounting holes
- F Tech door clip mounting holes

- G TAP door index pin/mounting holes
- H TAP tray mounting holes

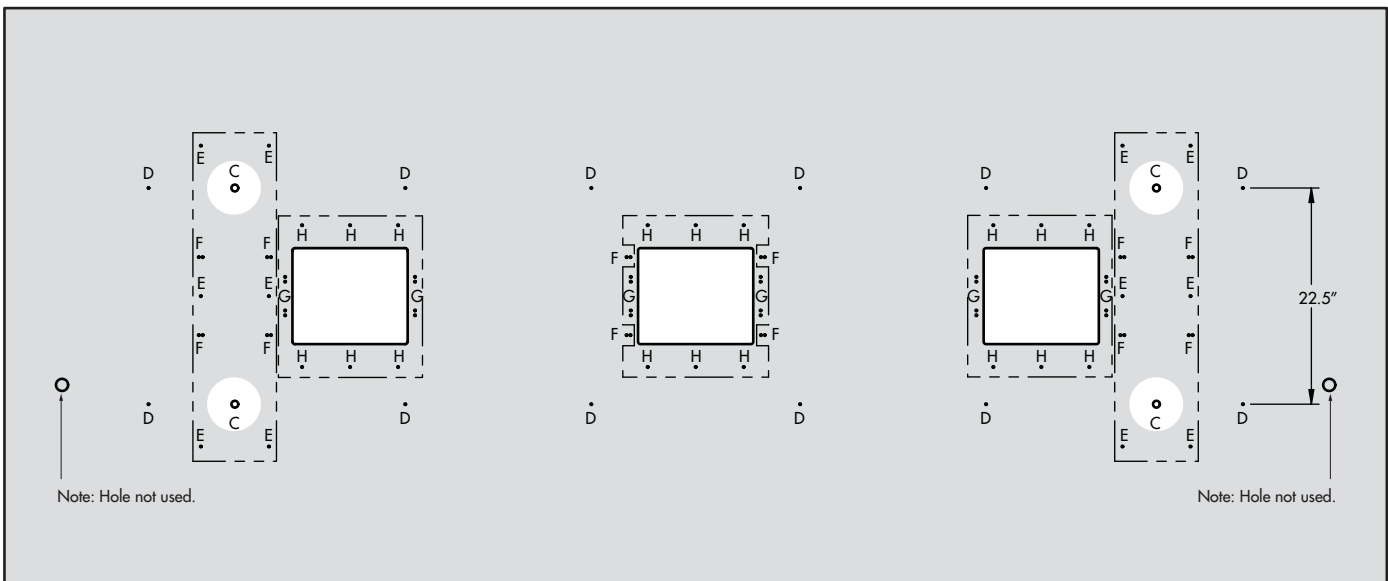

Fig. 13

Place table top on to assembled base/Tech Corridor.

Align the counter bored holes (C) underneath the top on to the

Pan Head screws (C) used to secure the beams to the bracket castings.

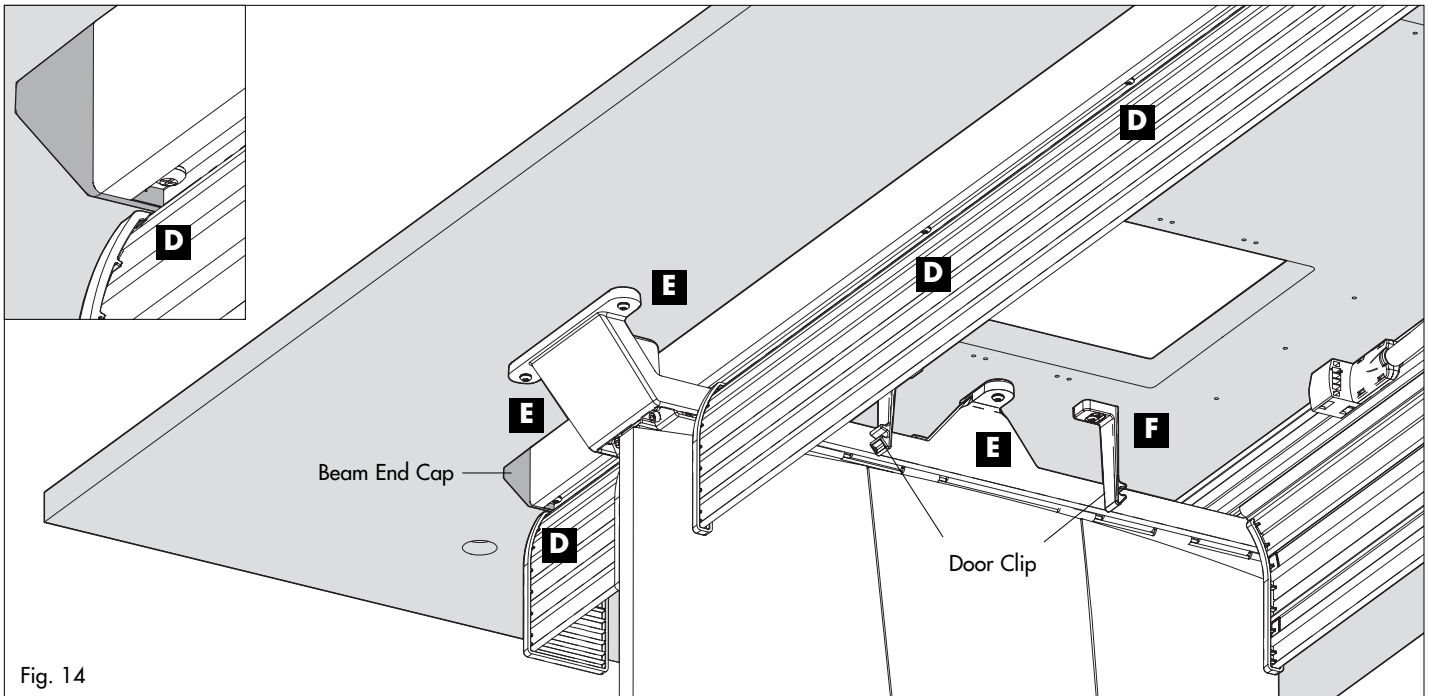

Fig. 14

TOP INSTALLATION

Tip: Check to make sure all beam end caps have been inserted into all beam ends before securing top to beams.

Tip: Check to ensure that the bases and beams are squared and leveled before the top is attached.

Check top alignment. Counter bored holes on underside of top fit on to the Pan Head screws on each end base. See pages 3 and 5

Start screws (D) through beam end caps and beams in to pilot holes in the table top. After all beam screws are started, finish tightening all beams screws from the center to the ends. See Fig. 14.

Install screws (E) through bracket casting holes into pilot holes in the table top. (6 screws/bracket) See Fig. 14.

DOOR CLIP INSTALLATION

Install each door clip with screws (F) into pilot holes in the table top. (2 screws/clip) See Fig. 14.

Tip: One clip/short tech door. Four clips/long tech door.

Beams to table

D



SCREW 12 X 2.75
PHILLIPS PAN HEAD
TYPE-A CLEAR ZINC

Base to table

E



SCREW 12 X 1.25
PHILLIPS PAN HEAD
TYPE-A CLEAR ZINC

Door clip to table

F



SCREW 10 X 1.00
PHILLIPS PAN HEAD
TYPE-A BLACK ZINC

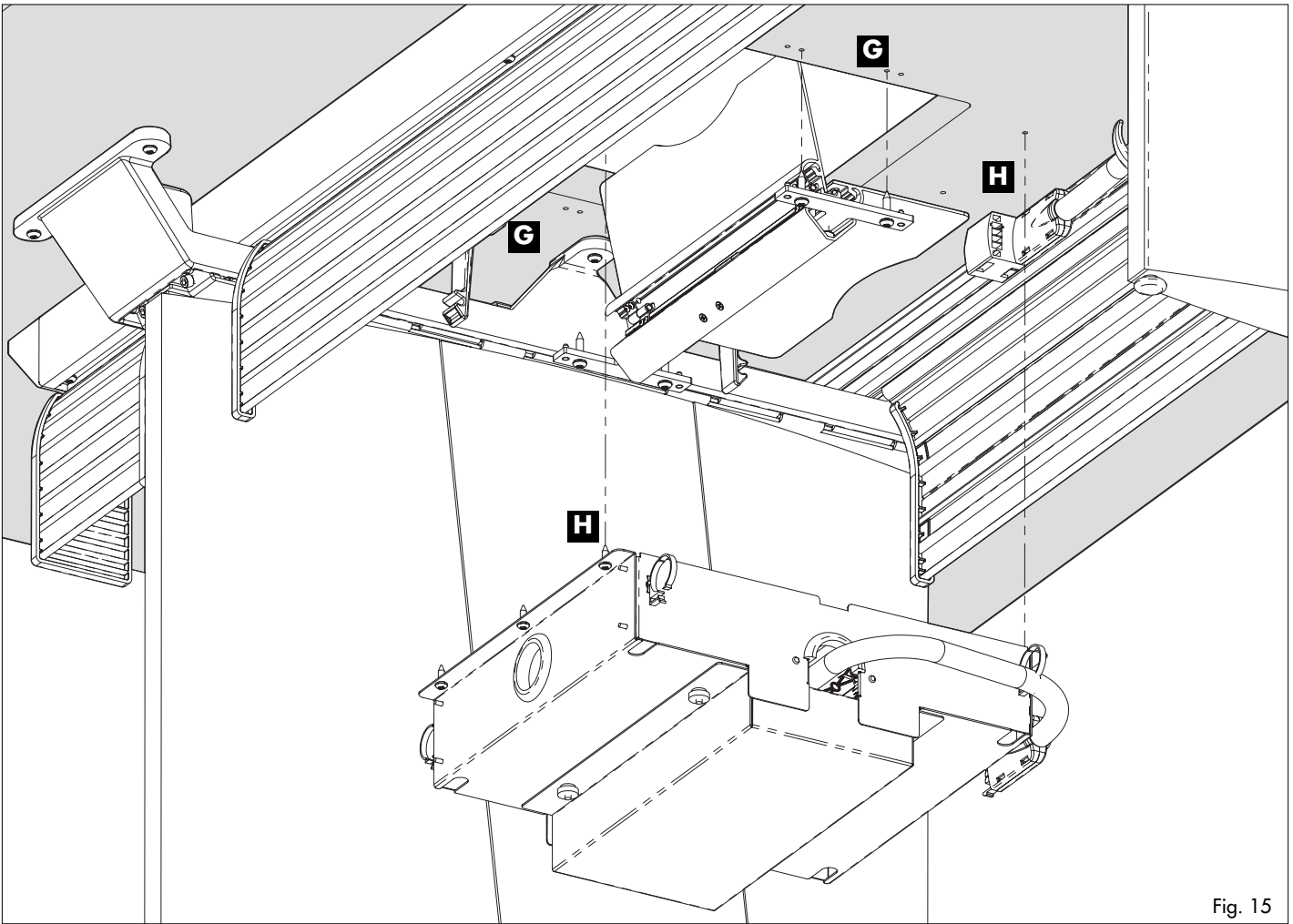

Fig. 15

TAP DOOR INSTALLATION

Install TAP doors by locating the four alignment pins into pilot holes and securing with four screws included with the TAP assembly into location (G). See Fig. 15 and 16.

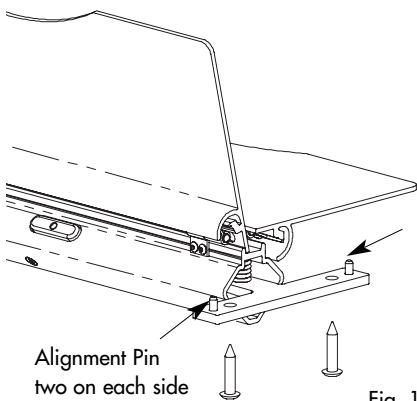

Fig. 16

TAP TRAY INSTALLATION

Install TAP tray by locating into place and securing with six screws included with TAP tray assembly into location (H). See Fig. 15.

Tip: Tray can be prewired before installation.

Tip: To access tray wiring from under the table, remove thumbnuts from cover. See Fig. 17.

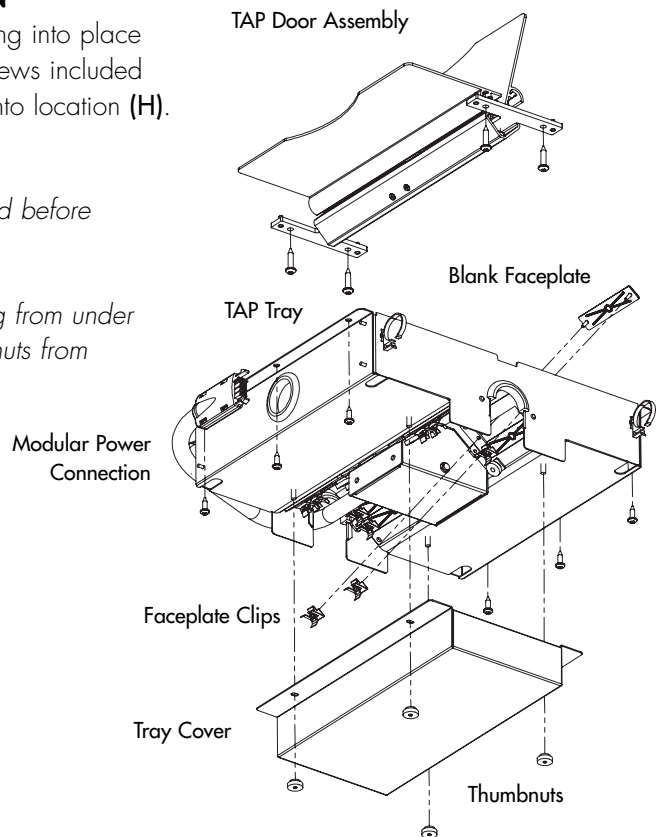
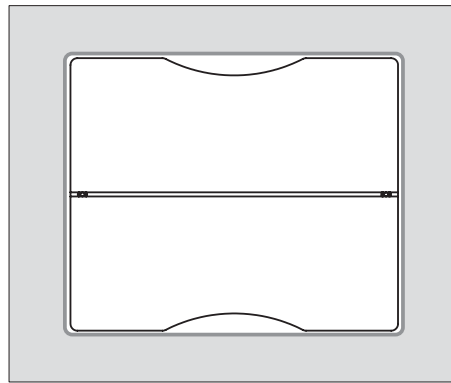

Fig. 17

TAP DOOR ADJUSTMENTS

CAUTION: TAP DOORS AND STORAGE TRAY DOORS CAN BE EASILY SCRATCHED WITH HEX KEYS. MAKE SURE BOTH DOORS ARE FULLY OPEN BEFORE MAKING ADJUSTMENTS.



STORAGE TRAY ADJUSTMENTS

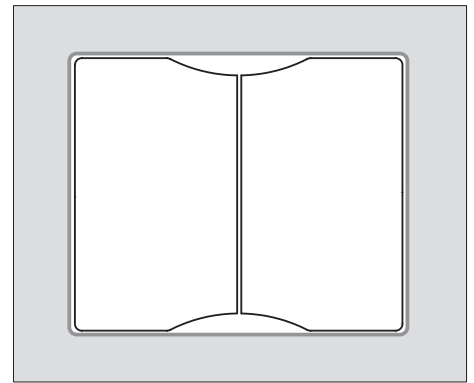

Adjust the pitch first, then adjust the height.

Adjust the pitch of each door to be level with the table surface by adjusting the Allen screw found under each door.

Adjust the height of the left and right sides of the TAP door assembly to be flush with the table surface by adjusting the Allen screws on top between the doors. There is an adjustment screw at each end of the TAP assembly. Doors must be fully open to adjust screws.

Access to height adjustment screws

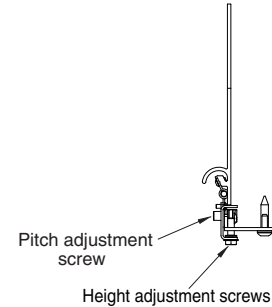
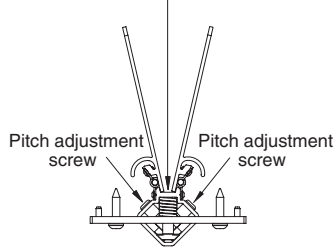

STORAGE TRAY

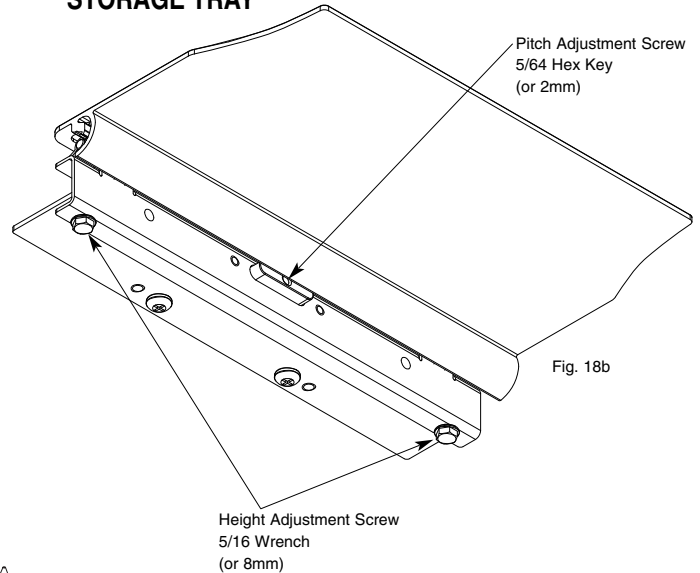

Fig. 18b

TAP DOOR

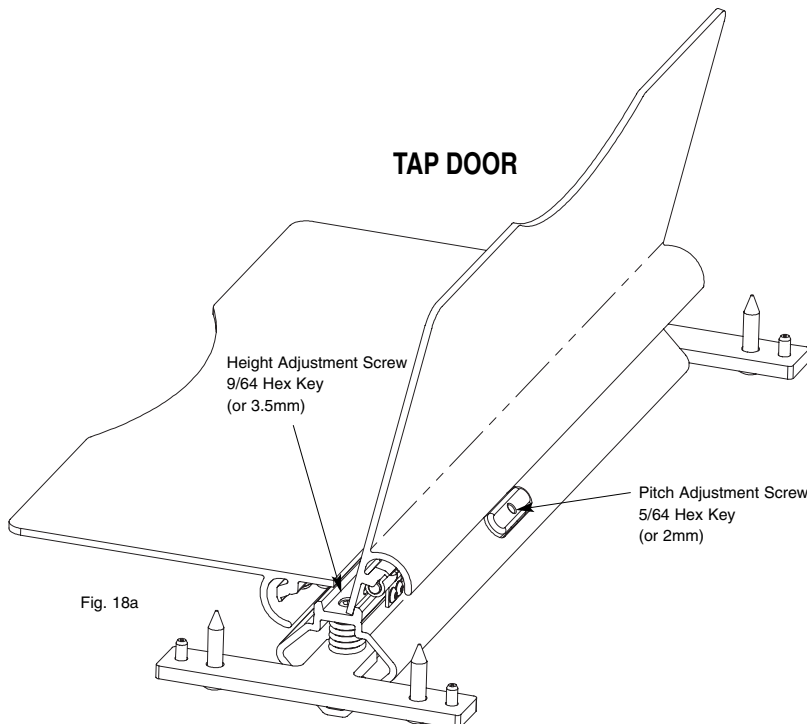

Fig. 18a

Adjust the height of the left and right sides of the storage tray assemblies to be flush with the table surface by adjusting the Allen screw inside each door. There is an adjustment screw at the end of each of the storage tray assemblies. Door must be fully open to adjust screw.

MODULAR SYSTEM TAP TRAYS
 CONNECTION EXAMPLE WITH ACCESSORIES

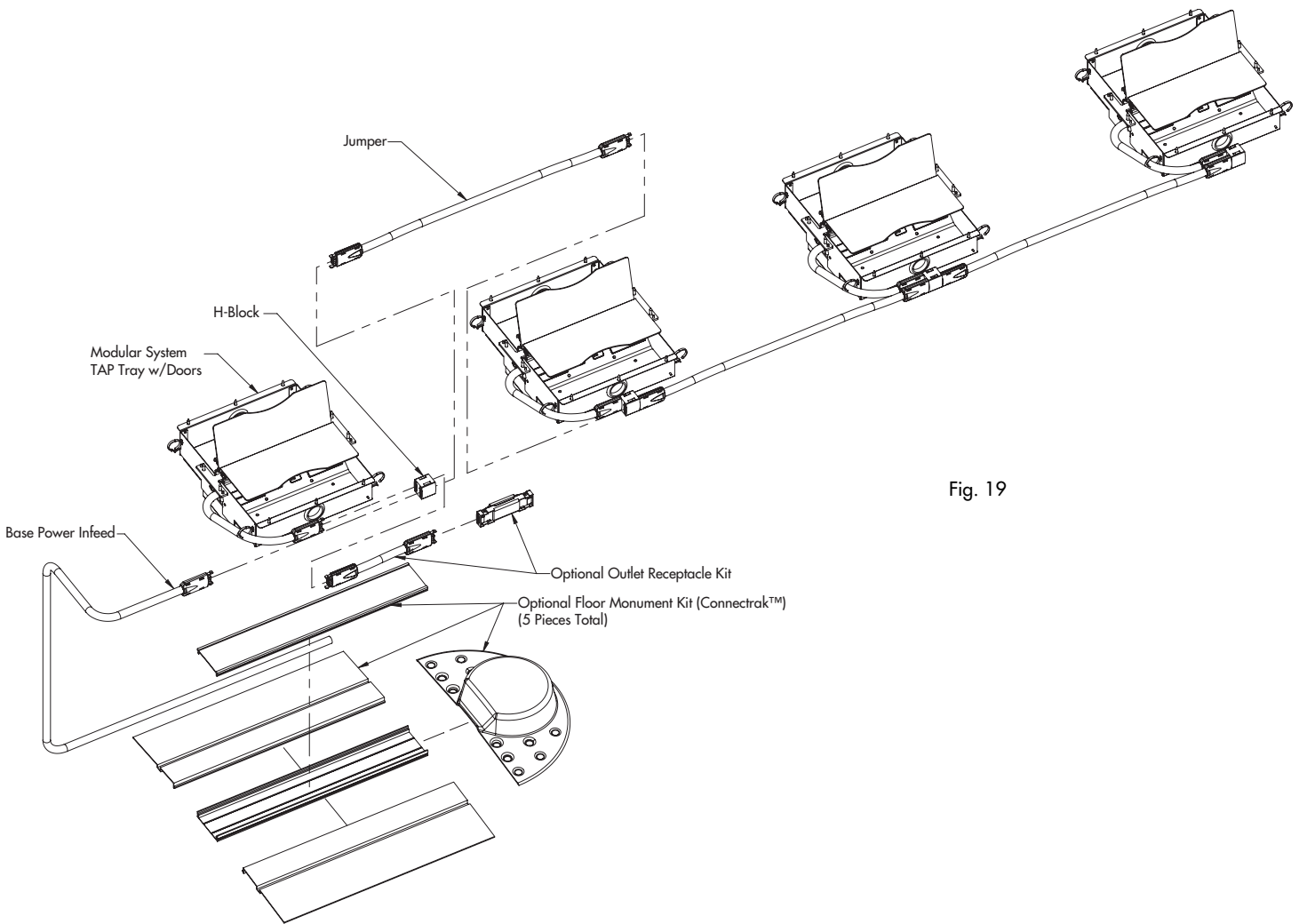

Fig. 19

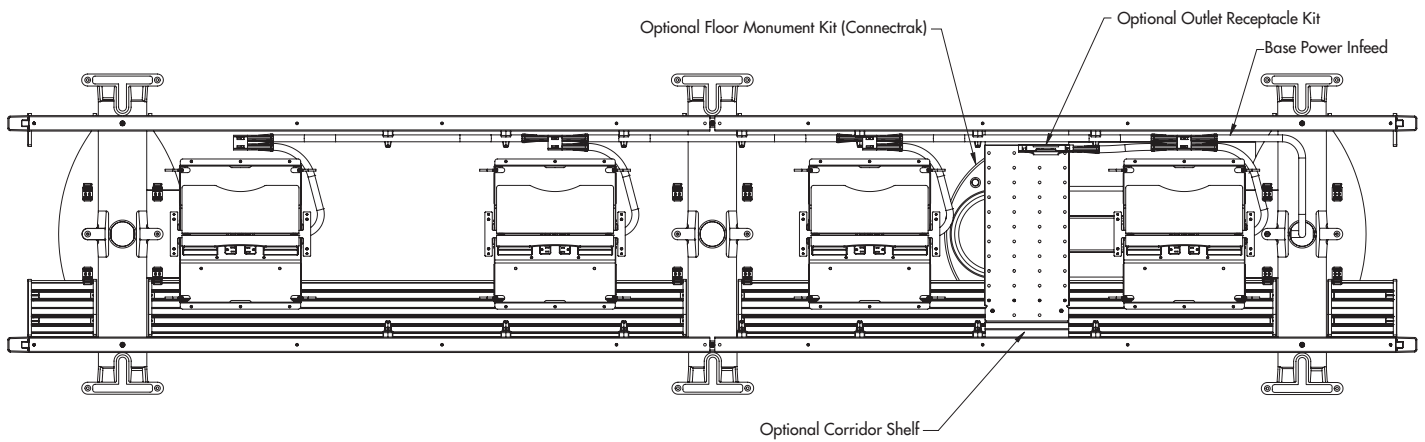
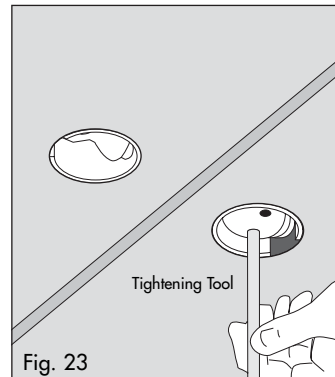
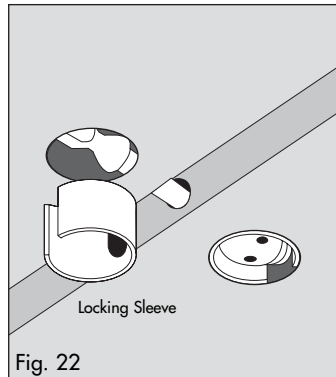
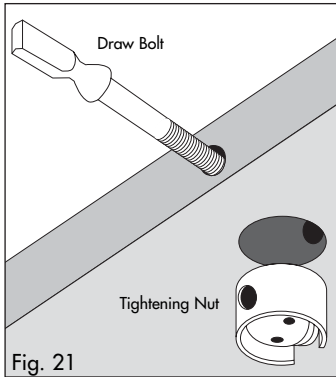

Fig. 20
 14'L table with four TAPs

**Please read:
 Note Regarding Hardwire Power Infeeds,
 page 12**

JOINING SECTIONED TOPS



Insert **Tightening Nuts** in to alternating holes in table top sections with threaded ends towards the joint. Fig. 21

Insert the **Draw Bolts** and thread each into the nut leaving 1 1/8" of bolt to fit into joining section. Fig. 21

Insert **Locking Sleeves** into remaining holes to engage the head of the draw bolt. Fig. 22

Tighten nut with tightening tool thus drawing joints together. Fig. 23

Tip: For grain matching, top sections are in numbered sequence on the underside.

Align end top section with Pan Head screws on end base.

Insert Tite-Joint Fasteners.

Locate alignment bullets to aid in joining sectioned tops.

Alternate tightening tite-joint fasteners to join one section with another section. Begin with the center fastener and alternating left and right toward the outside of the top. As top sections come together, adjust tite-joints for a leveled, even seam between sections.

Level the bases.

Check alignment of the joined top on the bases.

Attach beams and bases to top.

Attach TAP doors and trays, if any, to top.

SECTIONED TOPS PILOT HOLES

- C Alignment index holes
- D Beam mounting holes

- E Base bracket mounting holes
- F Tech door clip mounting holes

- G TAP door index pin/mounting holes
- H TAP tray mounting holes

Fig. 24 Two Piece Top Mid Base Location

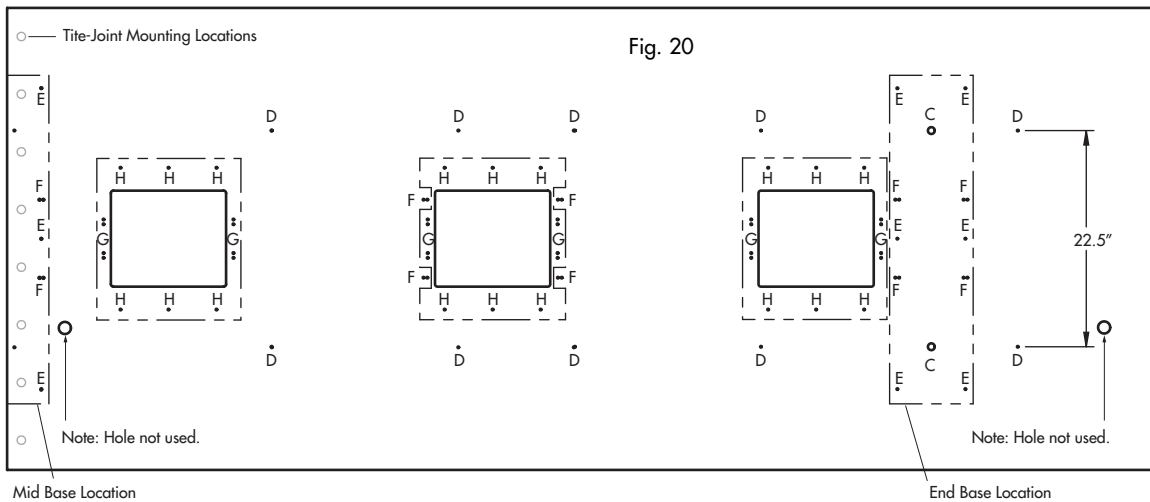
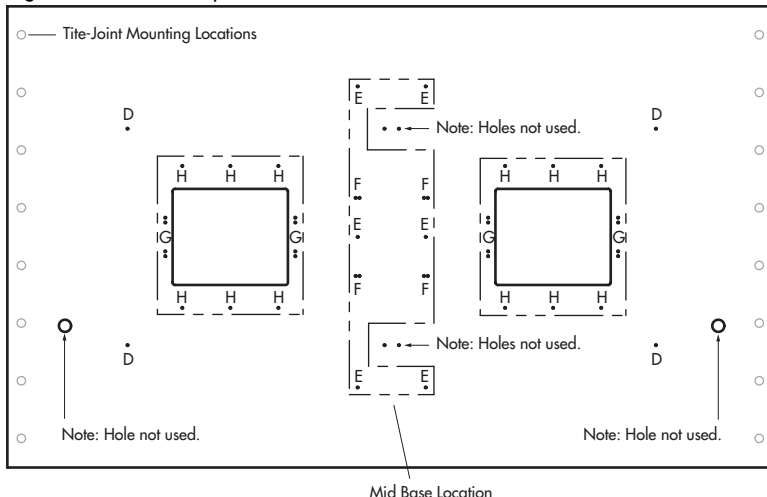
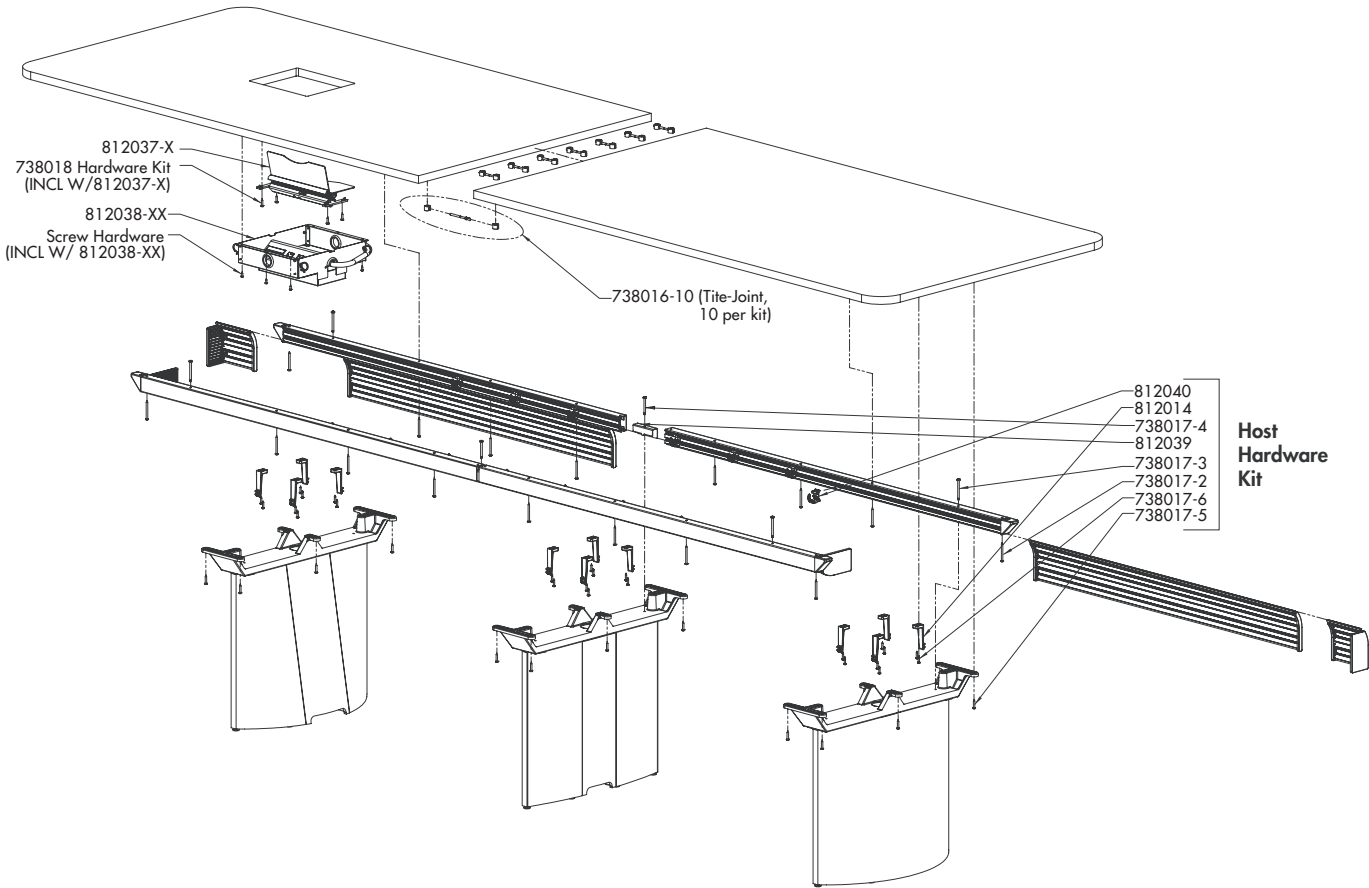

Fig. 25 Three Piece Top Mid Base Location



Bases are located in the same position for any given table top, regardless of table shape. Bases can be the same style or a combination of slim and flared.

FOUR BEAMS, THREE BASES, SECTIONED TOP TABLE



DRUM BASE TABLE

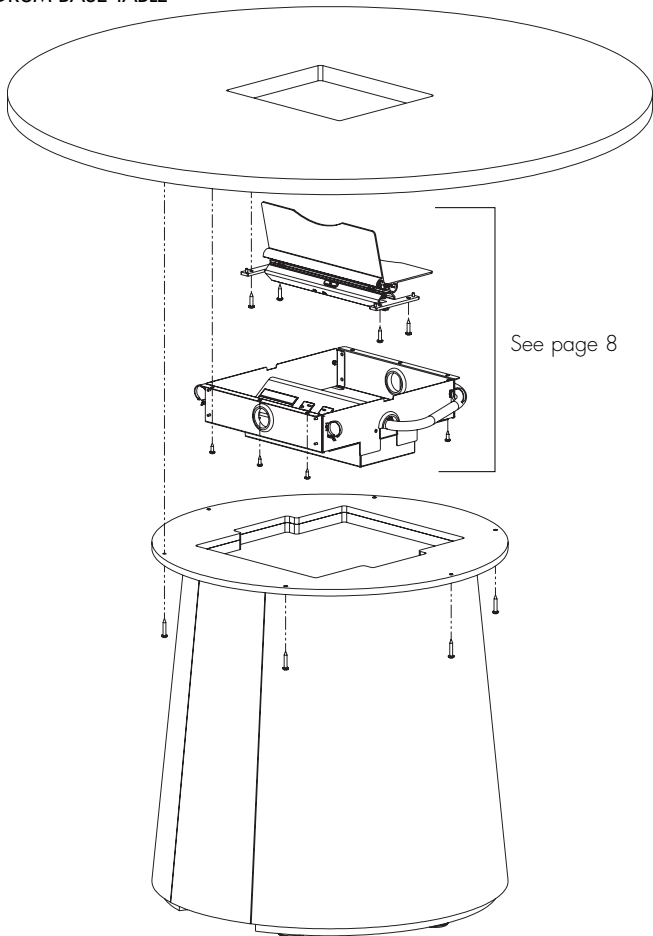

Note Regarding Hardwire Power Infeeds

A licensed electrician must connect the power infeed(s) to the building power source in accordance with all national and local electrical codes. These electrical assemblies are intended for installation in accessible, dry locations in accordance with Article 604 of the National Electric Code NFPA70. If you have any concerns about a specific application, please consult the local authority having jurisdiction. This system is rated for a maximum of 20 amps, 125/250 V, 1-Phase, 60Hz or 120/208 V, 3-Phase, 60Hz.

WARNING: "RISK OF FIRE OR ELECTRICAL SHOCK. DO NOT ELECTRICALLY CONNECT TO MORE THAN ONE SOURCE OF SUPPLY. ALWAYS DETERMINE THAT THE WIRING ASSEMBLY IS ELECTRICALLY CONNECTED TO ONE and ONLY ONE SOURCE OF SUPPLY."