

Turnstone Furniture Specification Guide

What's New?

Spec News is available on in2.steelcase.com. Go to *Specification Guides-AdStock*, under *Sales Resources/Sales Marketing Materials*, and download the current release's Spec News.

Availability

Electronic price list updated with release 174.E (U.S.) and 143.E (Canada), dated February 20, 2012.

Transitional products in this specification guide are **maintained for existing customers only** and are likely to be phased out over time. These products are indicated with a . Products that are scheduled to be culled are indicated with an , followed by the last order entry date.

► For a list of all trademarks, refer to the last page of this specification guide.

This specification guide contains multiple Steelcase and Turnstone product lines which are designed into one specification guide for your convenience. Note that each product may be subject to different pricing terms and conditions.



For Canadian Pricing

Calculate in the following order to avoid rounding errors:

- Multiply the base price and each option by 1.03.
- Round each to the nearest dollar.
- Add base and options for total list price.

Terms and Conditions	2
Additional Resources	3
<hr/>	
Bivi	5
Tour Workspace	41
Campfire	107
Seating	135
Tables	199
Details Ergonomic Worktools	209
<hr/>	
Surface Materials	241
Resources	263

Terms and Conditions

Terms

Payment terms for Turnstone are the same as current Steelcase terms, providing you the opportunity for additional cash discounts for prompt payments.

Payment for Turnstone brand products can be remitted with payments for Steelcase brand products. You can even use the same check!

Past due amounts are subject to 1.5% service charge per month on the unpaid balance.

Returns

If product you have received must be returned because of Turnstone error or quality issues, your SFT representative can help. All returns must be authorized; products that are not authorized for return will not be accepted.

Claims

For freight claim information, go to www.in2.steelcase.com, then Order Management, then Service and Warranty, then Freight Claims.

Order Changes

All orders delivered within standard lead times are considered final and cannot be changed.

Any charges for changes or cancellations are the responsibility of the dealer.

Special order products cannot be changed or canceled.

Freight Costs

All shipments to points in the 48 contiguous states will be shipped factory freight prepaid (FOB).

All shipments outside the 48 contiguous states will be shipped FOB and allowed to point of embarkation. All charges beyond the point of embarkation are collect.

Call 1.800.TURNSTONE, option #2 for quotes on Expedited shipments, UPS delivery, or deliveries outside the continental U.S.

Turnstone reserves the right to select the most appropriate mode of shipment from the manufacturing point and point of embarkation.

Special shipping methods, handling, or setup will be subject to an additional charge.

Delivery/Lead Times

Most products will be shipped in 5-7 business days after receipt of a clean order. Products are typically delivered 10-12 business days. Exceptions are Payback products which will typically deliver within 15 business days.

Leadtimes are subject to available capacity.

Please call 1.800.TURNSTONE and ask for your Solutions Fulfillment Team Representative for orders in excess of 50 units.

For up-to-date lead times, consult the scheduling/delivery schedules bulletin board on www.in2.steelcase.com, then Order Management.

Surface Materials

Only fabric price groups 1-3 will ship in 5-7 business days. Standard Turnstone laminates and paints will ship in 5-7 business days. Established and transitional finishes and fabric price groups 4 and higher will deliver in 15 business days or more. COM, PerfectMatch, Open Line laminate and Specials orders are scheduled based on material availability. Please see the Surface Materials chapter for exceptions and additional details.

Assembly

Due to construction, design of the product, or delivery conditions, it is necessary to ship most Turnstone products cartoned. Turnstone products that are shipped unassembled are shipped RTA (ready to assemble) and are easy to assemble.

Turnstone products are supported with an array of informational materials, tools, and software to help you plan and install efficiently.

Product brochures and planning tools can be ordered through your Steelcase area office, by calling 1.800.784.0358, or through the Steelcase Marketing Communications Web site at www.in2.steelcase.com.

Product Brochures

Seating Product Overview Sheets

Crushed Can
Form Number 03-0000868

Jenny
Form Number 09-0000373

Lincoln
Form Number 08-0000220

alight
Form Number 08-0000216

Scoop
Form Number 08-0000241

Desking Product Overview Sheets

Tour
Form Number 09-0000862

Campfire
Form Number 10-0002592

Surface Materials

Turnstone Surface Materials Swatches

Individual swatches, larger memo samples, and family group swatch cards are available by contacting Ad Stock at 1.800.784.0358 or by ordering electronically at www.in2steelcase.com.

Printed Materials

Surface Materials Reference Manual

This publication provides:

- An explanation of the surface materials program
- "Available on" matrices
- Vertical surface fabric and seating upholstery selection listing
- Technical data for surface materials
- Surface material care and cleaning instructions

Computer Tools

On the Web www.turnstonefurniture.com

Visit Turnstone's Web site for a complete product listing, photos, case studies, where to find a Turnstone dealer, and much more.

Bird's Nest

Turnstone's dealer Web site includes pricing and terms, user guides, case studies, spec guides, lead times, printable brochures, photos, and more. Dealers access Bird's Nest through www.turnstonefurniture.com, using their in2.steelcase.com password.

Furniture symbol graphic data are available for download on www.steelcase.com.

Electronic Catalog

Accurate sales quotations and purchase orders for Turnstone products are created with specification software that uses Turnstone Electronic Catalog data. Use the data to specify and price style numbers and options for every Turnstone product. The data is updated bimonthly by Steelcase and provided to software programs like the Hedberg Business System, 20-20 CAP Studio.

Furniture Symbol Graphic Data

Steelcase creates 2D and 3D furniture symbols (with attributes) for planning and initially specifying Steelcase products. This data is incorporated into several add-on software packages that work in either a Microstation or an AutoCAD drafting environment.

For more information about these and other software tools to help you plan effective work environments, please email fsl@steelcase.com

Steelcase

Product Info

Product Info

Electronic versions of this and many other specification guides in Acrobat PDF (Portable Document Format) allow you to scan, search, and print any page on virtually any computer. You can access these files at the Steelcase.com Web site or My Sales Online at www.in2.Steelcase.com.

Support

Steelcase Capabilities

Steelcase products are distributed, installed, and serviced through a network of more than 600 dealers worldwide. Steelcase is also represented with offices and corporate showrooms in 26 U.S. cities, 4 Canadian cities, and in France, Germany, Great Britain, and Japan. Every Steelcase product meets our exceptionally high standards of quality and durability and comes with the Steelcase assurance of excellence in service.

For assistance, please call your local dealer, the Steelcase Solutions Resource Team, or the Steelcase Solutions Fulfillment Team at 1.800.TURNSTONE (1.800.887.6786).

Call the Steelcase Solutions Fulfillment Team if you have submitted an order to Steelcase and you need to speak to your Solutions Fulfillment Team Representative about the order. Also call if you have any post-shipment quality or warranty concerns or service parts questions.

Outside the U.S.A., Canada, Mexico, Puerto Rico, and the U.S. Virgin Islands, call 1.616.247.2500.





Statement of Line	6
--------------------------	----------



Product Details

Application Guidelines	10
Building with Bivi	11
Tables	12
Cable Trough	14
Electrical Components	16
Storage	20
Rumble Seat and Hoodie	22
Components and Accessories	24



Specifying

Tables	25
Turnstone Tables	29
Electrical Components	30
Storage	33
Rumble Seat and Hoodie	34
Components and Accessories	36



Surface Materials	39
--------------------------	-----------

Statement of Line

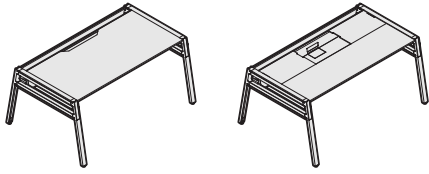

Understanding
 ▶ Pages 12-13
 Specifying
 ▶ Pages 25-26

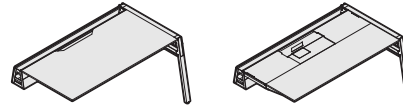

Understanding
 ▶ Pages 12-13
 Specifying
 ▶ Pages 25-26

Table for One

	D	W
Table	42 ¹ / ₄ "	62"
Table with Back Pocket	42 ¹ / ₄ "	62"

Table Plus One

	D	W
Table Plus One	42 ¹ / ₄ "	60"
Table Plus One with Back Pocket	42 ¹ / ₄ "	60"

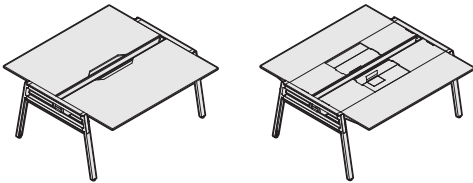

Understanding
 ▶ Pages 12-13
 Specifying
 ▶ Pages 27-28

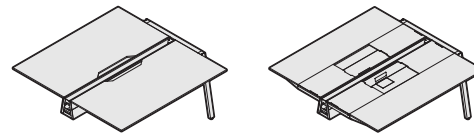

Understanding
 ▶ Pages 12-13
 Specifying
 ▶ Pages 27-28

Table for Two

	D	W
Table for Two	60"	62"
Table for Two with Back Pockets	60"	62"

Table Plus Two

	D	W
Table Plus Two	60"	60"
Table Plus Two with Back Pockets	60"	60"

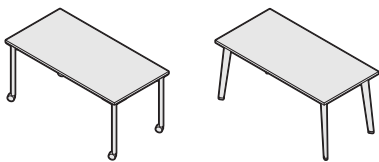

Understanding
 ▶ Pages 12-13
 Specifying
 ▶ Page 29



Understanding
 ▶ Pages 12-13
 Specifying
 ▶ Page 36

Turnstone Tables

60"W	
30"D	●

Half-Round Table Top

60"W	
27"D	●

Electrical Components

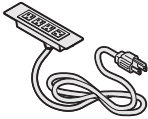

Plug and Play Power Kit - Package of One

Understanding
▶ Pages 16-19
Specifying
▶ Page 30

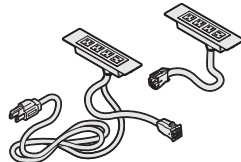

Plug and Play Power Kit - Package of Two

Understanding
▶ Pages 16-19
Specifying
▶ Page 30

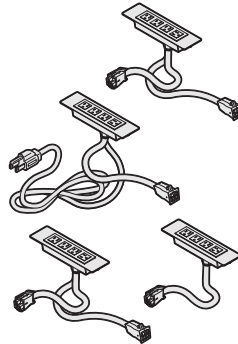

Plug and Play Power Kit - Package of Four

Understanding
▶ Pages 16-19
Specifying
▶ Page 30

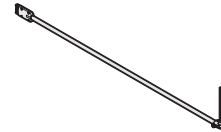

Hardwired Base Power-In

Understanding
▶ Pages 16-19
Specifying
▶ Page 31

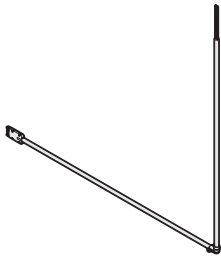

Hardwired Base Power-In, San Francisco

Understanding
▶ Pages 16-19
Specifying
▶ Page 31

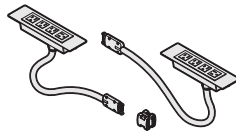

Accessory Powerways

Understanding
▶ Pages 16-19
Specifying
▶ Page 32

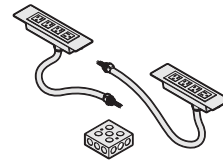

Chicago Accessory Powerway

Understanding
▶ Pages 16-19
Specifying
▶ Page 32

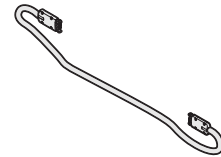
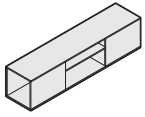

Table-to-Table Power Connector

Understanding
▶ Pages 16-19
Specifying
▶ Page 32

Statement of Line, continued



Understanding
 ▶ Pages 20-21
 Specifying
 ▶ Page 33

Trunk

	16"W
14"D	●

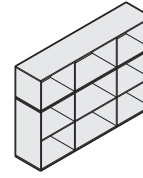
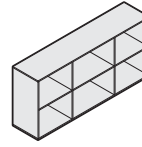
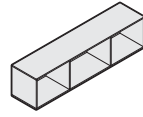

Understanding
 ▶ Pages 20-21
 Specifying
 ▶ Page 33

Depot

	15"H	28 1/2"H	42"H
13 7/8"D	●	●	●

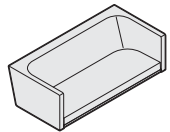

Understanding
 ▶ Pages 22–23
 Specifying
 ▶ Page 34

Rumble Seat (with or without exposed bracket)

D	W	H
28"	58"	16"

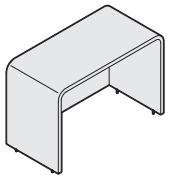

Understanding
 ▶ Pages 22–23
 Specifying
 ▶ Page 35

Hoodie

D	W	H
28"	58"	38 1/8"

Components

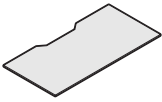

Table Top
Understanding
▶ Page 24
Specifying
▶ Page 36

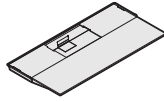

Table Top with Back Pocket
Understanding
▶ Page 24
Specifying
▶ Page 36



Leg
Understanding
▶ Page 24
Specifying
▶ Page 37



Pocket Cover
Understanding
▶ Page 24
Specifying
▶ Page 37

Accessories



Top Shelf
Understanding
▶ Page 24
Specifying
▶ Page 37



Bottom Shelf
Understanding
▶ Page 24
Specifying
▶ Page 38



Hook
Understanding
▶ Page 24
Specifying
▶ Page 38

Application Guidelines



Bivi Table for One and a Table Plus One can be attached with users sitting next to or across from each other.

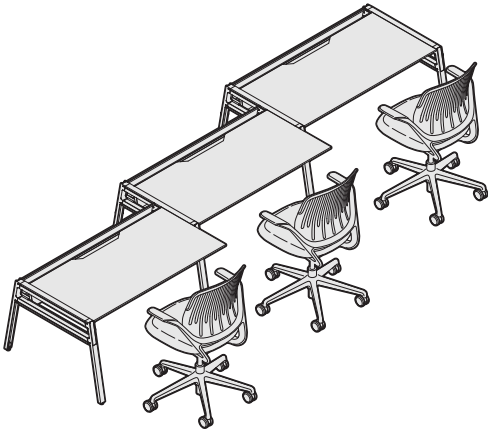

Bivi Table for One and a Table Plus One can be connected off-set, creating a staircase application.

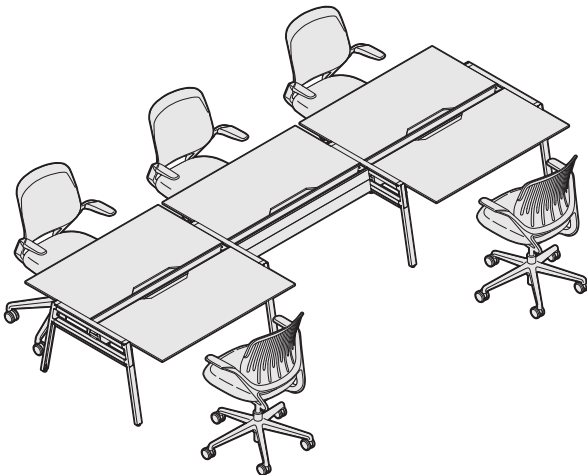

When an architectural obstruction such as a column occurs, one table top can be left off.

Bivi Table for Two and Half-Round Table Tops create a conference table for six.

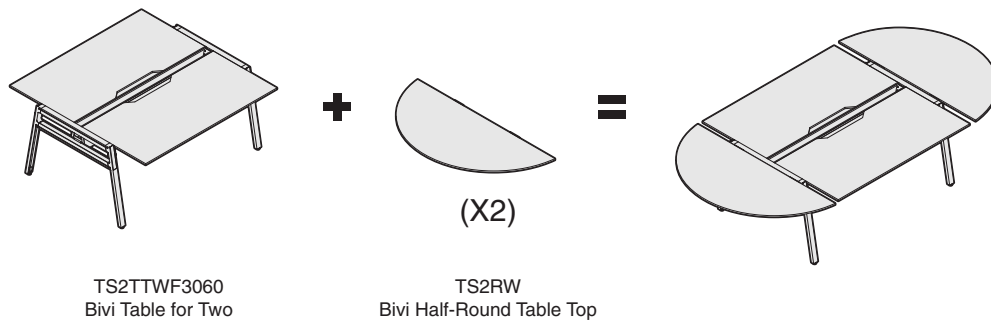

Bivi Table for One and Table Plus One connect to make a team space. If reconfiguration is desired, one option would be to order an additional Bivi Leg and separate into individual tables.

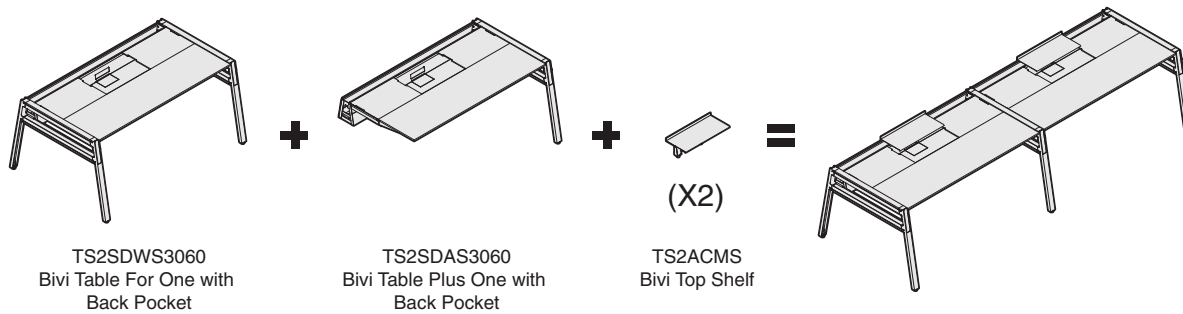

Bivi Table for Two and Table Plus Two come with either two Table Tops or two Table Tops with Back Pockets. In order to create a combination shown below, use a Bivi Table Plus One and an extra Table Top.

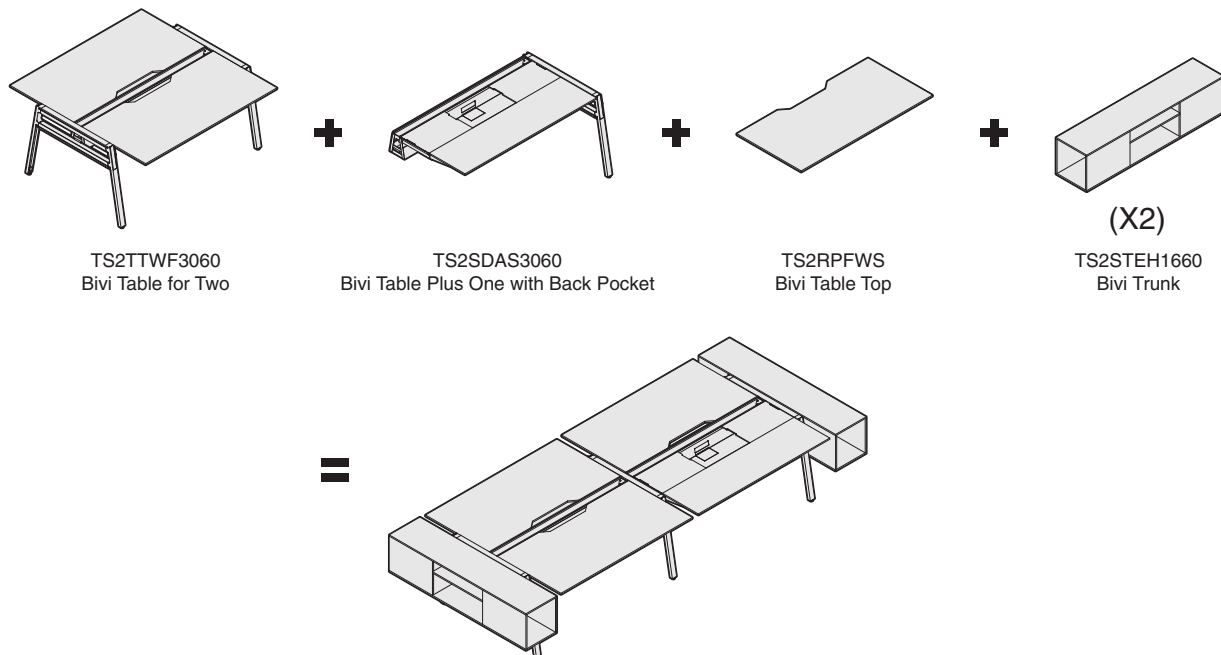

Tables

Table for One, Table Plus One, Table for Two, Table Plus Two, and Turnstone Tables Overview

Bivi Table for One comes standard with a cable trough, two legs, and a full table top or a table top with a back pocket. Bivi Table Plus One comes standard with a cable trough, one leg and a full table top or a table top with a back pocket.
 ▶ Specifying, page 25

Bivi Table for Two comes standard with a cable trough, two legs, and two full table tops or table tops with a back pocket. Bivi Table Plus Two comes standard with a cable trough, one leg, and two full table tops or table tops with a back pocket.
 ▶ Specifying, page 27

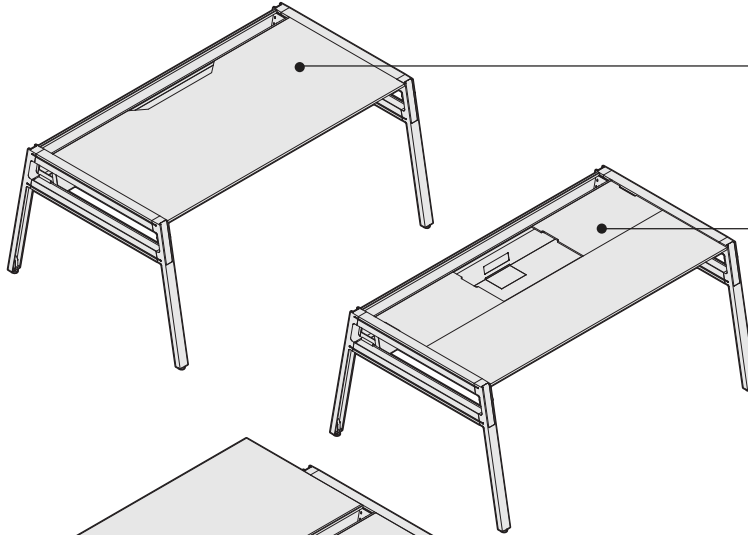
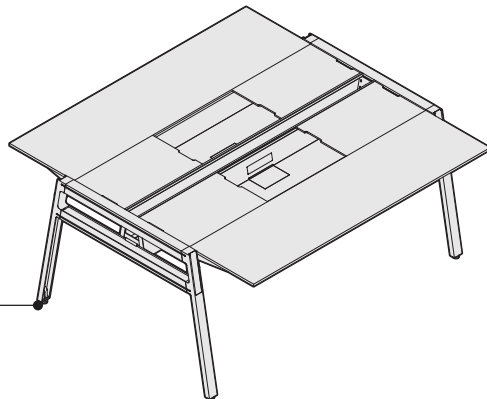
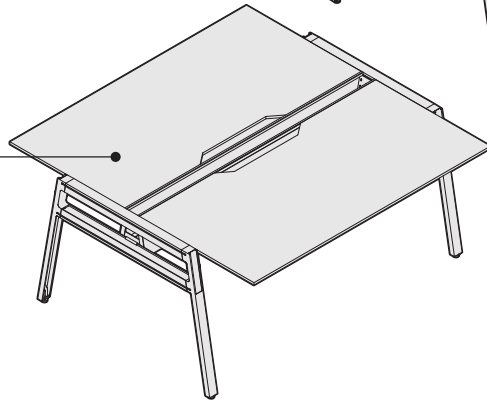

Table top is 1/2" thick with edge to laminate color.

Two pocket covers match the laminate table top and conceal two-thirds of the back pocket allowing the pocket covers to slide side-to-side to access stored items.

Height of worksurface to floor is 28 1/2".



Leveling glides have 1 1/2" adjustability range to install tables on uneven floors.

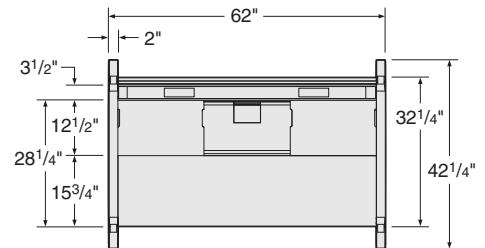

Table for One

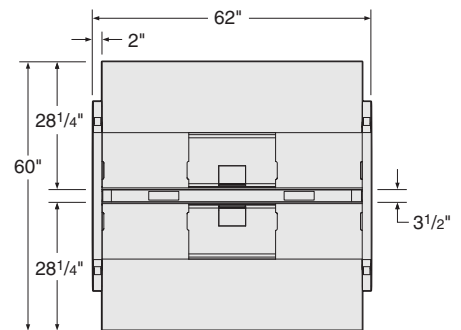
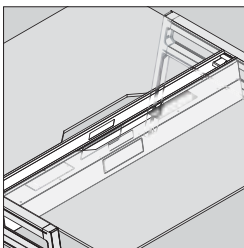

Table for Two

Actual Dimensions

	Table for One	Table Plus One	Table for Two	Table Plus Two
Depth	42 1/4"	42 1/4"	60"	60"
Width	62"	60"	62"	62"
Height	28 1/2"	28 1/2"	28 1/2"	28 1/2"
Worksurface Thickness	1/2"	1/2"	1/2"	1/2"

Product Details



Cable troughs are used to hold power, wires, and blocks. Each cable trough has four areas for power. Two areas are in the center of the trough and one on each side. The power locations on the side of the cable trough have knockouts that can be removed if power in these locations is desired.

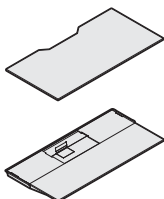

Bivi tables have two types of tops. Table top has a full depth top. Table top with back pocket has a half depth top and the back pocket has an area for storage. Table top with back pocket comes with two pocket covers. The Bivi table top and the table top with back pocket can be ordered as separate components.

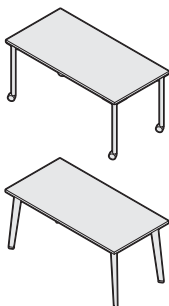

Turnstone tables come standard with a set of four post legs and casters (two locking) or with four tapered legs.

Connections

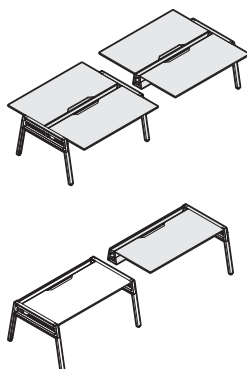

Plus tables come with one leg and adjustable glides with a 1 1/2" range. Tables can be connected to an existing table in order to create a benching application. Two tables share one leg.

Electrical

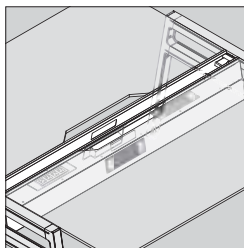

Access for power is located in four areas of the cable trough. Two in the center of the trough and one on each side of the trough.

Accessory powerways, TS2P260, can have a maximum of six powerways connected per one hardwired base power-in, TS2PBT2 or TS2PBT2SF for a maximum of 48 plugs.

Weight Capacities

Table for One: 200 lbs.

Table for One with back pocket, split table top: 200 lbs. and back pocket: 40 lbs.

Table for Two: 400 lbs.

Surface Materials

Table tops
• Laminate

Pocket covers
• Laminate

Legs, cable trough, and back pocket
• Paint

Cable Trough

Data ports can also be set in the bottom half or the top half of the trough and accessed through the various cable routing openings.

The top half of the trough holds power strips and manages personal cords such as a phone charger, ipod, or laptop cords.

The openings on the side of the trough and the end of each trough are for routing cables in and out of the trough.

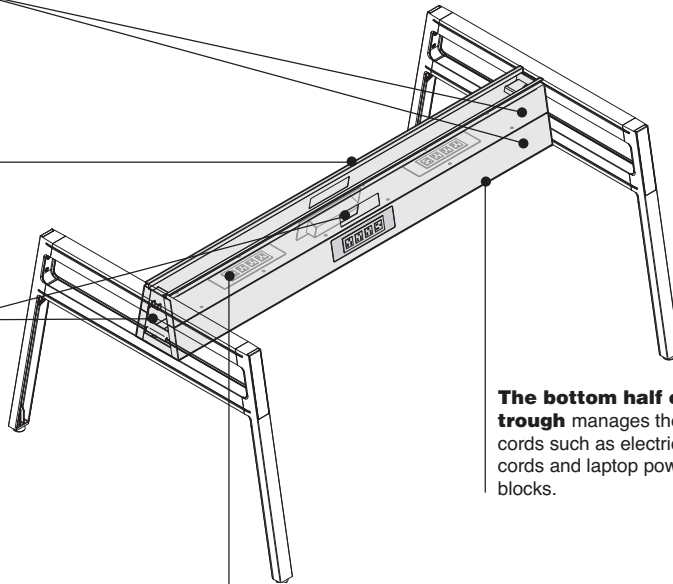

The bottom half of the trough manages the bigger cords such as electrical cords and laptop power blocks.

The trough has two openings for power in the center of the trough. There are trough cover plates (TS2CTFCSR, package of two) available if you do not choose to use both or either of these locations.

Product Details

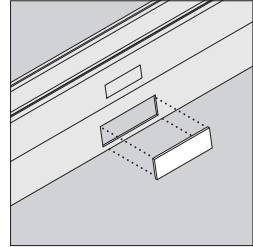

A perforated metal rectangle located at both sides of the trough can be knocked out to gain access to power if power is installed at the side of the trough. Once removed, the opening is permanent. There are no fillers available for this location.

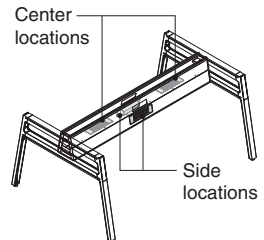

If both locations in the center and both locations in the side of the trough are used for power, there is a total of four power strips available in one trough. A package of four (TS2PS4PK), ordered separately, would allow a total of 16 plugs.

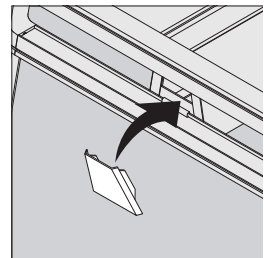

A trough end cover (TS2CTECSR, package of two) is available if closed end is preferred.

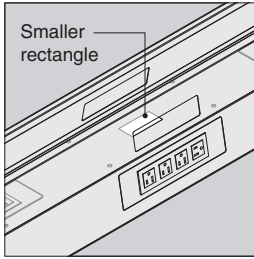

Surface Materials

- Paint

The smaller perforated metal rectangle is a standard size that fits most data faceplates. Once removed, the opening is permanent. There are no fillers for this location.

Electrical Components

Bivi electrical components are simple and easy to install. Power kits and hardwired powerways can be installed in the cable trough, which provides easy access.

► Specifying, page 30

Bivi power kits and hardwired powerways are waterproof to prevent electrical shorts.

Knockouts are located on each side of the trough. knockouts can be removed and power strips installed for access to power from the side of the trough.

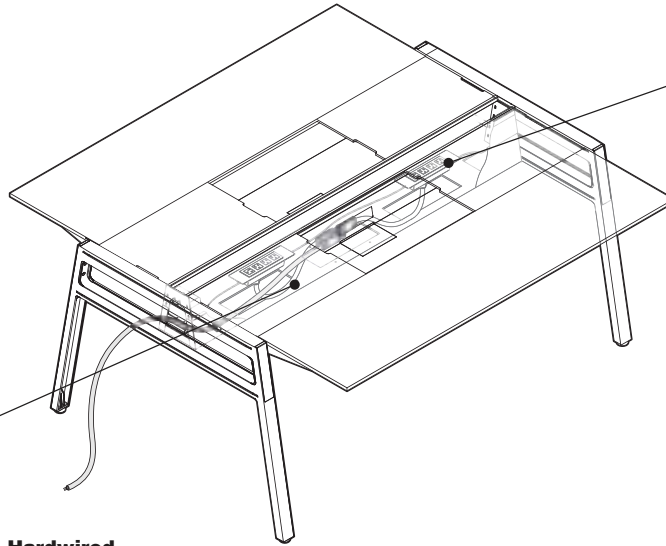

Hardwired

Hardwired powerways, TS2P260 and TS2P2CHI, have two sections with four receptacles each for a total of eight receptacles.

Steelcase products are designed and tested for code and standard compliance when installed and used as an integrated product solution in accordance with Steelcase application guidelines and installation instructions. However, the building owner or designated agent is responsible for verifying that the installation is in compliance with local codes and regulations.

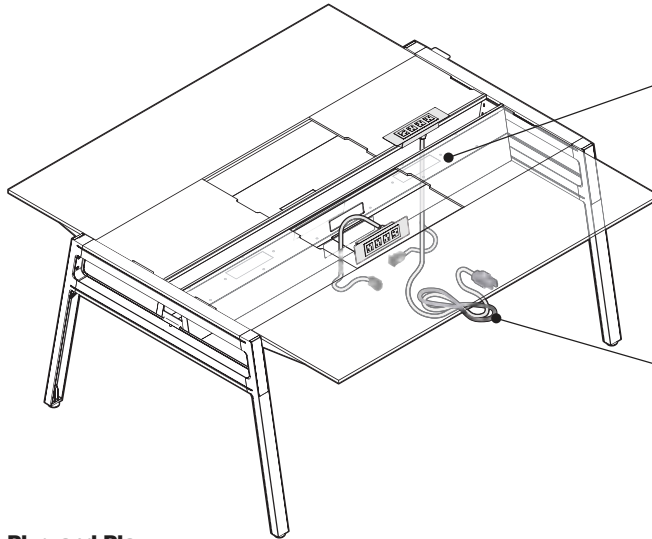

Plug and Play

Plug and play power kit package of two, TS2PS2PK, has two sections with four receptacles each for a total of eight receptacles.

Plug and play power kit package of four, TS2PS4PK, has four sections with four receptacles each for a total of 16 receptacles.

Plug and play power kits have a 15-amp 10' cord that plugs into a building receptacle.

Product Details

Two-pack and four-pack power strips do not connect together as this would cause a potential power failure and hazard. Power strips must plug into an individual power source.

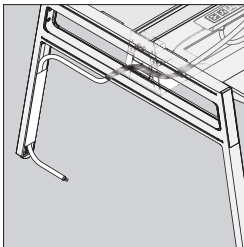
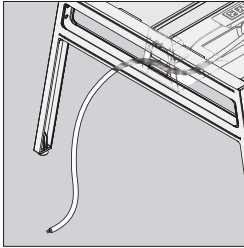

Bivi hardwired modular power has 22" length of conduit from the point of coming straight out of the table and 9" if using the leg cover (TS2LEGCVRSR, package of two) wire management solution.

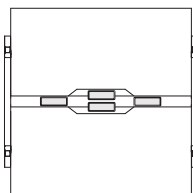

Table-to-table connectors are used when connecting power between two Bivi tables or when two hardwired powerways are used in one Bivi table.

Power Specifications

- Single circuit power
- 12-amp system rating
- 15-amp power cord with 15-amp over-current protection
- UL recognized Powered Table System component per UL962

Surface Materials

- Power strips**
- Paint

Power Routing Chart

Powerways have 5' of conduit between receptacle strips, that gives room to share power between multiple tables in some applications. 2-Pack plug-in power kits are color coded and connect into each other.

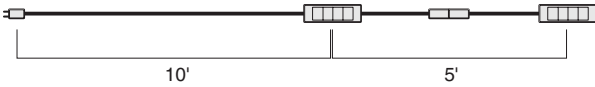

4-Pack plug and play power kits are color coded and connect into each other.

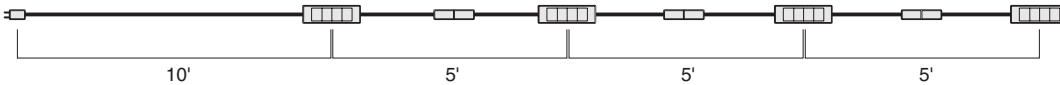

2-Pack plug and play power kits have maximum of one connection point. 4-Pack plug and play power kits have maximum of three connection points. Chicago has a unique powerway, see specifying page 32. San Francisco has a unique hardwire base power-in, see specifying page 31.

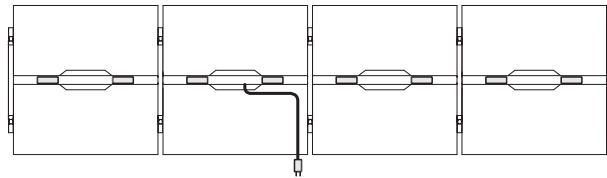

Bivi tables do not have maximum table limit. An unlimited amount of tables can be connected together. Power will need to be plugged into a building outlet in the middle of runs when multiple tables are connected and power is used.

Bivi Power Routing Guide

	Plugs Per Person	Plug and Play Power Examples	Hardwired Power Examples (require authorized electrician)
	(1) Table for One 4 plugs per person	(1) Package of One, TS2PS1PK	N.A.
	(1) Table for One 8 plugs per person	(1) Package of Two, TS2PS2PK	(1) Powerway, Two Circuit, TS2P260 (1) Base Power-In, Hardwired, 2-circuit, TS2PBT2
	(1) Table for Two 4 plugs per person	(1) Package of Two, TS2PS2PK	(1) Powerway, Two Circuit, TS2P260 (1) Base Power-In, Hardwired, 2-circuit, TS2PBT2
	(1) Table for Two 8 plugs per person	(1) Package of Four, TS2PS4PK	(2) Powerway, Two Circuit, TS2P260 (1) Table-to-Table Connector, TS2PT2T (1) Base Power-In, Hardwired, 2-circuit, TS2PBT2

Bivi Power Routing Guide, continued

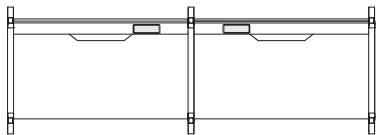
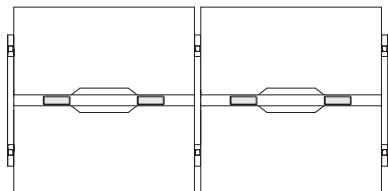
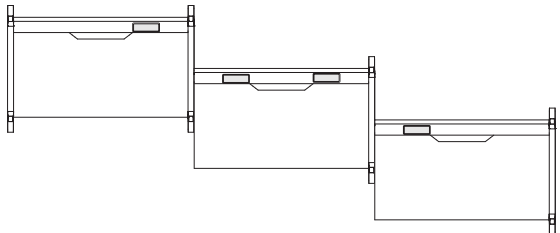
	Plugs Per Person	Plug and Play Power Examples	Hardwired Power Examples (require authorized electrician)
	(1) Table for One (1) Table Plus One 4 plugs per person	(1) Package of Two, TS2PS2PK	(1) Powerway, Two Circuit, TS2P260 (1) Base Power-In, Hardwired, 2-circuit, TS2PBT2
	(1) Table for Two (1) Table Plus Two 4 plugs per person	(1) Package of Four, TS2PS4PK	(2) Powerway, Two Circuit, TS2P260 (1) Table-to-Table Connector, TS2PT2T (1) Base Power-In, Hardwired, 2-circuit, TS2PBT2
	(1) Table for One (2) Table Plus One 4 plugs for two people 8 plugs for one person	(1) Package of Four, TS2PS4PK	(2) Powerway, Two Circuit, TS2P260 (2) Table-to-Table Connector, TS2PT2T (1) Base Power-In, Hardwired, 2-circuit, TS2PBT2

Note: In order to share hardwired powerways between two (2) tables in a stairstep application connectors are required.

Openings can be skipped to stretch out the power to more users. There is 5' of cord length between power strips which allows this.

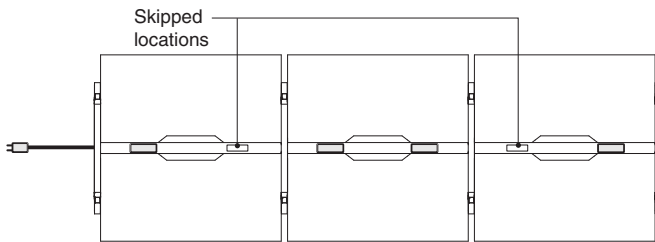

Six Person Example

Provides two (2) plugs per person at the table for two at each end and four (4) plugs per person at the table for two in the middle of the setting. Requires quantity of one (1) package of four (TS2PS4PK) and one (1) building outlet to power up table.

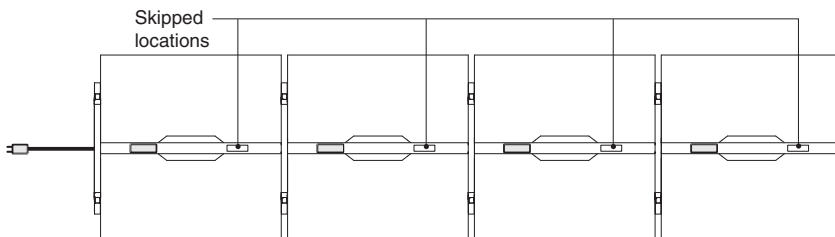

Eight Person Example

Provides two (2) plugs per person. Requires quantity of one (1) package of four (TS2PS4PK) and one (1) building outlet to power up table.

Storage

Trunk storage attaches to the end of a Bivi Table for Two. It has storage on each end as well as additional storage in the middle. Trunk is not approved to be used in a freestanding application or in a wall mount application.
 ▶ Specifying, page 33

Depot storage is free-standing and comes in one-high, two-high, or three-high. Depot is not approved to be stacked on top of each other and cannot be wall mounted.

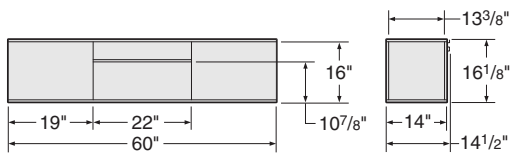
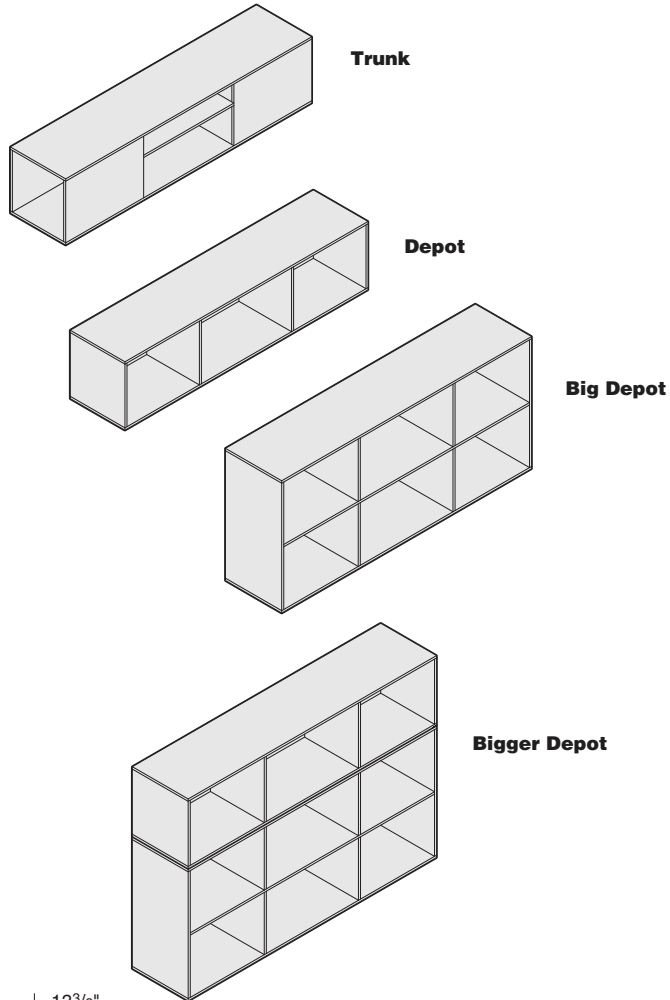

Trunk

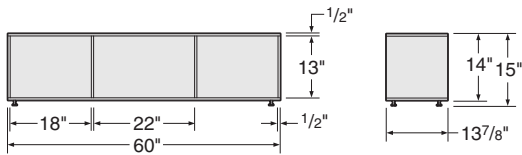

Depot

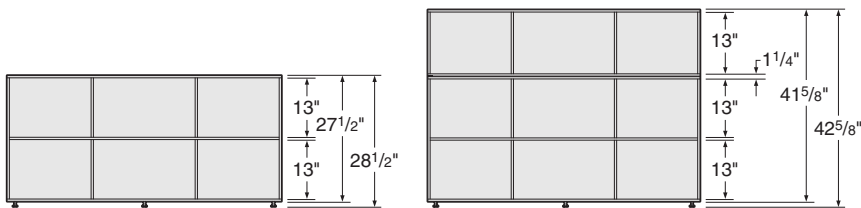

Big Depot

Bigger Depot

Product Details

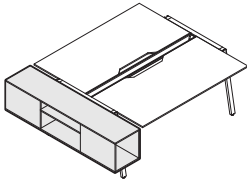

Trunk storage attaches to the end of a Bivi Table for Two. It has storage on each end as well as additional storage in the middle.

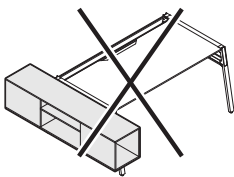

Trunk cannot be used on a Bivi Table for One.

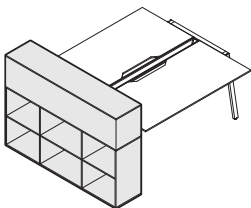
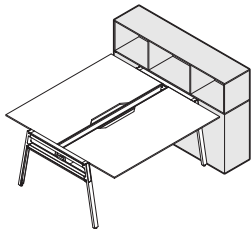

Bigger Depot has the ability to turn the top section around so it faces the table top when placed against the end of the Bivi table.

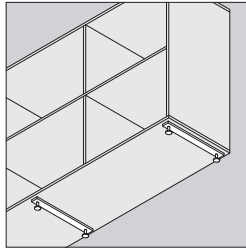

Depot storage comes with feet and adjustable glides on each end. Big Depot and Bigger Depot also come with an additional foot with adjustable glides in the center as well.

Weight Capacities

Trunk: 200 lbs. on top, 50 lbs. per cubby, and 25 lbs. per shelf.

Depots: 200 lbs. on top (all sizes) and 50 lbs. per cubby (all sizes).

Surface Materials

Trunk and Depot storage

- Laminate

Trunk shelves

- Paint

Rumble Seat and Hoodie

Rumble Seat comes with table frame attachment brackets. Available in single fabric option for back and seat and Cal TB 133 Fire Code Seating.
 ▶ Specifying, page 34

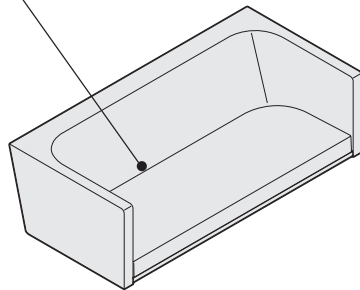

Hoodie is standard with attachment hardware to connect to a Rumble Seat. Available in a single fabric option for the top and sides and a default mesh on the back panel.
 ▶ Specifying, page 35

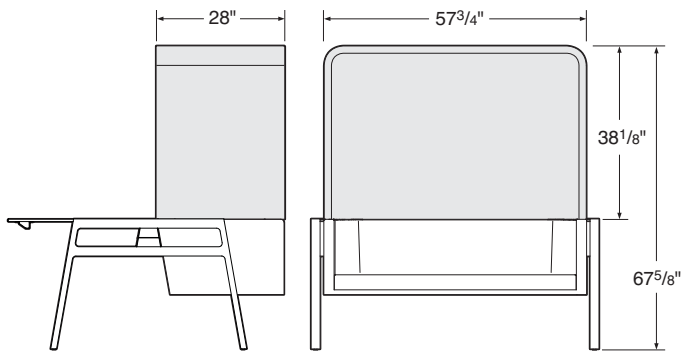
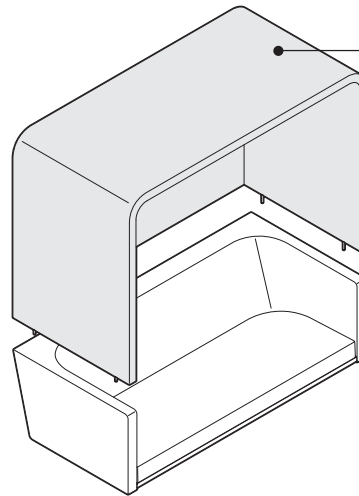

Hoodie

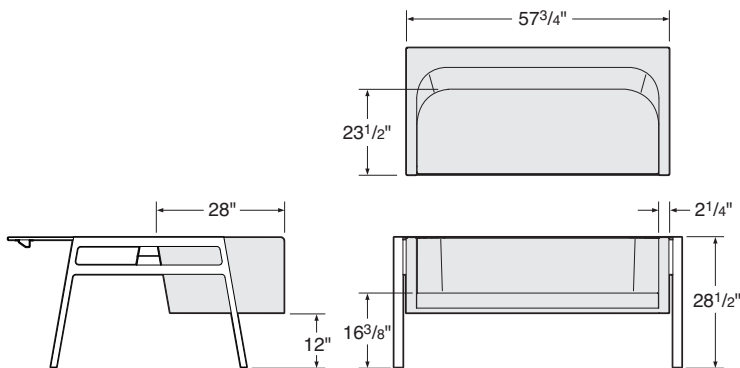

Rumble Seat

Actual Dimensions

	Rumble Seat with table frame attachment brackets	Hoodie	Rumble Seat with Hoodie
Height	28 1/2"	38 1/8"	67 5/8"
Seat Height	16 3/8"	N.A.	N.A.
Depth	28"	28"	28"
Seat Depth	23 1/2"	N.A.	N.A.
Width	57 3/4"	57 3/4"	58"

Product Details

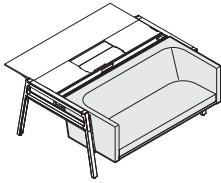

Rumble Seats can be installed on one or both sides of a Bivi Table for Two.

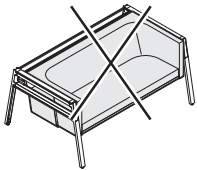

Rumble Seats cannot be installed in place of a work-surface on a Bivi Table for One.

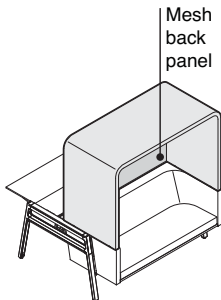

Hoodie is only intended to be used attached to a Rumble Seat.

Hoodie comes with two fabric options for the sides and top.

Back panel on Hoodie is defaulted in mesh. Mesh material used on the Hoodie back panel offers semi-transparency.

Connections

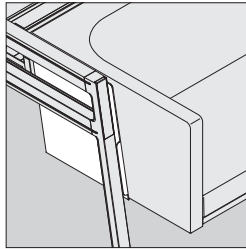
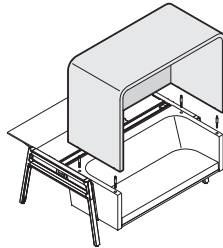

Table frame attachment brackets connect the Rumble Seat to the table frame in place of a table top on a Bivi Table for Two.



Rumble Seats have connectors that come standard to attach the Hoodie. These connectors need to be located and cut to expose them in order to attach the Hoodie. If you know ahead of time that a Hoodie will be installed, there is a style number that supports the Rumble Seat with the connectors exposed from the factory, TS3RSBKT.

Surface Materials

Rumble Seats
• Fabric

Table frame attachment brackets
• Paint

Hoodie
• Fabric
• Mesh: T615 Sultry Smoke

Components and Accessories

Half-round table top attaches to the end of a Bivi table.
 ▶ Specifying, page 36

Pocket covers are laminate and can be ordered separately in order to enclose a back pocket. Each back pocket comes with two pocket covers that cover two thirds of the back pocket leaving one third of the opening to allow the pocket covers to slide side-to-side for easy access to stored items. Adding a third cover makes the appearance of a full table top.

Bottom shelf attaches to the leg of a Bivi table. The bottom shelf can hold a CPU, backpack, computer bag, and other small items.

Hooks attach to the leg of a Bivi table either under the desk or on the outside. Hooks come in two-packs or four-packs.

Bivi leg is available to order separately for reconfiguration purposes. In an existing benching application, you can take apart the table and add a leg to create two freestanding tables.

Adding a half-round table top at the ends of a Bivi Table for Two creates a conference table.

Top shelf attaches to the cable trough. Three top shelves can span across a Bivi Table for One; up to six top shelves can be used on a Bivi Table for Two.

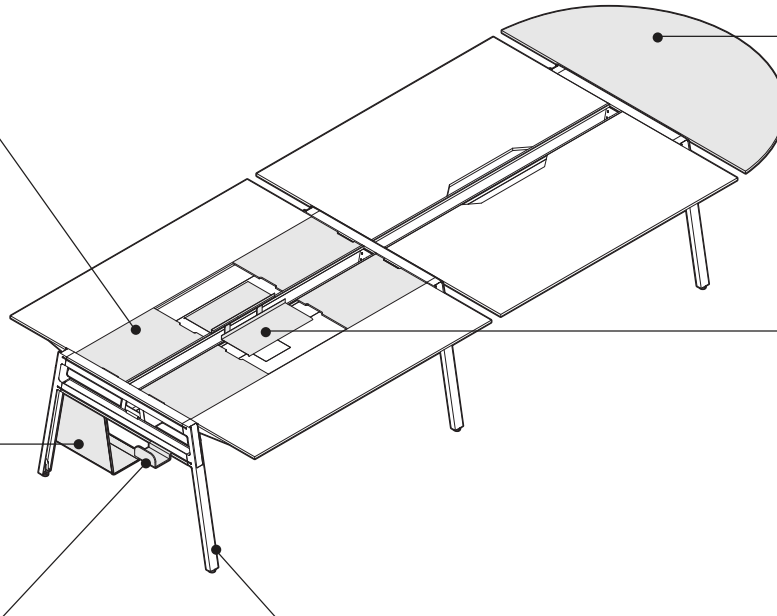

Weight Capacities

Half Round Table Top	200 lbs.
Hook	25 lbs.
Top Shelf	30 lbs.
Bottom Shelf	30 lbs.

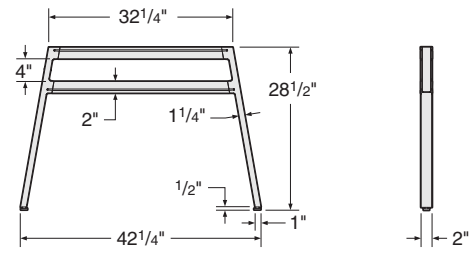

Tables

Table for One

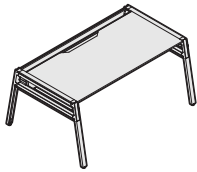

Tip: Bivi tables require assembly.

Standard Includes	Required to Specify
-------------------	---------------------

<ul style="list-style-type: none"> ▶ Need help? Product details, page 12 • 1/2"-thick table top: Low-Pressure Laminate • Edge band: default color to match laminate • Two legs: paint • Cable trough: paint 	<ol style="list-style-type: none"> 1 Style number 2 Low-Pressure Laminate color number for table top 3 Paint color number for legs and cable trough 4 Options, if selected (see below) <p>▶ See <i>Surface Materials</i>, page 39.</p>
--	--

Options	U.S. Price	Required to Specify
---------	------------	---------------------

Power Kits <ul style="list-style-type: none"> • Package of two plug and play power kits • Package of four plug and play power kits 	<ul style="list-style-type: none"> +\$413 +\$761 	Specify with <i>package of two plug and play power kits</i> and select paint color number. Specify with <i>package of four plug and play power kits</i> and select paint color number.
---	--	--

Specification Information				
Dimensions			Style Number	U.S. Base Price
D	W	H		

42 1/4"	62"	28 1/2"	TS2SDWF3060	\$1172
---------	-----	---------	--------------------	--------

Table Plus One

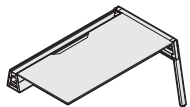

Tip: Bivi tables require assembly.

Tip: Table Plus One must attach to another Bivi table for stability.

Standard Includes	Required to Specify
-------------------	---------------------

<ul style="list-style-type: none"> ▶ Need help? Product details, page 12 • 1/2"-thick table top: Low-Pressure Laminate • Edge band: default color to match laminate • One leg: paint • Cable trough: paint 	<ol style="list-style-type: none"> 1 Style number 2 Low-Pressure Laminate color number for table top 3 Paint color number for leg and cable trough 4 Options, if selected (see below) <p>▶ See <i>Surface Materials</i>, page 39.</p>
---	---

Options	U.S. Price	Required to Specify
---------	------------	---------------------

Power Kits <ul style="list-style-type: none"> • Package of two plug and play power kits • Package of four plug and play power kits 	<ul style="list-style-type: none"> +\$413 +\$761 	Specify with <i>package of two plug and play power kits</i> and select paint color number. Specify with <i>package of four plug and play power kits</i> and select paint color number.
---	--	--

Specification Information				
Dimensions			Style Number	U.S. Base Price
D	W	H		

42 1/4"	60"	28 1/2"	TS2SDAF3060	\$998
---------	-----	---------	--------------------	-------



For Canadian Pricing

Multiply U.S. Price by the Canadian price factor.

▶ See page 1 for details.

Table for One with Back Pocket

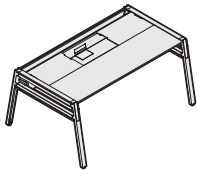

Tip: Bivi tables require assembly.

Standard Includes		Required to Specify
<ul style="list-style-type: none"> ▶ Need help? Product details, page 12 	<ul style="list-style-type: none"> • 1/2"-thick table top: Low-Pressure Laminate • Edge band: default color to match laminate • Two legs: paint • Cable trough: paint • Back pocket: paint • Two pocket covers: Low-Pressure Laminate 	<ol style="list-style-type: none"> 1 Style number 2 Low-Pressure Laminate color number for table top and pocket covers 3 Paint color number for legs, back pocket, and cable trough 4 Options, if selected (see below) <p>▶ See <i>Surface Materials</i>, page 39.</p>

Options	U.S. Price	Required to Specify
Power Kits <ul style="list-style-type: none"> • Package of two plug and play power kits • Package of four plug and play power kits 	+\$413 +\$761	Specify with <i>package of two plug and play power kits</i> and select paint color number. Specify with <i>package of four plug and play power kits</i> and select paint color number.

Specification Information				
Dimensions			Style Number	U.S. Base Price
D	W	H		
42 1/4"	62"	28 1/2"	TS2SDWS3060	\$1389

Table Plus One with Back Pocket

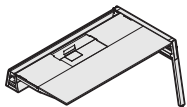

Tip: Bivi tables require assembly.

Standard Includes		Required to Specify
<ul style="list-style-type: none"> ▶ Need help? Product details, page 12 	<ul style="list-style-type: none"> • 1/2"-thick table top: Low-Pressure Laminate • Edge band: default color to match laminate • One leg: paint • Cable trough: paint • Back pocket: paint • Two pocket covers: Low-Pressure Laminate 	<ol style="list-style-type: none"> 1 Style number 2 Low-Pressure Laminate color number for table top and pocket covers 3 Paint color number for leg, back pocket, and cable trough 4 Options, if selected (see below) <p>▶ See <i>Surface Materials</i>, page 39.</p>

Options	U.S. Price	Required to Specify
Power Kits <ul style="list-style-type: none"> • Package of two plug and play power kits • Package of four plug and play power kits 	+\$413 +\$761	Specify with <i>package of two plug and play power kits</i> and select paint color number. Specify with <i>package of four plug and play power kits</i> and select paint color number.

Specification Information				
Dimensions			Style Number	U.S. Base Price
D	W	H		
42 1/4"	60"	28 1/2"	TS2SDAS3060	\$1215

 **For Canadian Pricing**
 Multiply U.S. Price by the Canadian price factor.
 ▶ See page 1 for details.

Table for Two

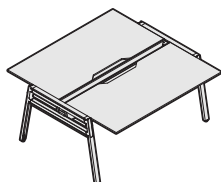

Tip: Bivi tables require assembly.

Standard Includes		Required to Specify
-------------------	--	---------------------

<ul style="list-style-type: none"> ▶ Need help? Product details, page 12 	<ul style="list-style-type: none"> • Two, 1/2"-thick table tops: Low-Pressure Laminate • Edge band: default color to match laminate • Two legs: paint • Cable trough: paint 	<ol style="list-style-type: none"> 1 Style number 2 Low-Pressure Laminate color number for table tops 3 Paint color number for legs and cable trough 4 Options, if selected (see below) <ul style="list-style-type: none"> ▶ See <i>Surface Materials</i>, page 39.
---	---	--

Options	U.S. Price	Required to Specify
---------	------------	---------------------

Power Kits <ul style="list-style-type: none"> • Package of two plug and play power kits • Package of four plug and play power kits 	+\$413 +\$761	Specify with <i>package of two plug and play power kits</i> and select paint color number. Specify with <i>package of four plug and play power kits</i> and select paint color number.
---	------------------	---

Specification Information

Dimensions			Style Number	U.S. Base Price
D	W	H		
60"	62"	28 1/2"	TS2TTWF3060	\$1658

Table Plus Two

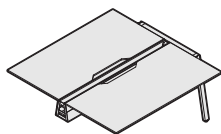

Tip: Bivi tables require assembly.

Tip: Table Plus Two must attach to another Bivi table for stability.

Standard Includes		Required to Specify
-------------------	--	---------------------

<ul style="list-style-type: none"> ▶ Need help? Product details, page 12 	<ul style="list-style-type: none"> • Two, 1/2"-thick table tops: Low-Pressure Laminate • Edge band: default color to match laminate • One leg: paint • Cable trough: paint 	<ol style="list-style-type: none"> 1 Style number 2 Low-Pressure Laminate color number for table top 3 Paint color number for leg and cable trough 4 Options, if selected (see below) <ul style="list-style-type: none"> ▶ See <i>Surface Materials</i>, page 39.
---	--	--

Options	U.S. Price	Required to Specify
---------	------------	---------------------

Power Kits <ul style="list-style-type: none"> • Package of two plug and play power kits • Package of four plug and play power kits 	+\$413 +\$761	Specify with <i>package of two plug and play power kits</i> and select paint color number. Specify with <i>package of four plug and play power kits</i> and select paint color number.
---	------------------	---

Specification Information

Dimensions			Style Number	U.S. Base Price
D	W	H		
60"	60"	28 1/2"	TS2TTAF3060	\$1498



For Canadian Pricing

Multiply U.S. Price by the Canadian price factor.

▶ See page 1 for details.

Table for Two with Back Pockets

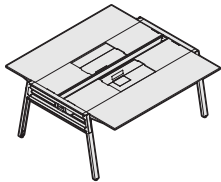

Tip: Bivi tables require assembly.

Standard Includes		Required to Specify
-------------------	--	---------------------

- | | | |
|---|---|--|
| <ul style="list-style-type: none"> ▶ Need help? Product details, page 12 | <ul style="list-style-type: none"> • Two, 1/2"-thick table tops: Low-Pressure Laminate • Edge band: default color to match laminate • Two legs: paint • Cable trough: paint • Two back pockets: paint • Four pocket covers: Low-Pressure Laminate | <ol style="list-style-type: none"> 1 Style number 2 Low-Pressure Laminate color number for table tops and pocket covers 3 Paint color number for legs, back pockets, and cable trough 4 Options, if selected (see below) <p>▶ See <i>Surface Materials</i>, page 39.</p> |
|---|---|--|

Options	U.S. Price	Required to Specify
---------	------------	---------------------

- | | | |
|--|-----------------------------|--|
| <p>Power Kits</p> <ul style="list-style-type: none"> • Package of two plug and play power kits • Package of four plug and play power kits | <p>+\$413</p> <p>+\$761</p> | <p>Specify with package of two plug and play power kits and select paint color number.</p> <p>Specify with package of four plug and play power kits and select paint color number.</p> |
|--|-----------------------------|--|

Specification Information

Dimensions			Style Number	U.S. Base Price
D	W	H		
60"	62"	28 1/2"	TS2TTWS3060	\$1998

Table Plus Two with Back Pockets

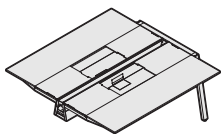

Tip: Bivi tables require assembly.

Tip: Bivi Table Plus Two with Back Pockets must attach to another Bivi table for stability.

Standard Includes		Required to Specify
-------------------	--	---------------------

- | | | |
|---|--|--|
| <ul style="list-style-type: none"> ▶ Need help? Product details, page 12 | <ul style="list-style-type: none"> • Two, 1/2"-thick table tops: Low-Pressure Laminate • Edge band: default color to match laminate • One leg: paint • Cable trough: paint • Two back pockets: paint • Four pocket covers: Low-Pressure Laminate | <ol style="list-style-type: none"> 1 Style number 2 Low-Pressure Laminate color number for table tops and pocket covers 3 Paint color number for leg, back pocket, and cable trough 4 Options, if selected (see below) <p>▶ See <i>Surface Materials</i>, page 39.</p> |
|---|--|--|

Options	U.S. Price	Required to Specify
---------	------------	---------------------

- | | | |
|--|-----------------------------|--|
| <p>Power Kits</p> <ul style="list-style-type: none"> • Package of two plug and play power kits • Package of four plug and play power kits | <p>+\$413</p> <p>+\$761</p> | <p>Specify with package of two plug and play power kits and select paint color number.</p> <p>Specify with package of four plug and play power kits and select paint color number.</p> |
|--|-----------------------------|--|

Specification Information

Dimensions			Style Number	U.S. Base Price
D	W	H		
60"	60"	28 1/2"	TS2TTAS3060	\$1838



For Canadian Pricing
 Multiply U.S. Price by the Canadian price factor.
 ▶ See page 1 for details.

Turnstone Tables

Tip: Turnstone tables require assembly.

Standard Includes		Required to Specify
<ul style="list-style-type: none"> ▶ Need help? Product details, page 12 	<ul style="list-style-type: none"> • 1"-thick table top: Low-Pressure Laminate • Edge band: default color to match laminate • Post legs or tapered legs: paint 	<ul style="list-style-type: none"> 1 Style number 2 Low-Pressure Laminate color number for table top 3 Paint color number for legs ▶ See <i>Surface Materials</i>, page 39.

Specification Information

Dimensions			Style	U.S.
D	W	H	Number	Price

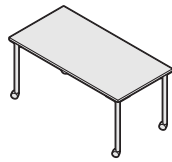

Table with Post Legs with Casters (two locking)

30"	60"	28 ¹ / ₂ "	TS2LD3060PS	\$636
-----	-----	----------------------------------	--------------------	-------

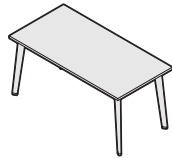

Table with Tapered Legs

30"	60"	28 ¹ / ₂ "	TS2LD3060TS	\$743
-----	-----	----------------------------------	--------------------	-------

 **For Canadian Pricing**
 Multiply U.S. Price by the Canadian price factor.
 ▶ See page 1 for details.

Electrical Components

Plug and Play Power Kits

Standard Includes	Required to Specify
<ul style="list-style-type: none"> ▶ Need help? Product details, page 16 • Power kit: paint • 12-amp system rating • 15-amp power cord with 15-amp over-current protection • 10' long cord with wall plug • 5' cord length between power strips • UL recognized Powered Table System Component per UL962 	<ul style="list-style-type: none"> 1 Style number 2 Paint color number for power kit ▶ See <i>Surface Materials</i>, page 39.

Specification Information		
• Total Receptacles	• Style Number	• U.S. Price

Package of One

4	TS2PS1PK	\$220

Package of Two

8	TS2PS2PK	\$413

Package of Four

16	TS2PS4PK	\$761

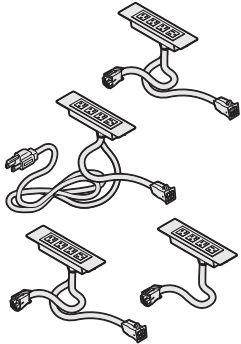
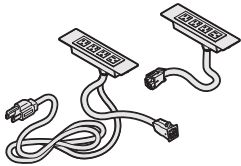
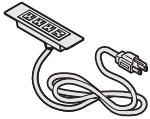

For Canadian Pricing
 Multiply U.S. Price by the Canadian price factor.
 ▶ See page 1 for details.

Accessory Base Power-Ins

	Standard Includes	Required to Specify
▶ Need help? Product details, page 16	<ul style="list-style-type: none"> • 2-circuit hardwired base power-in, 3/8" diameter flexible galvanized steel conduit, liquid tight conduit outside of trough • Modular connection for 2-circuit powerways • In-line connector to allow connection at middle of run • San Francisco hardwired base power-in, 3/8" diameter flexible galvanized steel conduit, liquid tight conduit outside of trough 	Style number

Specification Information

Style Number	U.S. Price

Accessory Base Power-In, Hardwired, Two Circuit, Line 1 and Line 2

TS2PBT2	\$124

Accessory Base Power-In, Hardwired, San Francisco, Two Circuit, Line 1 and Line 2

TS2PBT2SF	\$156

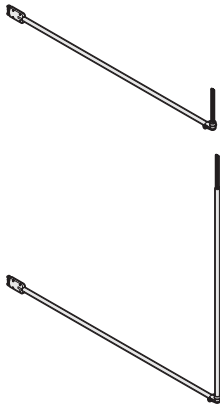

 **For Canadian Pricing**
 Multiply U.S. Price by the Canadian price factor.
 ▶ See page 1 for details.

Hardwired Powerways

	Standard Includes	Required to Specify
▶ Need help? Product details, page 16	<ul style="list-style-type: none"> • 60" powerway with 8 total receptacles: paint • 2-circuit powerways • 60" powerway for 2-circuit with (1) line 1 and (1) line 2 receptacles • Chicago hardwired junction boxes with 8 total receptacles: 6000 Black plastic default • Shipped ready to install 	1 Style number 2 Paint color number for powerway ▶ See <i>Surface Materials</i> , page 39.

Specification Information

• Style Number	• U.S. Price
.....

Hardwired Powerway, Two Circuit - Line 1 and Line 2

TS2P260	\$480
.....

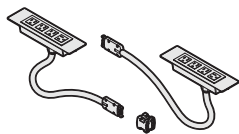

Hardwired Powerway, Chicago, Two Circuit - Line 1 and Line 2

TS2P2CHI	\$480
.....

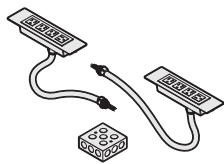

Table-to-Table Power Connector, 1-Circuit and 2-Circuit

	Standard Includes	Required to Specify
▶ Need help? Product details, page 16	<ul style="list-style-type: none"> • Modular table-to-table power connector 	Style number

Specification Information

• Style Number	• U.S. Price
.....

TS2PT2T	\$74
.....

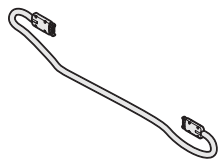

For Canadian Pricing
 Multiply U.S. Price by the
 Canadian price factor.
 ▶ See page 1 for details.

Storage

Trunk

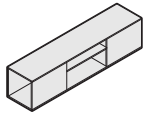

Tip: Trunks come fully assembled.

Tip: Trunk cannot be used on a Bivi Table for One.

Standard Includes	Required to Specify
-------------------	---------------------

- | | | |
|---|---|--|
| <ul style="list-style-type: none"> ▶ Need help? Product details, page 20 | <ul style="list-style-type: none"> • Trunk: Low-Pressure Laminate • Shelves: paint • Attachment hardware | <ul style="list-style-type: none"> 1 Style number 2 Low-Pressure Laminate color number for trunk 3 Paint color number for shelves ▶ See <i>Surface Materials</i>, page 39. |
|---|---|--|

Related Products

- | | |
|--|---|
| <ul style="list-style-type: none"> • Bivi Table for Two | <ul style="list-style-type: none"> ▶ Page 27 |
|--|---|

Specification Information				
Dimensions			Style	U.S.
D	W	H	Number	Price

14"	60"	16"	TS2STEH1660	\$913
-----	-----	-----	--------------------	-------

Depot

Tip: Depot storage requires assembly.

Standard Includes	Required to Specify
-------------------	---------------------

- | | | |
|---|---|---|
| <ul style="list-style-type: none"> ▶ Need help? Product details, page 20 | <ul style="list-style-type: none"> • Depot: laminate • Feet with adjustable glides • Attachment hardware | <ul style="list-style-type: none"> 1 Style number 2 Laminate color number for depot ▶ See <i>Surface Materials</i>, page 39. |
|---|---|---|

Specification Information				
Dimensions			Style	U.S.
D	W	H	Number	Price

137/8"	60"	15"	TS2ST1H1460	\$ 698
--------	-----	-----	--------------------	--------

Depot				
-------	--	--	--	--

137/8"	60"	15"	TS2ST1H1460	\$ 698
--------	-----	-----	--------------------	--------

Big Depot				
-----------	--	--	--	--

137/8"	60"	28 1/2"	TS2ST2H2860	\$1098
--------	-----	---------	--------------------	--------

Bigger Depot				
--------------	--	--	--	--

137/8"	60"	42"	TS2ST2H4260	\$1698
--------	-----	-----	--------------------	--------

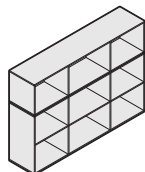
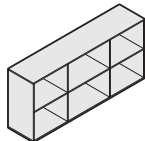
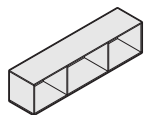

For Canadian Pricing

Multiply U.S. Price by the Canadian price factor.

▶ See page 1 for details.

Rumble Seat and Hoodie

Rumble Seat

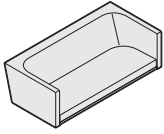

Tip: Order Rumble Seat with exposed bracket when you plan to install a Hoodie.

Standard Includes	Required to Specify
<ul style="list-style-type: none"> Fully upholstered lounge: Connect fabric Lounge shipped fully assembled Table frame attachment brackets shipped ready to assemble 	<ol style="list-style-type: none"> Style number Connect fabric color number for upholstery Paint color number for table frame attachment brackets Options, if selected (see below) <p>▶ See <i>Surface Materials</i>, page 39.</p>

Options	U.S. Price	Required to Specify
Surface Materials <ul style="list-style-type: none"> Fabric price group 1 Fire Code Seating (FCS) 	No cost +\$550	Specify fabric color number. Add suffix F to the style number.

Specification Information				
Dimensions			Style	U.S.
D	W	H	Number	Base Price
:	:	:	:	:
:	:	:	:	:

Rumble Seat

28"	58"	16"	TS3RS	\$2530
:	:	:	:	:

Rumble Seat with Exposed Bracket

28"	58"	16"	TS3RSBKT	\$2530
:	:	:	:	:



For Canadian Pricing
 Multiply U.S. Price by the Canadian price factor.
 ▶ See page 1 for details.

Hoodie

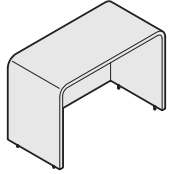

Standard Includes	Required to Specify
-------------------	---------------------

- Fully upholstered top and sides
- Mesh back panel: T615 Sultry Smoke
- Shipped ready to assemble

- 1 Style number
- 2 Connect fabric color number for top and sides
- ▶ See *Surface Materials*, page 39.

Specification Information				
• Dimensions			• Style	• U.S.
D	W	H	Number	Price

D	W	H	Style Number	U.S. Price
---	---	---	--------------	------------

Hoodie

28"	58"	38 ¹ / ₈ "	TS3RSH	\$1300
-----	-----	----------------------------------	---------------	--------

 **For Canadian Pricing**
 Multiply U.S. Price by the Canadian price factor.
 ▶ See page 1 for details.

Components and Accessories

Half-Round Table Top



Tip: Half-round table tops require assembly.

Standard Includes	Required to Specify
-------------------	---------------------

- | | | |
|---|---|--|
| <ul style="list-style-type: none"> ▶ Need help? Product details, page 24 | <ul style="list-style-type: none"> • 1/2"-thick table top: Low-Pressure Laminate • Edge band: default color to match laminate • Attachment brackets: paint | <ol style="list-style-type: none"> 1 Style number 2 Low-Pressure Laminate color number for table top 3 Paint color number for attachment brackets <p>▶ See <i>Surface Materials</i>, page 39.</p> |
|---|---|--|

Specification Information				
Dimensions			Style Number	U.S. Price
D	W	H		

27"	60"	-	TS2RW	\$458
:	:	:	:	:

Table Top

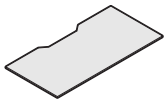

Standard Includes	Required to Specify
-------------------	---------------------

- | | | |
|---|---|--|
| <ul style="list-style-type: none"> ▶ Need help? Product details, page 24 | <ul style="list-style-type: none"> • 1/2"-thick table top: Low-Pressure Laminate • Edge band: default color to match laminate • Attachment brackets: paint | <ol style="list-style-type: none"> 1 Style number 2 Low-Pressure Laminate color number for table top 3 Paint color number for attachment brackets <p>▶ See <i>Surface Materials</i>, page 39.</p> |
|---|---|--|

Specification Information				
Dimensions			Style Number	U.S. Price
D	W	H		

28 1/2"	58 1/2"	2"	TS2RPFWS	\$638
:	:	:	:	:

Table Top with Back Pocket

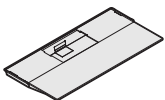

Standard Includes	Required to Specify
-------------------	---------------------

- | | | |
|---|---|--|
| <ul style="list-style-type: none"> ▶ Need help? Product details, page 24 | <ul style="list-style-type: none"> • 1/2"-thick table top: Low-Pressure Laminate • Edge band: default color to match laminate • Back pocket: paint • Two pocket covers: Low-Pressure Laminate • Attachment brackets: paint | <ol style="list-style-type: none"> 1 Style number 2 Low-Pressure Laminate color number for table top and pocket covers 3 Paint color number for attachment brackets and back pocket <p>▶ See <i>Surface Materials</i>, page 39.</p> |
|---|---|--|

Specification Information				
Dimensions			Style Number	U.S. Price
D	W	H		

28 1/2"	58 1/2"	7 1/4"	TS2RPSWS	\$838
:	:	:	:	:



For Canadian Pricing
 Multiply U.S. Price by the Canadian price factor.
 ▶ See page 1 for details.

Pocket Cover



Standard Includes		Required to Specify
<ul style="list-style-type: none"> ▶ Need help? Product details, page 24 	<ul style="list-style-type: none"> • 1/4"-thick pocket cover: Low-Pressure Laminate • Edge band: default color to match laminate 	<ul style="list-style-type: none"> 1 Style number 2 Laminate color number for pocket cover ▶ See <i>Surface Materials</i>, page 39.

Specification Information				
Dimensions			Style Number	U.S. Price
D	W	H		
12 ³ / ₄ "	19 ¹ / ₄ "	1/2"	TS2RPTC	\$90
:	:	:	:	:

Leg



Tip: This product requires assembly.

Standard Includes		Required to Specify
<ul style="list-style-type: none"> ▶ Need help? Product details, page 24 	<ul style="list-style-type: none"> • Leg: paint 	<ul style="list-style-type: none"> 1 Style number 2 Paint color number for leg ▶ See <i>Surface Materials</i>, page 39.

Specification Information				
Dimensions			Style Number	U.S. Price
D	W	H		
2"	42 ¹ / ₄ "	28 ¹ / ₂ "	TS2RPBSL	\$300
:	:	:	:	:

Top Shelf



Tip: Three shelves can fit across one Bivi table.

Standard Includes		Required to Specify
<ul style="list-style-type: none"> ▶ Need help? Product details, page 24 	<ul style="list-style-type: none"> • Shelf: paint 	<ul style="list-style-type: none"> 1 Style number 2 Paint color number for shelf ▶ See <i>Surface Materials</i>, page 39.

Specification Information				
Dimensions			Style Number	U.S. Price
D	W	H		
8 ¹ / ₂ "	19"	8"	TS2ACMS	\$198
:	:	:	:	:



For Canadian Pricing
 Multiply U.S. Price by the Canadian price factor.
 ▶ See page 1 for details.

Bottom Shelf



Tip: Bottom shelf hooks into Bivi leg.

Standard Includes	Required to Specify
<ul style="list-style-type: none"> ▶ Need help? Product details, page 24 • Bottom shelf: paint 	<ul style="list-style-type: none"> 1 Style number 2 Paint color number for shelf ▶ See <i>Surface Materials</i>, page 39.

Specification Information				
• Dimensions			• Style	• U.S.
D	W	H	Number	Price
8 ¹ / ₂ "	18 ¹ / ₂ "	17"	TS2ACTH	\$190
:	:	:	:	:

Hook



Tip: Hook attaches to Bivi leg.

Standard Includes	Required to Specify
<ul style="list-style-type: none"> ▶ Need help? Product details, page 24 • Hook: paint 	<ul style="list-style-type: none"> 1 Style number 2 Paint color number for hook ▶ See <i>Surface Materials</i>, page 39.

Specification Information				
• Dimensions			• Style	• U.S.
D	W	H	Number	Price
:	:	:	:	:

Package of Two

D	W	H	Style Number	U.S. Price
1 ³ / ₄ "	2"	1"	TS2ACMH2	\$50
:	:	:	:	:

Package of Four

D	W	H	Style Number	U.S. Price
1 ³ / ₄ "	2"	1"	TS2ACMH4	\$80
:	:	:	:	:



For Canadian Pricing
 Multiply U.S. Price by the Canadian price factor.
 ▶ See page 1 for details.

Surface Materials

► For Surface Materials matrices for all product lines, see page 241

Paint

Steelcase Surfaces

Applies to:

- Cable trough
- Bivi legs
- Trunk shelves
- Turnstone table legs
- Back pocket
- Power kit
- Attachment bracket
- Top shelf
- Bottom shelf
- Hook

4799 Platinum Metallic

7241 Arctic White

7246 Midnight Metallic

Applies to:

- Table frame attachment brackets

4799 Platinum Metallic

7241 Arctic White

7246 Midnight Metallic

Laminate

Steelcase Surfaces

Low-Pressure

Laminate

Applies to:

- Bivi table tops
- Depot
- Trunk
- Turnstone table top
- Pocket covers

25L5 Virginia Walnut LPL

25L6 Blackwood LPL

25L8 Clear Walnut LPL

25L9 Warm Oak LPL

Upholstery

Steelcase Surfaces

Applies to:

- Rumble Seat
- 5S15 Coconut
- 5S16 Turmeric
- 5S17 Tangerine
- 5S18 Scarlet
- 5S19 Concord
- 5S20 Maya Blue
- 5S21 Blue Jay
- 5S23 Wasabi
- 5S25 Graphite
- 5S26 Licorice
- 5S28 Root Beer
- 5S98 Canary

Applies to:

- Hoodie top and sides
- 5S25 Graphite
- 5S26 Licorice

Mesh

Applies to:

- Hoodie back

T615 Sultry Smoke



Tour Workspace

Tip: Established finishes are available for delivery in 15 business days.

E = Established

Statement of Line **42**

Product Details

Counter and Countertop Facts	43
Electrical Facts	44
Bench Component Facts	52
Worksurface and Shelf Facts	56
Worksurface Supports Facts	58
Screen and Screen Connector Facts	60
Freestanding Screen Stability Rules	63
HV Cabinet Facts	64
Bookcase Facts	65
My File Facts	66
Pile File Facts	67

Specifying

Counters and Countertops	68
Electrical Components	70
Worksurface-Height Power and Communication Access	78
Bench Components	83
SOTO Tour Rails	84
Worksurfaces	85
Worksurface Supports	90
Shelves	93
Modesty Panels	94
Screens and Screen Connectors	95
HV Cabinets	97
Bookcases	99
My File	100
Pile File	102
Magnetic Markerboards and Tackboards	103
Task Lights	104
SOTO	105

Surface Materials **106**

Statement of Line

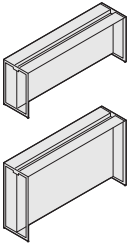

Counters
▶ Page 68

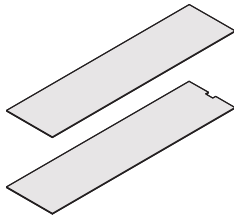

Countertops
▶ Page 69

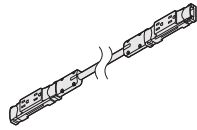

Electrical Components
▶ Pages 70–77

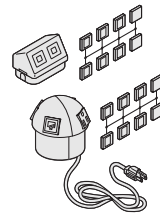

Power and Data Accessories
▶ Pages 78–82

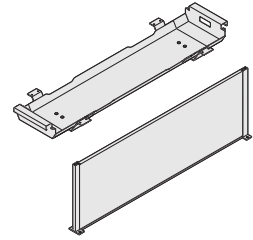

Bench Trough and Screen
▶ Page 83

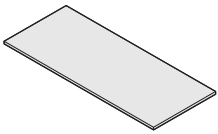

Straight Worksurfaces
▶ Page 85

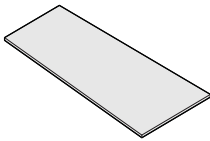

Tapered Worksurfaces
▶ Page 86

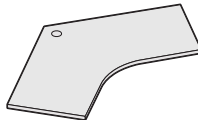

120° Worksurfaces
▶ Page 87



Round Worksurfaces
▶ Page 88

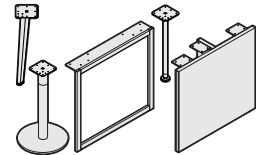

Worksurface Supports
▶ Pages 90–92

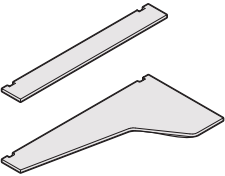

Shelves
▶ Page 93

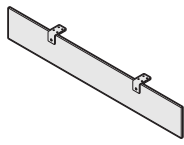

Modesty Panels
▶ Page 94

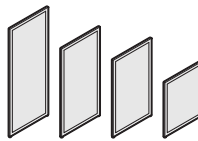

Screens and Screen Connectors
▶ Page 95

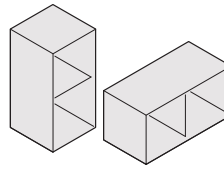

HV Cabinet
▶ Page 97

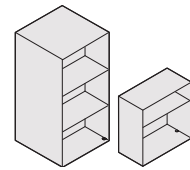

Bookcases
▶ Page 99

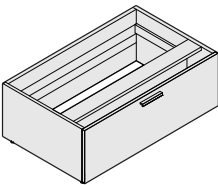

My File
▶ Page 100

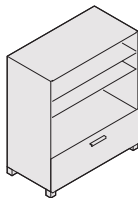

Pile File
▶ Page 102

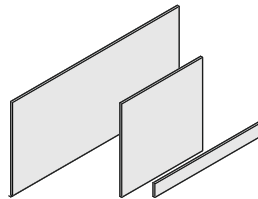

Magnetic Markerboards and Tackboards
▶ Page 103



Details Worktools
▶ Page 209

Counter and Countertop Facts

Counters are constructed with a painted steel horizontal component and clear anodized aluminum end supports. Counters are 30"H or 42"H x 18"D x 72"W. A laminate infill on the counter centerline provides stability and can be optioned in painted steel. Counters ship knocked down in five pieces.

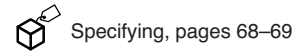

Specifying, pages 68–69

Directional laminate

runs horizontal on the counter center infill, and runs vertical on the optional frame support infills.

Laminate countertops provide a finished appearance to the top of the counter. Countertops are not necessary where a HV cabinet is used. Countertops are available in four sizes, 18"D x 18"W, 36"W, 54"W, or 72"W. Countertops are also available with a notch that facilitates access to data components.

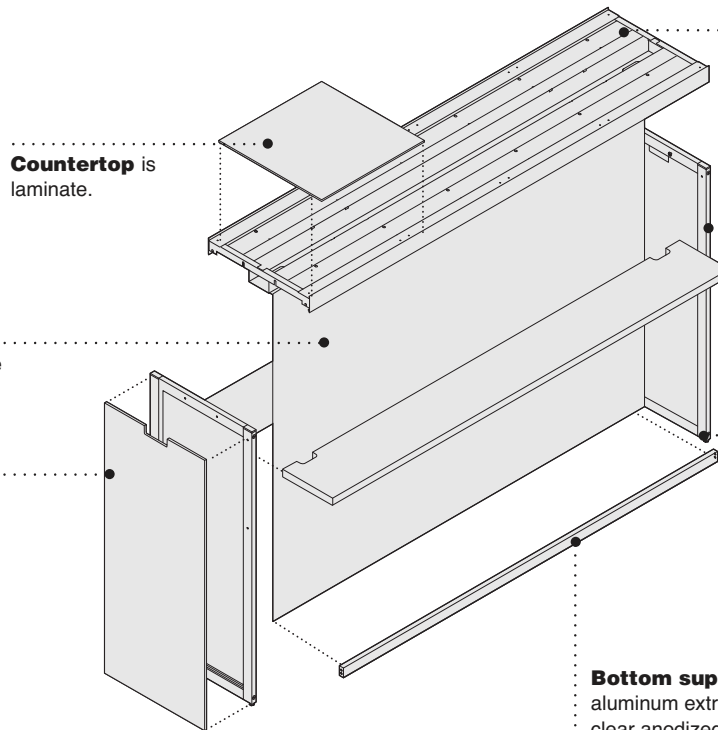

Countertop is laminate.

Countertop tray is painted steel. Power runs down the center of the tray. 3" front accepts magnets while the recess underneath accepts lights. HV cabinets, bookcases, and countertops fit in the counter tray.

Center infill is laminate or steel.

End support is aluminum extrusion in clear anodized finish only.

Laminate infills are available as an option for frame support.

Leveling glides adjust 1/2" to accommodate uneven floors.

Bottom support bar is aluminum extrusion in clear anodized finish only.

Counters attach to each other when oriented in a straight line and are the same height. Counter-to-counter attachment hardware is included.

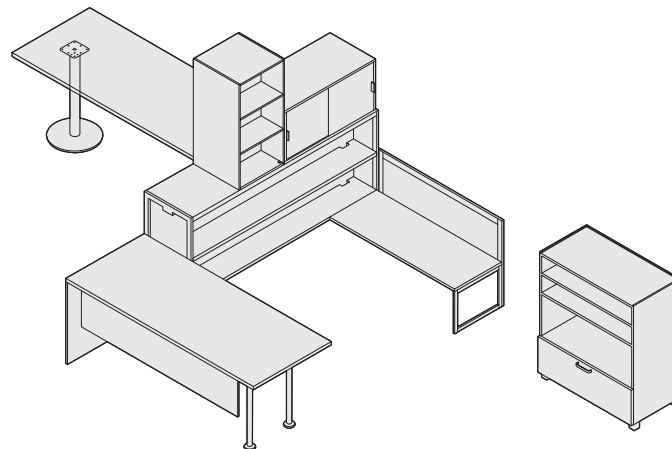

Recess underneath the counter can accommodate an under-shelf task light.

Electrical Facts

Powerways

Factory-installed powerway is a one-circuit system. Multiple circuits can be utilized depending on which building circuit is accessed.

A one-, two-, or four-circuit powerway is available for field installation.

Optional powerway has four duplex receptacles (two on each end) that are accessible from underneath top of counter.

All powerways and base power-ins are PVC-free.

Base power-in can connect to either end of any powerway, including a counter in the middle of a run of connected counters.

 Specifying, page 70

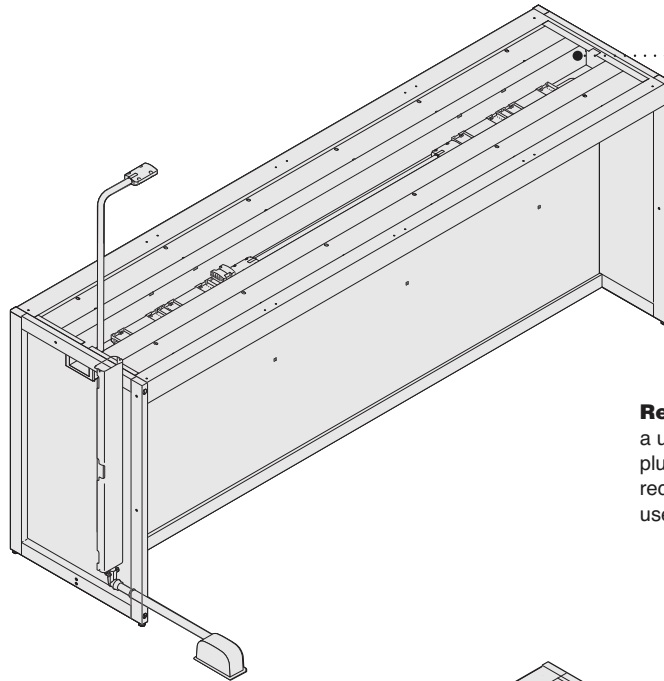

Data cords can be managed in the top of the counter which holds a quantity of 42 CAT5e or 32 CAT6 cables.

Receptacle base power-in allows a user to power a counter with a simple plug to a 20-amp building receptacle. A receptacle base power-in can only be used with a one-circuit powerway.

A hard-wired base power-in provides traditional access to the building power source. This can be used for either one-, two-, or four-circuit powerways.

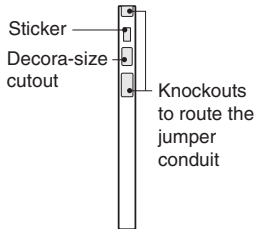

There are three knockouts in the 30" and 42" vertical wire managers, style numbers TSTECC30 and TSTEC42. The first and third are available to route Tour power jumpers when used and the second is standard Decora-size to fit data ports, approximately 1 $\frac{3}{4}$ "W x 2 $\frac{5}{8}$ "H.

A quantity of 24 CAT5e or 18 CAT6 cables can be managed down the vertical wire manager.

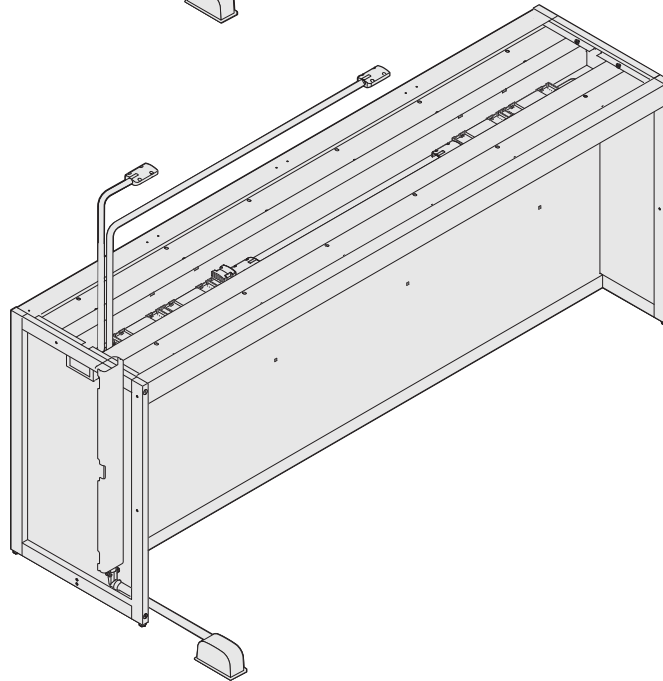

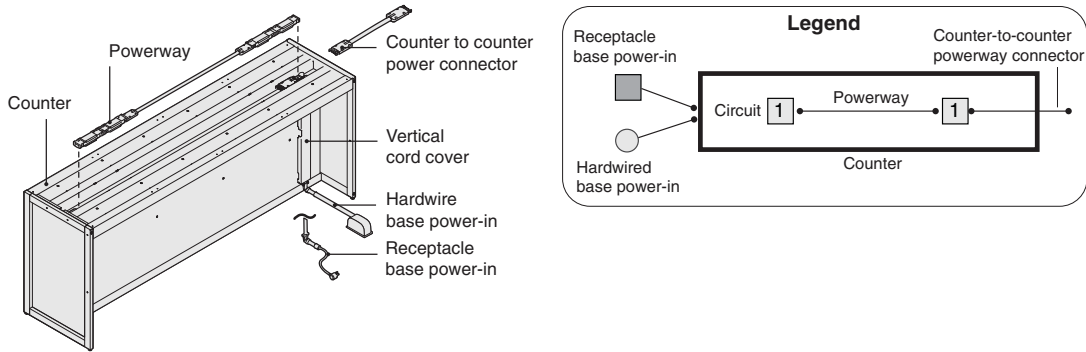

One-circuit Solution



Notes:

- Two different base power-in options:
 - One-circuit receptacle base power-in (TSTEPBR130 or TSTEPBR142)
 - Two-circuit hardwired base power-in (TSTEPBT2)
- One-circuit powerway available as factory-installed or field-installed (TSTEP172).
- Counter-to-counter powerway connector (TSTEP2C) is a two-circuit connector
- Base power-in can be installed on any counter - at middle or end-of-run
- Maximum run is three counters (six users)

Two-circuit Solution



Notes:

- One base power-in option
 - Two-circuit hardwired base power-in (TSTEPBT2)
- Two-circuit powerway (TSTEP272) is field-installed only
- Counter-to-counter powerway connector (TSTEP2C) is a two-circuit connector
- Base power-in can be installed on any counter - at middle or end-of-run
- Maximum run is six counters (twelve users)

Four-circuit Solution

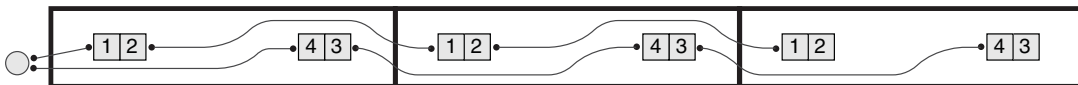

Notes:

- One base power-in option
 - Four-circuit hardwired base power-in (TSTEPBT4)
- Four-circuit powerway (TSTEP472) is field-installed only, and includes a Line 1 and Line 2 receptacle, and a Line 3 and Line 4 receptacle.
- Counter-to-counter powerway connector (TSTEP2C4) is a four-circuit connector.
- Base power-in can be installed on any counter - at middle or end-of-run
- Maximum run is thirteen counters (twenty-six users)

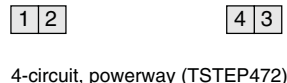
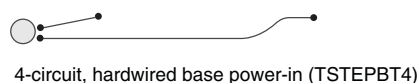

Electrical Facts

Counter-to-Counter Connectors

 Specifying, page 73

Counters must be connected with enclosed attachment brackets.

Counters must be connected to counters of the same height, either 30"H or 42"H.

Counter-to-counter connectors are available to route power (1- or 2-circuit or 4-circuit) from one counter to another by using a modular connection.

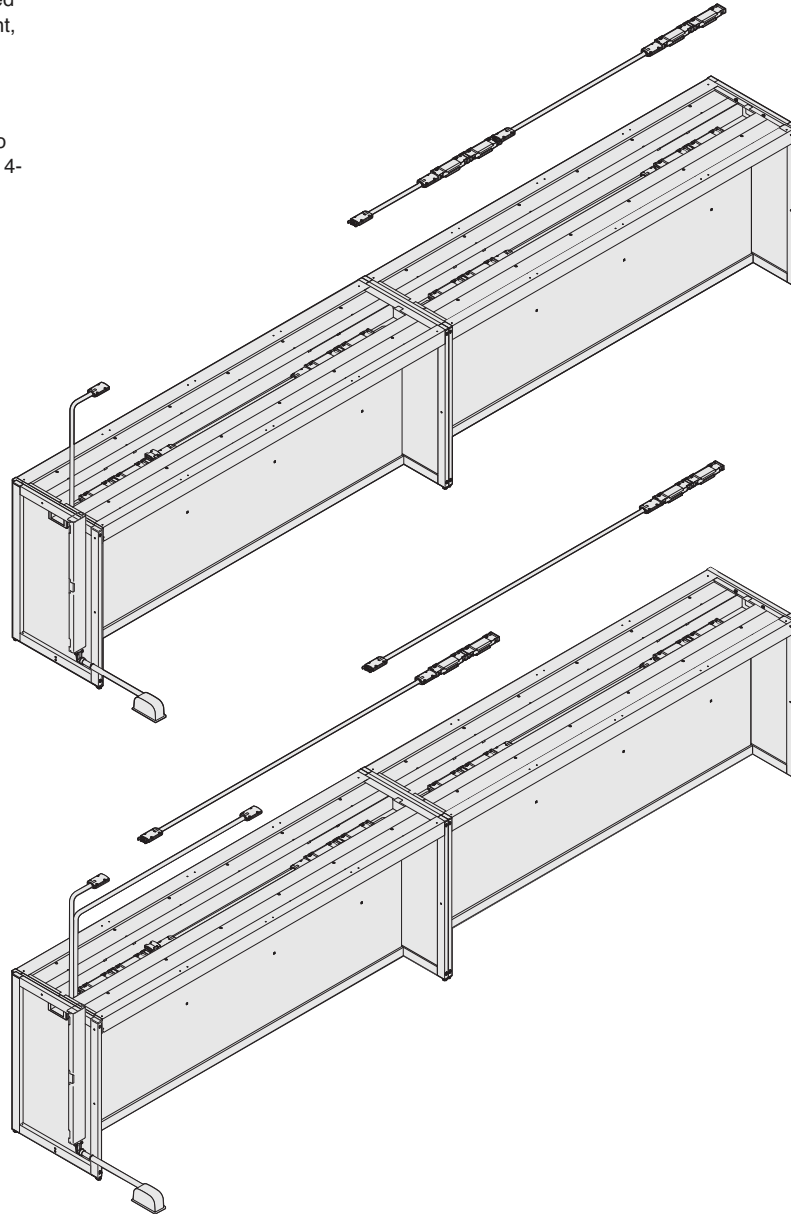

Data can be routed from counter-to-counter, and vertically through the vertical cord manager.

Receptacle base power-in allows a user to power a counter with a simple plug to a 20-amp building receptacle, and extend 24" outside the counter. A receptacle base power-in can only be used with a one-circuit powerway.

A hardwired base power-in provides traditional access to the building power source. This can be used for either one-, two-, or four-circuit powerways.

San Francisco base power-ins have 72" outside of counter.

Electrical Facts

Counter-to-Counter Power Jumpers

Power jumpers move power from one counter to the next counter when they are separated by a worksurface(s).

Power jumpers are used as an alternative solution to a separate base power-in per counter when raised flooring to access power is not available, or not desirable.

Power Jumper Rules

The following applies to all applications of power jumping:

1. Counters and worksurfaces must be mechanically attached – the worksurfaces must be attached to either a counter, a shelf, or counter end frame. If multiple worksurfaces are used between counters they must also be connected to each other with tie plates.
2. Jumpers must be secured to the worksurface - this is accomplished in two ways:
 - a. Connect jumper every 12" with provided fasteners.
 - b. Encasing jumper in provided horizontal wire manager, which is required, if jumper is routed within 18" of an exposed user edge.
3. In-line jumpers: 2' minimum, and 4' maximum between counters. Side-by-side and benching jumpers: 4' minimum, and 10' maximum between counters.



Specifying, pages 74-77

There are three types of power "jumpers" depending on your configuration:

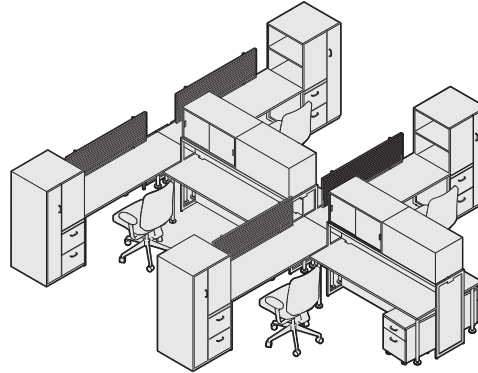

In-line jumper—two counters in-line with a worksurface(s) between them, (2' min - 4' max between counters).

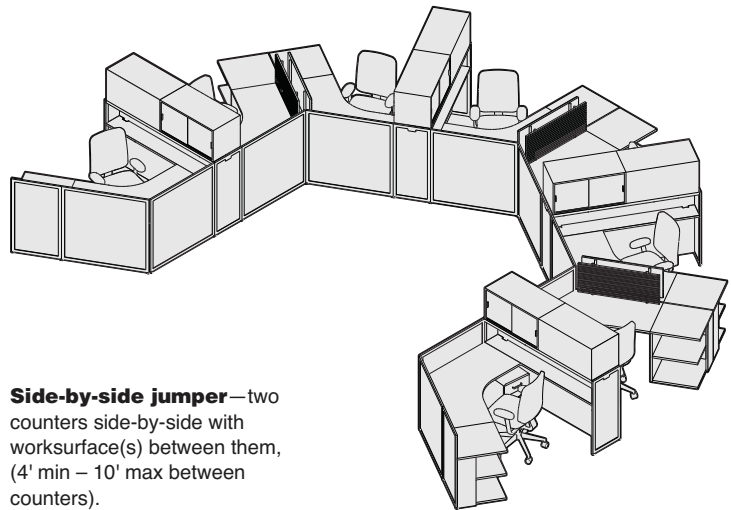

Side-by-side jumper—two counters side-by-side with worksurface(s) between them, (4' min – 10' max between counters).

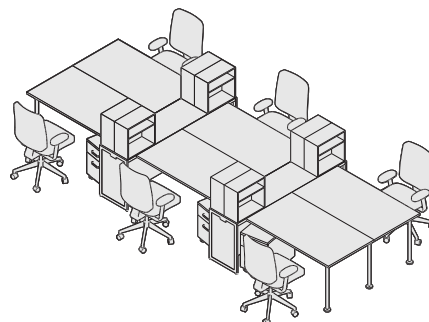

Benching jumper—two counters with benching worksurfaces between them, (4' min – 10' max between counters)

Electrical Facts

Specifying Power Jumpers

The style number of the jumper is determined by four pieces of information:

1. Type of jumper: in-line, side-by-side, or benching.
2. Which power system is selected 1- and 2 -, or 4-circuit.
3. If worksurfaces are at the same height or different height than the counter (change of height).

Determine the answer to the above three questions and select appropriate "routing inches" provided for you in the matrix.

4. Length of worksurface(s) - measure the length of the worksurface or worksurfaces being used between the two counters. This includes shelf inches that are outside the footprint of the counter. Example: A 21" shelf would add 12" to the worksurface length.

The jumper style number length will equal number of routing inches plus the length of your worksurface(s).

Style number required = number of routing inches + number worksurface inches

Note: If style number length is not available round up to the next length of jumper.

Example 1:

1. In-line jumper
2. 2-circuit power
3. worksurface/counter same height
4. one 24" wide worksurface
 Style number = routing inches (see matrix) + worksurfaces inches
 $45" + 24" = 69"$
 Jumper style number = TSTEP2C069

Example 2:

1. Side-by-side jumper
2. 4-circuit power
3. worksurface/counter different heights
4. two 36" wide worksurfaces
 Style number = routing inches (see matrix) + worksurfaces inches
 $108" + 72" = 180"$
 Jumper style number = TSTEP4C180

Example 3:

1. Benching jumper
2. 4-circuit power
3. worksurface/counter different heights
4. one 72" wide worksurface
 Style number = routing inches (see matrix) + worksurfaces inches
 $135" + 72" = 207"$
 Jumper style number = TSTEP4C207

Routing Inches Matrix

	In-Line Jumper	Side-by-Side Jumper	Benching Jumper
1- and 2-circuit power Same height (worksurface and counter at the same height)	45"	57"	83"
1- and 2-circuit power One change-of-height (worksurface same height as one counter, different height than second counter)	56"	69"	95"
1- and 2-circuit power Two change-of-height (worksurface at different height than both counters)	67"	81"	107"
4-circuit power Same height (worksurface and counter at the same height)	71"	84"	110"
4-circuit power worksurface One change-of-height (worksurface same height as one counter, different height than second counter)	83"	96"	123"
4-circuit power Different Two change-of-height (worksurface at different height than both counters)	95"	108"	135"

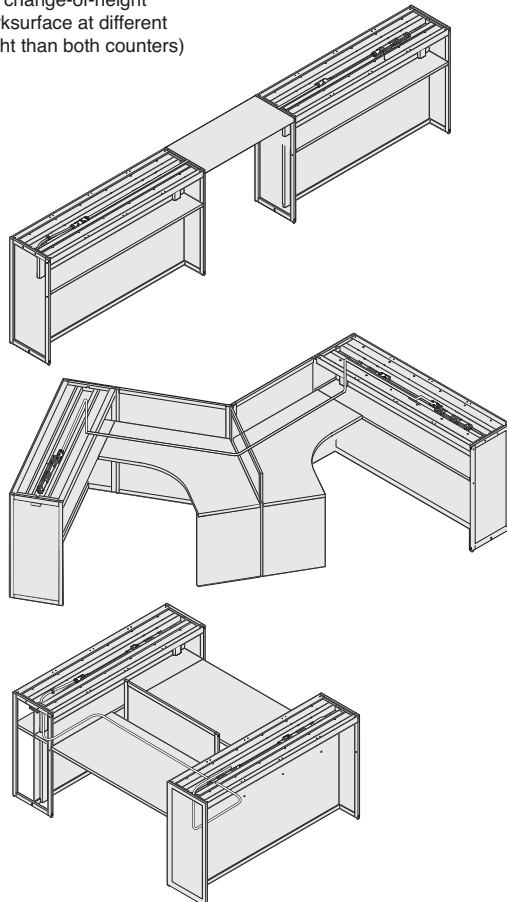

Electrical Facts

In-Line Jumpers

Multiple surfaces can be used as long as they do not exceed the 4' width max between counters.

Open counter end frames (no end fills) required when power is passing from counter to counter.

If end fills are specified field-installed grommet cutouts will be required to use power jumpers.

Counter end frames on the outside counters can have end fills.

C-clamps and horizontal cord managers (TSTECM) are included with power jumpers for installation.

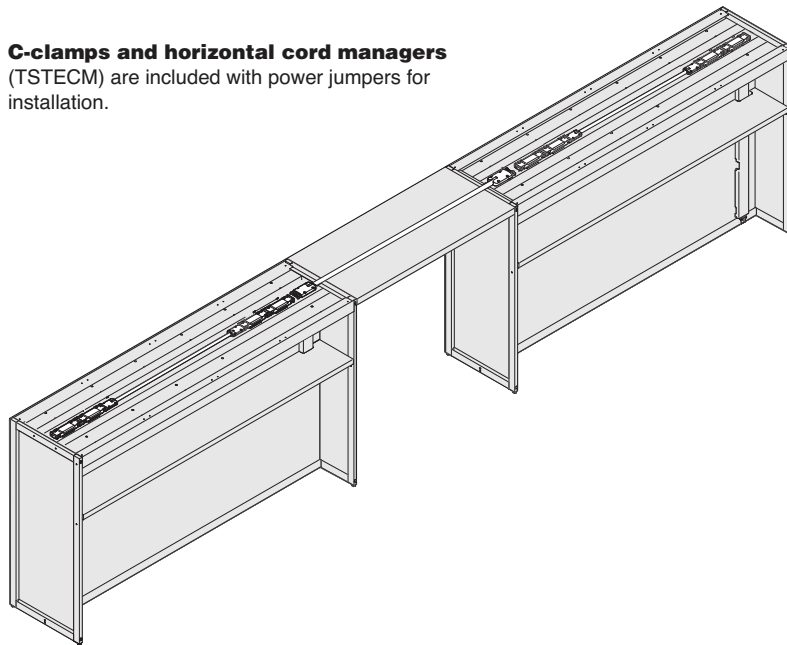

If counters at the same height of the work surface the power is routed through the counter end cap, underneath the work surface, and through the adjacent counter end cap.

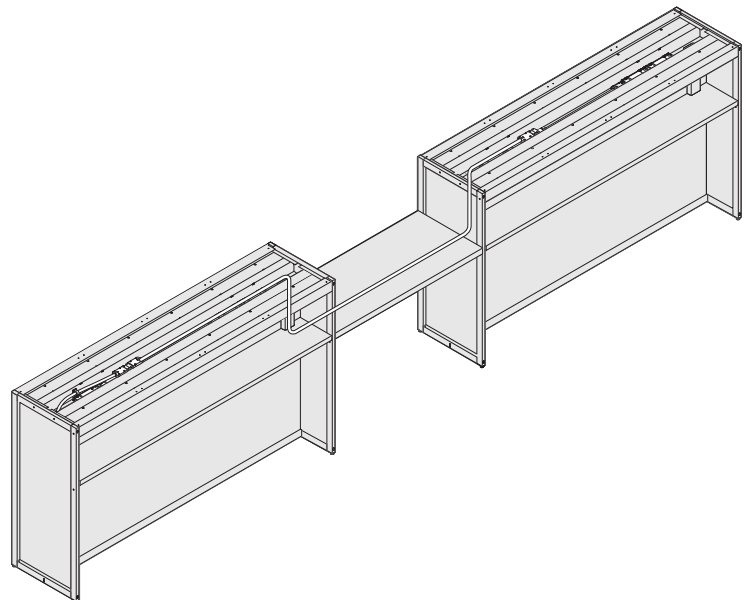

If counters at different height than the work surface the power is routed down the vertical wire manager, underneath the work surface, and back up to the next counter's vertical wire manager.



Specifying, pages 74-77

Standard Rules

1. Counters and worksurfaces must be connected
2. Jumpers must be secured
3. In-line jumpers: 2' minimum, and 4' maximum between counters

Side-by-side and benching jumpers: 4' minimum, and 10' maximum between counters.

Electrical Facts

Side-by-Side Jumpers

Power is routed 4" from the back edge of the worksurface to position jumper away from the user.

Multiple surfaces can be used as long as they do not exceed the 10' width max between counters.

If Screens are used between worksurfaces field installed grommets will be required to use power jumpers.

 Specifying, pages 74-77

Standard Rules

1. Counters and worksurfaces must be connected
2. Jumpers must be secured
3. In-line jumpers: 2' minimum, and 4' maximum between counters

Side-by-side and benching jumpers: 4' minimum, and 10' maximum between counter.

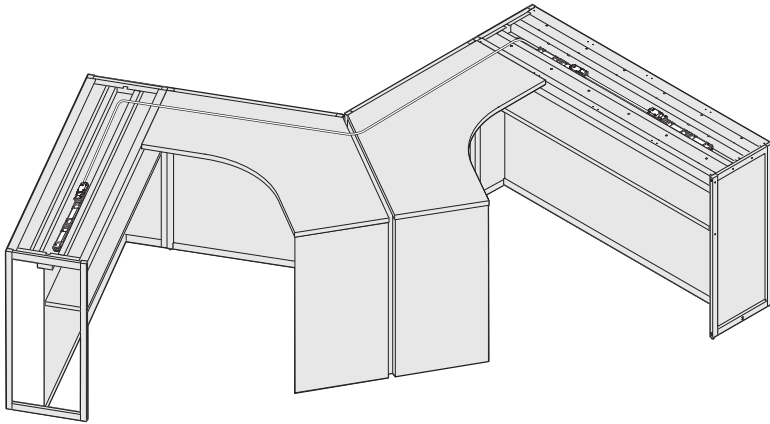

Counters at the same height of the worksurface, power is routed out the vertical wire manager, underneath the worksurface, and back in the next counters' vertical wire manager.

Counters at different height than the worksurface, power is routed out the vertical wire manager, underneath the worksurface, and back in the next counters' vertical wire manager.

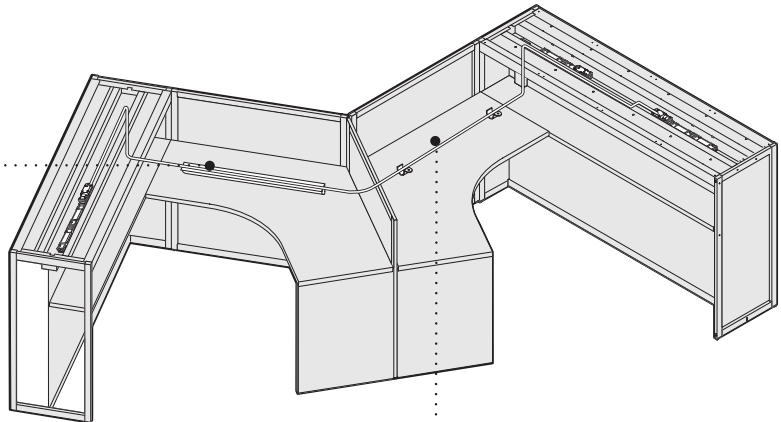

C-clamps and horizontal cord managers (TSTECM) are included with power jumpers for installation.

Electrical Facts

Benching Jumpers

Power is routed 4" from the back edge of the work-surface to position Jumper away from the user.

Benching Jumpers are called out separately because they require additional Jumper length in order to position the Jumper a minimum 18" away from the user side.

Multiple surfaces can be used as long as they do not exceed the 10' width max between counters.



Specifying, pages 74-77

Standard Rules

1. Counters and worksurfaces must be connected
2. Jumpers must be secured
3. In-Line Jumpers: 2' minimum, and 4' maximum between counters

Side-by-Side and Benching Jumpers: 4' minimum, and 10' maximum between counter.

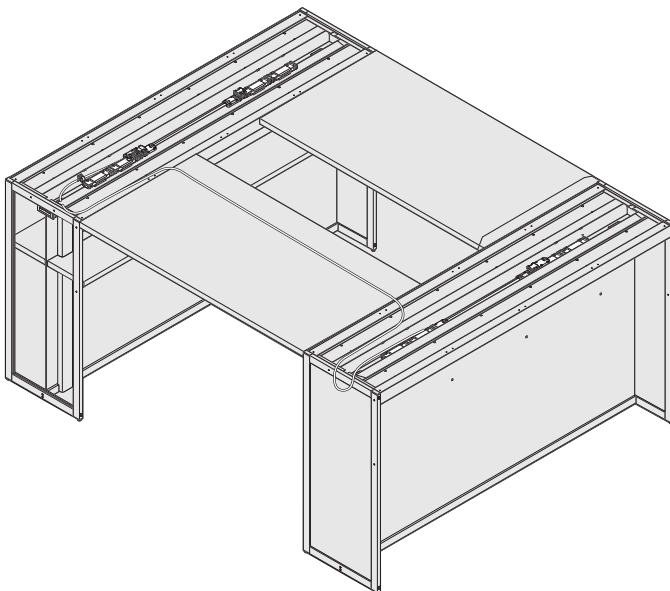

Counters at the same height of the worksurface, power is routed down the vertical wire manager, underneath the worksurface, and back up to the next counters' vertical wire manager.

C-clamps and horizontal cord managers (TSTECM) are included with power jumpers for installation.

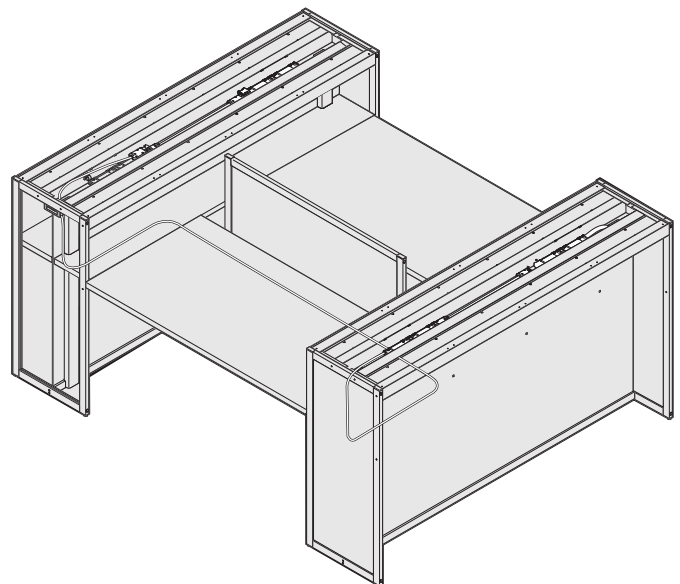

Counters at different height than the worksurface, power is routed down the vertical wire manager, underneath the worksurface, and back up to the next counters' vertical wire manager.

Bench Component Facts

 Specifying, page 83

Tour benching products consist of a bench trough and screen. The trough has functional dimensions of 4³/₈"D x 10¹/₂"W x 60-72"L providing ample space to store and manage cables. The open design allows for quick connect/disconnect access.

Bench screen is painted steel and attaches to the center of the bench trough. It accepts magnetic accessories such as the magnetic tackboards and markerboards.

The worksurfaces overhang the bench trough for clamp on accessories. There are also four cut-outs in the trough to provide additional space for clamp on accessories.

Bench trough is painted steel and telescopes from 60" to 72" to accommodate different worksurface lengths. When used with two 30" deep worksurfaces the overall depth of worksurface and trough will be 70" to match the counter shelf length. When used with two 24" deep worksurface the overall depth of the worksurface and trough will be inset 6" on both sides of the shelf.

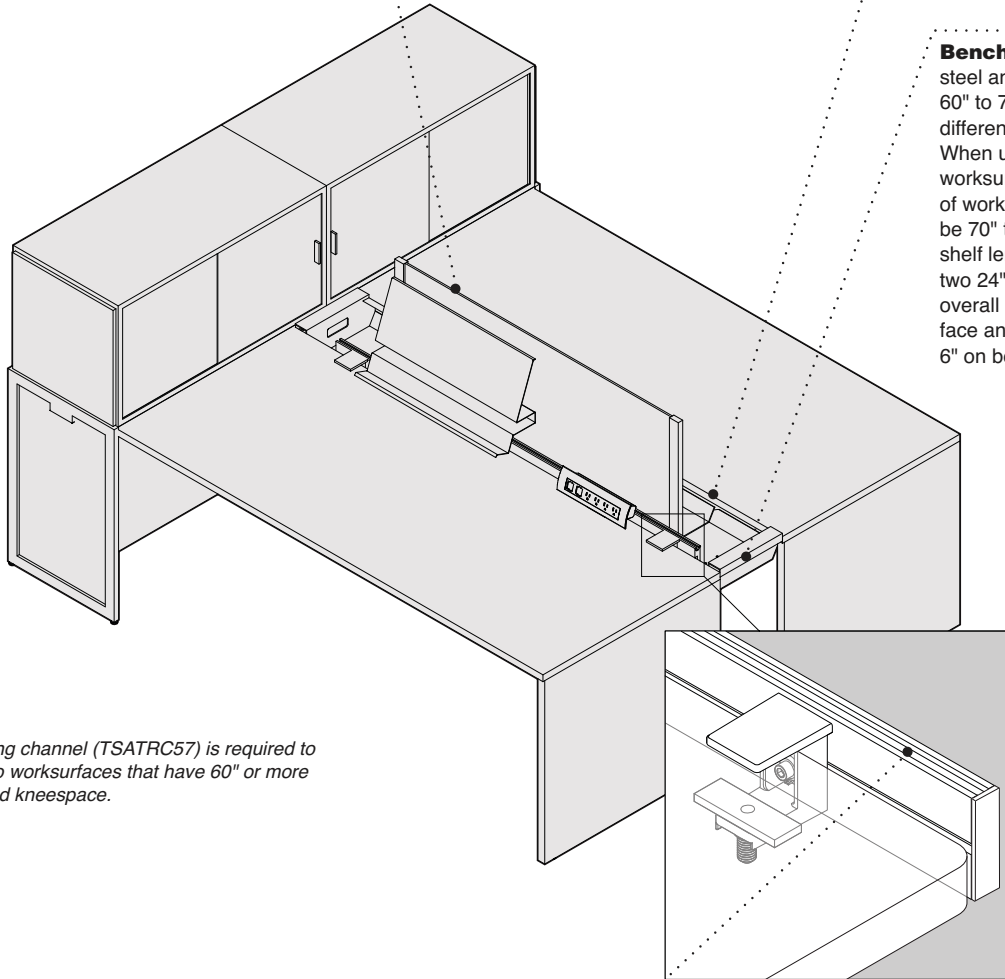

Tip: Reinforcing channel (TSATRC57) is required to add support to worksurfaces that have 60" or more of unsupported kneespace.

Tour SOTO rail has attachment hole locations that line up with bench trough cut-outs.

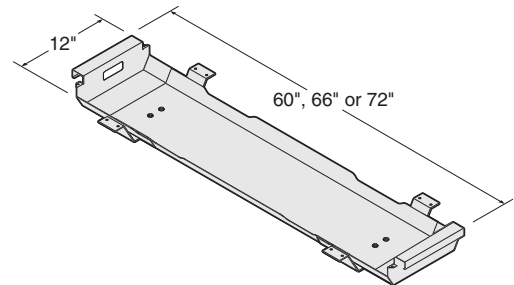

Electrical Facts

Tour Wire Management and Power and Data Accessories

Power and data accessories can mount at any location on worksurfaces and shelves.

Worksurface mounted accessories simply clamp onto worksurfaces.

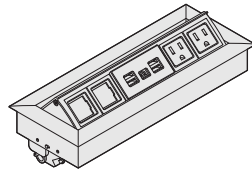

Grommets for retractable power (TSTERPDWR) are field installed.
▶ Pages 81



Vertical cord cover (TSTECC30, TSTECC42) comes in two height 30" and 42", and is used to conceal and route cables vertically. Data ports can be installed in the vertical cord cover and sits proud. Vertical cord cover grommet (TSTEGC) for data/power cable routing.

Note: Communication voice/data jacks are customer provided: The manufacturer of the communication port in the vertical cord cover picture is HellermannTyton style number's: FPFURN3 – FW (furniture white), FPFURN3 – BLK (black).

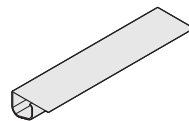

Horizontal cord cover (TSTECHM)
▶ Page 79

Used to conceal and route cables underneath the worksurface.

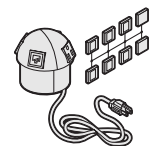

Grommets for power sphere (TSTERPDWD) are field installed for all worksurfaces except 120° worksurfaces.
▶ Page 79

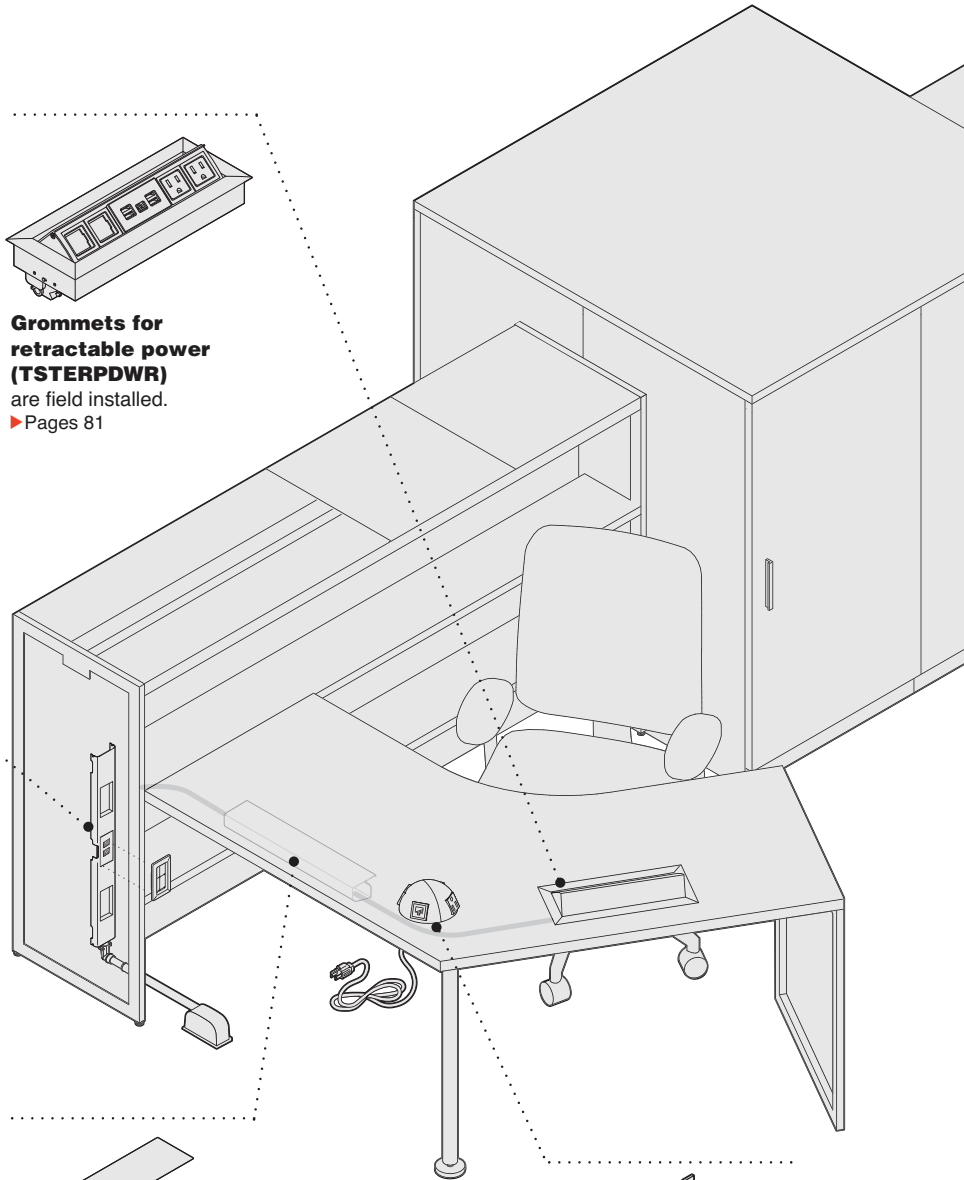

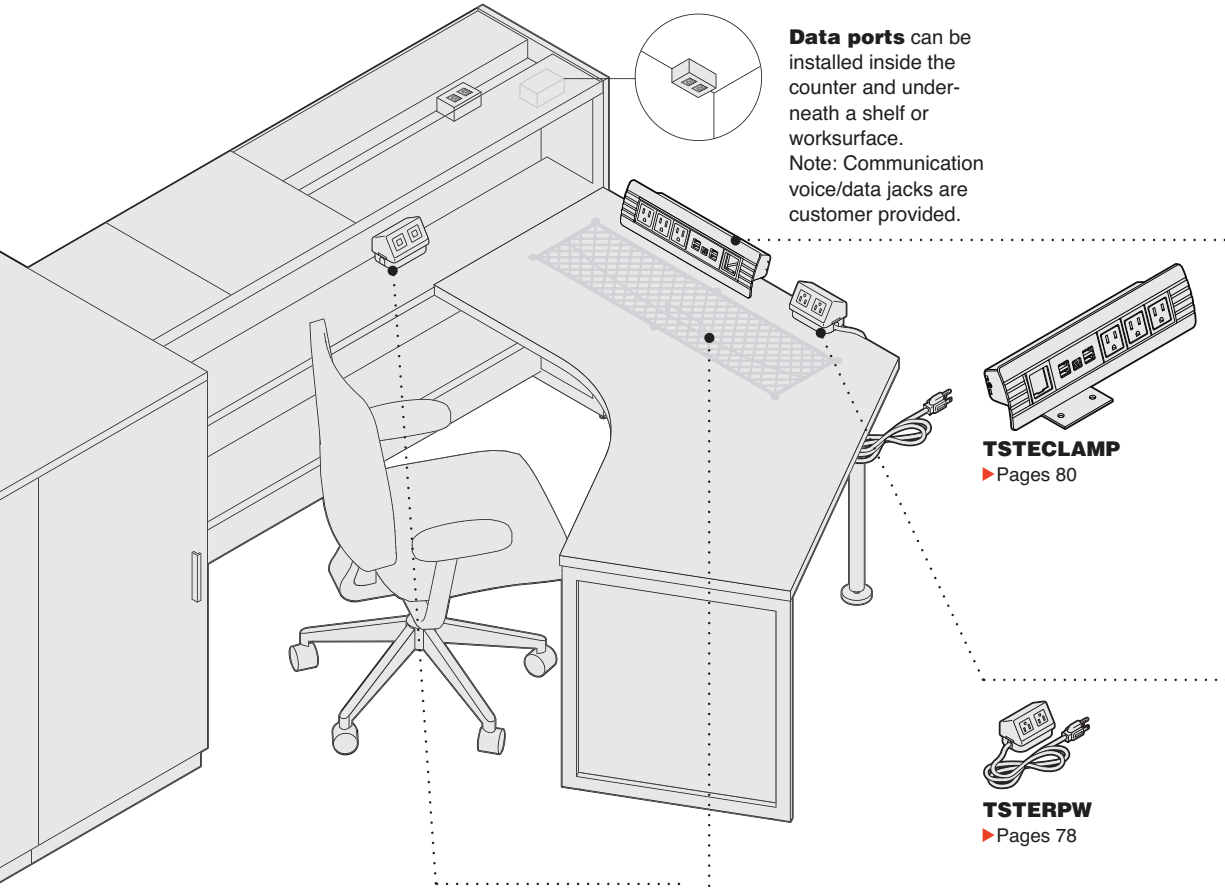

Data ports can be installed inside the counter and underneath a shelf or worksurface.
 Note: Communication voice/data jacks are customer provided.

Tour clamp-on accessories work on surfaces 3/4" to 1 1/4" thick. They do not work on surfaces over 1 1/4" thick.

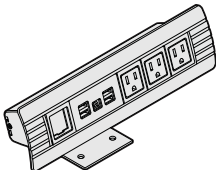

TSTECLAMP
 ▶ Pages 80



TSTERPW
 ▶ Pages 78

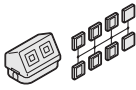

TSTERDW
 ▶ Pages 78

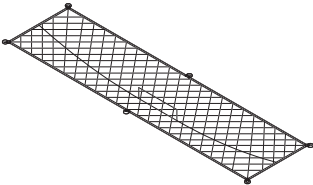

Elastic mesh cable bag (TSTECB) keeps cords secure while providing easy access points.
 ▶ Pages 80

Worksurface and Shelf Facts

Worksurface has a wood core with plastic edge band. Low-Pressure Laminates (LPL) and High-Pressure Laminates (HPL) are available. Plastic edge band color is selectable. Because the actual thickness of LPL, HPL, and wood veneer worksurfaces are slightly different, it is recommended that only worksurfaces of the same type are specified in a single application. In addition, there may be a sheen or texture difference when using LPL or HPL in adjacent applications.

Shelves are available in rectangular or extended corner shapes. Shelves can be mounted to one or both sides of the counters at coffee table height (on 30"H counter) or at worksurface height and coffee table height (on 42"H counter). Counters do not require counter-balancing if shelves are on one side only.

Tour is available in a variety of worksurface and shelf shapes. Directional laminate grain direction is shown.

Shelves can be placed at any height on the counter. *Note: Holes are pre-drilled at specific heights. When planning to have a worksurface attached, be sure to place the shelf at a height that can be accommodated by a worksurface support. Height-adjustable post legs and the adjustable round table bases allow for some flexibility.

Palletizing streamlines unloading and staging of worksurfaces. Identical worksurfaces ordered on the same line item are packed on pallets containing 10–20 worksurfaces. Remaining worksurfaces are packed individually in cartons. If palletizing is not desired, order in quantities of nine or less per line item. For maximum unload efficiency, utilize pallet handling equipment at job site whenever possible.

21"D and 33"D shelves extend 12" and 24" respectively outside the footprint of a counter. When a worksurface is attached to a shelf in a return configuration, the workstation can be wrapped in screens as a 6" module is maintained. *Tip: These shelves require additional support such as a post leg or an end panel support.*

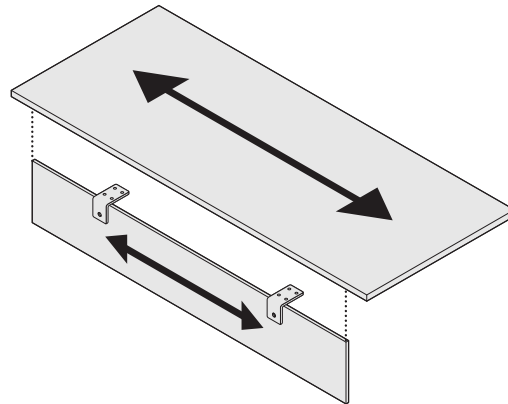

 Specifying, page 85

User's edge profile is plastic with a 3 mm radius. Back edge and edge that joins to adjacent worksurface is 1 mm.

All shelves have a cutout for vertical cord manager.

21"D and 33"D rectangular shelves and corner shelf require additional support of a post leg or end support.

Note: 21"D shelf provides 12" of worksurface space beyond the counter, the 33"D shelf provides 24".

Tip: Reinforcing channel (TSATRC57) is required to add support to worksurfaces that have 60" or more of unsupported kneespace.

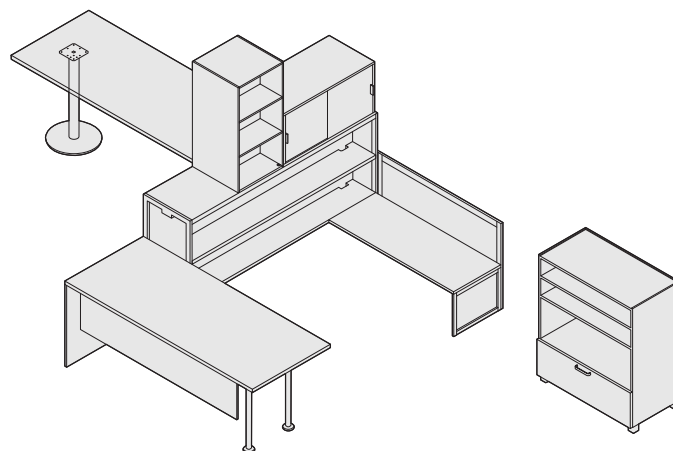

Worksurface Supports Facts

Supports are ordered separately and installed in the field.

Mounting hardware is included with each type of support.

Recommended worksurface supports for some specific applications are shown below.

Frame worksurface support cannot support both ends of a freestanding worksurface. Frame worksurface support has leveling glides. Use a laminate worksurface support, two post legs, Currency square legs, or a round table base on one end.

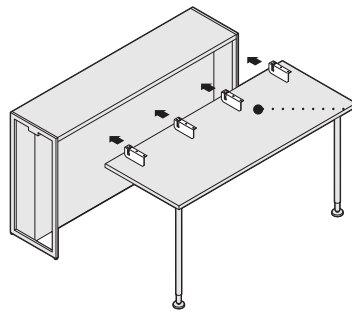

If worksurface is attached directly to the top of counter in a parallel application, two sets of counter-to-worksurface tie plates are required.

Base

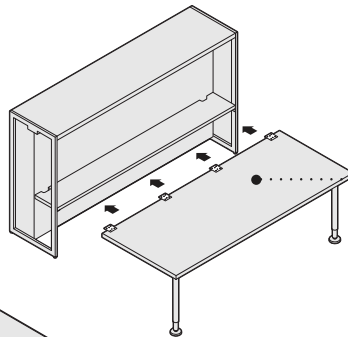

If worksurface is attached to a shelf in a parallel application, two sets of shelf-to-worksurface tie plates are required.

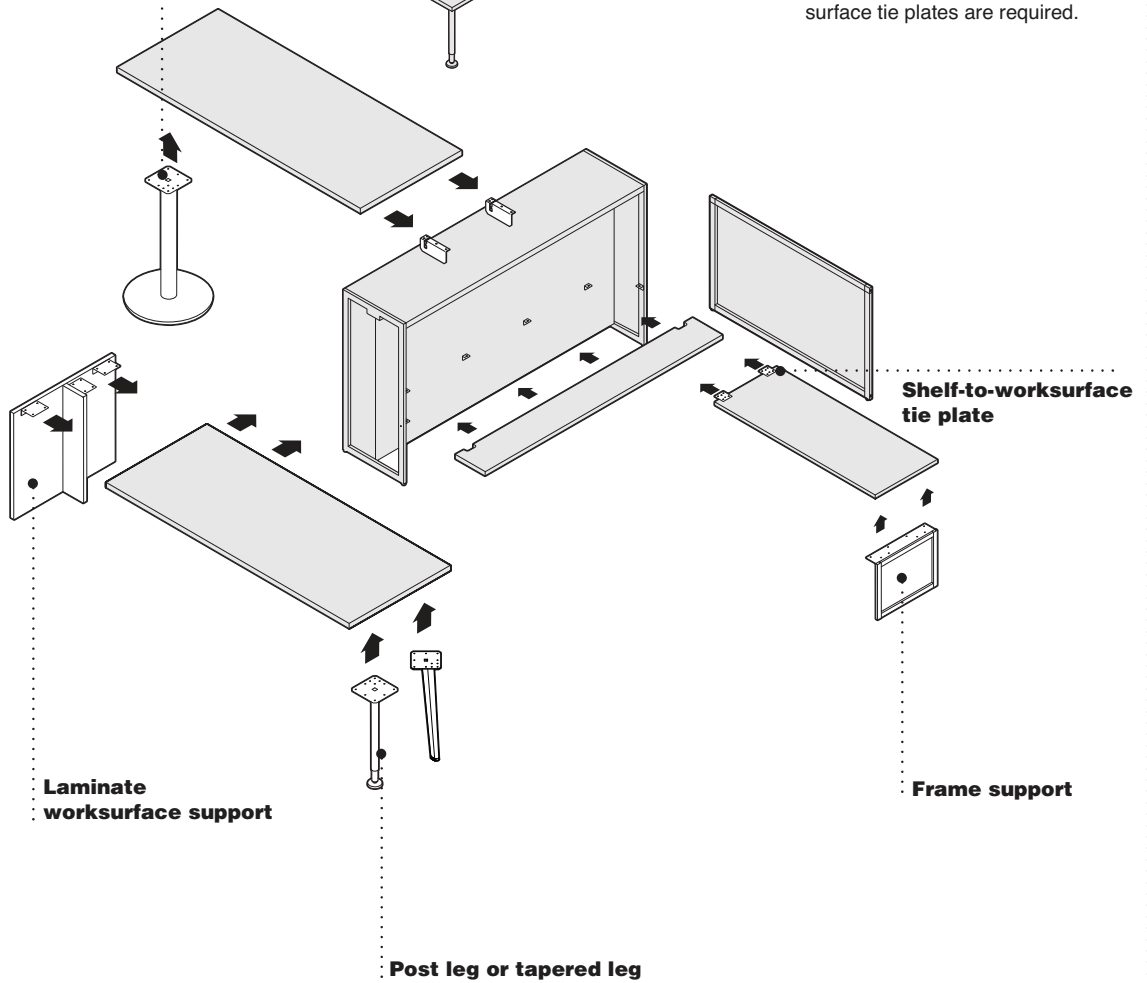



Specifying, pages 90–92

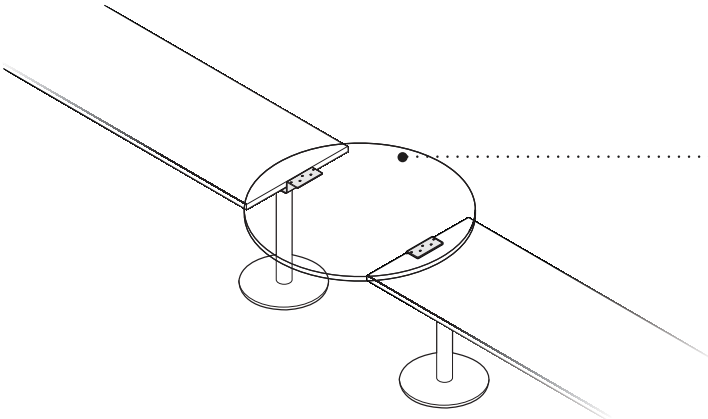

Floating round work-surface support is approved to work with 30" and 36" diameter work-surfaces. Round work-surfaces can overlap a tapered or straight work-surface by 2" minimum to 8" maximum.

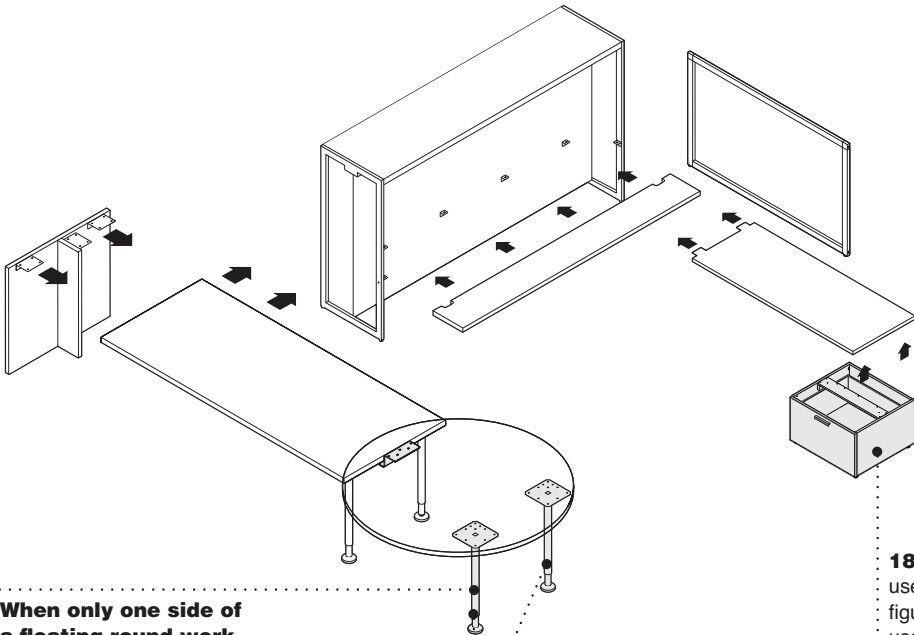

When only one side of a floating round work-surface is overlapping, additional support is required, such as two adjustable post legs or a Tour round table base.

Adjustable-height post legs are recommended to offset the 1" taller worksurface height.

18"W my file cannot be used in a freestanding configuration. My file must be used at the opposite end of a worksurface attached to a counter shelf.

Screen and Screen Connector Facts

 Specifying, pages 95–96

Screens are constructed with a clear anodized aluminum frame with a laminate infill.

Screens can be connected inline, 120° screen application with two or three screens, or in L-, or T-configurations to other screens or to counter end supports. Connection hardware is ordered separately.

Screens are non-load bearing.

Screen connection hardware require a T27 TOR X driver bit.

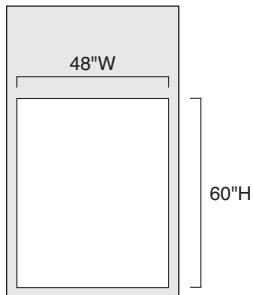

Tour screens are not available in widths larger than 48". The laminate infill used in the construction of screens are only available in 4' x 8' sheets. Directional laminates will run vertically on all sizes of Tour screens.

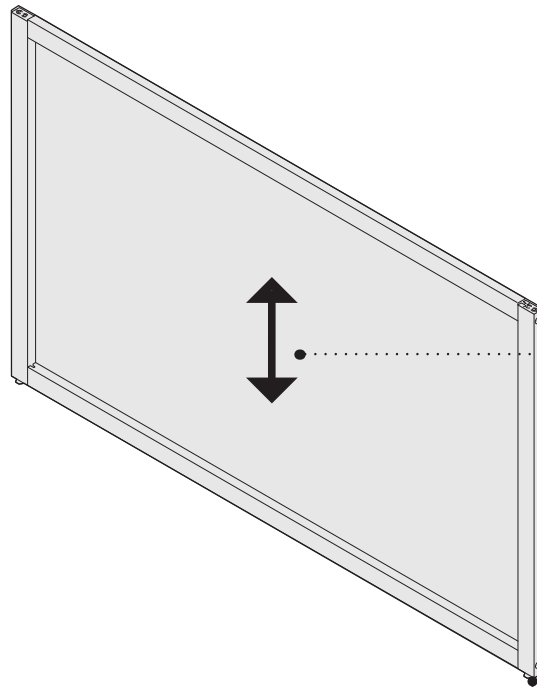

Directional laminate is vertical on screen infills.

Leveling glides adjust 1/2" to accommodate uneven floors.

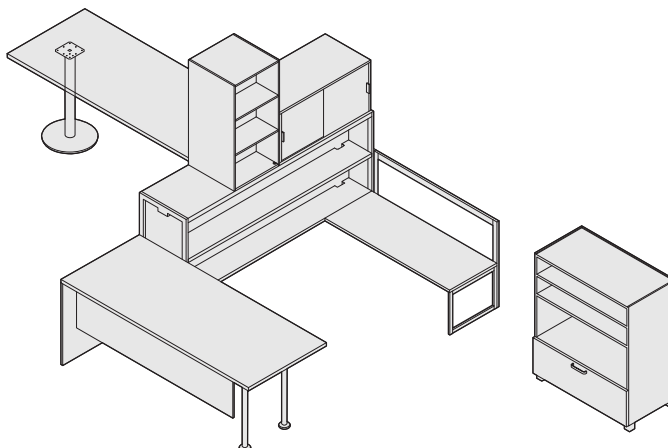

Screen connectors are steel components that facilitate the attachment of screens in different configurations. Brackets are ordered separately.

 Specifying, pages 95–96

Two-way same height (Inline or L-configuration, TSTPBSH2)

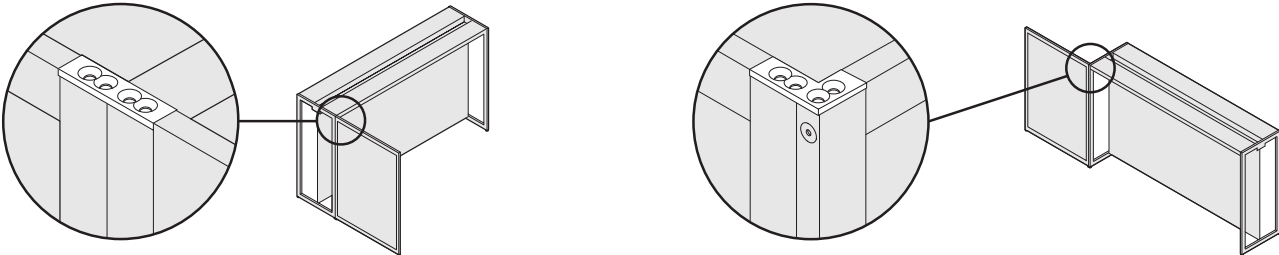

Three-way same height (T-configuration, TSTPBSH3)

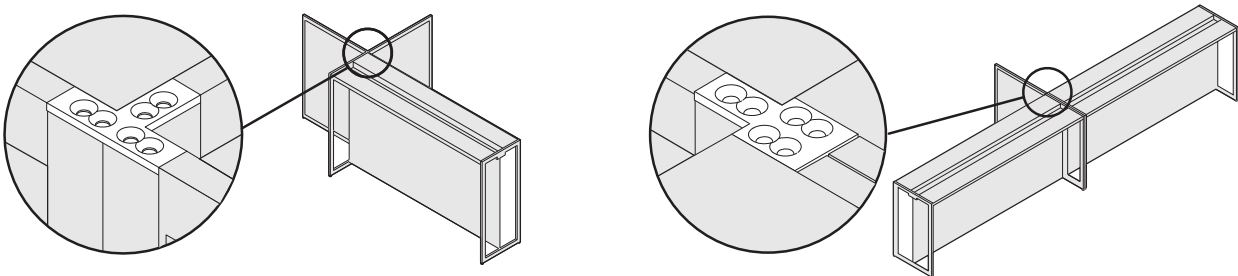

Two-way change-of-height (Inline or L-configuration, TSTPBCOH2)

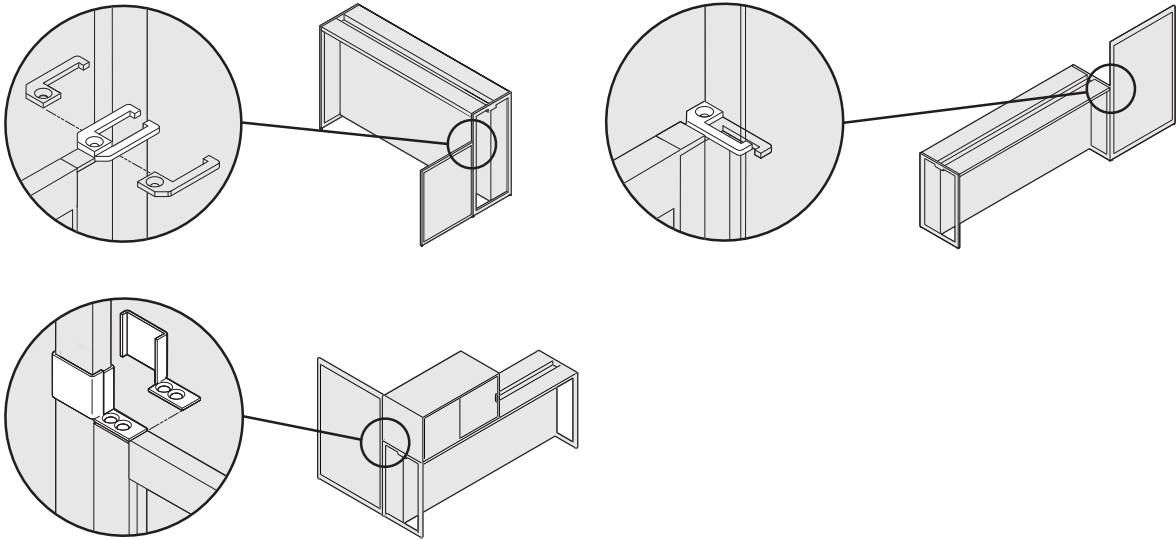

Screen and Screen Connector Facts, continued

 Specifying, pages 95–96

Three-way change-of-height (T-configuration, TSTPBCOH3)

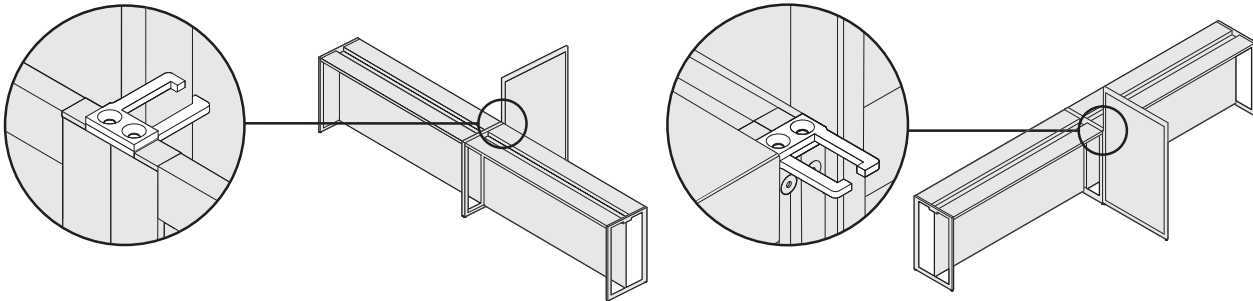

Two-way same height (120° configuration, TSTPB120)

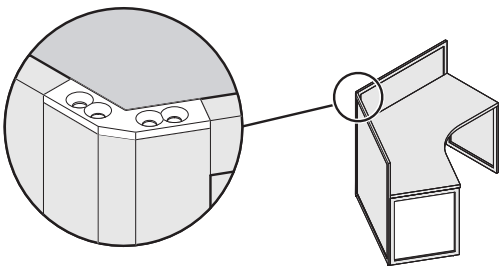

* Two-way 120° brackets can only be used when both screens are at the same height.

Three-way same height (120° configuration, TSTPB120Y)

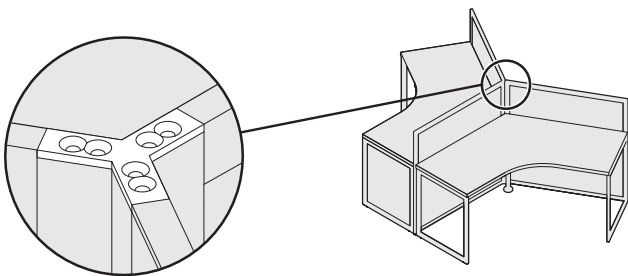

* Three-way 120° brackets can only be used when all screens are at the same height.

Worksurface-to-screen (TSTPBWT)

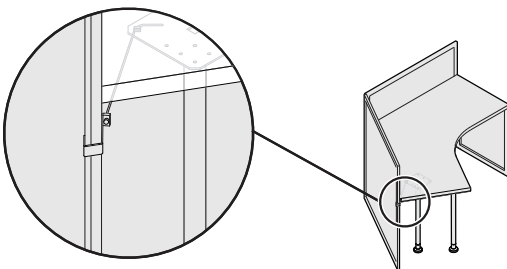

* Worksurface-to-screen tie draws the screen tighter to the worksurface when at the end of a configuration.

Freestanding Screen Stability Rules

 Specifying, pages 95–96

U-configuration with two screens

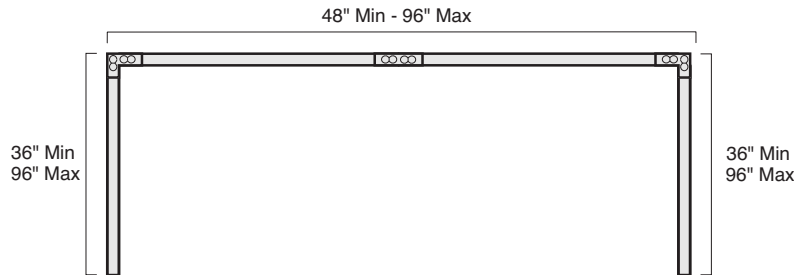

L-configuration with two screens

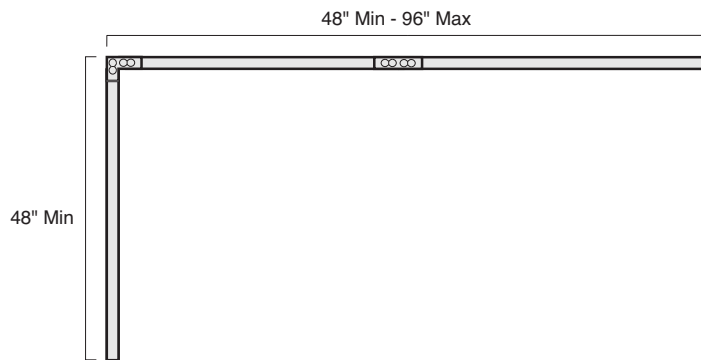

L-configuration with one screen

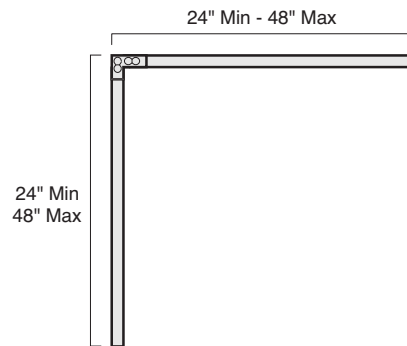

T-configuration

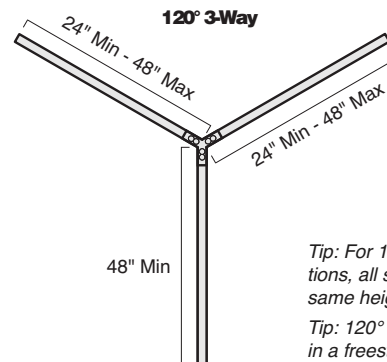
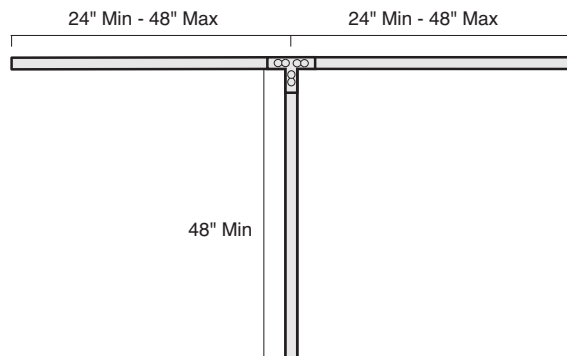

Tip: For 120° screen applications, all screens must be the same height.

Tip: 120° 2-way not available in a freestanding application.

HV Cabinet Facts

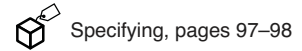

Specifying, pages 97–98

HV cabinet is a steel cabinet with a laminate center divider and a 7" D steel shelf. The HV cabinet is designed to sit on its side or end on a counter or on its side on a pile file. Two cabinets laid on their side fit on a counter, and take the place of a countertop.

Tip: HV cabinet center divider laminate color number defaults based on the paint selection.

▶ Page 106

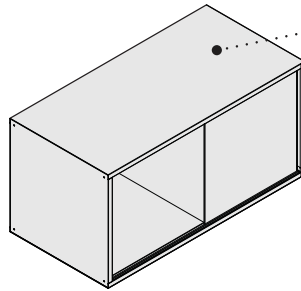

Shared HV cabinet gives users on both sides one 18"D x 18"W cube for storage. Available open or with the option of a door on each side. The shared HV cabinet is a steel cabinet with a steel center divider, but it does not have a 7" D steel shelf.

Sliding doors with pulls are optional on the HV cabinet and can be ordered as a single or double door. Sliding doors can be ordered in laminate. Optional doors do not lock.

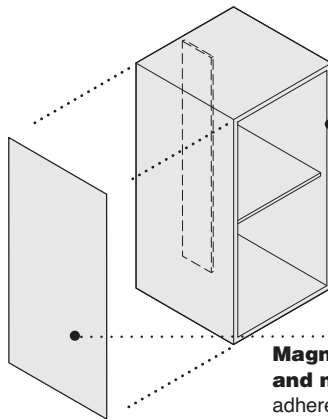

HV cabinet
without doors

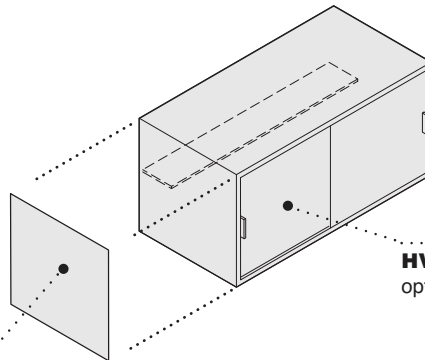

HV cabinet shown with optional laminate doors.

Magnetic markerboard and magnetic tackboard adhere to steel sides and backs of HV cabinet for user-friendly writing surface, notes, and pictures.

Horizontal/vertical cabinets ship fully assembled.

For stability, if three HV cabinets are placed on top of a counter, one of the HV cabinets must be on its side.

Up to three HV cabinets can be placed on top of one counter.

For stability, the HV cabinet comes with four small screws to attach the HV cabinet to the counter for the following conditions:

- When the HV cabinet is in a vertical position in a seismic zone.
- When the HV cabinet is in a vertical position without another HV cabinet next to it.

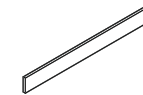
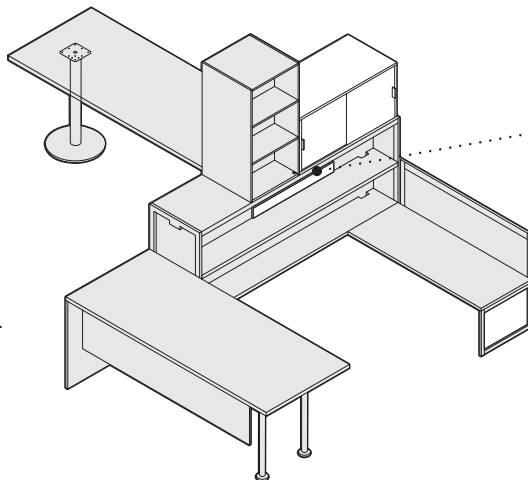

Magnetic tackboard strip is 2 1/2"H x 22"W and fits on front of counter and underneath on the center infill.

Bookcase Facts

Shared bookcase is a laminate cabinet with a center divider between the front and back; and two fixed shelves on each side. Primary use is a shared component between users on opposite sides of counter. The shared bookcase is designed to sit on it's side or end, on a counter, or on it's side on a pile file. A bookcase takes the place of countertops.

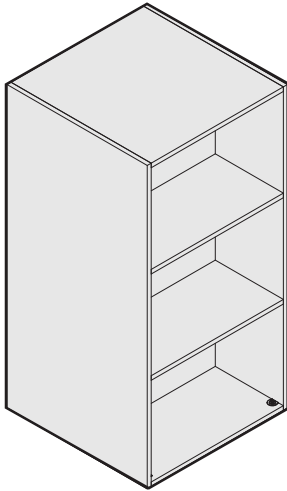

 Specifying, page 99

Personal bookcase is a one-sided laminate cabinet with one fixed shelf. Primary use is as a personal bookcase accessible from one side of a counter. If used on a counter, two personal bookcases must be ordered and placed back-to-back to take the place of one 18"W x 18"W countertop.

A personal bookcase can be specified with optional feet for use at the bottom of a counter. Includes a bracket to connect to bottom horizontal frame of counter.

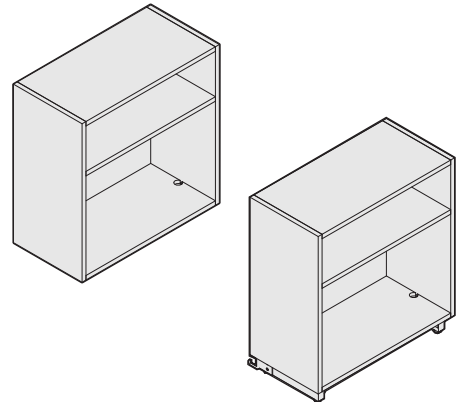

Shared bookcase and personal bookcase ship fully-assembled. Optional feet for personal bookcase must be field-assembled.

Possible Configurations of HV Cabinets and Bookcases

Two personal bookcases (placed back-to-back) can replace one HV cabinet or shared bookcase in the vertical position.

No more than three HV cabinets or shared bookcases may be placed on a single counter. When three components are placed on a single counter, one component **MUST** be laying on it's 36"W side.

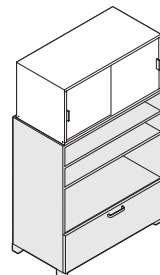
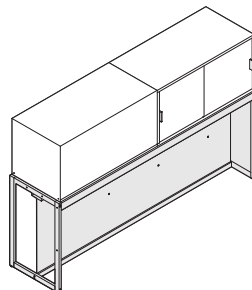
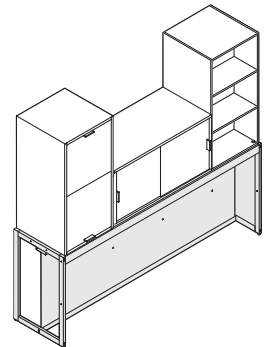
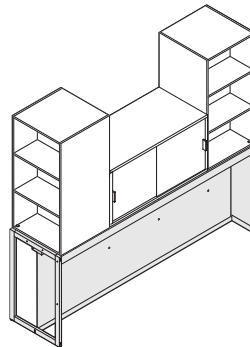
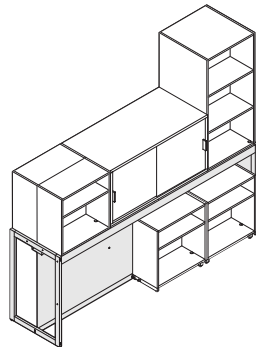

A single HV cabinet or shared bookcase can be mounted in a horizontal position on top of a pile file.

My File Facts

 Specifying, pages 100–101

My file is constructed of laminate sides and drawer front with steel drawer body. My file has a full 22" of functional depth. Back of drawer has metal box with an open floor and accommodates suspended side-to-side letter filing. Front of drawer has an unique 9" x 18" storage cubby to store personal items.

Back of drawer has metal box with an open floor and accommodates suspended side-to-side letter filing.

Top is open to attach beneath a worksurface. A 6" minimum of worksurface is required beyond the footprint of the file to attach to the counter shelf. Example: if (2) two my files are used $18" + 18" = 36"$, a 42" worksurface or longer must be used.

Drawer has an optional front-removable lock.

Ledge pull is standard on the my file.

Front of drawer has a unique 9" x 18" storage cubby to store personal items.

Freestanding configuration cannot be used with my files. It must be at the opposite end of a worksurface that is attached to a counter shelf.

Lateral file cushion is used on top of a worksurface over my file or worksurface frame support.

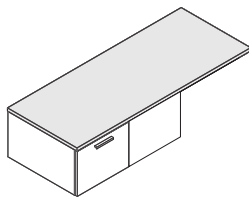
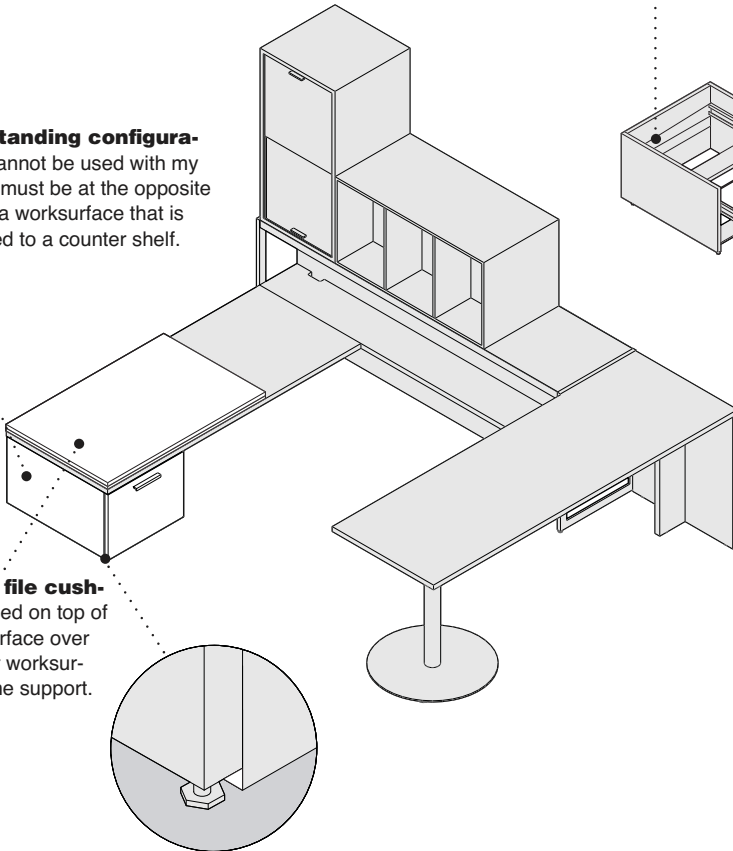

My file can be installed in opposite directions to accommodate two users.

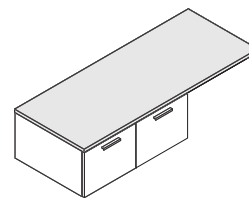

My file can be installed side-by-side for twice the storage and filing capability.

Multiple my files can be installed next to one another facing the same direction or in opposite directions just as long as there is 6" minimum open worksurface left to attach to the counter shelf.

Pile File Facts

Pile file is constructed of laminate sides and drawer front with a steel back and top. Two pullout laminate shelves and a full-size lateral file drawer provide storage and user flexibility.

 Specifying, page 102

Ledge pull is standard on the lateral file drawer.

Two 18"W or one 36"W countertop nestle into the top of a pile file to provide a flush surface. Countertops are ordered separately.

Lateral file drawer accommodates letter-size side-to-side filing. For legal-size front-to-back filing, use 15" universal storage rail RXADRL15.

Lateral file drawer has an optional front-removable lock.

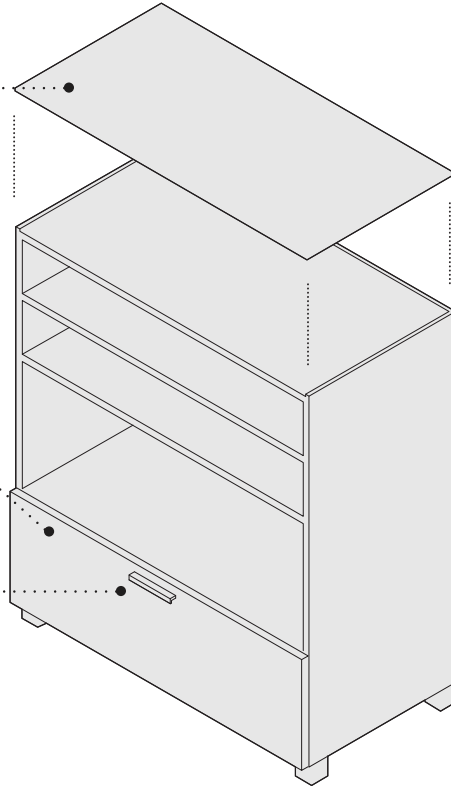

Pile file top and back can be covered with a magnetic markerboard or tackboard for a user-friendly writing surface.

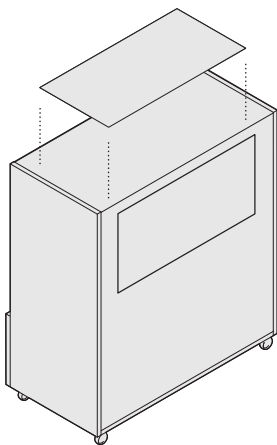

Optional casters allow for mobility.

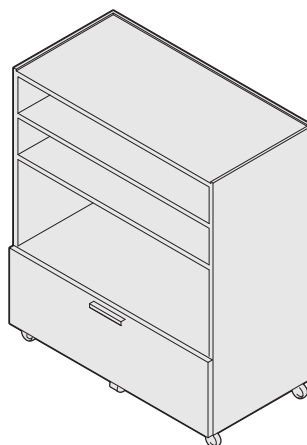

Top of pile file can be left open or accommodate a HV cabinet.

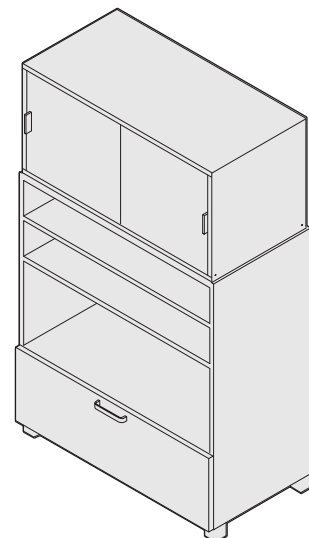

Counters

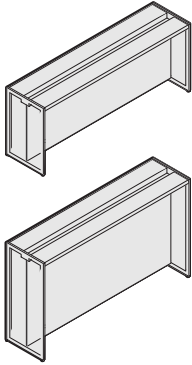

Tip: Woodgrain laminate runs horizontal on the counter center infill and vertically on the optional end panel infills.

Tip: Optional power does not include base-in. Refer to electrical components for more information on page 70.

Tip: For 2-circuit or 4-circuit power, refer to electrical components on page 70.

Standard Includes	Required to Specify
-------------------	---------------------

- | | | |
|---|--|---|
| <ul style="list-style-type: none"> ▶ Need help? Product details, page 43 | <ul style="list-style-type: none"> • Counter top tray: paint price group 1 • Counter frame support: Clear Anodized Aluminum • Center infill: laminate • Adjustable leveling glides • Counter-to-counter attachment hardware: 4799 Platinum • Shipped ready to assemble | <ul style="list-style-type: none"> 1 Style number 2 Paint color number for counter top tray 3 Laminate color number for center infill 4 Options, if selected (see below) ▶ See <i>Surface Materials</i>, page 106. |
|---|--|---|

Options	U.S. Price	Required to Specify
---------	------------	---------------------

Surface Materials	Counter top tray		
	• Paint price group 1	No cost	Specify paint color number.
	• Paint price group 2	+\$ 30	Specify paint color number.
	Steel center infill		
	• Paint price group 1	30"H +\$208	Specify paint color number.
	• Paint price group 2	30"H +\$257	Specify paint color number.
	• Paint price group 1	42"H +\$312	Specify paint color number.
	• Paint price group 2	42"H +\$361	Specify paint color number.
	End panel infill (both ends)		
	• Laminate	30"H +\$ 78	Specify laminate color number.
• Laminate	42"H +\$104	Specify laminate color number.	
Electrical	Factory-installed powerway		
	• 1-circuit power	+\$187	Specify with 1-circuit power.
Related Products	• Countertops		▶ Page 69
	• Electrical components		▶ Page 70
	• Magnetic tackboard		▶ Page 103

Specification Information

• Dimensions			• Style Number	• U.S. Base Price
D	W	H		
18"	72"	30"	TSTMC3072	\$ 915
18"	72"	42"	TSTMC4272	\$1030



For Canadian Pricing
 Multiply U.S. Price by the Canadian price factor.
 ▶ See page 1 for details.

Standard Includes	Required to Specify
<ul style="list-style-type: none"> ▶ Need help? Product details, page 43 • Countertop: laminate • Shipped ready to assemble 	<ul style="list-style-type: none"> 1 Style number 2 Laminate color number for countertop ▶ See <i>Surface Materials</i>, page 106.

Related Products
<ul style="list-style-type: none"> • Counters

▶ Page 68

Specification Information

• Dimensions	• Style	• U.S.
D W	Number	Price

Countertops			
18"	18"	TSTMCT1818	\$ 52
18"	36"	TSTMCT1836	\$ 86
18"	54"	TSTMCT1854	\$114
18"	72"	TSTMCT1872	\$160
:	:	:	:

Notched Countertops			
18"	18"	TSTMCTN1818	\$ 57
18"	36"	TSTMCTN1836	\$ 92
18"	54"	TSTMCTN1854	\$121
18"	72"	TSTMCTN1872	\$166
:	:	:	:

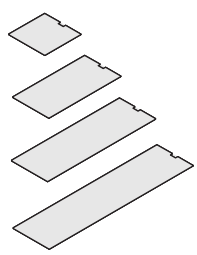
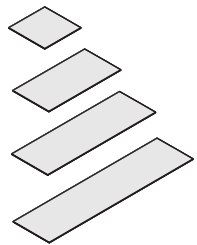

For Canadian Pricing
 Multiply U.S. Price by the Canadian price factor.
 ▶ See page 1 for details.

Electrical Components

Base Power-Ins

	Standard Includes	Required to Specify
<p>► Need help? Product details, page 44</p>	<ul style="list-style-type: none"> • Receptacle base power-in, 24" long cord with wall plug • 1-circuit or 2-circuit hardwired base power-in, 94" long x 3/8" diameter flexible galvanized steel conduit • Modular connection for 1-circuit or 2-circuit powerway • In-line connector to allow connection at middle of run • 4-circuit hardwired base power-in <ul style="list-style-type: none"> - One hardwired base power-in with Line 1 and Line 2 receptacle, and a 94" long x 3/8" diameter flexible galvanized steel conduit - One hardwired base power-in with Line 3 and Line 4 receptacle, and a 124" long x 3/8" diameter flexible galvanized steel conduit 	<p>Style number</p>

Related Products
<ul style="list-style-type: none"> • Powerways

► Page 72

Specification Information		
Counter Height	Style Number	U.S. Price
:	:	:

Receptacle Base Power-In, 1-Circuit, Line 1 Only

30"	TSTEPBR130	\$104
42"	TSTEPBR142	\$114
:	:	:

Hardwired Base Power-In, 1-Circuit or 2-Circuit, Line 1 and Line 2

94"	TSTEPBT2	\$104
:	:	:

San Francisco Base Power-In, 1-Circuit or 2-Circuit, Line 1 and Line 2

30"	TSTEPBT230SF	\$130
42"	TSTEPBT242SF	\$130
:	:	:

► Specification Information, continued on next page

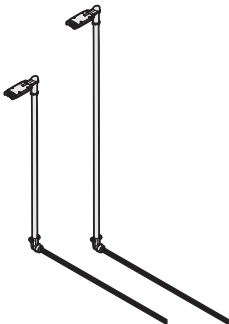
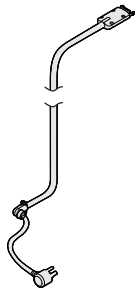

► Specification Information, continued from previous page

Specification Information

Counter Height	Style Number	U.S. Price
----------------	--------------	------------

Hardwired Base Power-In, 4-Circuit, Line 1 and Line 2, Line 3 and Line 4

94", 124"	TSTEPBT4	\$260
-----------	-----------------	-------

San Francisco Base Power-In, 4-Circuit, Line 1 and Line 2, Line 3 and Line 4

30"	TSTEPBT430SF	\$104
42"	TSTEPBT442SF	\$104

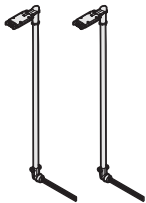

For Canadian Pricing
 Multiply U.S. Price by the Canadian price factor.
 ► See page 1 for details.

Powerways

Tip: Power runs through spine of counter and is "plug-and-play".

Standard Includes	Required to Specify
<ul style="list-style-type: none"> ▶ Need help? Product details, page 44 	<ul style="list-style-type: none"> • 72" powerway with four duplex receptacles for 1-circuit and 2-circuit powerways: 6000 black • 72" powerway for 4-circuit with (1) Line 1 and (1) Line 2 receptacle, and (1) Line 3 and (1) Line 4 receptacle • Shipped ready to install

Related Products
<ul style="list-style-type: none"> • Counters ▶ Page 68

Specification Information

• Style Number	• U.S. Price

1-Circuit Powerway - Line 1 Only

TSTEP172	\$187

2-Circuit Powerway - Line 1 and Line 2

TSTEP272	\$224

4-Circuit Powerway - Line 1 and Line 2 Receptacle, Line 3 and Line 4 Receptacle

TSTEP472	\$177

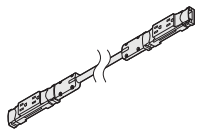

Tip: Conduit comes from the base power-in.

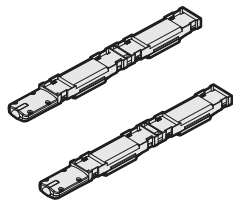

For Canadian Pricing

Multiply U.S. Price by the Canadian price factor.

▶ See page 1 for details.

Counter-to-Counter Power Connector, 1-Circuit and 2-Circuit

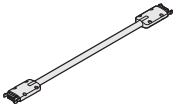

Standard Includes	Required to Specify
<ul style="list-style-type: none"> ▶ Need help? Product details, page 44 • Modular counter-to-counter power connector 	Style number

Related Products
<ul style="list-style-type: none"> • Counters ▶ Page 68 • Powerways ▶ Page 72

Specification Information	
Style Number	U.S. Price
TSTEPC2C	\$62

Counter-to-Counter Power Connector, 4-Circuit

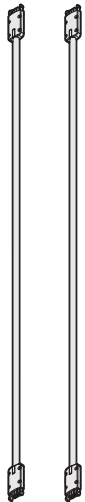

Standard Includes	Required to Specify
<ul style="list-style-type: none"> ▶ Need help? Product details, page 44 • Modular counter-to-counter power connector 	Style number

Related Products
<ul style="list-style-type: none"> • Counters ▶ Page 68 • Powerways ▶ Page 72

Specification Information	
Style Number	U.S. Price
TSTEPC2C4	\$146



For Canadian Pricing
 Multiply U.S. Price by the Canadian price factor.
 ▶ See page 1 for details.

Power Jumper, 1-Circuit and 2-Circuit

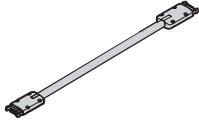

Tip: Power jumpers ship with one or two horizontal cord managers, TSTECW, depending on the length of the power jumper.

Standard Includes	Required to Specify
<ul style="list-style-type: none"> ▶ Need help? Product details, page 50 • Modular counter-to-counter power jumper • Horizontal wire manager: black plastic • Attachment hardware 	<ul style="list-style-type: none"> Style number

Related Products	
<ul style="list-style-type: none"> • Counters • Powerways 	<ul style="list-style-type: none"> ▶ Page 68 ▶ Page 72

Specification Information

Length	Style Number	U.S. Price
69"	TSTEP2C069	\$208
75"	TSTEP2C075	\$208
81"	TSTEP2C081	\$208
87"	TSTEP2C087	\$208
93"	TSTEP2C093	\$208
99"	TSTEP2C099	\$208
105"	TSTEP2C105	\$208
111"	TSTEP2C111	\$208
117"	TSTEP2C117	\$208
120"	TSTEP2C120	\$208
123"	TSTEP2C123	\$208
126"	TSTEP2C126	\$208
129"	TSTEP2C129	\$208
132"	TSTEP2C132	\$208
135"	TSTEP2C135	\$208
138"	TSTEP2C138	\$208
141"	TSTEP2C141	\$208
144"	TSTEP2C144	\$208
147"	TSTEP2C147	\$208
150"	TSTEP2C150	\$208
153"	TSTEP2C153	\$208
156"	TSTEP2C156	\$208
159"	TSTEP2C159	\$208
162"	TSTEP2C162	\$286
165"	TSTEP2C165	\$286
168"	TSTEP2C168	\$286
171"	TSTEP2C171	\$286
174"	TSTEP2C174	\$286

▶ **Specification Information, continued on next page**



For Canadian Pricing
 Multiply U.S. Price by the Canadian price factor.
 ▶ See page 1 for details.

► Specification Information, continued from previous page

Specification Information

Length	Style Number	U.S. Price
177"	TSTEP2C177	\$286
180"	TSTEP2C180	\$286
183"	TSTEP2C183	\$286
186"	TSTEP2C186	\$286
189"	TSTEP2C189	\$286
192"	TSTEP2C192	\$286
195"	TSTEP2C195	\$286
198"	TSTEP2C198	\$286
201"	TSTEP2C201	\$312
204"	TSTEP2C204	\$312
207"	TSTEP2C207	\$312
210"	TSTEP2C210	\$312
213"	TSTEP2C213	\$312
216"	TSTEP2C216	\$312
219"	TSTEP2C219	\$312
222"	TSTEP2C222	\$312
225"	TSTEP2C225	\$312
228"	TSTEP2C228	\$312
:	:	:

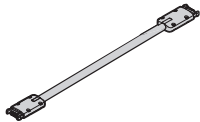

Tour Workspace

For Canadian Pricing
 Multiply U.S. Price by the
 Canadian price factor.
 ► See page 1 for details.

Power Jumper, 4-Circuit

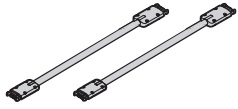

Tip: Power jumpers ship with one or two horizontal cord managers, TSTECW, depending on the length of the power jumper.

Standard Includes	Required to Specify
<ul style="list-style-type: none"> ▶ Need help? Product details, page 50 • Modular counter-to-counter power jumpers • Horizontal wire manager: black plastic • Attachment hardware 	<ul style="list-style-type: none"> Style number

Related Products	
<ul style="list-style-type: none"> • Counters • Powerways 	<ul style="list-style-type: none"> ▶ Page 68 ▶ Page 72

Specification Information

Length	Style Number	U.S. Price
96"	TSTEP4C096	\$390
102"	TSTEP4C102	\$390
108"	TSTEP4C108	\$390
114"	TSTEP4C114	\$390
120"	TSTEP4C120	\$390
126"	TSTEP4C126	\$390
132"	TSTEP4C132	\$390
138"	TSTEP4C138	\$390
144"	TSTEP4C144	\$390
147"	TSTEP4C147	\$390
150"	TSTEP4C150	\$390
153"	TSTEP4C153	\$390
156"	TSTEP4C156	\$390
159"	TSTEP4C159	\$390
162"	TSTEP4C162	\$468
165"	TSTEP4C165	\$468
168"	TSTEP4C168	\$468
171"	TSTEP4C171	\$468
174"	TSTEP4C174	\$468
177"	TSTEP4C177	\$468
180"	TSTEP4C180	\$468
183"	TSTEP4C183	\$468
186"	TSTEP4C186	\$468
189"	TSTEP4C189	\$468
192"	TSTEP4C192	\$468
195"	TSTEP4C195	\$468
198"	TSTEP4C198	\$468
...

▶ **Specification Information, continued on next page**

For Canadian Pricing
 Multiply U.S. Price by the Canadian price factor.
 ▶ See page 1 for details.

► Specification Information, continued from previous page

Specification Information

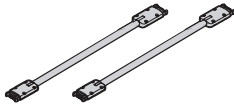

Length	Style Number	U.S. Price
201"	TSTEP4C201	\$494
204"	TSTEP4C204	\$494
207"	TSTEP4C207	\$494
210"	TSTEP4C210	\$494
213"	TSTEP4C213	\$494
216"	TSTEP4C216	\$494
219"	TSTEP4C219	\$494
222"	TSTEP4C222	\$494
225"	TSTEP4C225	\$494
228"	TSTEP4C228	\$520
231"	TSTEP4C231	\$520
234"	TSTEP4C234	\$520
237"	TSTEP4C237	\$520
240"	TSTEP4C240	\$520
243"	TSTEP4C243	\$520
246"	TSTEP4C246	\$520
249"	TSTEP4C249	\$520
252"	TSTEP4C252	\$520
255"	TSTEP4C255	\$520
:	:	:

Tour Workspace



For Canadian Pricing
Multiply U.S. Price by the Canadian price factor.
► See page 1 for details.

Worksurface-Height Power and Communication Access

Worksurface Clamp-On Receptacle Packages



Tip: Tour clamp-on accessories work on surfaces 3/4" to 1 1/4" thick. They do not work on surfaces over 1 1/4" thick.

Standard Includes	Required to Specify
<ul style="list-style-type: none"> ▶ Need help? Product details, page 55 • Package of three • Duplex receptacles: black plastic only • 9' cord with three-prong plug: black plastic only 	Style number

Specification Information

Style Number	U.S. Price
TSTERPW	\$145

Worksurface Clamp-On Communication Module Packages

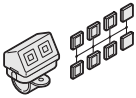

Tip: Many of the AMP, AT&T, Krone, Leviton, and other commercially available data terminals can be used—terminals must be of a design that will snap into 0.695 x 0.650, 0.590 x 0.790, or 0.590 x 0.750 openings, in 0.064 maximum thick faceplates.

Tip: Order jacks by calling any of the manufacturers listed below:

- AMP Corporation
1.800.522.6752
- Leviton
1.800.722.2082
- Lucent
1.800.344.0223
- Krone
1.800.775.5766
- Punduit
1.800.777.3300

Tip: Tour clamp-on accessories work on surfaces 3/4" to 1 1/4" thick. They do not work on surfaces over 1 1/4" thick.

Standard Includes	Required to Specify
<ul style="list-style-type: none"> ▶ Need help? Product details, page 55 • Package of three • Communication housing includes faceplates to accommodate customer-supplied voice/data jacks: black plastic only 	Style number

Specification Information

Style Number	U.S. Price
TSTERDW	\$95

Worksurface-Mounted Power and Communication Sphere

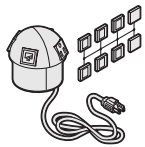

Tip: Sphere is field installed. Use 3"-diameter drill to cut mounting hole at desired location.

Tip: Order jacks by calling any of the manufacturers listed below:

- AMP Corporation
1.800.522.6752
- Leviton
1.800.722.2082
- Lucent
1.800.344.0223
- Krone
1.800.775.5766
- Punduit
1.800.777.3300

Standard Includes	Required to Specify
<ul style="list-style-type: none"> ▶ Need help? Product details, page 54 • Sphere with two simplex electrical outlets: black plastic • Faceplates to accommodate two customer-supplied voice/data jacks: black plastic • 6' power cord with three-prong plug: black plastic 	<ul style="list-style-type: none"> Style number

Specification Information	
• Style Number	• U.S. Price
TSTERPDWD	\$200

Horizontal Cord Manager

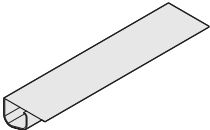

Standard Includes	Required to Specify
<ul style="list-style-type: none"> ▶ Need help? Product details, page 54 • Horizontal cord manager: 6000 Black plastic • Attachment hardware 	<ul style="list-style-type: none"> Style number

Related Products	
<ul style="list-style-type: none"> • Worksurfaces • Shelves 	<ul style="list-style-type: none"> ▶ Page 85 ▶ Page 93

Specification Information		
• Dimension W	• Style Number	• U.S. Price
56"	TSTECM	\$23

For Canadian Pricing
Multiply U.S. Price by the Canadian price factor.
▶ See page 1 for details.

Mesh Cable Bag

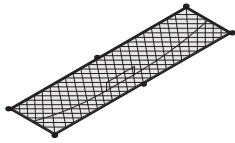

Tip: Mesh cable bag is most effective when stretched to the full 48" during installation.

Standard Includes	Required to Specify
<ul style="list-style-type: none"> ▶ Need help? Product details, page 55 • Mesh cable bag • Attachment hardware 	<ul style="list-style-type: none"> Style number

Related Products
<ul style="list-style-type: none"> • Worksurfaces ▶ Page 85 • Shelves ▶ Page 93

Specification Information			
• Dimension	• Style	• U.S.	
W L	Number	Price	
24"	48"	TSTECB	\$62

Worksurface Clamp-On Power and Data

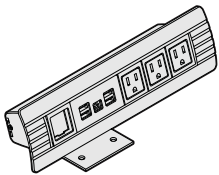

Tip: Tour clamp-on accessories work on surfaces 3/4" to 1 1/4" thick. They do not work on surfaces over 1 1/4" thick.

Standard Includes	Required to Specify
<ul style="list-style-type: none"> ▶ Need help? Product details, page 55 • Worksurface-mounted power and data openings • 10' power cord with three-prong plug: black plastic • Four power receptacles, two data openings, and faceplates provided to accommodate customer-supplied voice/data jacks • Duplex receptacles: black plastic only • Surrounding housing: anodized aluminum 	<ul style="list-style-type: none"> 1 Style number 2 Options, if selected (see below)

Options	U.S. Price	Required to Specify
Power/Data/USB Hub		
• 2 power, 2 data, and 1 USB Hub	+\$ 78	Specify with 2 power + 2 data + 1 USB hub
• 3 power, 1 data, and 1 USB Hub	+\$104	Specify with 3 power + 1 data + 1 USB hub

Related Products	
<ul style="list-style-type: none"> • Counters • Powerways 	<ul style="list-style-type: none"> ▶ Page 68 ▶ Page 72

Specification Information	
• Style	• U.S.
Number	Base Price
TSTECLAMP	\$364



For Canadian Pricing
 Multiply U.S. Price by the Canadian price factor.
 ▶ See page 1 for details.

Worksurface-Mounted Retractable Power and Data

Field-Installed Cut-Out

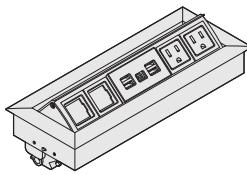

Tip: Worksurface-mounted retractable power and data requires a 4" x 11" hole with square corners in the worksurface.

Standard Includes	Required to Specify
-------------------	---------------------

- | | | |
|---|--|--|
| <ul style="list-style-type: none"> ▶ Need help? Product details, page 54 | <ul style="list-style-type: none"> • Worksurface-mounted power and data openings • 10' power cord with three-prong plug: black plastic • Four power receptacles, two data openings, and faceplates provided to accommodate customer-supplied voice/data jacks • Duplex receptacles: black plastic only • Surrounding housing: anodized aluminum | <ul style="list-style-type: none"> 1 Style number 2 Options, if selected (see below) |
|---|--|--|

Options	U.S. Price	Required to Specify
---------	------------	---------------------

- | | | |
|---------------------------|--|--|
| Power/Data/USB Hub | <ul style="list-style-type: none"> • 2 power, 2 data, and 1 USB Hub +\$ 78 • 3 power, 1 data, and 1 USB Hub +\$104 | <ul style="list-style-type: none"> Specify with 2 power + 2 data + 1 USB hub Specify with 3 power + 1 data + 1 USB hub |
|---------------------------|--|--|

- | | | |
|-------------------------|---|--|
| Related Products | <ul style="list-style-type: none"> • Counters • Powerways | <ul style="list-style-type: none"> ▶ Page 68 ▶ Page 72 |
|-------------------------|---|--|

Specification Information		
---------------------------	--	--

Style Number	U.S. Base Price
TSTERPDWR	\$390

Vertical Cord Cover



Tip: There are three knock-outs in the 30" and 42" vertical wire managers (TSTECC30 and TSTECC42). The first and third are available to route Tour power jumpers and the second is standard Decora-size to fit data ports, approximately 1 3/8"W x 2 5/8"H (actual dimensions 1.310"W x 2.687"H).

Standard Includes	Required to Specify
-------------------	---------------------

- | | |
|---|---|
| <ul style="list-style-type: none"> • Vertical cord cover: paint price group 1 • Attachment hardware | <ul style="list-style-type: none"> 1 Style number 2 Paint color number for vertical cord cover 3 Options, if selected (see below) ▶ See <i>Surface Materials</i>, page 106. |
|---|---|

Options	U.S. Price	Required to Specify
---------	------------	---------------------

- | | | |
|--------------------------|--|--|
| Surface Materials | <ul style="list-style-type: none"> • Paint price group 1 No cost • Paint price group 2 +\$16 | <ul style="list-style-type: none"> Specify paint color number. Specify paint color number. |
|--------------------------|--|--|

- | | | |
|-------------------------|--|--|
| Related Products | <ul style="list-style-type: none"> • Counters • Vertical cord cover grommet insert | <ul style="list-style-type: none"> ▶ Page 68 ▶ Page 82 |
|-------------------------|--|--|

Specification Information			
---------------------------	--	--	--

Dimensions			Style Number	U.S. Base Price
D	W	H		
7/8"	2 3/4"	30"	TSTECC30	\$42
7/8"	2 3/4"	42"	TSTECC42	\$52

For Canadian Pricing
Multiply U.S. Price by the Canadian price factor.
▶ See page 1 for details.

Vertical Cord Cover Grommet Insert



Standard Includes	Required to Specify
<ul style="list-style-type: none"> ▶ Need help? Product details, page 54 • Package of 5 grommet inserts: plastic 	<ul style="list-style-type: none"> 1 Style number 2 Plastic color number for grommet insert ▶ See <i>Surface Materials</i>, page 106.

Related Products
<ul style="list-style-type: none"> • Vertical cord cover ▶ Page 81

Specification Information	
• Style Number	• U.S. Price
TSTEGC	\$23
•	•

 **For Canadian Pricing**
 Multiply U.S. Price by the Canadian price factor.
 ▶ See page 1 for details.

Bench Components

Bench Trough

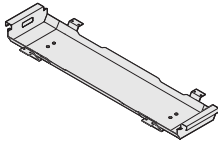

Standard Includes		Required to Specify
<ul style="list-style-type: none"> ▶ Need help? Product details, page 52 	<ul style="list-style-type: none"> • Steel telescoping bench trough: paint price group 1 • Attachment hardware 	<ul style="list-style-type: none"> 1 Style number 2 Paint color number 3 Options, if selected (see below) ▶ See <i>Surface Materials</i>, page 106.

Options	U.S. Price	Required to Specify
Surface Materials <ul style="list-style-type: none"> • Paint price group 1 • Paint price group 2 	No cost +\$41	Specify paint color number. Specify paint color number.

Related Products <ul style="list-style-type: none"> • Worksurfaces 	▶ Page 85
--	-----------

Specification Information				
Dimensions			Style Number	U.S. Base Price
D	W	L		
43/8"	12"	60"—72"	TSTECBT	\$624

Bench Screen

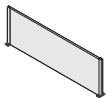

Standard Includes		Required to Specify
<ul style="list-style-type: none"> ▶ Need help? Product details, page 52 	<ul style="list-style-type: none"> • Steel bench screen: paint price group 1 • Attachment hardware 	<ul style="list-style-type: none"> 1 Style number 2 Paint color number 3 Options, if selected (see below) ▶ See <i>Surface Materials</i>, page 106.

Options	U.S. Price	Required to Specify
Surface Materials <ul style="list-style-type: none"> • Paint price group 1 • Paint price group 2 	No cost +\$41	Specify paint color number. Specify paint color number.

Related Products <ul style="list-style-type: none"> • Worksurfaces 	▶ Page 85
--	-----------

Specification Information			
Dimensions		Style Number	U.S. Base Price
W	H		
48"	22"	TSTECBDP	\$416

 **For Canadian Pricing**
 Multiply U.S. Price by the Canadian price factor.
 ▶ See page 1 for details.

SOTO Tour Rails

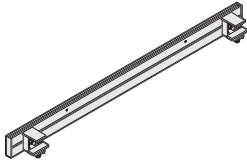

Tip: Allow 1" clearance between worksurface and rail for cable management. Allow 2" for rail mount installed behind a worksurface, and 3¾" overall to install the rail.

Tip: Maximum weight load rails are 2 lbs per linked inch.

Tip: Each clamp requires a 2" footprint above the worksurface, and a 3¼" clearance below the worksurface.

Tip: Tour rails clamp to Tour bench troughs. Rails are not applicable for glass surfaces.

Standard Includes

- Rail: 4799 Platinum

Required to Specify

Style number

Related Products

- SOTO shelves
- SOTO Worktools

- ▶ Page 228
- ▶ Page 233

Specification Information

Corresponding Table Top Width	Dimensions			Style Number	U.S. Price
	D	W	H		
60"	1"	52"	3¼"	DSRT52	\$218
66"	1"	58"	3¼"	DSRT58	\$230
72"	1"	64"	3¼"	DSRT64	\$240
.



For Canadian Pricing

Multiply U.S. Price by the Canadian price factor.

▶ See page 1 for details.

Worksurfaces

Straight

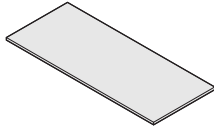

Standard Includes	Required to Specify
<ul style="list-style-type: none"> ▶ Need help? Product details, page 56 • 1 1/8"-thick worksurface: Low-Pressure Laminate or High-Pressure Laminate • 3 mm radius profile edge on both user's edges: plastic • 1 mm side edges: plastic default to match user's edges • Shipped ready to install 	<ol style="list-style-type: none"> 1 Style number 2 Low-Pressure Laminate or High-Pressure Laminate color number for worksurface 3 Plastic edge band color number for worksurface 4 Options, if selected (see below) <ul style="list-style-type: none"> ▶ See <i>Surface Materials</i>, page 106

Options	U.S. Price	Required to Specify
Surface Materials <ul style="list-style-type: none"> • High-Pressure Laminate worksurfaces • Open Line laminate 	+\$64 plus cost of laminate	<ul style="list-style-type: none"> ▶ See <i>Surface Materials Reference Manual</i>.
Related Products <ul style="list-style-type: none"> • Worksurface supports • Modesty panels • Reinforcing channel 		<ul style="list-style-type: none"> ▶ Page 90 ▶ Page 94 ▶ Page 92

Tip: Reinforcing channel (TSATRC57) is required to add support to worksurfaces that have 60" or more of unsupported kneespace.
 ▶ Page 92

Tip: Standard worksurfaces are 1 1/8" thick. However, the actual thickness between Low-Pressure Laminate (LPL) and High-Pressure Laminate (HPL) worksurfaces is slightly different. It is recommended that only worksurfaces of the same type are specified in a given application. In addition, there may be sheen or texture differences when using LPL and HPL in adjacent applications. Please use caution when mixing and matching different worksurface types.

Specification Information				
Dimensions	Style Number	U.S. Price	Style Number	U.S. Base Price
D	W	LPL	HPL	Price

Worksurfaces					
18"	42"	TSTWLR1842	\$133	TSTWHR1842	\$180
18"	48"	TSTWLR1848	\$145	TSTWHR1848	\$192
18"	54"	TSTWLR1854	\$173	TSTWHR1854	\$220
24"	36"	TSTWLR2436	\$129	TSTWHR2436	\$176
24"	42"	TSTWLR2442	\$141	TSTWHR2442	\$188
24"	48"	TSTWLR2448	\$162	TSTWHR2448	\$209
24"	54"	TSTWLR2454	\$189	TSTWHR2454	\$236
24"	60"	TSTWLR2460	\$203	TSTWHR2460	\$250
24"	66"	TSTWLR2466	\$231	TSTWHR2466	\$278
24"	72"	TSTWLR2472	\$239	TSTWHR2472	\$286
30"	60"	TSTWLR3060	\$244	TSTWHR3060	\$288
30"	66"	TSTWLR3066	\$254	TSTWHR3066	\$295
30"	72"	TSTWLR3072	\$261	TSTWHR3072	\$308



For Canadian Pricing
 Multiply U.S. Price by the Canadian price factor.
 ▶ See page 1 for details.

Worksurfaces

Tapered

Tip: Reinforcing channel (TSATRC57) is required to add support to worksurfaces that have 60" or more of unsupported kneespace.
 ▶ Page 92

Tip: Standard worksurfaces are 1 1/8" thick. However, the actual thickness between Low-Pressure Laminate (LPL) and High-Pressure Laminate (HPL) worksurfaces is slightly different. It is recommended that only worksurfaces of the same type are specified in a given application. In addition, there may be sheen or texture differences when using LPL and HPL in adjacent applications. Please use caution when mixing and matching different worksurface types.

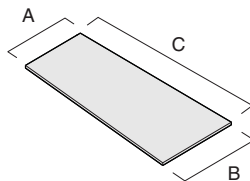
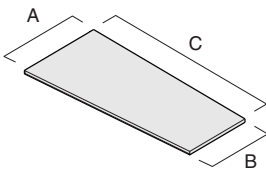

Standard Includes	Required to Specify
-------------------	---------------------

<ul style="list-style-type: none"> ▶ Need help? Product details, page 56 • 1 1/8"-thick worksurface: Low-Pressure Laminate or High-Pressure Laminate • 3 mm radius profile edge on tapered edge: plastic • 1 mm side and back edges: plastic default to match tapered edge • Shipped ready to install 	<ol style="list-style-type: none"> 1 Style number 2 Low-Pressure Laminate or High-Pressure Laminate color number for worksurface 3 Plastic edge band color number for worksurface 4 Options, if selected (see below) <p>▶ See <i>Surface Materials</i>, page 106</p>
--	--

Surface Materials	Options	U.S. Price	Required to Specify
-------------------	---------	------------	---------------------

Surface Materials	High-Pressure Laminate worksurfaces	+ \$64 plus cost of laminate	▶ See <i>Surface Materials Reference Manual</i> .
	• Open Line laminate		

Related Products	<ul style="list-style-type: none"> • Worksurface supports • Modesty panels • Reinforcing channel 	<ul style="list-style-type: none"> ▶ Page 90 ▶ Page 94 ▶ Page 92
-------------------------	---	---

Specification Information					
Dimensions	Style Number	U.S. Price	Style Number	U.S. Base Price	U.S. Price
A B C	LPL	Price	HPL	Price	Price

•	•	•	•	•	•
:	:	:	:	:	:
:	:	:	:	:	:

Left-Hand Worksurfaces

30"	24"	48"	TSTWLT3248	\$345	TSTWHT3248	\$397
30"	24"	54"	TSTWLT3254	\$368	TSTWHT3254	\$428
30"	24"	60"	TSTWLT3260	\$389	TSTWHT3260	\$458
30"	24"	66"	TSTWLT3266	\$414	TSTWHT3266	\$491
30"	24"	72"	TSTWLT3272	\$441	TSTWHT3272	\$526
:	:	:	:	:	:	:

Right-Hand Worksurfaces

24"	30"	48"	TSTWLT2348	\$345	TSTWHT2348	\$397
24"	30"	54"	TSTWLT2354	\$368	TSTWHT2354	\$428
24"	30"	60"	TSTWLT2360	\$389	TSTWHT2360	\$458
24"	30"	66"	TSTWLT2366	\$414	TSTWHT2366	\$491
24"	30"	72"	TSTWLT2372	\$441	TSTWHT2372	\$526
:	:	:	:	:	:	:



For Canadian Pricing
 Multiply U.S. Price by the Canadian price factor.
 ▶ See page 1 for details.

120° Corner Worksurfaces

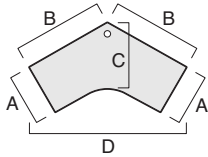
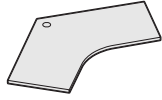

Standard Includes		Required to Specify
<ul style="list-style-type: none"> ▶ Need help? Product details, page 56 	<ul style="list-style-type: none"> • 1 1/8"–thick work surface: Low-Pressure Laminate or High-Pressure Laminate • 3 mm radius profile edge on user's side: plastic • Grommet: black plastic only • Shipped ready to install 	<ol style="list-style-type: none"> 1 Style number 2 Low-Pressure Laminate or High-Pressure Laminate color number for work surface 3 Plastic edge band color number for work surface 4 Options, if selected (see below) <p>▶ See <i>Surface Materials</i>, page 106</p>

Options	U.S. Price	Required to Specify
Surface Materials <ul style="list-style-type: none"> • High-Pressure Laminate work surfaces • Open Line laminate 	+\$64 plus cost of laminate	▶ See <i>Surface Materials Reference Manual</i> .
Related Products <ul style="list-style-type: none"> • Work surface supports • Modesty panels 		▶ Page 90 ▶ Page 94

Specification Information		
Dimensions	Style Number	U.S. Base Price
A B C D		

Low-Pressure Laminate Worksurfaces					
24"	36"	30 1/2"	63 11/32"	TSTWLY2436	\$438
24"	42"	30 1/2"	72 3/4"	TSTWLY2442	\$470
24"	48"	30 1/2"	85 5/32"	TSTWLY2448	\$518

High-Pressure Laminate Worksurfaces					
24"	36"	30 1/2"	63 11/32"	TSTWHY2436	\$485
24"	42"	30 1/2"	72 3/4"	TSTWHY2442	\$517
24"	48"	30 1/2"	85 5/32"	TSTWHY2448	\$565

120° Corner Worksurfaces

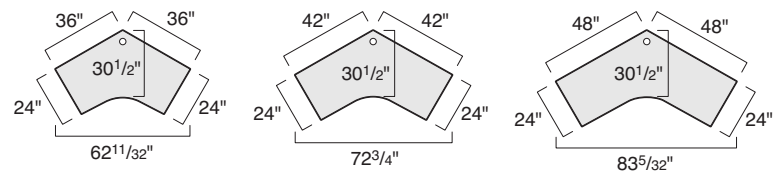

 **For Canadian Pricing**
 Multiply U.S. Price by the Canadian price factor.
 ▶ See page 1 for details.

Worksurfaces

Round

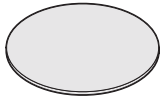

Tip: Standard worksurfaces are 1 1/8" thick. However, the actual thickness between Low-Pressure Laminate (LPL) and High-Pressure Laminate (HPL) worksurfaces is slightly different. It is recommended that only worksurfaces of the same type are specified in a given application. In addition, there may be sheen or texture differences when using LPL and HPL in adjacent applications. Please use caution when mixing and matching different work surface types.

Standard Includes		Required to Specify
<ul style="list-style-type: none"> ▶ Need help? Product details, page 56 	<ul style="list-style-type: none"> • 1 1/8"-thick work surface: Low-Pressure Laminate or High-Pressure Laminate • 3 mm radius profile edge: plastic • Shipped ready to install 	<ol style="list-style-type: none"> 1 Style number 2 Low-Pressure Laminate or High-Pressure Laminate color number for work surface 3 Plastic edge band color number for work surface 4 Options, if selected (see below) <ul style="list-style-type: none"> ▶ See <i>Surface Materials</i>, page 106

Options	U.S. Price	Required to Specify
Surface Materials <ul style="list-style-type: none"> • High-Pressure Laminate work surfaces • Open Line laminate 	<ul style="list-style-type: none"> • +\$64 plus cost of laminate 	<ul style="list-style-type: none"> ▶ See <i>Surface Materials Reference Manual</i>.
Related Products <ul style="list-style-type: none"> • Post legs • Groupwork round table bases • Floating round work surface support 		<ul style="list-style-type: none"> ▶ Page 91 ▶ Page 91 ▶ Page 92

Specification Information				
• Dimensions • Diameter	• Style • Number • LPL	• U.S. • Price	• Style • Number • HPL	• U.S. • Base • Price
30"	TSTWLDLR30	\$235	TSTWHDR30	\$270
36"	TSTWLDLR36	\$274	TSTWHDR36	\$300
:	:	:	:	:



For Canadian Pricing

Multiply U.S. Price by the Canadian price factor.

▶ See page 1 for details.

Worksurface Supports

Tip: Worksurface frame supports must have one end attached to a shelf, counter or a support on the opposite end such as a laminate worksurface frame support or post legs. Worksurface frame supports cannot support both ends of a freestanding worksurface.

	Standard Includes	Required to Specify
<ul style="list-style-type: none"> ▶ Need help? Product details, page 58 	<ul style="list-style-type: none"> • Worksurface frame supports: paint price group 1 • Post legs: paint • Table bases: paint • Laminate worksurface frame support: Low-Pressure Laminate with matching plastic edge band • Tapered leg: paint • Tie plates: black only • Floating round worksurface support: black only • Leveling glides • Attachment hardware • Shipped ready to install 	<ol style="list-style-type: none"> 1 Style number 2 Paint color number for worksurface frame supports, post legs, tapered legs, and tables bases 3 Low-Pressure Laminate color number for worksurface frame supports 4 Options, if selected (see below) <p>▶ See <i>Surface Materials</i>, page 106.</p>

	Options	U.S. Price	Required to Specify
Surface Materials	Worksurface frame supports		
	• Paint price group 1	No cost	Specify paint color number.
	• Paint price group 2	+\$27	Specify paint color number.
	Post legs		
	• Paint price group 1	No cost	Specify paint color number.
	• Paint price group 2	+\$10 per leg	Specify paint color number.
	Table bases		
	• Paint price group 1	No cost	Specify paint color number.
	• Paint price group 2	+\$27	Specify paint color number.
Casters	One post or standing-height table leg		
	• One locking caster	+\$ 5	Specify <i>with caster</i> .
Pin Height-Adjustable Legs	• One post leg	+\$47	Specify <i>with pin height-adjustable leg</i> .
Related Products	<ul style="list-style-type: none"> • Worksurfaces • Shelves • My file 		<ul style="list-style-type: none"> ▶ Page 85 ▶ Page 93 ▶ Page 100

Specification Information			
Dimensions	Style	U.S.	
D H	Number	Base Price	

Worksurface Frame Supports			
18"	15"	TSTTF1518	\$166
24"	27"	TSTTF2724	\$270
30"	27"	TSTTF2730	\$291

Laminate Worksurface Supports			
24"	27"	TSTTL2724	\$270
30"	27"	TSTTL2730	\$291

▶ **Specification Information, continued on next page**

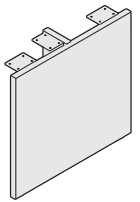
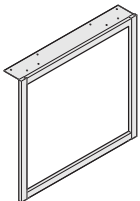

► Specification Information, continued from previous page

Specification Information

• Dimensions		• Style	• U.S.
H	Dia	Number	Base Price

One Post Leg

27 ³ / ₈ "		TS4L27PG	\$ 97
----------------------------------	--	-----------------	-------

One Standing-Height Adjustable Post Leg

27 ³ / ₈ "–44"		TS4LSHPG	\$172
--------------------------------------	--	-----------------	-------

Tapered Leg

27 ³ / ₈ "		TSTT27M	\$125
----------------------------------	--	----------------	-------

Package of Four Tapered Legs

27 ³ / ₈ "		TSTT27M4	\$441
----------------------------------	--	-----------------	-------

Adjustable Round Table Base

27 ³ / ₈ "	18"	TSTTT27	\$349
----------------------------------	-----	----------------	-------

Café-Height Adjustable Round Table Base

41"	18"	TSTTT39	\$371
-----	-----	----------------	-------

► Specification Information, continued on next page

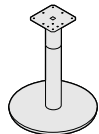
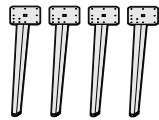
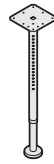
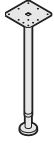

Tip: Adjustability range is 3¹/₂".
 Tip: Tour adjustable round table bases are not approved for freestanding applications. Round table bases are intended to be used at one end of a worksurface that is attached to a Tour counter. For freestanding applications see Groupwork round table bases in the Turnstone 1.0 Specification Guide.

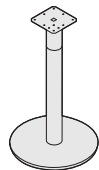

Tour Workspace

Worksurface Support, continued

► Specification Information, continued from previous page

Specification Information

• Dimensions		• Style	• U.S.
H	Dia	Number	Base Price

Pair of Counter-to-Worksurface Tie Plates

	TSTTPC2W	\$ 94
--	-----------------	-------



Tip: Two sets of tie plates are required if worksurface is attached parallel to the counter.

Pair of Shelf-to-Worksurface Tie Plates

	TSTTPS2W	\$ 38
--	-----------------	-------



Tip: Two sets of tie plates are required if worksurface is attached parallel to the shelf.

Counter Frame-to-Worksurface Tie Plate

	TSTTPF2W	\$ 88
--	-----------------	-------

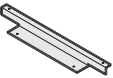

Floating Round Worksurface Support

	TSTTTZD	\$ 52
--	----------------	-------



Reinforcing Channels

39"W	TSATRC39	\$ 42
57"W	TSATRC57	\$ 45
72"W	TSATRC72	\$103

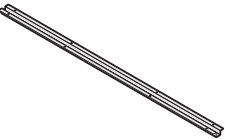

Flip Grommet

Standard Includes	Required to Specify
<ul style="list-style-type: none"> • Flip cover: paint • Bottom grommet portion: black plastic 	<ul style="list-style-type: none"> 1 Style number 2 Paint color number for flip cover ► See <i>Surface Materials</i>, page 106.

Specification Information

• Dimensions			• Style	• U.S.
D	W	H	Number	Price

4 ¹ / ₂ "	4"	1 ³ / ₄ "	TS5GF3	\$55
---------------------------------	----	---------------------------------	---------------	------

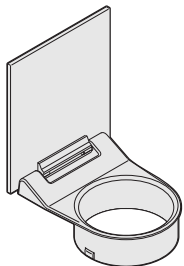

Tip: Flip grommet requires a 3" diameter hole in the worksurface.

Shelves

Tip: Standard worksurfaces are 1 1/8" thick. However, the actual thickness between Low-Pressure Laminate (LPL) and High-Pressure Laminate (HPL) worksurfaces is slightly different. It is recommended that only worksurfaces of the same type are specified in a given application. In addition, there may be sheen or texture differences when using LPL and HPL in adjacent applications. Please use caution when mixing and matching different worksurface types.

Standard Includes		Required to Specify
<ul style="list-style-type: none"> ▶ Need help? Product details, page 56 	<ul style="list-style-type: none"> • 1 1/8"-thick shelf: Low-Pressure Laminate or High-Pressure Laminate • 3 mm radius profile edge: plastic • Shelf-to-counter attachment hardware: 4799 Platinum • Cutout for vertical cord cover • Shipped ready to install 	<ol style="list-style-type: none"> 1 Style number 2 Low-Pressure Laminate or High-Pressure Laminate color number for shelf 3 Plastic edge band color number for shelf 4 Options, if selected (see below) <p>▶ See <i>Surface Materials</i>, page 106.</p>

Options	U.S. Price	Required to Specify
Surface Materials • High-Pressure Laminate worksurfaces • Open Line laminate	+\$64 plus cost of laminate	▶ See <i>Surface Materials Reference Manual</i> .
Related Products • Counters • Post legs		▶ Page 68 ▶ Page 91

Specification Information					
Dimensions		Style Number	U.S. Price	Style Number	U.S. Base Price
D	W	LPL		HPL	

Shelves

9"	70"	TSTMLF0970	\$187	TSTMHF0970	\$234
21"	70"	TSTMLF2170	\$275	TSTMHF2170	\$322
33"	70"	TSTMLF3370	\$320	TSTMHF3370	\$367
:	:	:	:	:	:

Corner Shelves

Left-Hand Corner Shelves					
45"	70"	TSTMLF4570L	\$281	TSTMHF4570L	\$328
Right-Hand Corner Shelves					
45"	70"	TSTMLF4570R	\$281	TSTMHF4570R	\$328
:	:	:	:	:	:

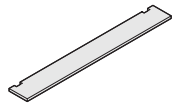

Right-hand corner shelf shown

Tip: Corner shelf requires one post leg for support.

Tip: 21"D and 33"D rectangular shelves and corner shelves require additional support of a post leg or end support.

▶ See page 58

For Canadian Pricing
 Multiply U.S. Price by the Canadian price factor.
 ▶ See page 1 for details.

Modesty Panels

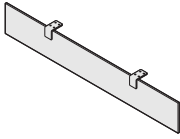

Tip: Modesty panel is 6" shorter from each side of worksurface.

Standard Includes	Required to Specify
<ul style="list-style-type: none"> • Modesty panel: Low-Pressure Laminate with matching polypropylene edge band • Brackets: paint price group 1 • Attachment hardware: black • Shipped ready to install 	<ol style="list-style-type: none"> 1 Style number 2 Low-Pressure Laminate color number for modesty panel 3 Paint color number for brackets 4 Options, if selected (see below) <p>▶ See <i>Surface Materials</i>, page 106.</p>

Options	U.S. Price	Required to Specify
Surface Materials <ul style="list-style-type: none"> • Paint price group 1 • Paint price group 2 	No cost +\$16	Specify paint color number. Specify paint color number.

Specification Information				
• Dimensions		• Corresponding Table Top Width	• Style Number	• U.S. Base Price
W	H			
30"	12"	42"	TSTWMP1242	\$189
36"	12"	48"	TSTWMP1248	\$202
42"	12"	54"	TSTWMP1254	\$215
48"	12"	60"	TSTWMP1260	\$227
54"	12"	66"	TSTWMP1266	\$239
60"	12"	72"	TSTWMP1272	\$253
:	:	:	:	:



For Canadian Pricing
 Multiply U.S. Price by the Canadian price factor.
 ▶ See page 1 for details.

Screens

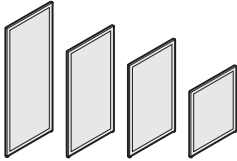

Tip: Screens attach easily to counters.

Standard Includes	Required to Specify
<ul style="list-style-type: none"> ▶ Need help? Product details, page 60 • Frame: Clear Anodized Aluminum • Infill: Low-Pressure Laminate • Adjustable leveling glides • Shipped ready to install 	<ul style="list-style-type: none"> 1 Style number 2 Low-Pressure Laminate color number for screens ▶ See <i>Surface Materials</i>, page 106.

Related Products
<ul style="list-style-type: none"> • Screen connectors • Counters

Specification Information				
• Dimensions			• Style	• U.S.
D	W	H	Number	Price

Screens

1"	24"	30"	TSTPL3024	\$224
1"	30"	30"	TSTPL3030	\$240
1"	36"	30"	TSTPL3036	\$286
1"	42"	30"	TSTPL3042	\$292
1"	48"	30"	TSTPL3048	\$304
1"	24"	42"	TSTPL4224	\$269
1"	30"	42"	TSTPL4230	\$292
1"	36"	42"	TSTPL4236	\$349
1"	42"	42"	TSTPL4242	\$361
1"	48"	42"	TSTPL4248	\$384
1"	24"	48"	TSTPL4824	\$292
1"	30"	48"	TSTPL4830	\$304
1"	36"	48"	TSTPL4836	\$361
1"	42"	48"	TSTPL4842	\$384
1"	48"	48"	TSTPL4848	\$407
1"	24"	60"	TSTPL6024	\$309
1"	30"	60"	TSTPL6030	\$361
1"	36"	60"	TSTPL6036	\$384
1"	42"	60"	TSTPL6042	\$458
1"	48"	60"	TSTPL6048	\$498
.

 **For Canadian Pricing**
 Multiply U.S. Price by the Canadian price factor.
 ▶ See page 1 for details.

Screens Connectors

Standard Includes	Required to Specify
<ul style="list-style-type: none"> Need help? Product details, page 60 Screen connectors: 4799 Platinum paint 	<ul style="list-style-type: none"> Style number

Related Products
<ul style="list-style-type: none"> Screens Worksurfaces

Specification Information

Style Number	U.S. Price

Inline and L, Same Height Screen Connector

TSTPBSH2	\$29

T, Same Height Screen Connector

TSTPBSH3	\$42

Inline and L, Change-of-Height Screen Connectors

TSTPBCOH2	\$29

T, Change-of-Height Screen Connectors

TSTPBCOH3	\$42

120° Two-Way, Same Height Screen Connector

TSTPB120	\$42

120° Three-Way, Same Height Screen Connector

TSTPB120Y	\$47

Worksurface-to-Screen Tie

TSTPBWT	\$52

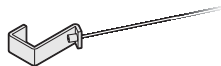
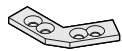
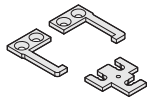
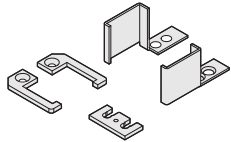
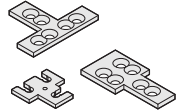
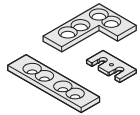

 **For Canadian Pricing**
 Multiply U.S. Price by the Canadian price factor.
 ▶ See page 1 for details.

HV Cabinet

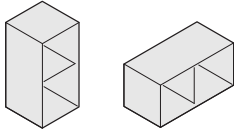

Tip: Laminate grain direction on doors runs vertical when cabinet is horizontal.

Tip: Pull paint color number is required when door option is selected.
 ▶ Page 106

Standard Includes		Required to Specify
-------------------	--	---------------------

▶ Need help? Product details, page 64	<ul style="list-style-type: none"> Steel cabinet and shelf: paint price group 1 Center divider: laminate color to complement cabinet Shipped fully assembled 	1 Style number 2 Paint color number for cabinet and shelf 3 Options, if selected (see below) ▶ See <i>Surface Materials</i> , page 106.
---	---	--

Options	U.S. Price	Required to Specify
---------	------------	---------------------

Surface Materials	Steel cabinet and shelf		
	<ul style="list-style-type: none"> Paint price group 1 Paint price group 2 	No cost +\$41	Specify paint color number. Specify paint color number.
	Pulls		
	<ul style="list-style-type: none"> Paint price group 1 Paint price group 2 	No cost +\$ 5 (per door)	Specify paint color number. Specify paint color number.
Doors	Laminate		
	<ul style="list-style-type: none"> One laminate sliding door Two laminate sliding doors 	+\$31 +\$62	Specify <i>with one laminate sliding door</i> . Specify <i>with two laminate sliding doors</i> .
Related Products	<ul style="list-style-type: none"> Counters Pile files Markerboards 		▶ Page 68 ▶ Page 102 ▶ Page 103

Specification Information

Dimensions			Style Number	U.S. Base Price
D	W	H		
18"	18"	36"	TSTSCHV36	\$395

Tour Workspace

 **For Canadian Pricing**
 Multiply U.S. Price by the Canadian price factor.
 ▶ See page 1 for details.

Shared HV Cabinet

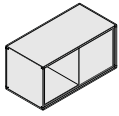

Tip: Pull paint color number is required when door option is selected.
 ▶ Page 106

Standard Includes		Required to Specify
▶ Need help? Product details, page 64	<ul style="list-style-type: none"> Steel cabinet and center divider: paint price group 1 Non-locking Shipped fully assembled 	1 Style number 2 Paint color number for cabinet and center divider 3 Options, If selected (see below) ▶ See <i>Surface Materials</i> , page 106.

	Options	U.S. Price	Required to Specify
Surface Materials	Steel cabinet		
	<ul style="list-style-type: none"> Paint price group 1 Paint price group 2 	No cost +\$ 41	Specify paint color number. Specify paint color number.
	Pulls		
	<ul style="list-style-type: none"> Paint price group 1 Paint price group 2 	No cost +\$ 10	Specify paint color number. Specify paint color number.
Doors	Laminate		
	<ul style="list-style-type: none"> Two laminate sliding doors 	+\$ 62	Specify with two laminate sliding doors and indicate laminate color number. ▶ See <i>Surface Materials</i> , page 106.
Related Products	<ul style="list-style-type: none"> Magnetic markerboards Magnetic tackboards 		▶ Page 103 ▶ Page 103

Specification Information				
Dimensions			Style Number	U.S. Base Price
D	W	H		
18"	18"	36"	TTSCHVD36	\$562



For Canadian Pricing
 Multiply U.S. Price by the Canadian price factor.
 ▶ See page 1 for details.

Bookcases

Standard Includes		Required to Specify
▶ Need help? Product details, page 65	<ul style="list-style-type: none"> • Low-Pressure Laminate bookcase with matching polypropylene edge band • Two fixed shelves each side for shared bookcase • One fixed shelf for personal bookcase • Shipped fully assembled 	1 Style number 2 Low-Pressure Laminate color number for bookcase 3 Options, if selected (see below) ▶ See <i>Surface Materials</i> , page 106.

Options	U.S. Price	Required to Specify
Legs	• Legs for personal bookcase +\$52	Specify <i>with legs</i> .
Related Products	• Counters • Pile files	▶ Page 68 ▶ Page 102

Tip: A personal bookcase can be specified with optional legs for use at the bottom of a counter.

Specification Information

Dimensions			Style Number	U.S. Base Price
D	W	H		

Shared Bookcase

18"	18"	36"	TSTSBS3618	\$603
-----	-----	-----	-------------------	-------

Personal Bookcase

9"	18"	18"	TTSBP1818	\$296
----	-----	-----	------------------	-------

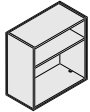
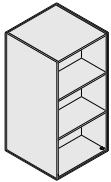

without legs (standard)

with legs (optional)

 **For Canadian Pricing**
 Multiply U.S. Price by the Canadian price factor.
 ▶ See page 1 for details.

My File

Standard Includes		Required to Specify
<ul style="list-style-type: none"> ▶ Need help? Product details, page 66 	<ul style="list-style-type: none"> • My file and drawer front: Low-Pressure Laminate • Steel drawer body: black only • File drawer to accommodate suspended side-to-side filing, and provides space in front of files for miscellaneous storage • Non-locking drawer • Turnstone ledge pull: paint price group 1 • Adjustable leveling glides • Shipped fully assembled • Attachment hardware 	<ol style="list-style-type: none"> 1 Style number 2 Low-Pressure Laminate color number for file and drawer front 3 Paint color number for Turnstone ledge pull 4 Options, if selected (see below) <ul style="list-style-type: none"> ▶ See <i>Surface Materials</i>, page 106. <i>Tip: Remember to specify lock cylinder and key.</i> <ul style="list-style-type: none"> ▶ Lock cylinders, page 265

Options	U.S. Price	Required to Specify
Surface Materials Pulls <ul style="list-style-type: none"> • Paint price group 1 • Paint price group 2 	No cost +\$ 6	Specify paint color number. Specify paint color number.
Drawer lock <ul style="list-style-type: none"> • Drawer lock: 9201 Polished Chrome 	+\$107	Specify with <i>9201 Polished Chrome lock</i> .
Related Products <ul style="list-style-type: none"> • Worksurfaces 		▶ Page 85

Tip: Remember to specify lock cylinder and key.
 ▶ Lock cylinders, page 265

Specification Information

Dimensions			Style Number	U.S. Base Price
D	W	H		
24"	18"	15"	TSTSFL1518	\$624
24"	36"	15"	TSTSFL1536	\$988

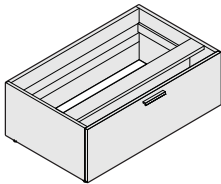
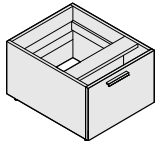

 **For Canadian Pricing**
 Multiply U.S. Price by the Canadian price factor.
 ▶ See page 1 for details.

Lateral File Cushion

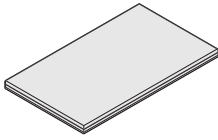

Tip: Lateral file cushion can be installed on Tour coffee table height work-surface when attached to a Tour counter and above a my file on worksurface frame support.

Standard Includes	Required to Specify
<ul style="list-style-type: none"> Fully upholstered lateral file cushion: fabric price group 1 Hardware package to attach cushion to worksurface Meets Cal. 116 and 117 requirements Ships ready to assemble 	<ol style="list-style-type: none"> Style number Fabric color number for lateral file cushion Options, if selected (see below) <p>▶ See <i>Surface Materials</i>, page 196.</p>

		Options	U.S. Price	Required to Specify
Surface Materials	Upholstery	• Fabric price group 1	No cost	Specify fabric color number.
		• Fabric price group 2	+\$ 22	Specify fabric color number.
		• Fabric price group 3	+\$ 43	Specify fabric color number.
		• Fabric price group 4	+\$ 59	Specify fabric color number.
		• Fabric price group 5	+\$ 75	Specify fabric color number.
		• Fabric price group 6	+\$ 92	Specify fabric color number.
		• Fabric price group 7	+\$107	Specify fabric color number.
		• Fabric price group 8	+\$134	Specify fabric color number.
		• Fabric price group 9	+\$166	Specify fabric color number.
		• Fabric price group 10	+\$187	Specify fabric color number.
		• Leather price group	+\$468	Specify fabric color number.
		• Customer's Own Material (COM)	+\$ 32	Add suffix L to style number and specify leather color number.
				▶ See <i>Understanding Customer's Own Material (COM)</i> , page 260

Specification Information				
• Dimensions			• Style	• U.S.
D	W	H	Number	Base Price
24"	36"	2"	TSTLATPAD	\$263
:	:	:	:	:
:	:	:	:	:

For Canadian Pricing
 Multiply U.S. Price by the Canadian price factor.
 ▶ See page 1 for details.

Pile File



Tip: Adding a markerboard increases the usability of the pile file's steel top and back.

Tip: Add an HV cabinet or bookcase to the top to add more storage space.

Tip: For legal size front-to-back filing, use 15" universal storage rail RXADRL15.

Tip: Remember to specify lock cylinder and key.

▶ Lock cylinders, page 265

Standard Includes	Required to Specify
<p>▶ Need help? Product details, page 67</p> <ul style="list-style-type: none"> • Steel top, back, and fixed center shelf: paint price group 1 • Drawer front, sides and sliding shelves: Low-Pressure Laminate • Drawer body: black only • Drawer and shelf suspensions: black only • Turnstone ledge pull: paint price group 1 • Adjustable leveling glides • Shipped fully assembled 	<ol style="list-style-type: none"> 1 Style number 2 Paint color number for top, back, and fixed center shelf 3 Low-Pressure Laminate color number for drawer front, sides, and sliding shelves 4 Paint color number for Turnstone ledge pull 5 Options, if selected (see below) <p>▶ See <i>Surface Materials</i>, page 106.</p>

Options	U.S. Price	Required to Specify
<p>Surface Materials</p> <p>Steel top, back, and fixed center shelf</p> <ul style="list-style-type: none"> • Paint price group 1 • Paint price group 2 <hr/> <p>Pulls</p> <ul style="list-style-type: none"> • Paint price group 1 • Paint price group 2 	<p>No cost</p> <p>+\$ 41</p> <hr/> <p>No cost</p> <p>+\$ 6</p>	<p>Specify paint color number.</p> <p>Specify paint color number.</p> <hr/> <p>Specify paint color number.</p> <p>Specify paint color number.</p>
<p>Drawer lock</p> <ul style="list-style-type: none"> • Drawer lock: 9201 Polished Chrome 	<p>+\$107</p>	<p>Specify <i>with 9201 Polished Chrome lock.</i></p>
<p>Casters</p> <ul style="list-style-type: none"> • Casters 	<p>+\$ 52</p>	<p>Specify <i>with casters.</i></p>
<p>Related Products</p> <ul style="list-style-type: none"> • Markerboards • HV cabinets 		<p>▶ Page 103</p> <p>▶ Page 97</p>

Specification Information				
• Dimensions			• Style	• U.S.
D	W	H	Number	Base Price
18"	36"	42"	TSTSFP4236	\$1092
.



For Canadian Pricing

Multiply U.S. Price by the Canadian price factor.

▶ See page 1 for details.

Markerboards

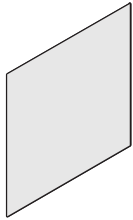

Tip: Makes a convenient markerboard on any steel surfaces.

Standard Includes	Required to Specify
<ul style="list-style-type: none"> ▶ Need help? Product details, page 64 • Magnetic markerboard: 6650 Sodium 	Style number

Related Products
<ul style="list-style-type: none"> • HV cabinets • Pile files

▶ Page 97
▶ Page 102

Specification Information				
• Dimensions			• Style	• U.S.
D	W	H	Number	Price
1/8"	18"	18"	TSTSMB1818	\$ 52
1/8"	36"	18"	TSTSMB3618	\$104

Tour Workspace

Tackboards

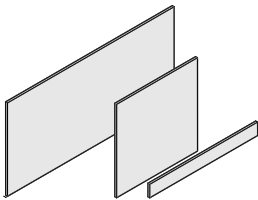

Standard Includes	Required to Specify
<ul style="list-style-type: none"> ▶ Need help? Product details, page 64 • Magnetic tackboard: fabric price group A (Systems upholstery) 	1 Style number 2 Fabric color number for upholstery 3 Options, if selected (see below) ▶ See <i>Surface Materials</i> , page 106.

Options	U.S. Price	Required to Specify
Surface Materials		
Standard Systems Upholstery		
• Fabric price group A	No cost	Specify fabric color number.
• Fabric price group 1	+\$ 5	Specify fabric color number.
Standard Seating Upholstery		
• Fabric price group 1	+\$ 5	Specify fabric color number.
• Fabric price group 2	+\$14	Specify fabric color number.
• Fabric price group 3	+\$22	Specify fabric color number.
Designtex Seating Upholstery		
• Fabric price group 2	+\$14	Specify fabric color number.
• Fabric price group 3	+\$22	Specify fabric color number.
• Customer's Own Material (COM)	+\$32	Specify fabric color number. ▶ See <i>Understanding Customer's Own Material (COM)</i> , page 260

Specification Information			
• Dimensions		• Style	• U.S.
W	H	Number	Base Price
22"	21/2"	TSTSMT0322	\$ 99
18"	18"	TSTSMT1818	\$187
36"	18"	TSTSMT3618	\$291

For Canadian Pricing
Multiply U.S. Price by the Canadian price factor.
▶ See page 1 for details.

Task Lights

Underline Task Light

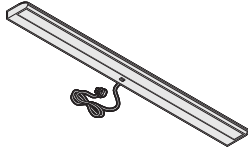

	Standard Includes	Required to Specify
<p>▶ Need help? See <i>Details</i> <i>SpecGuide</i> for product details.</p>	<ul style="list-style-type: none"> • Steel light housing: paint • Aluminum reflector • Acrylic lens • Polycarbonate end caps: molded to match housing • Cords, 9' cord with three-prong plug at 90°/45° angle: black plastic only • Soft touch switch • Thin profile, energy-efficient T2 fluorescent lamp • Universal spring brackets for recessed mount and screw-in for flush mount • Tool free clips for New York application 	<ul style="list-style-type: none"> 1 Style number 2 Paint color number for housing and end caps: <ul style="list-style-type: none"> 0835 Black 7018 Pewter 7021 Dark Champagne

Specification Information

• Dimensions			• Lamp	• Style	• U.S.
D	W	H	Wattage	Number	Price
Without Dimming					
4¾"	22"	¾"	13 watts	LT2	\$257
With Chicago Cord Including Circuit Breaker					
4¾"	22"	¾"	13 watts	LT2CHI	\$296

Mini LED Task Light



	Standard Includes	Required to Specify
<p>▶ Need help? See <i>Details</i> <i>SpecGuide</i> for product details.</p>	<ul style="list-style-type: none"> • Light: 4799 Platinum • 9' power cord • Attachment hardware 	<ul style="list-style-type: none"> Style number

Specification Information

• Dimensions			• Style	• U.S.
D	W	H	Number	Price
1½"	7"	¾"	LMINILED	\$229

 **For Canadian Pricing**
Multiply U.S. Price by the Canadian price factor.
▶ See page 1 for details.

SOTO

Tour Rails

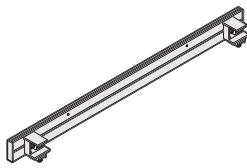

Tip: Allow 1" clearance between worksurface and rail for cable management. Allow 2" for rail mount installed behind a worksurface, and 3¾" overall to install the rail.

Tip: Maximum weight load rails are 2 lbs per linked inch.

Tip: Each clamp requires a 2" footprint above the worksurface, and a 3¼" clearance below the worksurface.

Tip: Tour rails clamp to Tour bench troughs. Rails are not applicable for glass surfaces.

Standard Includes

- Rail: 4799 Platinum

Required to Specify

Style number

Related Products

- SOTO shelves
- SOTO Worktools

- ▶ Page 228
- ▶ Page 233

Specification Information

• Corresponding Table Top Width	• Dimensions			• Style Number	• U.S. Price
	D	W	H		
60"	1"	52"	3¼"	DSRT52	\$218
66"	1"	58"	3¼"	DSRT58	\$230
72"	1"	64"	3¼"	DSRT64	\$240
:	:	:	:	:	:

Tour Workspace

Products on this page are Details, not Turnstone.

They are included here to simplify your planning. Remember that Details has different pricing terms than Turnstone products.



For Canadian Pricing

Multiply U.S. Price by the Canadian price factor.
▶ See page 1 for details.

Surface Materials

► For Surface Materials matrices for all product lines, see page 241.

Laminate

Steelcase Surfaces

Low-Pressure Laminate

Applies to:

- Counter center infill and end panel infill
- Laminate worksurface supports
- Countertops
- Worksurfaces
- Shelves
- Modesty panels
- Screens
- HV cabinet doors
- Bookcases
- Pile files
- My file

- 25L1 Winter on Maple LPL
- 25L5 Virginia Walnut LPL*
- 25L6 Blackwood LPL*
- 25L8 Clear Walnut LPL*
- 25L9 Warm Oak LPL*
- 26L1 Natural Cherry Version 2 LPL
- 2L30 Arctic White LPL

*For these new finishes call 1.800.TURNSTONE for availability.

High-Pressure Laminate

Applies to: (standard products)

- Worksurfaces
- Shelves

- 2412 Natural Cherry Version 2 HPL
- 2511 Winter on Maple HPL
- 2535 Virginia Walnut HPL*
- 2536 Blackwood HPL*
- 2538 Clear Walnut HPL*
- 2539 Warm Oak HPL*
- 2730 Arctic White HPL

*For these new finishes call 1.800.TURNSTONE for availability.

Custom Surfaces

Open Line Laminate (OLL)

This service allows you to order non-standard laminate at an additional processing fee of \$64 U.S. per worksurface or top, plus the cost of the laminate.

When processing orders for Open Line laminate on Turnstone products, specify 2900 in the laminate finish field and enter the OLL manufacturer information. Enter the required edge finish as you would a standard laminate.

Edge color for the Open Line laminate on Turnstone products must be determined by the dealer and customer before orders can be entered. Specify appropriate 2K finish number. *Tip: Standard laminates being used in the Open Line Laminate program to obtain a different edge detail will be charged the Open Line laminate upcharge; however, no additional charges for the laminate will be applied.*

Laminate Approval and Material Requirements

To confirm whether a particular laminate has already been tested for use on a specific Steelcase product or to determine material square foot requirements:

- Visit www.steelcase.com

For additional information, refer to the *Steelcase Surface Materials Reference Manual*.

Plastic

Steelcase Surfaces

Applies to:

- Worksurface edge band
- Shelf edge band

- 6000 Black*
- 6009 Arctic White*
- 6034 Natural Cherry
- 6037 Winter On Maple
- 6053 Seagull*
- 6242 Virginia Walnut*
- 6243 Blackwood*
- 6245 Clear Walnut*
- 6246 Warm Oak*
- 6636 Mist*
- 6654 Sand*
- 6655 Warm White*
- 6676 Marbled Maple
- 6677 Chocolate Walnut
- 6678 Marbled Cherry
- 6689 Brushed Silver*

*These solid color and wood grain edge colors are a polyolefin blend, PVC-free material for 3 mm and 1 mm edge bandings.

Applies to:

- Vertical cord cover grommet insert

- 6000 Black
- 6009 Arctic White
- 6249 Platinum Solid

Paint

Steelcase Surfaces

Applies to:

- Counter top tray
- Counter center infill
- HV and shared HV cabinets
- Vertical cord cover
- Pile file top, back, and fixed center shelf
- Bench trough
- Bench screen
- Post legs
- Worksurface frame support
- Modesty panel bracket

Price Group 1

- 7207 Black (Textured)
- 7225 Sand (Textured)
- 7241 Arctic White (Textured)
- 7243 Seagull (Textured)

Price Group 2

- 4750 Champagne Metallic
- 4798 Sterling Metallic
- 4799 Platinum Metallic
- 7246 Midnight Metallic (Textured)

Applies to:

- HV cabinet laminate sliding door pulls
- Pile file Turnstone ledge pulls
- My file Turnstone ledge pull

Price Group 1

- 7207 Black (Textured)

Price Group 2

- 4799 Platinum Metallic

HV Cabinet Center Divider

Steelcase Surfaces

HV cabinet center divider laminate color number defaults based on the paint selection.

Cabinet paint:	Default laminate center divider:
4750 Champagne Metallic	2L85 Dune
4798 Sterling Metallic	247L Black
4799 Platinum Metallic	247L Black
7207 Black (Textured)	247L Black
7225 Sand (Textured)	2L85 Dune
7241 Arctic White (Textured)	2L30 Arctic White
7243 Seagull (Textured)	2L83 Seagull
7246 Midnight Metallic (Textured)	247L Black

Upholstery

Steelcase Surfaces

Applies to:

- Magnetic tackboards

Systems Upholstery

Price Group A

Braccia **E**

Price Group 1

Boccie

Seating Upholstery

Price Group 1

Buzz2

Price Group 2

Nightlights

Price Group 3

Hampstead

Turnstone Designtex Seating Upholstery

Price Group 3

Boyne
Great Lakes

E = Established

Campfire



Statement of Line 108



Product Details

Big Table Facts	110
LED Personal Task Lights	112
Mobile Storage Cabinets Facts	114
Big Lounge, Screen, and Big Lamp Facts	115
Half Lounge and Wedge Facts	116
Personal Table and Paper Table Facts	117



Specifying

Big Tables	118
Big Tables with Trough	119
Table Accessories	120
Mobile Storage Cabinets	121
Big Lamp	122
Personal Table	123
LED Personal Task Lights	124
Paper Table and Accessories	125
Screens	127
Big Lounge	128
Half Lounge and Wedge	130
Accessories	132



Surface Materials 133

Statement of Line

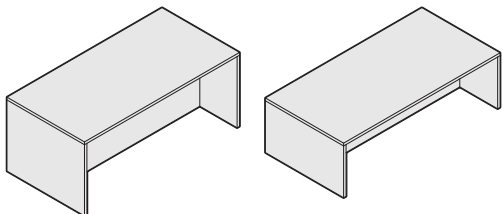

Big Tables
▶ Page 118

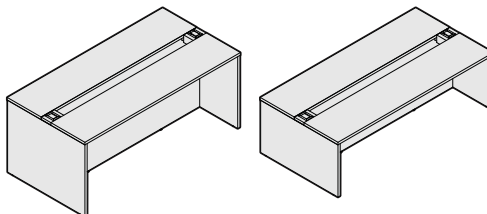

Big Tables with Trough
▶ Page 119

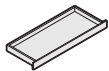
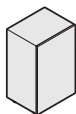

Table Drawer
▶ Page 120



Center Rail
▶ Page 120



Mobile Storage Cabinets
▶ Page 121

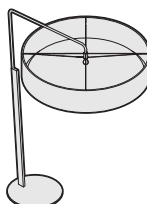

Big Lamp
▶ Page 122



Personal Table
▶ Page 123



Paper Table
▶ Page 125

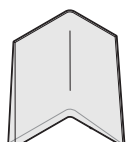

Screens
▶ Page 127

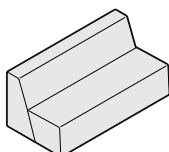

Big Lounge
▶ Page 128

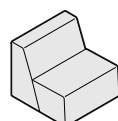

Half Lounge
▶ Page 130

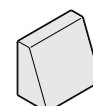

Wedge
▶ Page 131

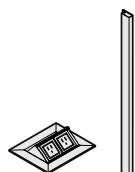

Accessories
▶ Page 132

Personal task lights

offer end users added control and adjustability to place the proper amount of personal lighting to create a holistic worksetting. Ideally suited for rail-mount, desk, or freestanding applications.

LED Lights

Rail-Mounted and Non Rail-Mounted

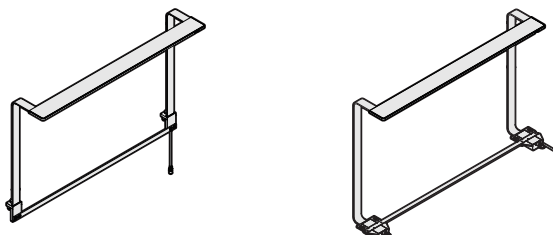
LED Personal Task Lights**Mounting**

- Rail-mounted attaches directly to rail systems in c:scape, FrameOne, Elective Elements 6, Impact, Turnstone Campfire Big Table, and Details SOTO Rail. The non rail-mounted version attaches to most freestanding desks and tables.

Tip: Non rail-mounted LED personal task lights will not work on worksurfaces with knife edge that is longer than 1/4", or with modesty panels or modesty screens closer than 6" from the back edge.

Understanding

▶ Page 112

Specifying

▶ Page 124

Depth

6"

Width

30"

Description

Intended to be a primary light source, LED personal task light covers the user's active work zone with a smartly-designed array of light. The light is specifically designed to direct light where it is needed. Energy efficient at only 14 watts, LED personal task light is engineered to have a useful life of over 50,000 hours. It attaches directly to the rail systems of c:scape, FrameOne, Impact, Elective Elements 6, Turnstone Big Table, and Details SOTO Rail. A non-rail-mounted version attaches to freestanding desks and tables.

Finish Options

- Fixture and stanchions, paint: 4710 Low Gloss Black, 4799 Platinum Metallic, and 4231 Arctic White. Plastic cover Arctic White (6009) only.

Ballasts

- Energy saving low-voltage power supply

Electronic Dimmer

- Standard on all lights

Lens Options

- Polycarbonate matte film

Average Rated Lamp Life

- 50,000 hrs.

Warranty

- Power supply - 5 years
- Fixture - 12 years

Big Table Facts

Big Tables are offered in Low-Pressure Laminate. Table tops and end panels are 1 $\frac{3}{8}$ " thick and center panel is 1" thick. Table top comes standard with two reinforcing channels built into the worksurface for added strength.

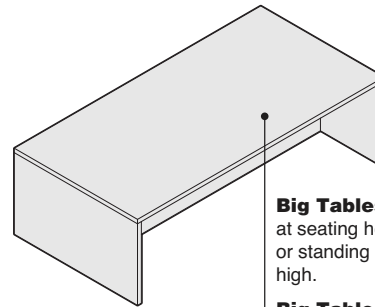
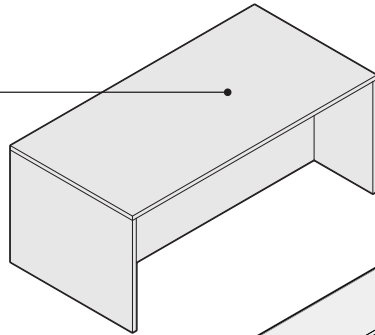

Big Tables are available at seating height of 28" high or standing height of 40" high.

Big Tables are available with an uninterrupted worksurface or Big Tables can be specified with a split worksurface top with a trough that runs down the center of the table.

Dual anodized aluminum power and data solutions are available as a standard option or field installed. 15-amp, one-circuit power solution with 10' cord.

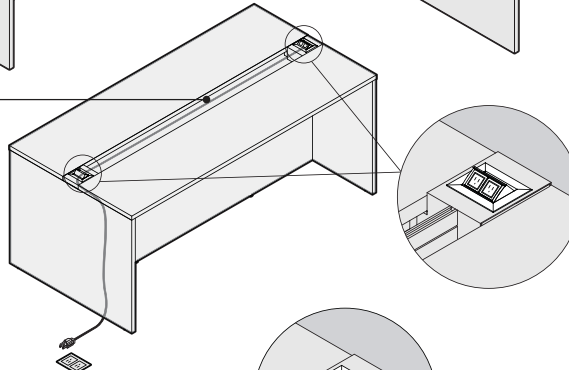

TS4TPWR and TS4TPWRD requires one (1) building outlet and provides four (4) user outlets. When ordering data TS4TPWRD, user will get one (1) outlet and one (1) data opening on each end.

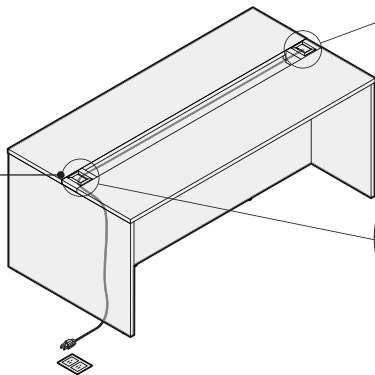

Flip grommets come standard on each end of Big Table with trough when power is not optioned.

Single anodized aluminum power and data solutions are also available for field installation. They replace one of the standard grommets. 15-amp, one-circuit power solution with a 10' cord is standard.

TS4TPWR1 and TS4TPWRD1 provide a lower cost solution that requires one (1) building outlet and provides two (2) user outlets. When ordering data TS4TPWRD1, user will get one (1) outlet and one (1) data opening.

When using two (2) single anodized power and data solutions, a second building outlet is required.

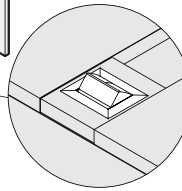

Big Table trough has a 10" depth, with 6" open inside the split worksurface and 2" on each side underneath the Big Table worksurface.

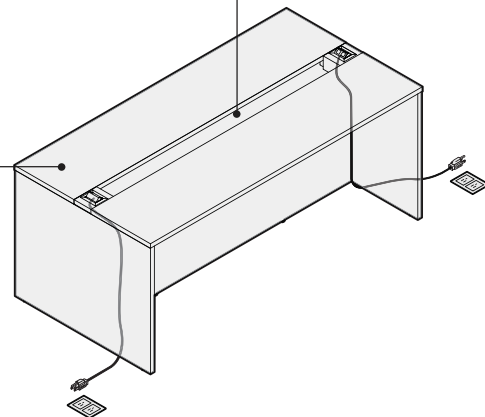

Actual Dimensions

Depth	48"
Width	96"
Height	28" or 40"

Product Details

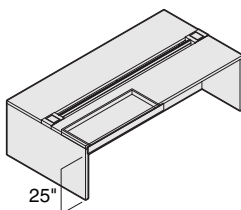
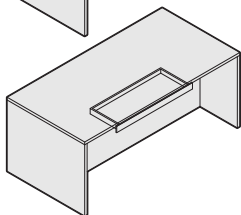
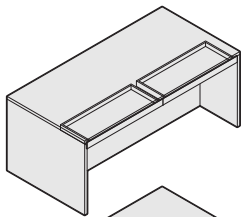

Low-Pressure Laminate table drawer

is 3"D x 48"W, can be placed in three locations on either side of the Big Table and Big Table with Trough. *Tip: When used on a 28"H Big Table knee clearance will be reduced by 3".*

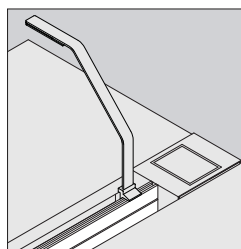

Optional anodized aluminum table rail installs in the table trough and allows for Details SOTO rail accessories.

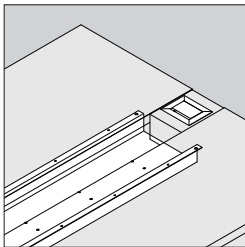

Big Table trough is a painted platinum open steel technology tray that allows for cable management. Either end of the trough comes standard with an anodized aluminum grommet that has a flip-top panel for access to route cables.

Wiring and Cabling

Two anodized aluminum electrical and communication solutions are available as an option to the Big Table with Trough. 15-amp, one-circuit system with a 10' foot electrical cord. These solutions are also style number supported (TS4TPWR and TS4TPWRD) if you chose to field install at a later date.

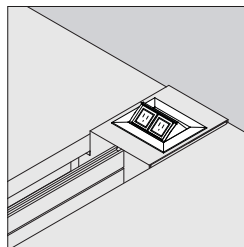

Two receptacles for power (TS4TPWR) are available in place of the standard grommet on each end.

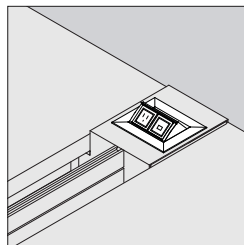

One receptacle and one data (TS4TPWRD) are available in place of the standard grommet on each end. *Tip: Includes open data port. Communication voice/data jacks are customer provided.*

Two receptacle (TS4TPWR1) replaces one of the standard grommets.

One receptacle/one data (TS4TPWRD1) replaces one of the standard grommets.

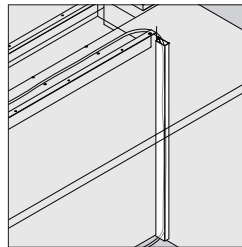

Vertical cord covers (TS4TVWM28 and TS4TVWM40) come in two heights, 28"H and 40"H. Vertical cord covers are used to route electrical cords vertically on Big Table with Trough.

Surface Materials

Big Table and Table Drawer

- Low-Pressure Laminate

Trough

- 4799 Platinum Metallic

Electrical/communication components

- Anodized aluminum

Vertical wire management

- Black plastic

LED Personal Task Lights

► Specifying, page 124

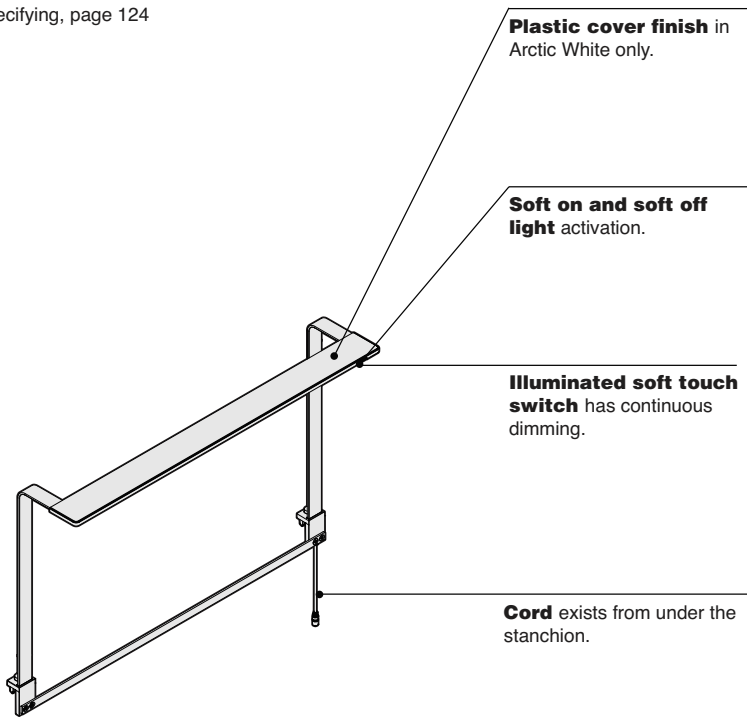

Plastic cover finish in Arctic White only.

Soft on and soft off light activation.

Illuminated soft touch switch has continuous dimming.

Cord exists from under the stanchion.

Product Details

Personal task light includes the lamp and power supply with cord set. Rail-mounted version includes rail brackets. Non rail-mounted version includes Universal Mounting brackets.

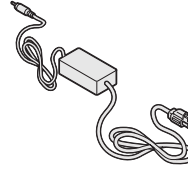

Power supply uses a modular cord with standard two prong plug with integrated low voltage cord and connector to attach to light.
Tip: Energy saving mini-LEDs greatly reduce power use.

Connections

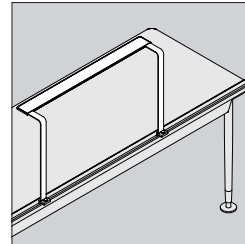

LED personal task light mounts directly to the rail systems of c:scape, Frame-One, Elective Elements 6, Impact, Turnstone Campfire Big Table, and Details SOTO rail.

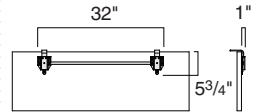
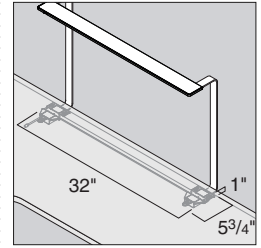

Non rail-mounted LED personal task lights will not work on worksurfaces with knife edge that is longer than 1 1/4", or with modesty panels or modesty screens closer than 6" from the back edge.

Wiring & Cabling

Personal task light includes the lamp and power supply with cord set.

Power supply uses a modular cord with standard two prong plug and integrated low voltage cord and connector to attach to light.

Surface Materials

Housing

- 6009 Arctic White plastic only

Fixture and Stanchions

- 4231 Arctic White
- 4710 Low Gloss Black
- 4799 Platinum Metallic

Cord

- Black plastic only

Actual Dimensions

Depth 6"

Width 30"

Height 17"

Power Supply Cord Set (12')

-Line voltage cord: 6'

-Low voltage cord: 6'

Photometric Data

LED Personal Task Lights

Initial horizontal footcandles for LPTL30 and LPTL30NR
 Worksurface rear

0"	15	14	13	12	11	9	6	6	5	4	3	2	2
3"	21	20	18	17	15	13	11	8	6	5	3	3	2
6"	31	31	29	26	23	19	15	12	9	7	5	3	2
9"	51	50	46	42	36	29	23	18	13	9	6	4	3
12"	82	79	73	64	53	43	32	23	16	11	7	5	3
15"	109	105	96	83	68	53	39	27	19	12	8	6	4
18"	105	102	93	81	66	51	37	27	18	12	9	6	4
21"	76	75	69	59	50	39	30	22	16	11	7	5	4
24"	48	47	44	39	33	27	21	16	12	9	6	5	3
27"	29	28	27	24	21	17	14	11	9	7	5	4	3
30"	18	18	17	16	14	12	10	8	7	5	4	3	2
CL	3"	6"	9"	12"	15"	18"	21"	24"	27"	30"	33"	36"	
	Worksurface front												

Mobile Storage Cabinet Facts

Mobile storage cabinets and storage cabinet wardrobes are offered as left-hand or right-hand units in Low-Pressure Laminate with two adjustable shelves.

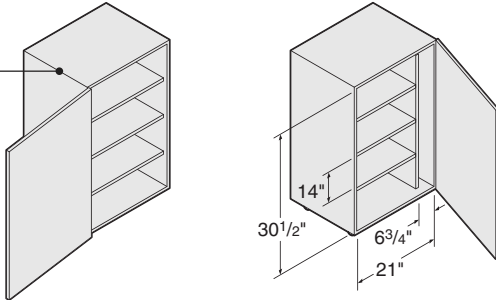

Storage cabinets can be used with 40"H Big Tables and Big Tables with Trough or as freestanding storage units.

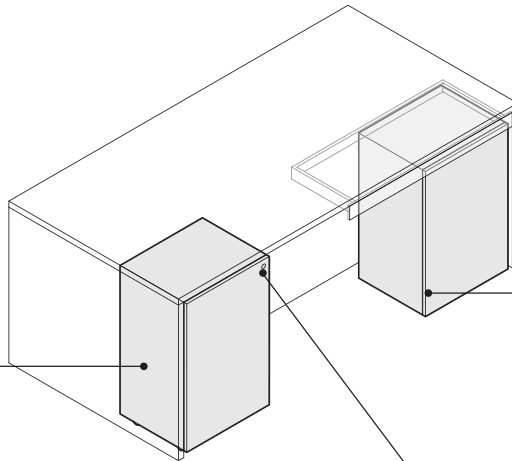

Mobile storage cabinets ship standard with casters. When mobile storage cabinets are intended to be used underneath a table drawer, the glide option will need to be selected to provide enough clearance underneath the drawer.

Storage cabinets and wardrobe have an optional front-removable lock.

Product Details

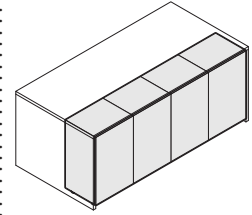

Up to four mobile storage cabinets can fit up to four per side underneath a Big Table.

Surface Materials

Mobile Storage Cabinets and Storage Cabinet Wardrobe

- Low-Pressure Laminate

Actual Dimensions

Depth	18 1/2"
Width	23"
Height (with casters)	38"
Height (with glides)	35"

Big Lounge, Screen, and Big Lamp Facts

Big Lounge, Screen, and Big Lamp Facts

Big Lounge comes standard armless with black plastic feet. Available options include single or multiple fabrics on back and seat and Cal TB 133 Fire Code Seating.

Big Lamp has a painted steel base with fabric lamp shade and white diffuser. At a height of 7'-9", the Big Lamp can be installed in a room with an 8' high ceiling or taller. 15-amp plug with 9' electrical cord and an on/off foot switch.

Tip: Consult local electrical codes if a Big Lamp is placed near ceiling sprinkler system.

Screen is constructed with a steel frame and a mesh sock. Screens are handed. Right-hand and left-hand versions are available.

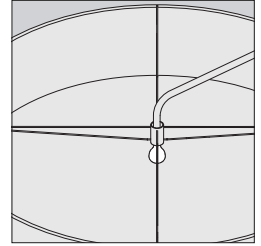
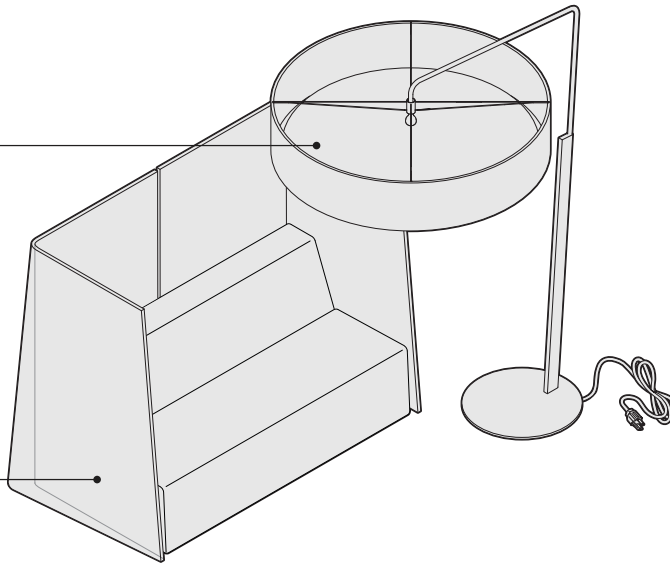

Light bulb is not included. Use a 100 watt A19 incandescent bulb. A compact fluorescent bulb can be used as long as the overall length does not exceed 47¹/₁₆".

Surface Materials

Big Lounge

- Fabric Price Groups 1-10
- COM

Big Lamp

- Painted steel base
- Fabric screen and white diffuser

Screen

- Mesh: T615 Sultry Smoke

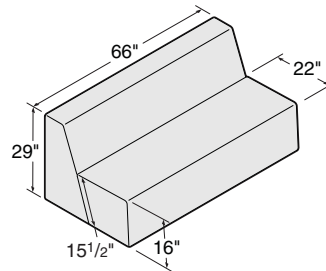
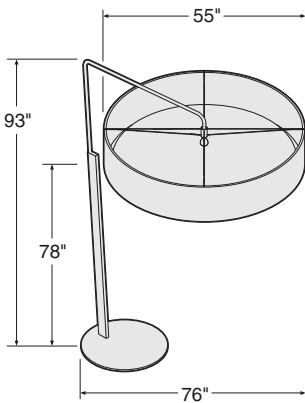

Product Details

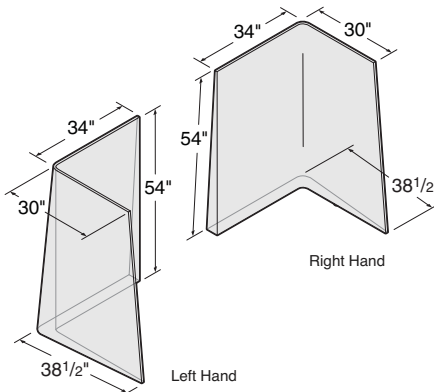

Screens are available in left- and right-hand versions.

Actual Dimensions

Big Lounge

Depth	32"
Width	66"
Height	29"

Big Lamp

Depth	76"
Width	55"
Height	93"

Shade

Diameter	55"
----------	-----

Half Lounge and Wedge Facts

Half Lounge comes standard armless with black plastic feet. Available options include single or multiple fabrics on back and seat and Cal TB 133 Fire Code Seating.

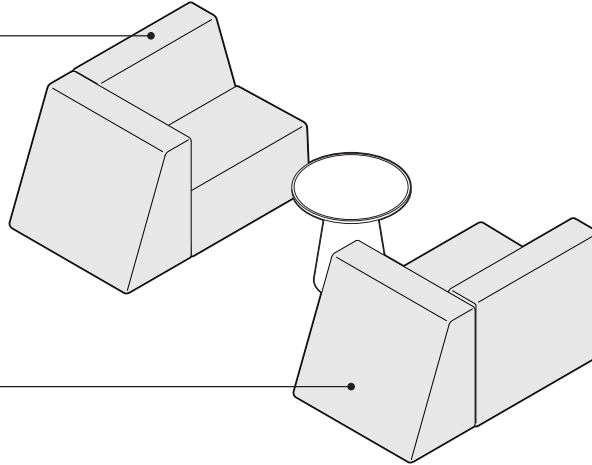

Wedge comes standard with black plastic feet and stability brackets. Independent Wedges and Half Lounges may be positioned into any configuration without moving or removing the stability brackets.

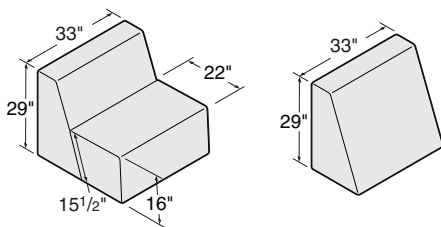

Actual Dimensions

	Half Lounge	Wedge
Depth	32"	17 ⁷ / ₈ "
Width	33"	33"
Height	29"	29"

Product Details

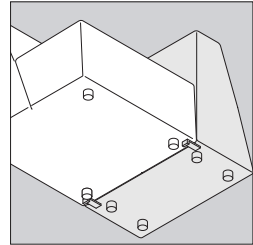

Wedges connected to the side of a Half Lounge would use the stability brackets facing towards the back as they come standard.

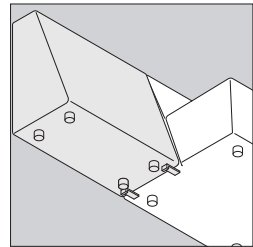

Wedges connected to the back of a Half Lounge or in-line with another Wedge would require moving the stability brackets to the side.

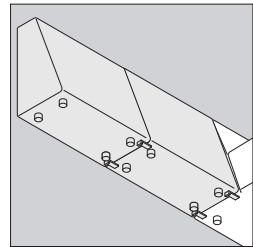

No more than two Wedges can be attached to a single lounge. Wedges can be freestanding, either alone or next to the Big Lounges or Half Lounges.

Surface Materials

Half Lounge and Wedge

- Fabric Price Group 1-10
- COM

Personal Table and Paper Table Facts

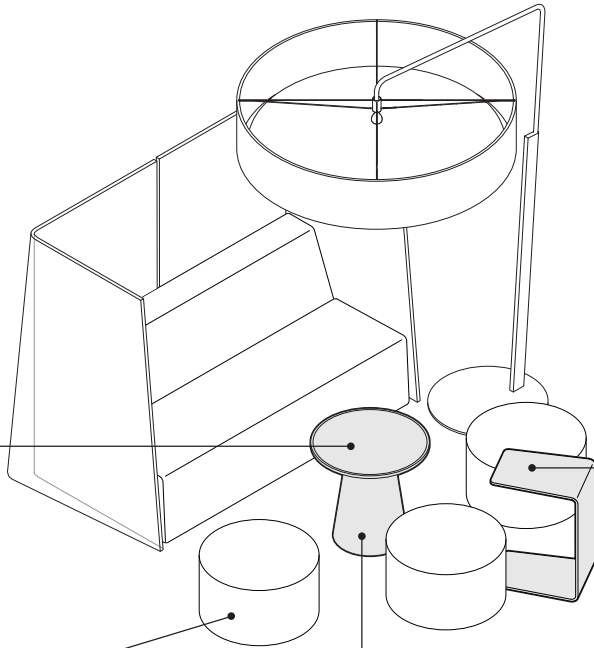

Paper table has three top configurations:

- Paper (installed over steel table top tray)
- Glass (installed over steel table top tray)
- Steel table top tray

align round ottoman shown in this Campfire setting includes the low-profile glide option. This option decreases the seat height from 19" down to 16". To specify go to the align ottoman on page 191.

Personal table is constructed of bent plywood with rift-cut natural oak veneer finish. It nests underneath Big Lounge and can be used for a writing surface or laptop.
Tip: The angle design is not approved to be used for food or drinks. The personal table is not intended to be sat or stood on.

Paper table is constructed with laminate base, plastic rotating table top, and steel table top tray.

Product Details

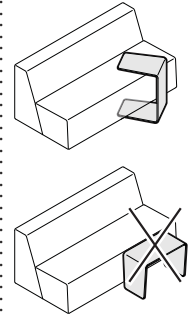

Personal table is designed to be used in the vertical position only.

Surface Materials

- Paper Table Base**
 - Low-Pressure Laminate
- Paper Table Rotating Table Top**
 - Plastic: Arctic White
- Paper Table Top Tray**
 - Steel: Arctic White paint
- Personal Table**
 - 3611 Natural Oak Veneer

Actual Dimensions

Paper Table

Depth	18"
Width	18"
Height	23½"

Personal Table

Depth	19½"
Width	14"
Height	26"

Big Tables

Standard Includes	Required to Specify
-------------------	---------------------

- | | | |
|--|--|--|
| <ul style="list-style-type: none"> ▶ Need help? Product details, page 110 | <ul style="list-style-type: none"> • 1 3/8"-thick worksurface center and end panel: Low-Pressure Laminate • 3 mm radius edge band 4 top sides: default color to match laminate • 1 mm radius edge band vertical: default color to match laminate • Adjustable leveling glides • Shipped ready to assemble | <ul style="list-style-type: none"> 1 Style number 2 Low-Pressure Laminate color number for table top, center, and end panel ▶ See <i>Surface Materials</i>, page 133. |
|--|--|--|

Related Products

- | | |
|---|--|
| <ul style="list-style-type: none"> • Mobile storage cabinets and wardrobes • Table drawer | <ul style="list-style-type: none"> ▶ Page 121 ▶ Page 120 |
|---|--|

Specification Information				
---------------------------	--	--	--	--

• Dimensions			• Style	• U.S.
D	W	H	Number	Price
48"	96"	28"	TS4TL28	\$1581

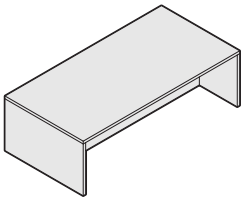

48"	96"	40"	TS4TL40	\$1768
-----	-----	-----	----------------	--------

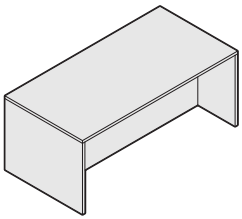

For Canadian Pricing
 Multiply U.S. Price by the Canadian price factor.
 ▶ See page 1 for details.

Big Tables with Trough

Standard Includes		Required to Specify
<ul style="list-style-type: none"> ▶ Need help? Product details, page 110 	<ul style="list-style-type: none"> • 1 3/8"-thick worksurface center and end panel: Low-Pressure Laminate • 3 mm radius edge band 4 top sides: default color to match laminate • 1 mm radius edge band vertical: default color to match laminate • Technology trough: 4799 Metallic Platinum • Grommet on each end of trough: anodized aluminum • Adjustable leveling glides • Shipped ready to assemble 	<ul style="list-style-type: none"> 1 Style number 2 Low-Pressure Laminate color number for table top, center, and end panel ▶ See <i>Surface Materials</i>, page 133.

Tip: Pop-up receptacles come with a 10' cord.

Tip: For use in Chicago, use TS4TPWR1 or TS4TPWRD1 pop-up power receptacle and data only.

Options	U.S. Price	Required to Specify
Receptacles <ul style="list-style-type: none"> • Pop-up receptacle: set of 2 power on each end • Pop-up receptacle: set of 1 power, 1 data on each end 	<ul style="list-style-type: none"> +\$655 +\$655 	<ul style="list-style-type: none"> Specify with 2 power receptacle and specify paint color number. Specify with 1 power/1 data receptacle and specify paint color number.
Center Rail <ul style="list-style-type: none"> • Anodized aluminum 	<ul style="list-style-type: none"> +\$260 	<ul style="list-style-type: none"> Specify with center rail.
Related Products <ul style="list-style-type: none"> • Mobile storage cabinets and wardrobes • Table drawer • Data management and power 		<ul style="list-style-type: none"> ▶ Page 121 ▶ Page 120 ▶ Page 132

Specification Information

Dimensions			Style	U.S.
D	W	H	Number	Base Price
48"	96"	28"	TS4TLT28	\$1862

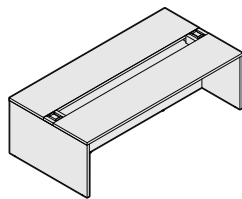

48"	96"	40"	TS4TLT40	\$2049
-----	-----	-----	-----------------	--------

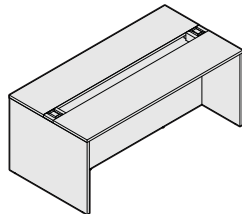

 **For Canadian Pricing**
 Multiply U.S. Price by the Canadian price factor.
 ▶ See page 1 for details.

Table Accessories

Table Drawer

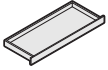

Tip: If mobile storage cabinets or wardrobe is used underneath a table drawer, storage cabinets or wardrobe will require the glide option instead of casters in order to clear the table drawers.

Standard Includes	Required to Specify
<ul style="list-style-type: none"> ▶ Need help? Product details, page 110 • Drawer: Low-Pressure Laminate • Black laminate drawer interior • Attachment hardware 	<ul style="list-style-type: none"> 1 Style number 2 Low-Pressure Laminate color number for drawer ▶ See <i>Surface Materials</i>, page 133.

Related Products	
<ul style="list-style-type: none"> • Big Table • Big Table with trough 	<ul style="list-style-type: none"> ▶ Page 118 ▶ Page 119

Specification Information				
• Dimensions			• Style	• U.S.
D	W	H	Number	Price
18"	46"	3"	TS4TLDRW	\$364

Center Rail



Standard Includes	Required to Specify
<ul style="list-style-type: none"> ▶ Need help? Product details, page 110 • Rail: anodized aluminum • Attachment hardware 	<ul style="list-style-type: none"> Style number

Related Products	
<ul style="list-style-type: none"> • Big Table with trough • Details SOTO accessories 	<ul style="list-style-type: none"> ▶ Page 119 ▶ Page 226

Specification Information				
• Dimensions			• Style	• U.S.
D	W	H	Number	Price
3 1/4"	80"	4 1/2"	TS4TRAIL	\$260



For Canadian Pricing
 Multiply U.S. Price by the Canadian price factor.
 ▶ See page 1 for details.

Tip: Remember to specify lock cylinder and key.
 ▶ Lock cylinders, page 265

Standard Includes		Required to Specify
▶ Need help? Product details, page 114	<ul style="list-style-type: none"> Mobile storage cabinet: Low-Pressure Laminate Two, height-adjustable shelves Wardrobe on one side, if selected Casters Shipped assembled 	1 Style number 2 Low-Pressure Laminate color number for storage cabinet 3 Options, if selected (see below) ▶ See <i>Surface Materials</i> , page 133.

Options	U.S. Price	Required to Specify
Lock	<ul style="list-style-type: none"> 9201 Polished Chrome +\$107 9250 Ember Chrome +\$107 	Specify with 9201 Polished Chrome. Specify with 9250 Ember Chrome.
Glides	<ul style="list-style-type: none"> Glides 	No cost Specify with glides.
Related Products	<ul style="list-style-type: none"> Big Tables Big Tables with trough 	▶ Page 118 ▶ Page 119

Specification Information				
Dimensions			Style	U.S.
D	W	H	Number	Base Price
:	:	:	:	:

Storage Cabinets

Left-hand

18½"	23"	38"	TS4TSLH	\$910
:	:	:	:	:

Right-hand

18½"	23"	38"	TS4TSRH	\$910
:	:	:	:	:

Storage Cabinet Wardrobes

Left-hand

18½"	23"	38"	TS4TSLH	\$910
:	:	:	:	:

Right-hand

18½"	23"	38"	TS4TSRH	\$910
:	:	:	:	:

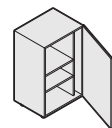
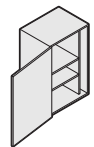
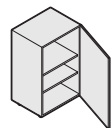
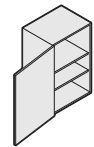

 **For Canadian Pricing**
 Multiply U.S. Price by the Canadian price factor.
 ▶ See page 1 for details.

Big Lamp

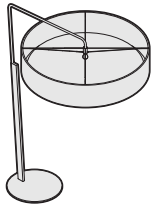

Tip: Shade diameter is 55".

Tip: Bottom of shade is 78" off of the floor.

Standard Includes	Required to Specify
-------------------	---------------------

- | | | |
|--|--|---|
| <ul style="list-style-type: none"> ▶ Need help? Product details, page 115 | <ul style="list-style-type: none"> • Lamp base: paint • Lamp shade: upholstery • 9' cord with three-prong plug • Shipped ready to assemble | <ul style="list-style-type: none"> 1 Style number 2 Paint color number for lamp base 3 Upholstery color number for lamp shade ▶ See <i>Surface Materials</i>, page 133. |
|--|--|---|

Related Products

- | | |
|--|--|
| <ul style="list-style-type: none"> • a light round ottoman with low-profile glide | <ul style="list-style-type: none"> ▶ Page 191 |
|--|--|

Specification Information				
---------------------------	--	--	--	--

• Dimensions			• Style	• U.S.
D	W	H	Number	Price
55"	76"	93"	TS4TBL	\$1560



For Canadian Pricing

Multiply U.S. Price by the Canadian price factor.

▶ See page 1 for details.



Standard Includes	Required to Specify
<ul style="list-style-type: none"> ▶ Need help? Product details, page 117 • Personal table: 3611 Natural Oak Veneer 	<ul style="list-style-type: none"> Style number

Specification Information				
• Dimensions			• Style	• U.S.
D	W	H	Number	Price
19½"	14"	26"	TS4TWP	\$447



 **For Canadian Pricing**
 Multiply U.S. Price by the Canadian price factor.
 ▶ See page 1 for details.

LED Personal Task Lights

Standard Includes		Required to Specify
<ul style="list-style-type: none"> ▶ Need help? Product details, page 112 	<ul style="list-style-type: none"> • Housing: 6009 Arctic White plastic only • Fixture and stanchions: paint • Power supply with 12' cordage (6' from power supply to power outlet, 6' from power supply to fixture) • Soft touch switch • Ultra energy efficient LED light source • Polycarbonate matte film diffuser • Continuous dimming 	<ul style="list-style-type: none"> 1 Style number 2 Paint color number for fixture and stanchions: <ul style="list-style-type: none"> 4231 Arctic White 4710 Low Gloss Black 4799 Platinum Metallic

Related Products	
<ul style="list-style-type: none"> • c:scape desk • FrameOne bench • Details SOTO rail • Impact • Technology zone integral rail • Worksurfaces and freestanding desks • Campfire Big Table 	<ul style="list-style-type: none"> ▶ See <i>c:scape & media:scape Specification Guide.</i> ▶ See <i>FrameOne Specification Guide.</i> ▶ See <i>Details SpecGuide.</i> ▶ See <i>Wood Casegoods and Tables Specification Guide.</i> ▶ See <i>Elective Elements 6 Specification Guide.</i> ▶ See <i>Answer Specification Guide.</i> ▶ See <i>page 118.</i>

Specification Information

• Dimensions			• Lamp	• Style	• U.S.
D	W	H	Wattage	Number	Price
6"	30"	17"	14 watts	LPTL30	\$565

Rail-Mounted LED Personal Task Light

6"	30"	17"	14 watts	LPTL30	\$565
----	-----	-----	----------	--------	-------

Non Rail-Mounted LED Personal Task Light

6"	30"	17"	14 watts	LPTL30NR	\$565
----	-----	-----	----------	----------	-------

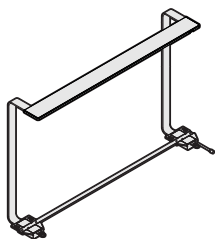
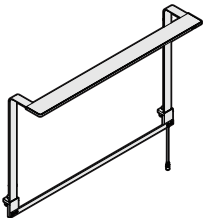

Tip: Non rail-mounted LED personal task lights will not work on worksurfaces with knife edge that is longer than 1 1/4", or with modesty panels or modesty screens closer than 6" from the back edge.



For Canadian Pricing
 Multiply U.S. Price by the Canadian price factor.
 ▶ See page 1 for details.

Paper Table and Accessories

Paper Table



Tip: If glass option is selected, standard stack of paper will be omitted.

	Standard Includes	Required to Specify
▶ Need help? Product details, page 117	<ul style="list-style-type: none"> Table base: High-Pressure Laminate Plastic rotating table top: arctic white Steel table top tray: arctic white Stack of paper: 44 sheets Shipped assembled 	<ul style="list-style-type: none"> 1 Style number 2 High-Pressure Laminate color number for table base 3 Options, if selected (see below) ▶ See <i>Surface Materials</i>, page 133.

	Options	U.S. Price	Required to Specify
Paper	<ul style="list-style-type: none"> Omit paper 	-\$120	Specify with <i>omit paper</i> .
Glass	<ul style="list-style-type: none"> Glass 	+\$ 15	Specify with <i>glass</i> .
Related Products	<ul style="list-style-type: none"> Paper Glass 		<ul style="list-style-type: none"> ▶ See below ▶ Page 126

Specification Information				
Dimensions			Style	U.S.
D	W	H	Number	Base Price
25"	25"	23½"	TS4TPT	\$900

Paper



	Standard Includes	Required to Specify
▶ Need help? Product details, page 117	<ul style="list-style-type: none"> Paper: 44 sheets 	Style number

Related Products
<ul style="list-style-type: none"> Paper table

Specification Information	
Style Number	U.S. Price
TS4TPTP	\$120

 **For Canadian Pricing**
Multiply U.S. Price by the Canadian price factor.
▶ See page 1 for details.

Glass



Standard Includes	Required to Specify
-------------------	---------------------

- | | |
|--|--------------------------------------|
| ▶ Need help?
Product details,
page 117 | • Tempered glass

Style number |
|--|--------------------------------------|

Related Products

- | | |
|---------------|------------|
| • Paper table | ▶ Page 125 |
|---------------|------------|

Specification Information

• Style • Number	• U.S. • Price
TS4TPTG	\$135
:	:
:	:



For Canadian Pricing
 Multiply U.S. Price by the
 Canadian price factor.
 ▶ See page 1 for details.

Standard Includes	Required to Specify
<ul style="list-style-type: none"> ▶ Need help? Product details, page 115 • Mesh screen: T615 Sultry Smoke • Frame: black paint • Ships ready to assemble 	<ul style="list-style-type: none"> 1 Style number 2 Fabric color number for mesh screen ▶ See <i>Surface Materials</i>, page 133.

Related Products
<ul style="list-style-type: none"> • Big Lamp ▶ Page 122 • Big Lounge ▶ Page 128

Specification Information		
• Dimensions	• Style	• U.S.
H	Number	Price

Screens

Right-Hand

54"	TS4TSCRNR	\$884
:	:	:

Left-Hand

54"	TS4TSCRNL	\$884
:	:	:

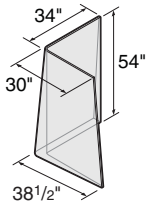
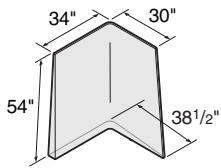

 **For Canadian Pricing**
 Multiply U.S. Price by the Canadian price factor.
 ▶ See page 1 for details.

Big Lounge

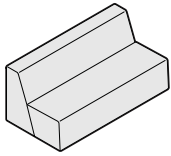

Standard Includes	Required to Specify
<ul style="list-style-type: none"> ▶ Need help? Product details, page 115 Fully upholstered armless lounge: fabric price group 1 Foot: black plastic Shipped fully assembled Meets Cal. 116 and 117 requirements 	<ul style="list-style-type: none"> 1 Style number 2 Fabric color number for upholstery 3 Options, if selected (see below) ▶ See <i>Surface Materials</i>, page 133.

Surface Materials	Options	U.S. Price	Required to Specify
	Single upholstery fabric		
	<ul style="list-style-type: none"> Fabric price group 1 Fabric price group 2 Fabric price group 3 Fabric price group 4 Fabric price group 5 Fabric price group 6 Fabric price group 7 Fabric price group 8 Fabric price group 9 Fabric price group 10 Customer's Own Material (COM) Fire Code Seating (FCS) 	<ul style="list-style-type: none"> No cost +\$ 33 +\$129 +\$232 +\$416 +\$435 +\$501 +\$713 +\$870 +\$911 +\$ 32 +\$520 	<ul style="list-style-type: none"> Specify fabric color number. Specify fabric color number. Specify fabric color number. Specify fabric color number. Specify fabric color number. Specify fabric color number. Specify fabric color number. Specify fabric color number. Specify fabric color number. Specify fabric color number. Specify fabric color number. ▶ See Understanding Customer's Own Material (COM) Add suffix F to style number and specify fabric color number.

Example: TS3BC with T015 on seat and T016 on back.

Tip: Big Lounge is available with multiple fabrics. ▶ See at right to specify.

Tip: When specifying multiple COM fabrics, indicate all surfaces where COM applies. Example: TS3BCM with Designtex 1234 on seat and Designtex 5678 on back.

	Multiple upholstery fabric		
	<ul style="list-style-type: none"> Different fabric on seat and back 	<ul style="list-style-type: none"> +\$ 57 	<ul style="list-style-type: none"> Add suffix M to Big Lounge chair style number and select fabric color number for: 1 Seat, 2 Back
	① Fabric on seat		
	<ul style="list-style-type: none"> Fabric price group 1 Fabric price group 2 Fabric price group 3 Fabric price group 4 Fabric price group 5 Fabric price group 6 Fabric price group 7 Fabric price group 8 Fabric price group 9 Fabric price group 10 Customer's Own Material (COM) Fire Code Seating (FCS) 	<ul style="list-style-type: none"> No cost +\$ 15 +\$ 55 +\$100 +\$179 +\$186 +\$215 +\$306 +\$373 +\$391 +\$ 16 +\$260 	<ul style="list-style-type: none"> Specify fabric color number. Specify fabric color number. Specify fabric color number. Specify fabric color number. Specify fabric color number. Specify fabric color number. Specify fabric color number. Specify fabric color number. Specify fabric color number. Specify fabric color number. Specify fabric color number. ▶ See Understanding Customer's Own Material (COM) Add suffix F to style number and specify fabric color number.
	② Fabric on back		
	<ul style="list-style-type: none"> Fabric price group 1 Fabric price group 2 Fabric price group 3 Fabric price group 4 Fabric price group 5 Fabric price group 6 Fabric price group 7 Fabric price group 8 Fabric price group 9 Fabric price group 10 Customer's Own Material (COM) Fire Code Seating (FCS) 	<ul style="list-style-type: none"> No cost +\$ 22 +\$ 89 +\$163 +\$295 +\$309 +\$356 +\$508 +\$620 +\$649 +\$ 17 +\$260 	<ul style="list-style-type: none"> Specify fabric color number. Specify fabric color number. Specify fabric color number. Specify fabric color number. Specify fabric color number. Specify fabric color number. Specify fabric color number. Specify fabric color number. Specify fabric color number. Specify fabric color number. Specify fabric color number. ▶ See Understanding Customer's Own Material (COM) Add suffix F to style number and specify fabric color number.

Related Products	
<ul style="list-style-type: none"> alight round ottoman with low profile glide option 	▶ Page 191



For Canadian Pricing
Multiply U.S. Price by the Canadian price factor.
▶ See page 1 for details.

Specification Information

Dimensions			Style Number	U.S. Base Price
D	W	H		
32"	66"	29"	TS3BC	\$2392

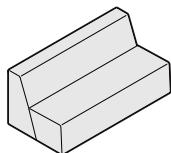

 **For Canadian Pricing**
 Multiply U.S. Price by the
 Canadian price factor.
 ▶ See page 1 for details.

Half Lounge and Wedge

Half Lounge

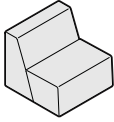

Standard Includes	Required to Specify
<ul style="list-style-type: none"> ▶ Need help? Product details, page 116 • Fully upholstered armless lounge: fabric price group 1 • Foot: black plastic • Shipped fully assembled • Meets Cal. 116 and 117 requirements 	<ul style="list-style-type: none"> 1 Style number 2 Fabric color number for upholstery 3 Options, if selected (see below) ▶ See <i>Surface Materials</i>, page 133.

Options	U.S. Price	Required to Specify
Surface Materials		
Single upholstery fabric		
• Fabric price group 1	No cost	Specify fabric color number.
• Fabric price group 2	+\$ 17	Specify fabric color number.
• Fabric price group 3	+\$ 58	Specify fabric color number.
• Fabric price group 4	+\$125	Specify fabric color number.
• Fabric price group 5	+\$220	Specify fabric color number.
• Fabric price group 6	+\$238	Specify fabric color number.
• Fabric price group 7	+\$250	Specify fabric color number.
• Fabric price group 8	+\$360	Specify fabric color number.
• Fabric price group 9	+\$420	Specify fabric color number.
• Fabric price group 10	+\$445	Specify fabric color number.
• Customer's Own Material (COM)	+\$ 32	▶ See Understanding Customer's Own Material (COM)
• Fire Code Seating (FCS)	+\$300	Add suffix F to style number and specify fabric color number.

Example: TS3HL with T015 on seat and T016 on back.

Tip: Half Lounge is available with multiple fabrics.
▶ See at right to specify.

Tip: When specifying multiple COM fabrics, indicate all surfaces where COM applies. Example: TS3HLM with Designtex 1234 on seat and Designtex 5678 on back.

Multiple upholstery fabric		
• Different fabric on seat and back	+\$ 57	Add suffix M to Half Lounge chair style number and select fabric color number for: 1 Seat, 2 Back
① Fabric on seat		
• Fabric price group 1	No cost	Specify fabric color number.
• Fabric price group 2	+\$ 11	Specify fabric color number.
• Fabric price group 3	+\$ 22	Specify fabric color number.
• Fabric price group 4	+\$ 50	Specify fabric color number.
• Fabric price group 5	+\$ 75	Specify fabric color number.
• Fabric price group 6	+\$138	Specify fabric color number.
• Fabric price group 7	+\$150	Specify fabric color number.
• Fabric price group 8	+\$160	Specify fabric color number.
• Fabric price group 9	+\$220	Specify fabric color number.
• Fabric price group 10	+\$245	Specify fabric color number.
• Customer's Own Material (COM)	+\$ 16	▶ See Understanding Customer's Own Material (COM)
• Fire Code Seating (FCS)	+\$300	Add suffix F to style number and specify fabric color number.
② Fabric on back		
• Fabric price group 1	No cost	Specify fabric color number.
• Fabric price group 2	+\$ 16	Specify fabric color number.
• Fabric price group 3	+\$ 46	Specify fabric color number.
• Fabric price group 4	+\$ 85	Specify fabric color number.
• Fabric price group 5	+\$150	Specify fabric color number.
• Fabric price group 6	+\$155	Specify fabric color number.
• Fabric price group 7	+\$165	Specify fabric color number.
• Fabric price group 8	+\$250	Specify fabric color number.
• Fabric price group 9	+\$270	Specify fabric color number.
• Fabric price group 10	+\$275	Specify fabric color number.
• Customer's Own Material (COM)	+\$ 16	▶ See Understanding Customer's Own Material (COM)
• Fire Code Seating (FCS)	+\$300	Add suffix F to style number and specify fabric color number.



For Canadian Pricing
Multiply U.S. Price by the Canadian price factor.
▶ See page 1 for details.

Specification Information

Dimensions			Style Number	U.S. Base Price
D	W	H		
32"	33"	29"	TS3HL	\$1380

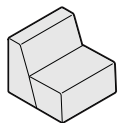

Wedge

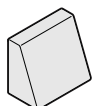

Standard Includes

- Fully upholstered wedge: fabric price group 1
- Foot: black plastic
- Deck stitch detail
- Connecting hardware

Required to Specify

- 1 Style number
 - 2 Fabric color number for upholstery
 - 3 Options, if selected (see below)
- ▶ See *Surface Materials*, page 196.

Options	U.S. Price	Required to Specify
Surface Materials		
Upholstery		
• Fabric price group 1	No cost	Specify fabric color number.
• Fabric price group 2	+\$ 15	Specify fabric color number.
• Fabric price group 3	+\$ 36	Specify fabric color number.
• Fabric price group 4	+\$ 60	Specify fabric color number.
• Fabric price group 5	+\$ 95	Specify fabric color number.
• Fabric price group 6	+\$160	Specify fabric color number.
• Fabric price group 7	+\$200	Specify fabric color number.
• Fabric price group 8	+\$220	Specify fabric color number.
• Fabric price group 9	+\$260	Specify fabric color number.
• Fabric price group 10	+\$295	Specify fabric color number.
• Customer's Own Material (COM)	+\$ 32	Specify fabric color number.
• Fire Code Seating (FCS)	+\$200	
		Add suffix F to the style number and specify fabric color number.

Tip: When specifying Fire Code Seating, specify suffix **F** at the end of the style number.

Example: TS3WGF

Specification Information

Style Number	U.S. Base Price
TS3WG	\$825



For Canadian Pricing

Multiply U.S. Price by the Canadian price factor.

▶ See page 1 for details.

Accessories

Vertical Cord Cover



Standard Includes	Required to Specify
-------------------	---------------------

- | | |
|---|--------------|
| <ul style="list-style-type: none"> • Vertical cord cover: black plastic • Attachment hardware | Style number |
|---|--------------|

Related Products

- | | |
|--|--|
| <ul style="list-style-type: none"> • Big Table • Big Table with trough | <ul style="list-style-type: none"> ▶ Page 118 ▶ Page 119 |
|--|--|

Specification Information		
• Length	• Style Number	• U.S. Price

28"	TS4TVWM28	\$21
40"	TS4TVWM40	\$31

Receptacles



Standard Includes	Required to Specify
-------------------	---------------------

- | | |
|---|--------------|
| <ul style="list-style-type: none"> • Receptacle: anodized aluminum • Attachment hardware • 10' electrical cord | Style number |
|---|--------------|

Related Products

- | | |
|---|------------|
| <ul style="list-style-type: none"> • Big Table with trough | ▶ Page 119 |
|---|------------|

Specification Information	
• Style Number	• U.S. Price

--	--

Dual Pop-Up Receptacle, Power on Each End

TS4TPWR	\$655
----------------	-------

Dual Pop-Up Receptacle, One Power and One Data Port on Each End

TS4TPWRD	\$655
-----------------	-------

Dual Pop-Up Receptacle on One End

TS4TPWR1	\$239
-----------------	-------

Dual Pop-Up Receptacle, One Power, One Data Port on One End

TS4TPWRD1	\$239
------------------	-------

Tip: Pop-up receptacles come with a 10' cord.

▶ See Understanding page 110 to understand price differences between power options.



For Canadian Pricing
Multiply U.S. Price by the Canadian price factor.
▶ See page 1 for details.

Surface Materials

► For Surface Materials matrices for all product lines, see page 241

Paint

Applies to:

- Big Table Trough
- 4799 Platinum Metallic

Applies to:

- Big Lamp base
- 4140 Arctic White
- 4799 Platinum Metallic
- 7246 Midnight Metallic

Laminate

Low-Pressure Laminate

Applies to:

- Big Table
- Table drawer
- Mobile Storage Cabinet
- Mobile Storage Cabinet with wardrobe
- 25L5 Virginia Walnut
- 25L6 Blackwood
- 25L8 Clear Walnut
- 25L9 Warm Oak
- 26L1 Natural Cherry
- 2L30 Arctic White
- 2L85 Dune

High-Pressure Laminate

Applies to:

- Paper Table
- 2535 Virginia Walnut
- 2536 Blackwood
- 2538 Clear Walnut
- 2539 Warm Oak

Fabric

Applies to:

- Big Lamp shade
- 5F18 Regis Black
- 5F19 Regis Cinder
- 5S24 Cogent Nickel

Mesh

Applies to:

- Screen
- T615 Sultry Smoke

Wood

Applies to:

- Personal Table
- 3611 Natural Oak

ⓔ = Established

Upholstery

Not every upholstery is available on every chair. Please refer to the upholstery matrix on page 256 before specifying.

Price Group 1

- Buzz2
- Jacks
- Link
- Playground

Price Group 2

- Cogent: Connect
- Cogent: Geode Seating
- Cogent: Geode Vertical
- Cogent: Trails
- Cricket
- Crosswalk
- Nitelights
- Regis2
- Seating Vinyl
- Spyder ⓔ
- Stand In
- Zoe2

Price Group 3

- Cogent: Tides
- Hampstead

Price Group 5

- Bo Peep

Price Group 6

- Brisa

Turnstone Collection by Designtex

Designtex and Turnstone partnered to create an exclusive collection of affordable seating textiles that offer fresh and exciting designs.

This collection of textiles is stocked and available in standard lead-time. Fabrics are supported just like standard fabrics, which makes ordering easy. This program is supported by a swatch card that presents the entire offering. The swatch card is available to order through ad-stock # 08-0000726.

Price Group 3

- Boyne - 3280
- Great Lakes - 3282
- Ludington - 3285

Price Group 4

- Glen Arbor - 3283
- Leland - 3281
- Saugatuck - 3284

Select Surfaces

For information on products within Select Surfaces, including accent paints and fabrics from Designtex, Maharam, and Pollack, please refer to the *Surface Materials Reference Manual* or visit Steelcase.com/selectsurfaces.

Custom Surfaces

Price Group COM (Customer's Own Material)

Fabric Approval and Yardage

To confirm whether a particular COM material has already been tested for use on a specific Steelcase product or to determine actual yardage requirements:

- Visit www.steelcase.com

For additional information regarding Customer's Own Material, call 1.888.STEELCASE (1.888.783.3522) or send an e-mail to lineone@steelcase.com.

Customer's Own Material (COM) Program

The Customer's Own Material (COM) program offers the opportunity for customers to select fabrics that are not offered through the standard Steelcase surface materials program for use on Steelcase products. Once approved, you can place your order. Steelcase will facilitate the entire ordering process and give you a production schedule. Steelcase will order the COM fabric directly from the textile manufacturer. For up-to-date information regarding fabric test results for all COM fabrics and details regarding yardage requirements for most seating lines, visit the COM website on www.steelcase.com. COMs are not covered under the Steelcase warranty.

Soil Retardants

Soil retardants are treatments that provide long-term soil and stain resistance to a fabric without affecting the shade or the integrity of the fabric. The following Steelcase Textiles and Turnstone Collection by Designtex fabrics are available pre-treated with soil retardant:

- Boyne
- Glen Arbor
- Jacks
- Link
- Saugatuck
- Spyder



Seating

Tip: Established finishes are available for delivery in 15 business days.

E = Established



Statement of Line **136**



Understanding and Specifying

Task Chairs

Reply Select **139**

Multipurpose Seating

cobi Select **145**

Uno Select **151**

Scoop **157**

Lounge Seating

Jenny Lounge **163**

Lincoln Lounge **185**

alight Lounge **189**

Crushed Can **193**



Surface Materials **196**

Statement of Line

Seating

Reply Select



Task Chair with mesh back
▶ Page 144

cobi Select



Collaborative Chair with Arms
▶ Page 150

Uno Select



Multi-Purpose High-Back Chair
▶ Page 155

Scoop

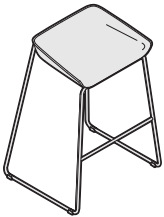

Stool
▶ Page 160

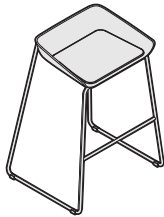

Stool with Upholstered Seat
▶ Page 160

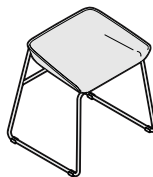

Side Chair
▶ Page 161

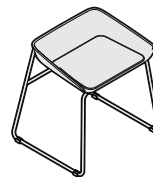

Side Chair with Upholstered Seat
▶ Page 161

Jenny Lounge

Tip: Jenny armless lounge chairs shown comprise full statement of line.

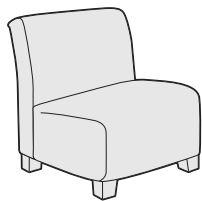

Armless
Lounge Chair
▶ Page 166

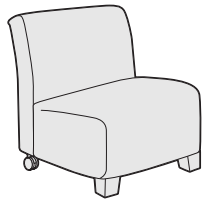

Armless
Lounge Chair
with Casters
▶ Page 166

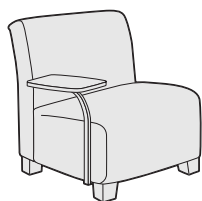

Armless
Lounge Chair
with Tablet Arm
▶ Page 166

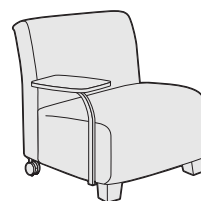

Armless
Lounge Chair
with Casters and
Tablet Arm
▶ Page 166

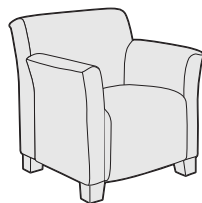

*Lounge Chair
with Arms
▶ Page 168

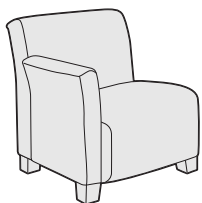

*Lounge Chair
with Arm Right
▶ Page 170

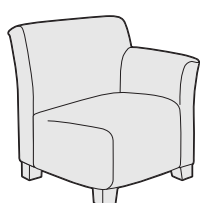

*Lounge Chair
with Arm Left
▶ Page 170

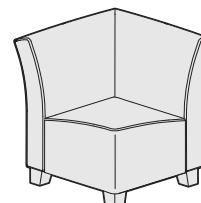

*Corner
Lounge Chair
▶ Page 174

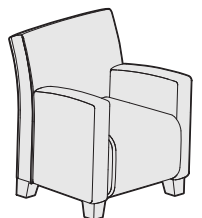

*Club
Lounge Chair
▶ Page 176

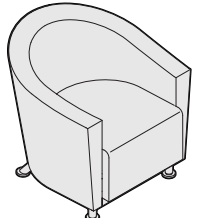

Round Lounge
Chair
▶ Page 178

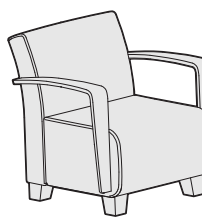

*Lounge Chair
with Wood Arms
▶ Page 180

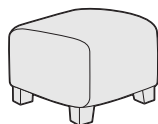

*Ottoman
▶ Page 182

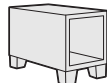

End Table
▶ Page 184

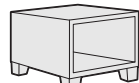

Coffee Table
▶ Page 184

*See specifying pages for availability of casters and tablet arm.

Seating

Statement of Line Seating, continued

Lincoln Lounge

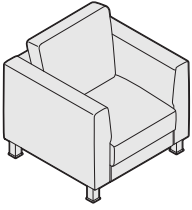

Lincoln Lounge
▶ Page 188

alight Lounge

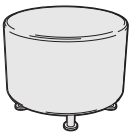

Round Ottoman
▶ Page 191

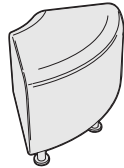

Corner Ottoman
▶ Page 191

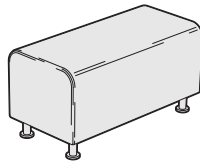

Bench Ottoman
▶ Page 191

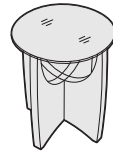

End Table
▶ Page 192



Coffee Table
▶ Page 192

Crushed Can



Small Can
▶ Page 195



Medium Can
▶ Page 195



Large Can
▶ Page 195

Understanding and Specifying Reply Select Task Chair

Product Details

Reply Select	140
Dimensions	142

Specifying

Swivel-Base Work Chair	144
------------------------	-----

Reply Select

Reply Select is a complete family of comfortable, budget-friendly chairs that are as nice to look at as they are to sit in. Reply can take on whatever your workday brings.

Back handle provides a convenient handhold to easily move the chair.

Lumbar height adjusts 4" to provide additional lower back support and is available as an option.

Arm height can adjust independently within a 3¾" range to help relieve upper back and shoulder fatigue.

Five-arm base is black plastic.

Tilt tension adjustment allows you to control the amount of resistance needed for reclining.



Arms, when specified, have a textured plastic arm cap.

Multi-position back lock allows user to lock the backrest in multiple positions.

Seat depth adjusts within a 1½" range to accommodate users of varying leg lengths.

Seat height adjusts within a 5" range with a pneumatic adjustment mechanism.

Casters have hard, dual-wheels that roll smoothly on carpets. They are 2½" for increased mobility. Soft, dual-wheel casters are available as an option for use on hard floors or chair mats.

Product Details

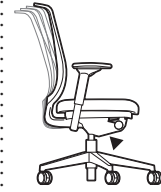

Synchro-tilt mechanism with a natural fluid motion on work chairs keeps users oriented to their work.

Cartoned shipment of Reply work chairs is standard. Reply work chairs ship knocked down in a single carton consisting of four components: back, seat and mechanism, base, and pneumatic. This allows for shipment in a smaller carton. Assembly by a qualified dealer installer is required for work chairs. Assembly instructions are included. No additional tools are required for assembly.

Adjustment Features

Adjustability instructions are included with every swivel-base chair. Instructions can also be found at www.steelcase.com.

Seat Adjustments

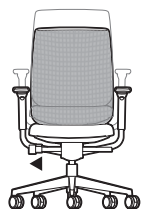

Seat height adjusts pneumatically. To lower, hold handle up while seated. To raise, hold handle up and keep your weight off the chair. Range of adjustability is 5", from 16"H to 21"H.

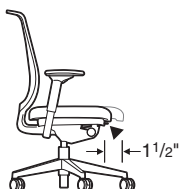

Seat depth adjusts 1/2" (15 1/4"-16 3/4") by pulling handle up. Slide seat forward or back to accommodate various leg lengths. Release handle to lock. Seat depth is a standard feature on work chairs.

Back Adjustments

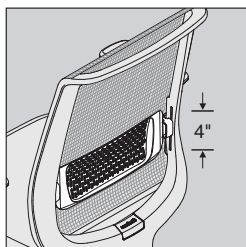

Lumbar height adjusts 4" (6" to 10" from seat) by grabbing exposed tabs and sliding the lumbar support up or down. Available as an option on mesh work chairs only.



Variable back lock (4 positions) Upright setting

Multiple position back lock allows users to recline the back to the desired angle and lock it in place. To lock, recline to desired angle and push back lock handle down. To release, lean forward, lift the handle and apply pressure to the back to disengage the lock.

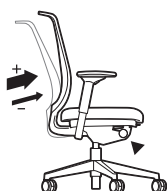

Back tension adjusts by turning knob forward to increase back tension, backward to decrease back tension. This feature is standard on all work chairs.

Arm Adjustments

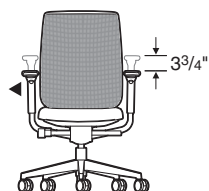

Arm height adjusts independently within a range of 3 3/4" (7 1/2"-11 1/4" from the seat). Push button on outside and under arm cap in while moving arms up or down. Releasing buttons locks arms in position.

Other Features

Soft-wheel casters for hard floors on work chairs are available for specific applications.

Surface Materials

▶ See surface materials on page 196 for specific availability or refer to the *Surface Materials Reference Manual* for further information.

Upholstery

- Fabric
- Fabric with soil-retardant treatment (option)
- Mesh (back only)

Hard components

Chair with swivel-base (frame, outer back, arm cap assembly, and mechanism)

- 6205 Black

Chair with swivel-base (arm tube and base)

- 6205 Black

Casters

- 6205 Black

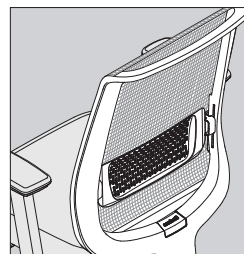

Mesh back on swivel-base models are available with a height-adjustable lumbar option to enhance back support.

All Steelcase seating with standard upholstery fabrics complies with requirements of the State of California Technical Bulletin 117. All standard seating is labeled to be in compliance with California 117.

Programs & Services

Steelcase fire code seating (FCS) is not available on Reply seating.

Local codes may have special requirements for upholstery.

Dimensions

▶ Page 142

Dimensions

Reply Select

Features	Overall Depth	Width	Height	Seat Depth	Functional Seat Depth	Seat Width	Seat Height from Floor	Back Width	Back Height from Seat	Lumbar Height from Seat
----------	---------------	-------	--------	------------	-----------------------	------------	------------------------	------------	-----------------------	-------------------------

Reply Select

Swivel-Base Task Chairs

Mesh Back	24" to 25"	25 ³ / ₄ "	37 ³ / ₄ " to 42 ³ / ₄ "	16 ⁷ / ₈ "	16" to 17 ¹ / ₂ "	18 ¹ / ₂ "	16" to 21"	17 ¹ / ₂ "	22 ⁵ / ₈ "	6" to 10"
-----------	------------	----------------------------------	--	----------------------------------	---	----------------------------------	------------	----------------------------------	----------------------------------	-----------

*Armless models are 1¹/₄" narrower.

**Dimension is 1/2" less when specified with glides.

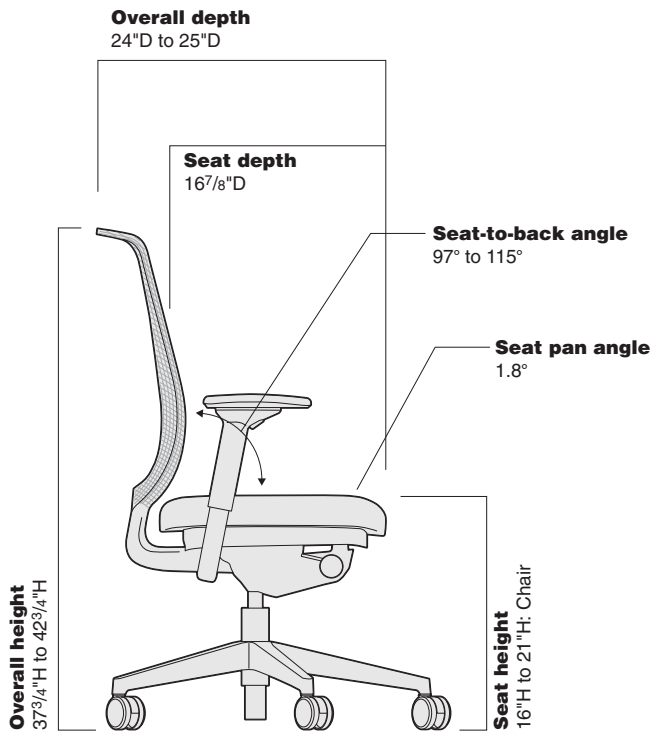
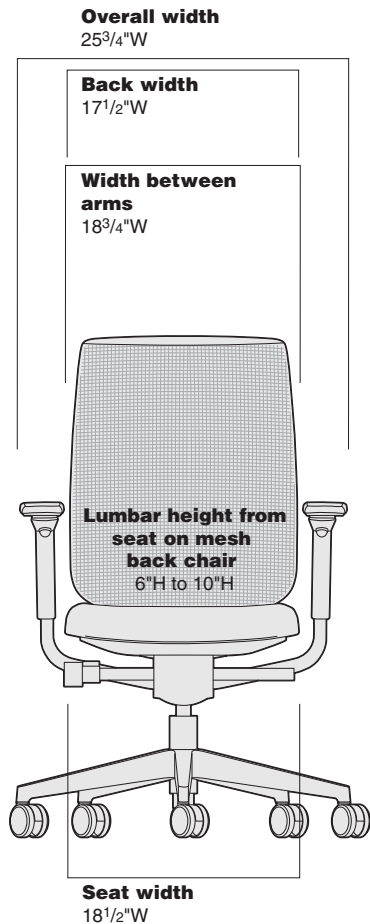

• Width • Between • Arms	• Arm • Height • to Floor	• Arm • Height • from • Seat	• Arm Cap • Pivot • Range	• Angle • Between • Seat and • Back	• Seat • Pan • Angle
--------------------------------	---------------------------------	---------------------------------------	---------------------------------	--	----------------------------

Swivel-Base Work Chairs

18¾"	23⅝" to 32"	7½" to 11¼"	18° inward, 4° outward	97° to 113°	1.8°
------	-------------	-------------	---------------------------	-------------	------

Reply Select

Mesh Back with Standard Upholstery on Seat



Tip: Arms are not included with Reply Select unless you specify the arm options.

Tip: Outer back, mechanism, and optional arm cap assembly are available in 6205 Black only.

Standard Includes		Required to Specify
<ul style="list-style-type: none"> ▶ Need help? Product details, page 140 	<ul style="list-style-type: none"> • Synchro-tilt mechanism • 5" pneumatic seat-height adjustment (16"–21") • Multi-position back lock • Outer back, seat shell, and five-arm plastic base: plastic • 1½" seat depth adjustment • Mesh on back • Standard upholstery design on seat matches mesh color • 2½"-diameter, hard-composition, dual-wheel casters: black 	<ul style="list-style-type: none"> 1 Style number 2 Mesh color number for back 3 Options, if selected (see below) ▶ See <i>Surface Materials</i>, page 196.

Options	U.S. Price	Required to Specify
Surface Materials <ul style="list-style-type: none"> • Upholstery • Fabric price group 1 • Soil-retardant treatment applied to upholstery fabric 	<ul style="list-style-type: none"> No cost +\$ 26 	<ul style="list-style-type: none"> Specify fabric color number. Specify with <i>soil-retardant treatment</i>.
Arms <ul style="list-style-type: none"> • Height-adjustable arms, soft arm caps 	+\$110	Specify with <i>height-adjustable arms</i> .
Lumbar Height <ul style="list-style-type: none"> • 4" travel for additional lumbar support 	+\$ 46	Specify with <i>adjustable lumbar height</i> .
Casters <ul style="list-style-type: none"> • Soft, dual-wheel casters for use on hard floors 	+\$ 26	Specify with <i>soft casters</i> .

Specification Information	
Style Number	U.S. Base Price
TS466EXP	\$827

▶ Detailed dimensions, page 142



For Canadian Pricing

Multiply U.S. Price by the Canadian price factor.

▶ See page 1 for details.

Understanding and Specifying cobi Select Multipurpose Seating



Product Details

cobi Select	146
Dimensions	148



Specifying

cobi Select	150
-------------	-----

cobi Select

cobi is collaborative seating for teams that helps people move freely, change postures, and stay energized and comfortable.

Flexible top edge allows for multiple postures while maintaining support and comfort.

Flexing fingers in back offer support while moving and conforming to the user.

Weight-activated mechanism provides support by automatically responding to the users movements.

Five-arm base is standard.

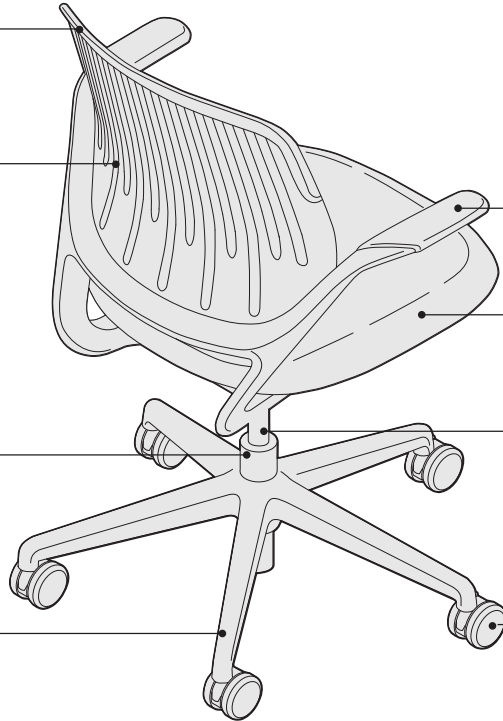

Arms are constructed of a soft durable rubber compound.

Flexible seat edge on all 3-sides supports multiple postures while relieving thigh pressure.

Seat height adjusts with a 5" range from 15½"H to 20½"H with a pneumatic adjustment mechanism.

Hard, dual-wheel casters are standard for use on carpets. Soft, roll-control, dual-wheel casters are available for use on hard floors or chair mats.

Product Details



Weight-activated mechanism provides individual support without a tension control by intuitively sensing and supporting the users center of gravity.

Adjustment Features

Seat Adjustments

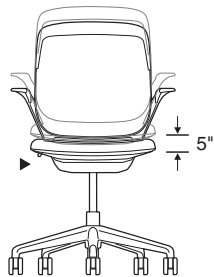

Seat height adjusts

pneumatically. To lower, pull lever up while seated. To raise, pull lever up and keep your weight off the chair.

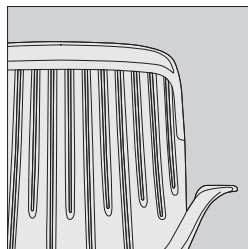

Flexing fingers in back

promote movement and provide support for a wide range of postures.

Soft roll-control caster option

features an internal brake that activates when the chair is not under load to reduce shifting when user stands up.

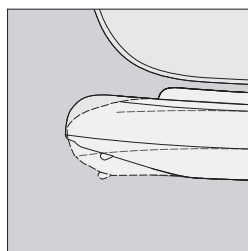

Flexing seat edge on all 3-sides

supports multiple postures while relieving thigh pressure.

Surface Materials

▶ See surface materials on page 196 for specific availability or refer to the *Surface Materials Reference Manual* for further information.

Back Upholstery

- Connect 3D (back only)

Seat Upholstery

- Cogent: Connect (seat only)

Outer Back

- 6295 Near Black

Arm Caps, Top Edge, and Casters

- 6205 Black

All Steelcase seating with standard upholstery fabrics

complies with requirements of the State of California Technical Bulletin 117. All standard seating is labeled to be in compliance with California 117.

Programs & Services

▶ See the *Surface Materials Reference Manual* for further detail about programs and services offered for seating.

Soil-retardant treatment is available on all other seating fabrics at an additional upcharge per seating unit. To order this option, please select "Soil-Retardant Treatment" under "Optional Accessories."

For soil-retardant treatment on COMs, please select "Soil-Retardant Treatment" under "Optional Accessories." Minimums or additional yardage may be required. Please contact the vendor directly for specific information.

Extended lead times may be necessary for this service.

Contact your Steelcase Solutions Fulfillment Team Representative at 1.888.STEELCASE (1.888.783.3522) or send an e-mail to lineone@steelcase.com.

Fire Codes

▶ See pages 258–259 for upholstery fabrics available for use with FCS modification.

Steelcase offers Fire Code Seating modification (FCS) on nearly all seating models. The most rigorous fire codes in the nation have been developed in California, and the Steelcase FCS modification is designed to meet those codes. Fire Code Seating (FCS) indicates that a product is constructed to meet the strict fire code requirements of high public occupancy areas such as theaters, meeting rooms, and lobbies. The FCS standards will meet both the State of California Home Furnishing Technical Bulletin 133 (Cal TB 133) and Boston Fire Code (BFC). Boston adopted the California Home Furnishing Technical Bulletin TB 133 test standard in 1992.

Local codes may have special requirements for upholstery.

Dimensions

▶ Page 148

Resources

Printed Materials

▶ cobi Brochure (09-0000049)

Dimensions

cobi Select

Features	Overall Depth	Width	Height	Seat Depth	Functional Seat Depth	Seat Width	Seat Height from Floor	Back Width	Back Height from Seat
cobi Select									
Multipurpose Seating									
	23 ¹ / ₄ "	24 ³ / ₄ "	34"-39"	19 ¹ / ₂ "	17 ⁷ / ₈ "	18 ³ / ₄ "	15 ¹ / ₂ "-20 ¹ / ₂ "	18"	19 ¹ / ₂ "

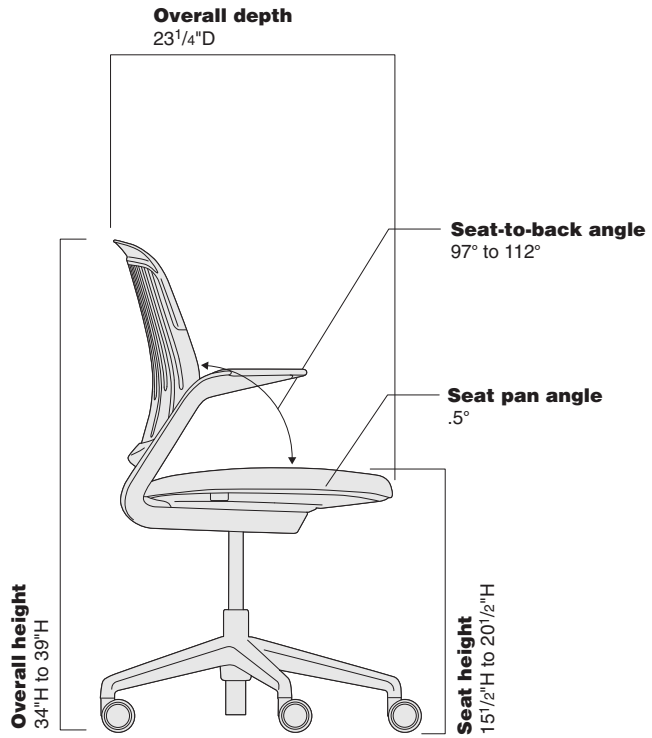
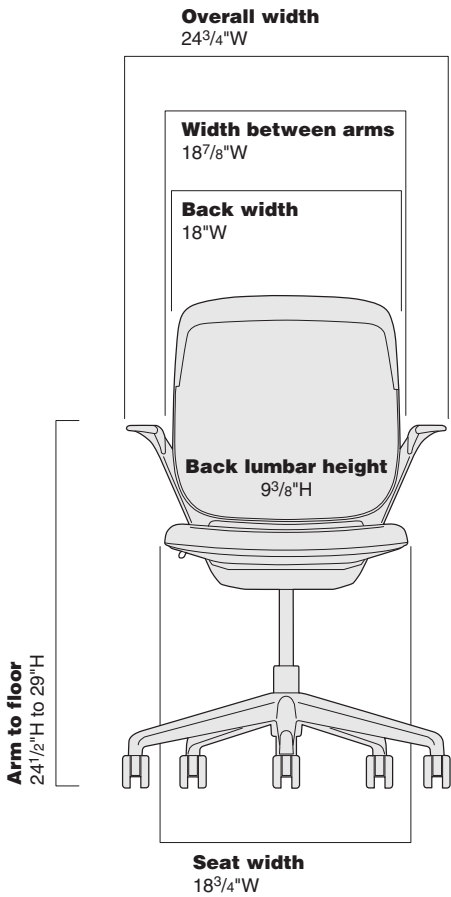

• Back • Lumbar • Height	• Width • Between • Arms	• Arm • to • Floor	• Arm • Height • from • Seat	• Seat • Pan • Angle	• Angle • Between • Seat and • Back
--------------------------------	--------------------------------	--------------------------	---------------------------------------	----------------------------	--

9 ³ / ₈ "	18 ⁷ / ₈ "	24 ¹ / ₄ "–29"	8 ⁷ / ₈ "	.5°	97°–112°
---------------------------------	----------------------------------	--------------------------------------	---------------------------------	-----	----------

cobi Select



Tip: Fire Code Seating (FCS) option is available.
 ▶ Pages 258–259

Tip: Arm caps, top edge, and casters default to coordinate and match outer back color.

Standard Includes		Required to Specify
<ul style="list-style-type: none"> ▶ Need help? Product details, page 146 	<ul style="list-style-type: none"> • Weight-activated mechanism • 5" pneumatic seat-height adjustment • Fixed arms: plastic to match outer back • Back upholstery: Connect 3D • Seat upholstery: Cogent: Connect matches seat upholstery • Frame, outer back, and five-arm base: Near Black • 2½"-diameter, hard composition, dual-wheel casters: black plastic 	<ul style="list-style-type: none"> 1 Style number 2 Connect 3D color number for back 3 Options, if selected (see below) ▶ See <i>Surface Materials</i>, page 196.

	Options	U.S. Price	Required to Specify
Surface Materials	Upholstery		
	<ul style="list-style-type: none"> • Fabric price group 2 • Fire Code Seating (FCS) • Soil-retardant treatment applied to upholstery fabric 	<ul style="list-style-type: none"> No cost +\$41 +\$26 	<ul style="list-style-type: none"> Specify fabric color number. Add suffix F to the style number. Specify with <i>soil-retardant treatment</i>.
	Outer back		
	<ul style="list-style-type: none"> • Near black 	<ul style="list-style-type: none"> No cost 	<ul style="list-style-type: none"> Specify with 6295 <i>Near Black</i>.
Casters	<ul style="list-style-type: none"> • Soft, dual-wheel roll-control casters 	<ul style="list-style-type: none"> +\$26 	<ul style="list-style-type: none"> Specify with <i>soft roll-control casters</i>.
Glides	<ul style="list-style-type: none"> • Glides: plastic 	<ul style="list-style-type: none"> +\$26 	<ul style="list-style-type: none"> Specify with <i>glides</i>.

Specification Information	
Style Number	U.S. Base Price
TS434EXP	\$852

▶ Detailed dimensions, page 148



For Canadian Pricing
 Multiply U.S. Price by the Canadian price factor.
 ▶ See page 1 for details.

Understanding and Specifying Uno Select

Multipurpose Seating

Product Details

Uno Select	152
Dimensions	154

Specifying

Uno Select	155
------------	-----

Uno Select

Uno Select is collaborative seating for teams that helps people move freely, change postures, and stay energized and comfortable.

Arm caps are constructed of a soft durable rubber compound.

Hammock suspension allows the chair to rock gently with your body movement.

Five-arm base is standard.



Seat height adjusts with a 5" range from 15½"H to 20½"H with a pneumatic adjustment mechanism.

Hard, dual-wheel casters are standard for use on carpets. Soft, roll-control, dual-wheel casters are available for use on hard floors or chair mats.

Product Details



Swivel seat allows 360° of rotation.

Adjustment Features

Seat Adjustments

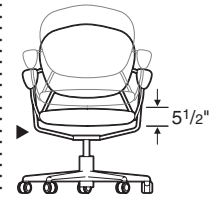

Seat height adjusts pneumatically. To lower, pull lever up while seated. To raise, pull lever up and keep your weight off the chair.

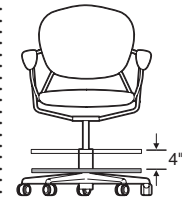

Foot ring height on stools adjusts by rotating it counterclockwise to unlock. Then raise or lower ring up to 5½" to desired position before rotating it clockwise to lock. The foot ring has a diameter of 20".

Surface Materials

▶ See surface materials on page 196 for specific availability or refer to the *Surface Materials Reference Manual* for further information.

Back Upholstery

- Cogent: Connect

Seat Upholstery

- Cogent: Connect

Glides

- Plastic

Foot ring on stools

- 6205 Black

All Steelcase seating with standard upholstery fabrics

complies with requirements of the State of California Technical Bulletin 117. All standard seating is labeled to be in compliance with California 117.

Programs & Services

▶ See the *Surface Materials Reference Manual* for further detail about programs and services offered for seating.

Soil-retardant treatment is available on all other seating fabrics at an additional upcharge per seating unit.

To order this option, please select "Soil-Retardant Treatment" under "Optional Accessories."

For soil-retardant treatment on COMs, please select "Soil-Retardant Treatment" under "Optional Accessories." Minimums or additional yardage may be required. Please contact the vendor directly for specific information.

Extended lead times may be necessary for this service.

Contact your Steelcase Solutions Fulfillment Team Representative at 1.888.STEELCASE (1.888.783.3522) or send an e-mail to lineone@steelcase.com.

Fire Codes

▶ See pages 258–259 for upholstery fabrics available for use with FCS modification.

Steelcase offers Fire Code Seating modification (FCS) on nearly all seating models. The most rigorous fire codes in the nation have been developed in California, and the Steelcase FCS modification is designed to meet those codes. Fire Code Seating (FCS) indicates that a product is constructed to meet the strict fire code requirements of high public occupancy areas such as theaters, meeting rooms, and lobbies. The FCS standards will meet both the State of California Home Furnishing Technical Bulletin 133 (Cal TB 133) and Boston Fire Code (BFC). Boston adopted the California Home Furnishing Technical Bulletin TB 133 test standard in 1992.

Local codes may have special requirements for upholstery.

Dimensions

▶ Page 154

Resources

Printed Materials

▶ Uno Brochure (09-0000049)

Dimensions

Uno Select

Features	Overall Depth	Width	Height	Functional Seat Depth	Seat Width	Seat Height from Floor	Back Width	Back Height from Seat	Width Between Arms	Arm to Floor	Arm Height from Seat
----------	---------------	-------	--------	-----------------------	------------	------------------------	------------	-----------------------	--------------------	--------------	----------------------

Uno Select

Multipurpose Seating

23"	25"	31½"–36½"	19"	18¼"	15½"–20½"	17½"	18"	18½"	23"–28"	7½"
-----	-----	-----------	-----	------	-----------	------	-----	------	---------	-----

Stool Option

23¼"	24¾"	37½"–45"	19"	18¼"	23½"–33¾"	17½"	18"	18½"	31"–41¼"	7½"
------	------	----------	-----	------	-----------	------	-----	------	----------	-----

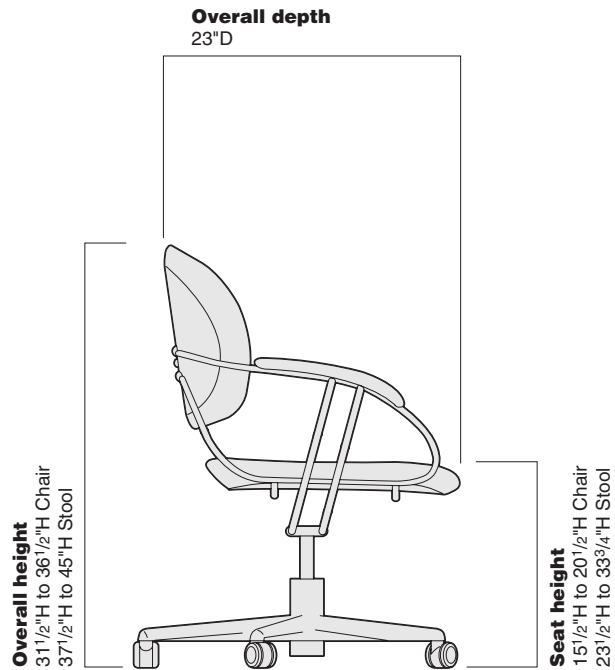
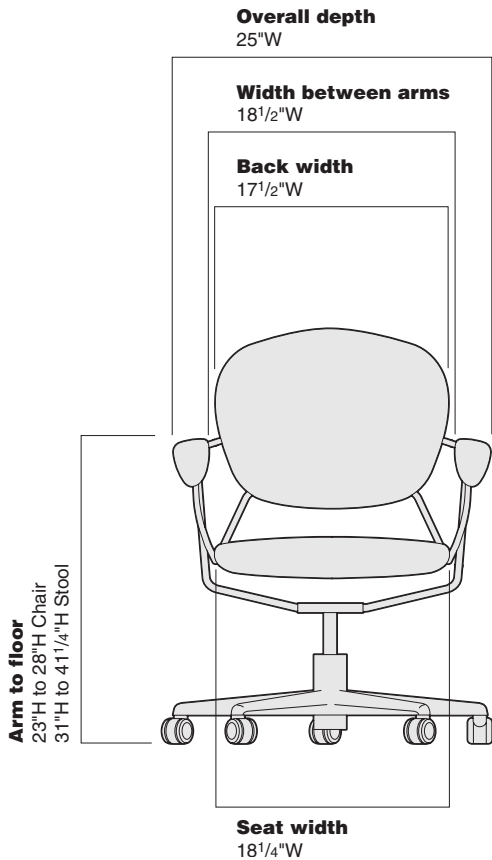

Uno Select



Tip: Frame is available in black only.

Tip: Hard dual-wheel casters are for use on carpet. Use on hard surfaces, including floor mats, will affect chair stability and may result in personal injury.

Standard Includes	Required to Specify
<ul style="list-style-type: none"> Hammock-style support Swivel mechanism Pneumatic height adjustment Upholstered seat and back: fabric price group 2 Outer back: black plastic Five-arm base: reinforced black plastic Hard dual-wheel casters: black Stool ring, if selected: black paint Shipped ready to assemble with no tools required Meets Cal. 116 and 117 requirements 	<ul style="list-style-type: none"> 1 Style number 2 Fabric color number for upholstery 3 Options, if selected (see below) ▶ See <i>Surface Materials</i>, page 196.

Options	U.S. Price	Required to Specify
Surface Materials <ul style="list-style-type: none"> Upholstery fabric Fabric price group 2 Fire Code Seating (FCS) 	<ul style="list-style-type: none"> No cost +\$111 	<ul style="list-style-type: none"> Specify fabric color number. Add suffix F to the style number.
Stool Kit <ul style="list-style-type: none"> Stool kit with swivel mechanism 	<ul style="list-style-type: none"> +\$174 	<ul style="list-style-type: none"> Specify <i>with stool kit</i>.
Casters <ul style="list-style-type: none"> Soft dual-wheel casters for use on hard floors 	<ul style="list-style-type: none"> No cost 	<ul style="list-style-type: none"> Specify <i>with soft casters</i>.
Glides <ul style="list-style-type: none"> Non-marring plastic glides 	<ul style="list-style-type: none"> +\$ 26 	<ul style="list-style-type: none"> Specify <i>with glides</i>.

Specification Information	
<ul style="list-style-type: none"> Style Number 	<ul style="list-style-type: none"> U.S. Base Price

Mid-Back Multi-Purpose Chair

TS311EXP	\$486
.....

▶ Detailed dimensions, page 154



For Canadian Pricing
 Multiply U.S. Price by the Canadian price factor.
 ▶ See page 1 for details.



Understanding and Specifying Scoop

Multipurpose Seating



Product Details

Scoop	158
Dimensions	160



Specifying

Scoop	160
-------	-----

Scoop

Scoop is collaborative seating for teams that helps people move freely, change postures, and stay energized and comfortable.

Durable wire frame is lightweight and available in several finishes.

Glides are standard for use on carpets. Soft glides are available for use on hard floors or chair mats.

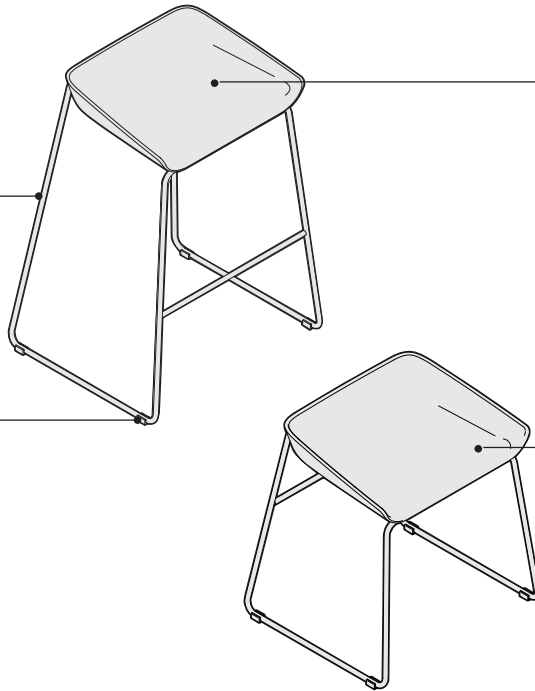

Seat is constructed of molded plastic and available in white or cobblestone.

Upholstered seat is also available.

Product Details

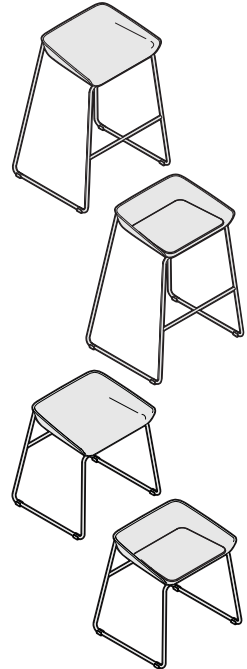

Chairs and stools are available with or without upholstered seat.

Surface Materials

▶ See surface materials on page 196 for specific availability or refer to the *Surface Materials Reference Manual* for further information.

Dimensions

▶ Page 159

Dimensions

Scoop

Features	Overall Depth	Width	Height	Functional Seat Depth	Seat Width	Seat Height from Floor	Foot Bar Height
Scoop							
Side Chairs							
	18 ⁷ / ₈ "	21 ¹ / ₈ "	22 ¹ / ₂ "	13 ¹ / ₂ "	17"	18 ³ / ₈ "	N.A.
Stools							
	22"	23"	33"	13 ¹ / ₂ "	17"	28 ³ / ₄ "	12 ³ / ₄ "

Scoop

Overall width
23"W

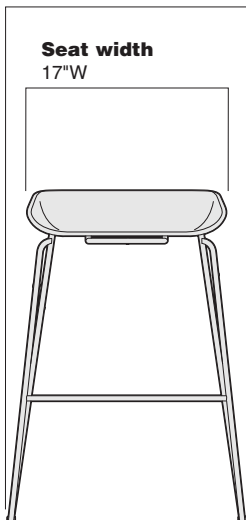

Overall depth
22"D Stool
18⁷/₈"D Side chair

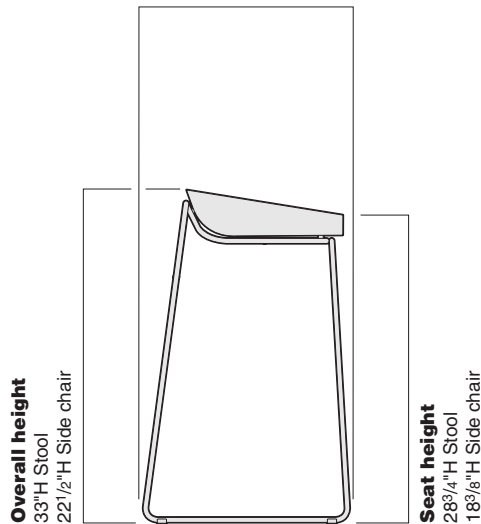

Scoop

Stools

Standard Includes	Required to Specify
<ul style="list-style-type: none"> • Steel wire frame: paint price group 1 • Seat: plastic • Upholstered seat, if selected: fabric price group 1 • Glides • Shipped fully assembled 	<ol style="list-style-type: none"> 1 Style number 2 Paint color number for frame 3 Plastic color number for seat: 6618 White 6682 Cobblestone 4 Fabric color number for upholstery, if selected 5 Options, if selected (see below) <p>▶ See <i>Surface Materials</i>, page 196.</p>

	Options	U.S. Price	Required to Specify
Surface Materials	Steel wire frame		
	<ul style="list-style-type: none"> • Paint price group 1 • Paint price group 2 	No cost +\$22	Specify paint color number. Specify paint color number.
	Upholstery		
	<ul style="list-style-type: none"> • Fabric price group 1 • Fabric price group 2 • Fabric price group 3 • Fabric price group 4 • Fabric price group 5 • Fabric price group 6 • Fabric price group 7 • Fabric price group 8 • Fabric price group 9 • Fabric price group 10 • Customer's Own Material (COM) 	No cost +\$10 +\$22 +\$30 ● +\$37 ● +\$46 ● +\$54 ● +\$68 ● +\$83 ● +\$95 ● +\$16 ●	Specify fabric color number. Specify fabric color number. Specify fabric color number. Specify fabric color number. Specify fabric color number. Specify fabric color number. Specify fabric color number. Specify fabric color number. Specify fabric color number. Specify fabric color number. Specify fabric color number. ▶ See <i>Understanding Customer's Own Material (COM)</i> , page 260.
	Glides		
	<ul style="list-style-type: none"> • Soft glides 	No cost	Specify with soft glides.

Specification Information	
Style Number	U.S. Base Price

Stool	
TS30701	\$312

Stool with Upholstered Seat	
TS30702	\$375

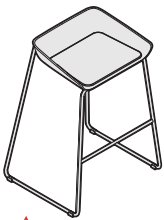
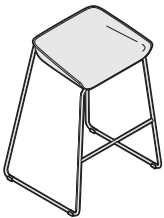

For Canadian Pricing
Multiply U.S. Price by the Canadian price factor.
▶ See page 1 for details.

Side Chairs

Standard Includes		Required to Specify	
<ul style="list-style-type: none"> Steel wire frame: paint price group 1 Seat: plastic Upholstered seat, if selected: fabric price group 1 Glides Shipped fully assembled 		<ol style="list-style-type: none"> Style number Paint color number for frame Plastic color number for seat: 6618 White 6682 Cobblestone Fabric color number for upholstery, if selected Options, if selected (see below) <p>▶ See <i>Surface Materials</i>, page 196.</p>	

Options	U.S. Price	Required to Specify	
Surface Materials			
Steel wire frame			
• Paint price group 1	No cost		Specify paint color number.
• Paint price group 2	+\$22		Specify paint color number.
Upholstery			
• Fabric price group 1	No cost		Specify fabric color number.
• Fabric price group 2	+\$10		Specify fabric color number.
• Fabric price group 3	+\$22		Specify fabric color number.
• Fabric price group 4	+\$30		Specify fabric color number.
• Fabric price group 5	+\$37		Specify fabric color number.
• Fabric price group 6	+\$46		Specify fabric color number.
• Fabric price group 7	+\$54		Specify fabric color number.
• Fabric price group 8	+\$68		Specify fabric color number.
• Fabric price group 9	+\$83		Specify fabric color number.
• Fabric price group 10	+\$95		Specify fabric color number.
• Customer's Own Material (COM)	+\$16		▶ See <i>Understanding Customer's Own Material (COM)</i> , page 260.
Glides			
• Soft glides	No cost		Specify with soft glides.

Specification Information

Style Number	U.S. Base Price
.....

Side Chair

TS30703	\$307
.....

Side Chair with Upholstered Seat

TS30704	\$370
.....

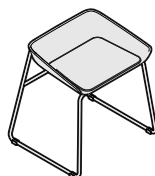
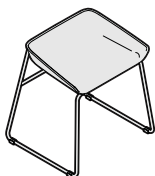
**For Canadian Pricing**

Multiply U.S. Price by the Canadian price factor.

▶ See page 1 for details.



Understanding and Specifying Jenny Lounge Lounge Seating



Product Details

Dimensions **164**



Specifying

Jenny Lounge **166**

Dimensions

Jenny Lounge

Features	Overall Depth	Width	Height	Functional Seat Depth	Seat Width	Seat Height from Floor	Back Width	Back Height from Seat	Width Between Arms
Jenny Lounge									
Lounge Seating									
Armless	32 ¹ / ₂ "	28 ¹ / ₂ "	32 ¹ / ₄ "	21"	28 ¹ / ₂ "	16", compressed	28 ¹ / ₂ "	18"	N.A.
Both Arms	32 ¹ / ₂ "	34 ¹ / ₂ "	32 ¹ / ₄ "	21"	19 ³ / ₄ "	16", compressed	28 ¹ / ₂ "	18"	26"
Right arm or Left arm only	32 ¹ / ₂ "	31 ¹ / ₂ "	32 ¹ / ₄ "	21"	23 ¹ / ₂ "	16", compressed	28 ¹ / ₂ "	18"	N.A.
Corner	32"	32"	32"	20"	20"	N.A.	N.A.	18"	N.A.
Club	31 ³ / ₄ "	31 ³ / ₄ "	31 ³ / ₄ "	21"	19"	16", compressed	28"	16"	19 ¹ / ₂ "
Round	31 ³ / ₄ "	31 ³ / ₄ "	31 ³ / ₄ "	21"	19"	16", compressed	28 ¹ / ₂ "	18"	25 ³ / ₄ "
Wood Arms	32 ¹ / ₂ "	32 ¹ / ₂ "	32 ¹ / ₂ "	21"	24"	16", compressed	24"	16"	24 ¹ / ₄ "
Ottoman	27 ¹ / ₂ "	28 ¹ / ₂ "	18"	N.A.	N.A.	N.A.	N.A.	N.A.	N.A.

• Arm Rest Width	• Arm Rest Length	• Arm Height to Floor	• Arm Height from Seat	• Tablet Width	• Tablet Length	• Tablet Height to Floor	• Tablet Height from Seat
N.A.	N.A.	N.A.	N.A.	9"	16"	24 ^{1/2} "	6 ^{3/4} "
4"	19 ^{3/4} "	26"	9 ^{1/2} "	N.A.	N.A.	N.A.	N.A.
4"	19 ^{3/4} "	26"	9 ^{1/2} "	9"	16"	24 ^{1/2} "	6 ^{3/4} "
N.A.	N.A.	N.A.	N.A.	N.A.	N.A.	N.A.	N.A.
4 ^{1/2} "	19 ^{3/4} "	26"	7 ^{3/4} "	N.A.	N.A.	N.A.	N.A.
4"	N.A.	26"	9 ^{1/2} "	N.A.	N.A.	N.A.	N.A.
3 ^{1/2} "	24"	26"	9"	N.A.	N.A.	N.A.	N.A.
N.A.	N.A.	N.A.	N.A.	N.A.	N.A.	N.A.	N.A.

► Options, continued from previous page

Options	U.S. Price	Required to Specify
Surface Materials (continued)		
② Fabric on inner back		
• Fabric price group 1	No cost	Specify fabric color number.
• Fabric price group 2	+\$ 8	Specify fabric color number.
• Fabric price group 3	+\$ 20	Specify fabric color number.
• Fabric price group 4	+\$ 27	Specify fabric color number.
• Fabric price group 5	+\$ 35	Specify fabric color number.
• Fabric price group 6	+\$ 43	Specify fabric color number.
• Fabric price group 7	+\$ 51	Specify fabric color number.
• Fabric price group 8	+\$ 64	Specify fabric color number.
• Fabric price group 9	+\$ 80	Specify fabric color number.
• Fabric price group 10	+\$ 92	Specify fabric color number.
• Leather price group	+\$401	Specify fabric color number. Add suffix L to style number and specify leather color number.
• Customer's Own Material (COM)	+\$ 16	► See <i>Understanding Customer's Own Material (COM)</i> , page 260.
• Customer's Own Leather (COL)	+\$ 16	Add suffix L to style number and specify leather color number.
③ Fabric on outer back		
• Fabric price group 1	No cost	Specify fabric color number.
• Fabric price group 2	+\$ 6	Specify fabric color number.
• Fabric price group 3	+\$ 14	Specify fabric color number.
• Fabric price group 4	+\$ 21	Specify fabric color number.
• Fabric price group 5	+\$ 26	Specify fabric color number.
• Fabric price group 6	+\$ 32	Specify fabric color number.
• Fabric price group 7	+\$ 38	Specify fabric color number.
• Fabric price group 8	+\$ 48	Specify fabric color number.
• Fabric price group 9	+\$ 60	Specify fabric color number.
• Fabric price group 10	+\$ 69	Specify fabric color number.
• Leather price group	+\$557	Specify fabric color number. Add suffix L to style number and specify leather color number.
• Customer's Own Material (COM)	+\$ 16	► See <i>Understanding Customer's Own Material (COM)</i> , page 260.
• Customer's Own Leather (COL)	+\$ 16	Add suffix L to style number and specify leather color number.
Legs		
• Brushed Aluminum legs	+\$100	Specify with <i>Brushed Aluminum legs</i> .
• Solid maple wood legs	+\$133	Specify with <i>solid maple wood legs</i> and select 3412 Natural Cherry, 3522 Clear Maple, or 3762 Dark Walnut.

Related Products

• Ganging kit

► Page 183

Specification Information

Style Number	U.S. Base Price	Style Number	U.S. Base Price	Style Number	U.S. Base Price	Style Number	U.S. Base Price
LPL	Price	HPL	Price	LPL	Price	HPL	Price



Glides



Casters

With Glides

TS31401 \$1022

With Two Casters and Two Glides

TS31401C \$1064



Glides



Casters

With Tablet Arm (180° Pivot)

TS31401T \$1268 **TS31401H** \$1300

With Tablet Arm (180° Pivot)

TS31401CT \$1310 **TS31401CH** \$1342

Jenny Lounge, continued

With Arms

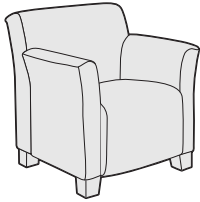

Tip: Tablet arm is only available on armless and one arm versions of Jenny.

Tip: Jenny lounge products have a relaxed appearance. They may show soft comfort wrinkles upon use.

Tip: Hard dual-wheel casters are for use on carpet. Use on hard surfaces, including floor mats, will affect chair stability and may result in personal injury.

Tip: Leather price group option ships at extended lead times.

Tip: Jenny lounge chairs are available with multiple fabrics.

▶ See at right to specify.

Tip: When specifying multiple fabrics and Fire Code Seating, specify suffix **F** at the end of the style number. Example: TS31401MF

Tip: When specifying multiple COM fabrics, indicate all surfaces where COM applies. Example: TS31402M with Designtex 1234 on seat, Designtex 5678 on inner back, Designtex 9012 on outer back, and Designtex 9012 on arms.

Tip: When specifying multiple fabrics and leather, specify suffix **M** before suffix **L**. Example: TS31401ML
TS31401CML

Standard Includes	Required to Specify
-------------------	---------------------

- | | |
|--|---|
| Standard Includes | Required to Specify |
| <ul style="list-style-type: none"> Fully upholstered lounge chair with arms: fabric price group 1 Hard dual-wheel casters or legs with glides: black plastic Shipped fully assembled Meets Cal. 116 and 117 requirements | <ul style="list-style-type: none"> 1 Style number 2 Fabric color number for upholstery 3 Options, if selected (see below) ▶ See <i>Surface Materials</i>, page 196. |

Surface Materials	Options	U.S. Price	Required to Specify
-------------------	---------	------------	---------------------

Surface Materials	Options	U.S. Price	Required to Specify
	Single upholstery fabric		
	<ul style="list-style-type: none"> Fabric price group 1 Fabric price group 2 Fabric price group 3 Fabric price group 4 Fabric price group 5 Fabric price group 6 Fabric price group 7 Fabric price group 8 Fabric price group 9 Fabric price group 10 Leather price group 	<ul style="list-style-type: none"> No cost +\$ 41 +\$ 95 +\$ 134 +\$ 175 +\$ 214 +\$ 255 +\$ 321 +\$ 401 +\$ 456 +\$2775 	<ul style="list-style-type: none"> Specify fabric color number. Specify fabric color number. Specify fabric color number. Specify fabric color number. Specify fabric color number. Specify fabric color number. Specify fabric color number. Specify fabric color number. Specify fabric color number. Specify fabric color number. Specify fabric color number. Specify fabric color number. Add suffix L to style number and specify leather color number. ▶ See <i>Understanding Customer's Own Material (COM)</i>, page 260. Add suffix L to style number and specify leather color number. Add suffix F to style number and specify fabric color number.
	<ul style="list-style-type: none"> Customer's Own Material (COM) Customer's Own Leather (COL) Fire Code Seating (FCS) 	<ul style="list-style-type: none"> +\$ 32 +\$ 32 +\$ 416 	
	Multiple upholstery fabrics		
	<ul style="list-style-type: none"> Two or more fabrics on different chair components ▶ See below and at right. 	<ul style="list-style-type: none"> +\$ 57 	<ul style="list-style-type: none"> Add suffix M to lounge chair style number and select fabric color number for: 1 Seat 2 Inner back 3 Outer back 4 Arms Example: TS31402M with T015 on seat, T016 on inner back, T017 on outer back, and T018 on arms. Add suffix F to style number and specify fabric color number.
	<ul style="list-style-type: none"> Fire Code Seating (FCS) 	<ul style="list-style-type: none"> +\$ 416 	
	1 Fabric on seat		
	<ul style="list-style-type: none"> Fabric price group 1 Fabric price group 2 Fabric price group 3 Fabric price group 4 Fabric price group 5 Fabric price group 6 Fabric price group 7 Fabric price group 8 Fabric price group 9 Fabric price group 10 Leather price group 	<ul style="list-style-type: none"> No cost +\$ 11 +\$ 28 +\$ 38 +\$ 50 +\$ 62 +\$ 74 +\$ 94 +\$ 116 +\$ 132 +\$ 792 	<ul style="list-style-type: none"> Specify fabric color number. Specify fabric color number. Specify fabric color number. Specify fabric color number. Specify fabric color number. Specify fabric color number. Specify fabric color number. Specify fabric color number. Specify fabric color number. Specify fabric color number. Specify fabric color number. Specify fabric color number. Add suffix L to style number and specify leather color number. ▶ See <i>Understanding Customer's Own Material (COM)</i>, page 260. Add suffix L to style number and specify leather color number.
	<ul style="list-style-type: none"> Customer's Own Material (COM) Customer's Own Leather (COL) 	<ul style="list-style-type: none"> +\$ 16 +\$ 16 	

▶ Options, continued on next page



For Canadian Pricing

Multiply U.S. Price by the Canadian price factor.

▶ See page 1 for details.

► Options, continued from previous page

Options	U.S. Price	Required to Specify
Surface Materials (continued)		
2 Fabric on inner back		
• Fabric price group 1	No cost	Specify fabric color number.
• Fabric price group 2	+\$ 8	Specify fabric color number.
• Fabric price group 3	+\$ 20	Specify fabric color number.
• Fabric price group 4	+\$ 27	Specify fabric color number.
• Fabric price group 5	+\$ 35	Specify fabric color number.
• Fabric price group 6	+\$ 43	Specify fabric color number.
• Fabric price group 7	+\$ 51	Specify fabric color number.
• Fabric price group 8	+\$ 64	Specify fabric color number.
• Fabric price group 9	+\$ 80	Specify fabric color number.
• Fabric price group 10	+\$ 92	Specify fabric color number.
• Leather price group	+\$ 401	Specify fabric color number. Add suffix L to style number and specify leather color number.
• Customer's Own Material (COM)	+\$ 16	► See <i>Understanding Customer's Own Material (COM)</i> , page 260.
• Customer's Own Leather (COL)	+\$ 16	Add suffix L to style number and specify leather color number.
3 Fabric on outer back		
• Fabric price group 1	No cost	Specify fabric color number.
• Fabric price group 2	+\$ 6	Specify fabric color number.
• Fabric price group 3	+\$ 14	Specify fabric color number.
• Fabric price group 4	+\$ 21	Specify fabric color number.
• Fabric price group 5	+\$ 26	Specify fabric color number.
• Fabric price group 6	+\$ 32	Specify fabric color number.
• Fabric price group 7	+\$ 38	Specify fabric color number.
• Fabric price group 8	+\$ 48	Specify fabric color number.
• Fabric price group 9	+\$ 60	Specify fabric color number.
• Fabric price group 10	+\$ 69	Specify fabric color number.
• Leather price group	+\$ 557	Specify fabric color number. Add suffix L to style number and specify leather color number.
• Customer's Own Material (COM)	+\$ 16	► See <i>Understanding Customer's Own Material (COM)</i> , page 260.
• Customer's Own Leather (COL)	+\$ 16	Add suffix L to style number and specify leather color number.
4 Fabric on arms		
• Fabric price group 1	No cost	Specify fabric color number.
• Fabric price group 2	+\$ 15	Specify fabric color number.
• Fabric price group 3	+\$ 34	Specify fabric color number.
• Fabric price group 4	+\$ 48	Specify fabric color number.
• Fabric price group 5	+\$ 63	Specify fabric color number.
• Fabric price group 6	+\$ 77	Specify fabric color number.
• Fabric price group 7	+\$ 93	Specify fabric color number.
• Fabric price group 8	+\$ 115	Specify fabric color number.
• Fabric price group 9	+\$ 145	Specify fabric color number.
• Fabric price group 10	+\$ 164	Specify fabric color number.
• Leather price group	+\$1061	Specify fabric color number. Add suffix L to style number and specify leather color number.
• Customer's Own Material (COM)	+\$ 16	► See <i>Understanding Customer's Own Material (COM)</i> , page 260.
• Customer's Own Leather (COL)	+\$ 16	Add suffix L to style number and specify leather color number.
Legs		
• Brushed Aluminum legs	+\$ 100	Specify with <i>Brushed Aluminum legs</i> .
• Solid maple wood legs	+\$ 133	Specify with <i>solid maple wood legs</i> and select 3412 Natural Cherry, 3522 Clear Maple, or 3762 Dark Walnut.

Jenny Lounge

Tip: Brushed Aluminum legs are adjustable and have 3/4" of height adjustment.

Specification Information

Style Number	U.S. Base Price	Style Number	U.S. Base Price
--------------	-----------------	--------------	-----------------

With Glides

TS31402	\$1144
---------	--------

With Two Casters and Two Glides

TS31402C	\$1186
----------	--------



Glides



Casters

Jenny Lounge, continued

With Arm Left or Right

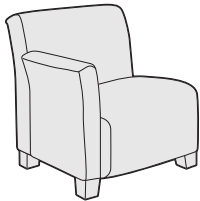

Tip: Tablet arm is only available on armless and one arm versions of Jenny.

Tip: Jenny lounge products have a relaxed appearance. They may show soft comfort wrinkles upon use.

Tip: Hard dual-wheel casters are for use on carpet. Use on hard surfaces, including floor mats, will affect chair stability and may result in personal injury.

Tip: There may be sheen or texture differences when using LPL and HPL in adjacent applications. Please use caution when mixing and matching different worksurface types.

Tip: Leather price group option ships at extended lead times.

Tip: Jenny lounge chairs are available with multiple fabrics.
▶ See at right to specify.

Tip: When specifying multiple fabrics and Fire Code Seating, specify suffix **F** at the end of the style number.
Example: TS31401MF

Tip: When specifying multiple COM fabrics, indicate all surfaces where COM applies.
Example: TS31403M with Designtex 1234 on seat, Designtex 5678 on inner back, Designtex 9012 on outer back, and Designtex 9012 on arm.

Tip: When specifying multiple fabrics and leather, specify suffix **M** before suffix **L**.
Example: TS31401ML
TS31401CML

Standard Includes	Required to Specify
-------------------	---------------------

- | | |
|--|---|
| <ul style="list-style-type: none"> Fully upholstered lounge chair with arm left or right: fabric price group 1 Tablet arm, if selected: Low-Pressure Laminate (LPL), or High-Pressure Laminate (HPL) 3 mm edge band for tablet arm, if selected: plastic Hard dual-wheel casters or legs with glides: black plastic Shipped fully assembled Exception: Tablet arm is shipped ready to assemble. Meets Cal. 116 and 117 requirements | <ol style="list-style-type: none"> Style number Fabric color number for upholstery Low-Pressure Laminate or High-Pressure Laminate color number for tablet arm, if selected Plastic edge band color number for tablet arm, if selected Options, if selected (see below) <p>▶ See <i>Surface Materials</i>, page 196.</p> |
|--|---|

Options	U.S. Price	Required to Specify
---------	------------	---------------------

Surface Materials	Single upholstery fabric	
	<ul style="list-style-type: none"> Fabric price group 1 No cost Fabric price group 2 +\$ 33 Fabric price group 3 +\$ 77 Fabric price group 4 +\$ 110 Fabric price group 5 +\$ 144 Fabric price group 6 +\$ 176 Fabric price group 7 +\$ 209 Fabric price group 8 +\$ 263 Fabric price group 9 +\$ 330 Fabric price group 10 +\$ 373 Leather price group +\$2309 	Specify fabric color number. Specify fabric color number. Specify fabric color number. Specify fabric color number. Specify fabric color number. Specify fabric color number. Specify fabric color number. Specify fabric color number. Specify fabric color number. Specify fabric color number. Add suffix L to style number and specify leather color number. ▶ See <i>Understanding Customer's Own Material (COM)</i> , page 260. Add suffix L to style number and specify leather color number. Add suffix F to style number and specify fabric color number.
	<ul style="list-style-type: none"> Customer's Own Material (COM) +\$ 32 Customer's Own Leather (COL) +\$ 32 Fire Code Seating (FCS) +\$ 364 	

Multiple upholstery fabrics

- | | |
|---|--|
| <ul style="list-style-type: none"> Two or more fabrics on different chair components +\$ 57 <p>▶ See below and at right.</p> | Add suffix M to lounge chair style number and select fabric color number for: <ol style="list-style-type: none"> Seat Inner back Outer back Arm <p>Example: TS31403M with T015 on seat, T016 on inner back, T017 on outer back, and T018 on arm.</p> Add suffix F to style number and specify fabric color number. |
| <ul style="list-style-type: none"> Fire Code Seating (FCS) +\$ 364 | |

1 Fabric on seat

- | | |
|---|--|
| <ul style="list-style-type: none"> Fabric price group 1 No cost Fabric price group 2 +\$ 11 Fabric price group 3 +\$ 28 Fabric price group 4 +\$ 38 Fabric price group 5 +\$ 50 Fabric price group 6 +\$ 62 Fabric price group 7 +\$ 74 Fabric price group 8 +\$ 94 Fabric price group 9 +\$ 116 Fabric price group 10 +\$ 132 Leather price group +\$ 857 | Specify fabric color number.
Specify fabric color number.
Specify fabric color number.
Specify fabric color number.
Specify fabric color number.
Specify fabric color number.
Specify fabric color number.
Specify fabric color number.
Specify fabric color number.
Specify fabric color number.
Add suffix L to style number and specify leather color number.
▶ See <i>Understanding Customer's Own Material (COM)</i> , page 260.
Add suffix L to style number and specify leather color number. |
| <ul style="list-style-type: none"> Customer's Own Material (COM) +\$ 16 Customer's Own Leather (COL) +\$ 16 | |

▶ Options, continued on next page

► Options, continued from previous page

	Options	U.S. Price	Required to Specify
Surface Materials (continued)	2 Fabric on inner back		
	• Fabric price group 1	No cost	Specify fabric color number.
	• Fabric price group 2	+\$ 8	Specify fabric color number.
	• Fabric price group 3	+\$ 20	Specify fabric color number.
	• Fabric price group 4	+\$ 27	Specify fabric color number.
	• Fabric price group 5	+\$ 35	Specify fabric color number.
	• Fabric price group 6	+\$ 43	Specify fabric color number.
	• Fabric price group 7	+\$ 51	Specify fabric color number.
	• Fabric price group 8	+\$ 64	Specify fabric color number.
	• Fabric price group 9	+\$ 80	Specify fabric color number.
	• Fabric price group 10	+\$ 92	Specify fabric color number.
	• Leather price group	+\$401	Add suffix L to style number and specify leather color number.
	• Customer's Own Material (COM)	+\$ 16	► See <i>Understanding Customer's Own Material (COM)</i> , page 260.
	• Customer's Own Leather (COL)	+\$ 16	Add suffix L to style number and specify leather color number.
	3 Fabric on outer back		
	• Fabric price group 1	No cost	Specify fabric color number.
	• Fabric price group 2	+\$ 6	Specify fabric color number.
	• Fabric price group 3	+\$ 14	Specify fabric color number.
	• Fabric price group 4	+\$ 21	Specify fabric color number.
	• Fabric price group 5	+\$ 26	Specify fabric color number.
• Fabric price group 6	+\$ 32	Specify fabric color number.	
• Fabric price group 7	+\$ 38	Specify fabric color number.	
• Fabric price group 8	+\$ 48	Specify fabric color number.	
• Fabric price group 9	+\$ 60	Specify fabric color number.	
• Fabric price group 10	+\$ 69	Specify fabric color number.	
• Leather price group	+\$557	Add suffix L to style number and specify leather color number.	
• Customer's Own Material (COM)	+\$ 16	► See <i>Understanding Customer's Own Material (COM)</i> , page 260.	
• Customer's Own Leather (COL)	+\$ 16	Add suffix L to style number and specify leather color number.	
4 Fabric on arm			
• Fabric price group 1	No cost	Specify fabric color number.	
• Fabric price group 2	+\$ 7	Specify fabric color number.	
• Fabric price group 3	+\$ 19	Specify fabric color number.	
• Fabric price group 4	+\$ 26	Specify fabric color number.	
• Fabric price group 5	+\$ 33	Specify fabric color number.	
• Fabric price group 6	+\$ 41	Specify fabric color number.	
• Fabric price group 7	+\$ 48	Specify fabric color number.	
• Fabric price group 8	+\$ 61	Specify fabric color number.	
• Fabric price group 9	+\$ 76	Specify fabric color number.	
• Fabric price group 10	+\$ 85	Specify fabric color number.	
• Leather price group	+\$530	Add suffix L to style number and specify leather color number.	
• Customer's Own Material (COM)	+\$ 16	► See <i>Understanding Customer's Own Material (COM)</i> , page 260.	
• Customer's Own Leather (COL)	+\$ 16	Add suffix L to style number and specify leather color number.	
	High-Pressure Laminate tablet		
	• Open Line laminate	+\$ 64 plus cost of laminate	► See <i>Surface Materials Reference Manual</i> .
	Legs		
	• Brushed Aluminum legs	+\$100	Specify with <i>Brushed Aluminum legs</i> .
	• Solid maple wood legs	+\$133	Specify with <i>solid maple wood legs</i> and select 3412 Natural Cherry, 3522 Clear Maple, or 3762 Dark Walnut.
Related Products	• Ganging kit		► Page 183

Tip: Brushed Aluminum legs are adjustable and have 3/4" of height adjustment.

**For Canadian Pricing**

Multiply U.S. Price by the Canadian price factor.

► See page 1 for details.

► Specification Information, on next page

Jenny Lounge, continued

► Options, on previous page

Specification Information

Style Number LPL	U.S. Base Price	Style Number HPL	U.S. Base Price
------------------	-----------------	------------------	-----------------

Style Number LPL	U.S. Base Price	Style Number HPL	U.S. Base Price
------------------	-----------------	------------------	-----------------

With Glides

Arm Right

TS31403	\$1082
----------------	--------

With Two Casters and Two Glides

Arm Right

TS31403C	\$1124
-----------------	--------

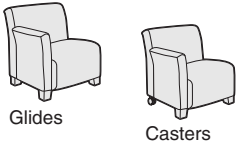

Tip: Casters and tablet arm are not retrofittable on style number TS31403.

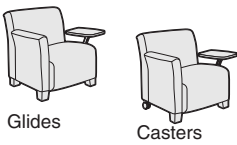

Arm Right with Tablet Arm

TS31403T	\$1328	TS31403H	\$1360
-----------------	--------	-----------------	--------

Arm Right with Tablet Arm

TS31403CT	\$1370	TS31403CH	\$1402
------------------	--------	------------------	--------

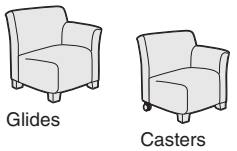

Tip: Casters and tablet arm are not retrofittable on style number TS31404.

Arm Left

TS31404	\$1082
----------------	--------

Arm Left

TS31404C	\$1124
-----------------	--------

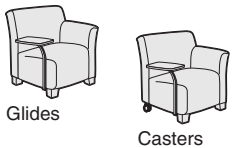

Arm Left with Tablet Arm with 180°Swivel

TS31404T	\$1328	TS31404H	\$1360
-----------------	--------	-----------------	--------

Arm Left with Tablet Arm with 180°Swivel

TS31404CT	\$1370	TS31404CH	\$1402
------------------	--------	------------------	--------



For Canadian Pricing

Multiply U.S. Price by the Canadian price factor.

► See page 1 for details.

Jenny Lounge, continued

Corner

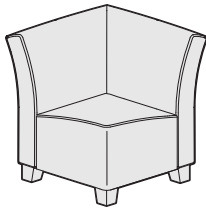

Tip: Tablet arm is only available on armless and one arm versions of Jenny.

Tip: Jenny lounge products have a relaxed appearance. They may show soft comfort wrinkles upon use.

Tip: Hard dual-wheel casters are for use on carpet. Use on hard surfaces, including floor mats, will affect chair stability and may result in personal injury.

Tip: Leather price group option ships at extended lead times.

Tip: Jenny lounge chairs are available with multiple fabrics.

▶ See at right to specify.

Tip: When specifying multiple fabrics and Fire Code Seating, specify suffix **F** at the end of the style number. Example: TS31401MF

Tip: When specifying multiple COM fabrics, indicate all surfaces where COM applies. Example: TS31406M with Designtex 1234 on seat, Designtex 5678 on inner back, and Designtex 9012 on outer back.

Tip: When specifying multiple fabrics and leather, specify suffix **M** before suffix **L**. Example: TS31406ML TS31406CML

Standard Includes	Required to Specify
<ul style="list-style-type: none"> Fully upholstered lounge chair: fabric price group 1 Hard dual-wheel casters or legs with glides: black plastic Shipped fully assembled Meets Cal. 116 and 117 requirements 	<ul style="list-style-type: none"> 1 Style number 2 Fabric color number for upholstery 3 Options, if selected (see below) ▶ See <i>Surface Materials</i>, page 196.

Surface Materials	Options	U.S. Price	Required to Specify
	Single upholstery fabric		
	<ul style="list-style-type: none"> Fabric price group 1 Fabric price group 2 Fabric price group 3 Fabric price group 4 Fabric price group 5 Fabric price group 6 Fabric price group 7 Fabric price group 8 Fabric price group 9 Fabric price group 10 Leather price group 	<ul style="list-style-type: none"> No cost +\$ 26 +\$ 60 +\$ 85 +\$ 111 +\$ 137 +\$ 163 +\$ 206 +\$ 257 +\$ 291 +\$1794 	<ul style="list-style-type: none"> Specify fabric color number. Specify fabric color number. Specify fabric color number. Specify fabric color number. Specify fabric color number. Specify fabric color number. Specify fabric color number. Specify fabric color number. Specify fabric color number. Specify fabric color number. Specify fabric color number. Add suffix L to style number and specify leather color number. ▶ See <i>Understanding Customer's Own Material (COM)</i>, page 260. Add suffix L to style number and specify leather color number. Add suffix F to style number and specify fabric color number.
	<ul style="list-style-type: none"> Customer's Own Material (COM) Customer's Own Leather (COL) Fire Code Seating (FCS) 	<ul style="list-style-type: none"> +\$ 32 +\$ 32 +\$ 494 	

	Multiple upholstery fabrics		
	<ul style="list-style-type: none"> Two or more fabrics on different chair components 	<ul style="list-style-type: none"> +\$ 57 	<ul style="list-style-type: none"> Add suffix M to lounge chair style number and select fabric color number for:
	▶ See below and at right.		<ul style="list-style-type: none"> 1 Seat 2 Inner back 3 Outer back
	<ul style="list-style-type: none"> Fire Code Seating (FCS) 	<ul style="list-style-type: none"> +\$ 494 	<ul style="list-style-type: none"> Example: TS31406M with T015 on seat, T016 on inner back, and T017 on outer back. Add suffix F to style number and specify fabric color number.
	1 Fabric on seat		
	<ul style="list-style-type: none"> Fabric price group 1 Fabric price group 2 Fabric price group 3 Fabric price group 4 Fabric price group 5 Fabric price group 6 Fabric price group 7 Fabric price group 8 Fabric price group 9 Fabric price group 10 Leather price group 	<ul style="list-style-type: none"> No cost +\$ 11 +\$ 28 +\$ 38 +\$ 50 +\$ 62 +\$ 74 +\$ 94 +\$ 116 +\$ 132 +\$ 873 	<ul style="list-style-type: none"> Specify fabric color number. Specify fabric color number. Specify fabric color number. Specify fabric color number. Specify fabric color number. Specify fabric color number. Specify fabric color number. Specify fabric color number. Specify fabric color number. Specify fabric color number. Specify fabric color number. Add suffix L to style number and specify leather color number. ▶ See <i>Understanding Customer's Own Material (COM)</i>, page 260. Add suffix L to style number and specify leather color number.
	<ul style="list-style-type: none"> Customer's Own Material (COM) Customer's Own Leather (COL) 	<ul style="list-style-type: none"> +\$ 16 +\$ 16 	

▶ Options, continued on next page



For Canadian Pricing

Multiply U.S. Price by the Canadian price factor.

▶ See page 1 for details.

► Options, continued from previous page

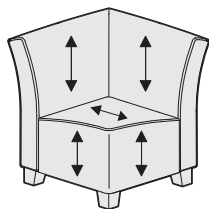

Tip: Standard seat fabric directionality is applied as the diagram above indicates (ex. TS31406).

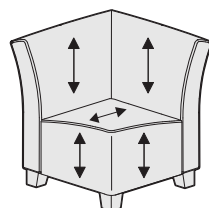

Tip: Reverse seat fabric directionality is applied as the diagram above indicates (ex. TS31426).

Tip: Brushed Aluminum legs are adjustable and have 3/4" of height adjustment.

Options	U.S. Price	Required to Specify
Surface Materials (continued)		
② Fabric on inner back		
• Fabric price group 1	No cost	Specify fabric color number.
• Fabric price group 2	+\$ 8	Specify fabric color number.
• Fabric price group 3	+\$ 20	Specify fabric color number.
• Fabric price group 4	+\$ 27	Specify fabric color number.
• Fabric price group 5	+\$ 35	Specify fabric color number.
• Fabric price group 6	+\$ 43	Specify fabric color number.
• Fabric price group 7	+\$ 51	Specify fabric color number.
• Fabric price group 8	+\$ 64	Specify fabric color number.
• Fabric price group 9	+\$ 80	Specify fabric color number.
• Fabric price group 10	+\$ 92	Specify fabric color number.
• Leather price group	+\$401	Specify fabric color number. Add suffix L to style number and specify leather color number.
• Customer's Own Material (COM)	+\$ 16	► See <i>Understanding Customer's Own Material (COM)</i> , page 260.
• Customer's Own Leather (COL)	+\$ 16	Add suffix L to style number and specify leather color number.
③ Fabric on outer back		
• Fabric price group 1	No cost	Specify fabric color number.
• Fabric price group 2	+\$ 6	Specify fabric color number.
• Fabric price group 3	+\$ 14	Specify fabric color number.
• Fabric price group 4	+\$ 21	Specify fabric color number.
• Fabric price group 5	+\$ 26	Specify fabric color number.
• Fabric price group 6	+\$ 32	Specify fabric color number.
• Fabric price group 7	+\$ 38	Specify fabric color number.
• Fabric price group 8	+\$ 48	Specify fabric color number.
• Fabric price group 9	+\$ 60	Specify fabric color number.
• Fabric price group 10	+\$ 69	Specify fabric color number.
• Leather price group	+\$557	Specify fabric color number. Add suffix L to style number and specify leather color number.
• Customer's Own Material (COM)	+\$ 16	► See <i>Understanding Customer's Own Material (COM)</i> , page 260.
• Customer's Own Leather (COL)	+\$ 16	Add suffix L to style number and specify leather color number.
Legs		
• Brushed Aluminum legs	+\$100	Specify with <i>Brushed Aluminum legs</i> .
• Solid maple wood legs	+\$133	Specify with <i>solid maple wood legs</i> and select 3412 Natural Cherry, 3522 Clear Maple, or 3762 Dark Walnut.

Related Products • Ganging kit ► Page 183

Specification Information

Style Number	U.S. Base Price	Style Number	U.S. Base Price

Standard Seat Fabric Directionality

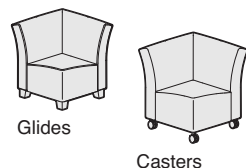

With Glides		With Casters	
TS31406	\$1084	TS31406C	\$1126

Reverse Seat Fabric Directionality

With Glides		With Casters	
TS31426	\$1084	TS31426C	\$1126

For Canadian Pricing
Multiply U.S. Price by the Canadian price factor.
► See page 1 for details.

Jenny Lounge, continued

Club

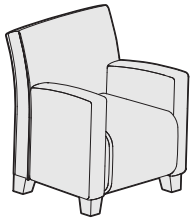

Tip: Tablet arm is only available on armless and one arm versions of Jenny.

Tip: Jenny lounge products have a relaxed appearance. They may show soft comfort wrinkles upon use.

Tip: Hard dual-wheel casters are for use on carpet. Use on hard surfaces, including floor mats, will affect chair stability and may result in personal injury.

Tip: Leather price group option ships at extended lead times.

Tip: Jenny lounge chairs are available with multiple fabrics.

▶ See at right to specify.

Tip: When specifying multiple fabrics and Fire Code Seating, specify suffix **F** at the end of the style number. Example: TS31401MF

Tip: When specifying multiple COM fabrics, indicate all surfaces where COM applies. Example: TS31407M with Designtex 1234 on seat, Designtex 5678 on inner back, Designtex 9012 on outer back, and Designtex 9012 on arms.

Tip: When specifying multiple fabrics and leather, specify suffix **M** before suffix **L**. Example: TS31407ML TS31407CML

Standard Includes	Required to Specify
-------------------	---------------------

- | | |
|--|---|
| <ul style="list-style-type: none"> Fully upholstered lounge chair with arms: fabric price group 1 Deck stitch detail Hard dual-wheel casters or legs with glides: black plastic Shipped fully assembled Meets Cal. 116 and 117 requirements | <ul style="list-style-type: none"> 1 Style number 2 Fabric color number for upholstery 3 Options, if selected (see below) ▶ See <i>Surface Materials</i>, page 196. |
|--|---|

Options	U.S. Price	Required to Specify
---------	------------	---------------------

Surface Materials

Single upholstery fabric

- | | |
|---------------------------------|---------|
| • Fabric price group 1 | No cost |
| • Fabric price group 2 | +\$ 41 |
| • Fabric price group 3 | +\$ 95 |
| • Fabric price group 4 | +\$ 134 |
| • Fabric price group 5 | +\$ 175 |
| • Fabric price group 6 | +\$ 214 |
| • Fabric price group 7 | +\$ 255 |
| • Fabric price group 8 | +\$ 321 |
| • Fabric price group 9 | +\$ 401 |
| • Fabric price group 10 | +\$ 456 |
| • Leather price group | +\$2775 |
| • Customer's Own Material (COM) | +\$ 32 |
| • Customer's Own Leather (COL) | +\$ 32 |
| • Fire Code Seating (FCS) | +\$ 416 |

- Specify fabric color number.
- Specify fabric color number.
- Specify fabric color number.
- Specify fabric color number.
- Specify fabric color number.
- Specify fabric color number.
- Specify fabric color number.
- Specify fabric color number.
- Specify fabric color number.
- Specify fabric color number.
- Specify fabric color number.
- Add suffix **L** to style number and specify leather color number.
- ▶ See *Understanding Customer's Own Material (COM)*, page 260.
- Add suffix **L** to style number and specify leather color number.
- Add suffix **F** to style number and specify fabric color number.

Multiple upholstery fabrics

- | | |
|---|--------|
| • Two or more fabrics on different chair components | +\$ 57 |
|---|--------|
- ▶ See below and at right.

Add suffix **M** to lounge chair style number and select fabric color number for:

- 1 Seat
- 2 Inner back
- 3 Outer back
- 4 Arms

Example: TS31407M with T015 on seat, T016 on inner back, T017 on outer back, and T018 on arms.

Add suffix **F** to style number and specify fabric color number.

- | | |
|---------------------------|---------|
| • Fire Code Seating (FCS) | +\$ 416 |
|---------------------------|---------|

1 Fabric on seat

- | | |
|-------------------------|---------|
| • Fabric price group 1 | No cost |
| • Fabric price group 2 | +\$ 11 |
| • Fabric price group 3 | +\$ 28 |
| • Fabric price group 4 | +\$ 38 |
| • Fabric price group 5 | +\$ 50 |
| • Fabric price group 6 | +\$ 62 |
| • Fabric price group 7 | +\$ 74 |
| • Fabric price group 8 | +\$ 94 |
| • Fabric price group 9 | +\$ 116 |
| • Fabric price group 10 | +\$ 132 |
| • Leather price group | +\$ 792 |

- Specify fabric color number.
- Specify fabric color number.
- Specify fabric color number.
- Specify fabric color number.
- Specify fabric color number.
- Specify fabric color number.
- Specify fabric color number.
- Specify fabric color number.
- Specify fabric color number.
- Specify fabric color number.
- Specify fabric color number.
- Specify fabric color number.
- Add suffix **L** to style number and specify leather color number.

- | | |
|---------------------------------|--------|
| • Customer's Own Material (COM) | +\$ 16 |
| • Customer's Own Leather (COL) | +\$ 16 |

▶ See *Understanding Customer's Own Material (COM)*, page 260.

Add suffix **L** to style number and specify leather color number.

▶ Options, continued on next page



For Canadian Pricing

Multiply U.S. Price by the Canadian price factor.

▶ See page 1 for details.

► Options, continued from previous page

Options	U.S. Price	Required to Specify
Surface Materials (continued)		
2 Fabric on inner back		
• Fabric price group 1	No cost	Specify fabric color number.
• Fabric price group 2	+\$ 8	Specify fabric color number.
• Fabric price group 3	+\$ 20	Specify fabric color number.
• Fabric price group 4	+\$ 27	Specify fabric color number.
• Fabric price group 5	+\$ 35	Specify fabric color number.
• Fabric price group 6	+\$ 43	Specify fabric color number.
• Fabric price group 7	+\$ 51	Specify fabric color number.
• Fabric price group 8	+\$ 64	Specify fabric color number.
• Fabric price group 9	+\$ 80	Specify fabric color number.
• Fabric price group 10	+\$ 92	Specify fabric color number.
• Leather price group	+\$ 401	Specify fabric color number. Add suffix L to style number and specify leather color number.
• Customer's Own Material (COM)	+\$ 16	► See <i>Understanding Customer's Own Material (COM)</i> , page 260.
• Customer's Own Leather (COL)	+\$ 16	Add suffix L to style number and specify leather color number.
3 Fabric on outer back		
• Fabric price group 1	No cost	Specify fabric color number.
• Fabric price group 2	+\$ 6	Specify fabric color number.
• Fabric price group 3	+\$ 14	Specify fabric color number.
• Fabric price group 4	+\$ 21	Specify fabric color number.
• Fabric price group 5	+\$ 26	Specify fabric color number.
• Fabric price group 6	+\$ 32	Specify fabric color number.
• Fabric price group 7	+\$ 38	Specify fabric color number.
• Fabric price group 8	+\$ 48	Specify fabric color number.
• Fabric price group 9	+\$ 60	Specify fabric color number.
• Fabric price group 10	+\$ 69	Specify fabric color number.
• Leather price group	+\$ 557	Specify fabric color number. Add suffix L to style number and specify leather color number.
• Customer's Own Material (COM)	+\$ 16	► See <i>Understanding Customer's Own Material (COM)</i> , page 260.
• Customer's Own Leather (COL)	+\$ 16	Add suffix L to style number and specify leather color number.
4 Fabric on arms		
• Fabric price group 1	No cost	Specify fabric color number.
• Fabric price group 2	+\$ 15	Specify fabric color number.
• Fabric price group 3	+\$ 34	Specify fabric color number.
• Fabric price group 4	+\$ 48	Specify fabric color number.
• Fabric price group 5	+\$ 63	Specify fabric color number.
• Fabric price group 6	+\$ 77	Specify fabric color number.
• Fabric price group 7	+\$ 93	Specify fabric color number.
• Fabric price group 8	+\$ 115	Specify fabric color number.
• Fabric price group 9	+\$ 145	Specify fabric color number.
• Fabric price group 10	+\$ 164	Specify fabric color number.
• Leather price group	+\$1061	Specify fabric color number. Add suffix L to style number and specify leather color number.
• Customer's Own Material (COM)	+\$ 16	► See <i>Understanding Customer's Own Material (COM)</i> , page 260.
• Customer's Own Leather (COL)	+\$ 16	Add suffix L to style number and specify leather color number.
Legs		
• Brushed Aluminum legs	+\$ 100	Specify with <i>Brushed Aluminum legs</i> .
• Solid maple wood legs	+\$ 133	Specify with <i>solid maple wood legs</i> and select 3412 Natural Cherry or 3762 Dark Walnut.

Jenny Lounge

Tip: Brushed Aluminum legs are adjustable and have 3/4" of height adjustment.

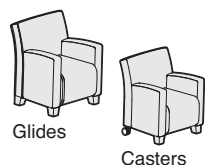

Specification Information

Style Number	U.S. Base Price	Style Number	U.S. Base Price
--------------	-----------------	--------------	-----------------

With Glides		With Two Casters and Two Glides	
TS31407	\$1144	TS31407C	\$1186

► Options, continued from previous page

Options	U.S. Price	Required to Specify
Surface Materials (continued)		
② Fabric on inner back		
• Fabric price group 1	No cost	Specify fabric color number.
• Fabric price group 2	+\$ 8	Specify fabric color number.
• Fabric price group 3	+\$ 20	Specify fabric color number.
• Fabric price group 4	+\$ 27	Specify fabric color number.
• Fabric price group 5	+\$ 35	Specify fabric color number.
• Fabric price group 6	+\$ 43	Specify fabric color number.
• Fabric price group 7	+\$ 51	Specify fabric color number.
• Fabric price group 8	+\$ 64	Specify fabric color number.
• Fabric price group 9	+\$ 80	Specify fabric color number.
• Fabric price group 10	+\$ 92	Specify fabric color number.
• Leather price group	+\$ 401	Specify fabric color number. Add suffix L to style number and specify leather color number.
• Customer's Own Material (COM)	+\$ 16	► See <i>Understanding Customer's Own Material (COM)</i> , page 260.
• Customer's Own Leather (COL)	+\$ 16	Add suffix L to style number and specify leather color number.
③ Fabric on outer back		
• Fabric price group 1	No cost	Specify fabric color number.
• Fabric price group 2	+\$ 6	Specify fabric color number.
• Fabric price group 3	+\$ 14	Specify fabric color number.
• Fabric price group 4	+\$ 21	Specify fabric color number.
• Fabric price group 5	+\$ 26	Specify fabric color number.
• Fabric price group 6	+\$ 32	Specify fabric color number.
• Fabric price group 7	+\$ 38	Specify fabric color number.
• Fabric price group 8	+\$ 48	Specify fabric color number.
• Fabric price group 9	+\$ 60	Specify fabric color number.
• Fabric price group 10	+\$ 69	Specify fabric color number.
• Leather price group	+\$ 557	Specify fabric color number. Add suffix L to style number and specify leather color number.
• Customer's Own Material (COM)	+\$ 16	► See <i>Understanding Customer's Own Material (COM)</i> , page 260.
• Customer's Own Leather (COL)	+\$ 16	Add suffix L to style number and specify leather color number.

Jenny Lounge

Specification Information

Style Number	U.S. Base Price

Round

TS31409	\$1333
---------	--------

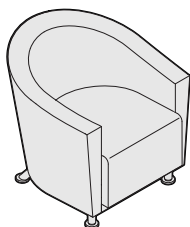

For Canadian Pricing

Multiply U.S. Price by the Canadian price factor.

► See page 1 for details.

Jenny Lounge, continued

With Wood Arms

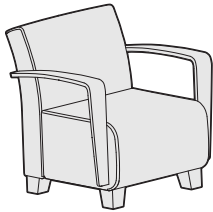

Tip: Tablet arm is only available on armless and one arm versions of Jenny.

Tip: Jenny lounge products have a relaxed appearance. They may show soft comfort wrinkles upon use.

Tip: Due to natural variations in wood, finished products may vary in color, texture, and grain.

Tip: Leather price group option ships at extended lead times.

Tip: Jenny lounge chairs are available with multiple fabrics.

▶ See at right to specify.

Tip: When specifying multiple fabrics and Fire Code Seating, specify suffix **F** at the end of the style number. Example: TS31401MF

Tip: When specifying multiple COM fabrics, indicate all surfaces where COM applies. Example: TS31408M with Designtex 1234 on seat, Designtex 5678 on inner back, and Designtex 9012 on outer back.

Tip: When specifying multiple fabrics and leather, specify suffix **M** before suffix **L**. Example: TS31408ML TS31408CML

Standard Includes	Required to Specify
<ul style="list-style-type: none"> Fully upholstered lounge chair: fabric price group 1 Plywood arm: maple veneer Deck stitch detail Legs with glides: black plastic Shipped fully assembled Meets Cal. 116 and 117 requirements 	<ul style="list-style-type: none"> 1 Style number 2 Fabric color number for upholstery 3 Wood color number for arms 4 Options, if selected (see below) ▶ See <i>Surface Materials</i>, page 196.

Options	U.S. Price	Required to Specify
Surface Materials		
Single upholstery fabric		
• Fabric price group 1	No cost	Specify fabric color number.
• Fabric price group 2	+\$ 26	Specify fabric color number.
• Fabric price group 3	+\$ 60	Specify fabric color number.
• Fabric price group 4	+\$ 85	Specify fabric color number.
• Fabric price group 5	+\$ 111	Specify fabric color number.
• Fabric price group 6	+\$ 137	Specify fabric color number.
• Fabric price group 7	+\$ 163	Specify fabric color number.
• Fabric price group 8	+\$ 206	Specify fabric color number.
• Fabric price group 9	+\$ 257	Specify fabric color number.
• Fabric price group 10	+\$ 291	Specify fabric color number.
• Leather price group	+\$1794	Specify fabric color number. Add suffix L to style number and specify leather color number.
• Customer's Own Material (COM)	+\$ 32	▶ See <i>Understanding Customer's Own Material (COM)</i> , page 260.
• Customer's Own Leather (COL)	+\$ 32	Add suffix L to style number and specify leather color number.
• Fire Code Seating (FCS)	+\$ 260	Add suffix F to style number and specify fabric color number.

Options	U.S. Price	Required to Specify
Multiple upholstery fabrics		
• Two or more fabrics on different chair components	+\$ 57	Add suffix M to lounge chair style number and select fabric color number for:
▶ See below and at right.		<ul style="list-style-type: none"> 1 Seat 2 Inner back 3 Outer back Example: TS31408M with T015 on seat, T016 on inner back, and T017 on outer back.
1 Fabric on seat		
• Fabric price group 1	No cost	Specify fabric color number.
• Fabric price group 2	+\$ 11	Specify fabric color number.
• Fabric price group 3	+\$ 28	Specify fabric color number.
• Fabric price group 4	+\$ 38	Specify fabric color number.
• Fabric price group 5	+\$ 50	Specify fabric color number.
• Fabric price group 6	+\$ 62	Specify fabric color number.
• Fabric price group 7	+\$ 74	Specify fabric color number.
• Fabric price group 8	+\$ 94	Specify fabric color number.
• Fabric price group 9	+\$ 116	Specify fabric color number.
• Fabric price group 10	+\$ 132	Specify fabric color number.
• Leather price group	+\$ 857	Specify fabric color number. Add suffix L to style number and specify leather color number.
• Customer's Own Material (COM)	+\$ 16	▶ See <i>Understanding Customer's Own Material (COM)</i> , page 260.
• Customer's Own Leather (COL)	+\$ 16	Add suffix L to style number and specify leather color number.

▶ Options, continued on next page



For Canadian Pricing

Multiply U.S. Price by the Canadian price factor.

▶ See page 1 for details.

Jenny Lounge, continued

Ottoman

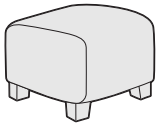

Tip: Jenny lounge products have a relaxed appearance. They may show soft comfort wrinkles upon use.

Tip: Hard dual-wheel casters are for use on carpet. Use on hard surfaces, including floor mats, will affect chair stability and may result in personal injury.

Tip: Leather price group option ships at extended lead times.

Tip: Jenny ottoman is available with multiple fabrics.
▶ See at right to specify.

Tip: When specifying multiple fabrics and Fire Code Seating, specify suffix **F** at the end of the style number.
Example: TS31401MF

Tip: When specifying multiple COM fabrics, indicate all surfaces where COM applies.
Example: TS31405M with Designtex 1234 on seat, front, and back and Designtex 9012 on sides.

Tip: When specifying multiple fabrics and leather, specify suffix **M** before suffix **L**.
Example: TS31401ML
TS31401CML

Standard Includes	Required to Specify
<ul style="list-style-type: none"> Fully upholstered ottoman: fabric price group 1 Hard dual-wheel casters or legs with glides: black plastic Meets Cal. 116 and 117 requirements 	<ul style="list-style-type: none"> 1 Style number 2 Fabric color number for upholstery 3 Options, if selected (see below) ▶ See <i>Surface Materials</i>, page 196.

Surface Materials	Options	U.S. Price	Required to Specify
	Single upholstery fabric		
	<ul style="list-style-type: none"> Fabric price group 1 Fabric price group 2 Fabric price group 3 Fabric price group 4 Fabric price group 5 Fabric price group 6 Fabric price group 7 Fabric price group 8 Fabric price group 9 Fabric price group 10 Leather price group 	<ul style="list-style-type: none"> No cost +\$ 16 +\$ 37 +\$ 54 +\$ 70 +\$ 85 +\$102 +\$129 +\$161 +\$182 +\$932 	<ul style="list-style-type: none"> Specify fabric color number. Specify fabric color number. Specify fabric color number. Specify fabric color number. Specify fabric color number. Specify fabric color number. Specify fabric color number. Specify fabric color number. Specify fabric color number. Specify fabric color number. Specify fabric color number. Add suffix L to style number and specify leather color number. ▶ See <i>Understanding Customer's Own Material (COM)</i>, page 260. Add suffix L to style number and specify leather color number. Add suffix F to style number and specify fabric color number.
	<ul style="list-style-type: none"> Customer's Own Material (COM) Customer's Own Leather (COL) Fire Code Seating (FCS) 	<ul style="list-style-type: none"> +\$ 32 +\$ 32 +\$200 	

Multiple upholstery fabrics

- Two or more fabrics on different components
- ▶ See below and at right.

1 Fabric on seat, front, and back

- Fabric price group 1
- Fabric price group 2
- Fabric price group 3
- Fabric price group 4
- Fabric price group 5
- Fabric price group 6
- Fabric price group 7
- Fabric price group 8
- Fabric price group 9
- Fabric price group 10
- Leather price group

- Customer's Own Material (COM)
- Customer's Own Leather (COL)

- Add suffix **M** to ottoman style number and select fabric color number for:
 - Seat, front, and back
 - Sides
 Example: TS31405M with T015 on seat, front, and back and T016 on sides.

- Specify fabric color number.
- Specify fabric color number.
- Specify fabric color number.
- Specify fabric color number.
- Specify fabric color number.
- Specify fabric color number.
- Specify fabric color number.
- Specify fabric color number.
- Specify fabric color number.
- Specify fabric color number.
- Specify fabric color number.
- Add suffix **L** to style number and specify leather color number.
- ▶ See *Understanding Customer's Own Material (COM)*, page 260.
- Add suffix **L** to style number and specify leather color number.

▶ Options, continued on next page



For Canadian Pricing

Multiply U.S. Price by the Canadian price factor.
▶ See page 1 for details.

► Options, continued from previous page

Options		U.S. Price	Required to Specify
Surface Materials (continued)	② Fabric on sides	No cost	Specify fabric color number.
	• Fabric price group 1		Specify fabric color number.
	• Fabric price group 2	+\$ 4	Specify fabric color number.
	• Fabric price group 3	+\$ 9	Specify fabric color number.
	• Fabric price group 4	+\$ 14	Specify fabric color number.
	• Fabric price group 5	+\$ 17	Specify fabric color number.
	• Fabric price group 6	+\$ 22	Specify fabric color number.
	• Fabric price group 7	+\$ 26	Specify fabric color number.
	• Fabric price group 8	+\$ 32	Specify fabric color number.
	• Fabric price group 9	+\$ 41	Specify fabric color number.
• Fabric price group 10	+\$ 46	Specify fabric color number.	
• Leather price group	+\$327	Add suffix L to style number and specify leather color number.	
	• Customer's Own Material (COM)	+\$ 16	► See <i>Understanding Customer's Own Material (COM)</i> , page 260.
	• Customer's Own Leather (COL)	+\$ 16	Add suffix L to style number and specify leather color number.
	Legs		
	• Brushed Aluminum legs	+\$100	Specify with <i>Brushed Aluminum legs</i> .
	• Solid maple wood legs	+\$133	Specify with <i>solid maple wood legs</i> and select 3412 Natural Cherry, 3522 Clear Maple, or 3762 Dark Walnut.

Tip: Brushed Aluminum legs are adjustable and have 3/4" of height adjustment.

Specification Information

• Style Number	• U.S. Base Price	• Style Number	• U.S. Base Price
With Glides		With Casters	
TS31405	\$492	TS31405C	\$576

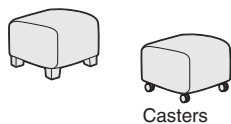

Ganging Kit

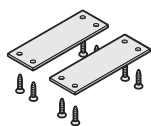

Standard Includes	Required to Specify
<ul style="list-style-type: none"> • Ganging kit • Two plates • Attachment hardware 	Style number

Specification Information

• Dimensions D W	• Style Number	• U.S. Price
2" 6"	TS31410	\$25



For Canadian Pricing
Multiply U.S. Price by the Canadian price factor.
► See page 1 for details.

Occasional Tables

Standard Includes	Required to Specify
<ul style="list-style-type: none"> • Table: Low-Pressure Laminate (LPL) or High-Pressure Laminate (HPL) • 3 mm edge band: plastic • Legs with glides: black plastic 	<ol style="list-style-type: none"> 1 Style number 2 Low-Pressure Laminate or High-Pressure Laminate color number for table, as appropriate 3 Plastic edge band color number for table 4 Options, if selected <p>▶ See <i>Surface Materials</i>, page 196.</p>

Options	U.S. Price	Required to Specify
Surface Materials • High-Pressure Laminate worksurfaces • Open Line laminate	+\$ 64 plus cost of laminate	▶ See <i>Surface Materials Reference Manual</i> .
Legs • Brushed aluminum legs • Solid maple wood legs	+\$100 +\$133	Specify with <i>brushed aluminum legs</i> . Specify with <i>solid maple wood legs</i> and select 3412 Natural Cherry, 3522 Clear Maple, or 3762 Dark Walnut.

Tip: Brushed aluminum legs are adjustable and have 3/4" of height adjustment.

Tip: There may be sheen or texture differences when using LPL and HPL in adjacent applications. Please use caution when mixing and matching different worksurface types.

Specification Information						
• Dimensions			• Style	• U.S.	• Style	• U.S.
D	W	H	Number	Base	Number	Base
			LPL	Price	HPL	Price

End Table

26½"	13½"	17"	TS31415L	\$296	TS31415H	\$327
:	:	:	:	:	:	:

Coffee Table

26½"	26½"	17"	TS31416L	\$404	TS31416H	\$435
:	:	:	:	:	:	:

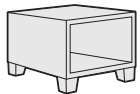
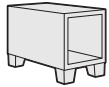

For Canadian Pricing
 Multiply U.S. Price by the Canadian price factor.
 ▶ See page 1 for details.

Understanding and Specifying Lincoln Lounge Lounge Seating



Product Details

Dimensions 186



Specifying

Lincoln Lounge 188

Dimensions

Lincoln Lounge

Features	Overall Depth	Width	Height	Functional Seat Depth	Seat Width	Seat Height from Floor	Back Width	Back Height from Seat	Width Between Arms
Lincoln Lounge									
Lounge Seating									
	32"	33"	34 ¹ / ₂ "	20 ⁵ / ₈ "	21 ¹ / ₂ "	16 ⁷ / ₈ "	21 ³ / ₈ "	20 ⁹ / ₁₆ "	23"

• Arm
Rest
Width

• Arm
Rest
Length

• Arm
Height
to Floor

5¹/₁₆"

7⁷/₈"

10³/₄"

Lincoln Lounge

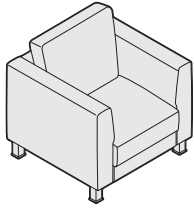

Tip: Legs need to be assembled onto the lounge seating.

Tip: The Jenny tablet arm cannot be installed on Lincoln chairs.

Standard Includes	Required to Specify
<ul style="list-style-type: none"> • Seat and back: Leather • Balance of the chair: simulated leather • Post legs: 8043 Clear Anodized Aluminum or 0835 Black • Shipped ready to assemble • Meets Cal. 116 and 117 requirements 	<ul style="list-style-type: none"> 1 Style number 2 Upholstery color number for seat and back: <ul style="list-style-type: none"> L304 Black Leather L305 Brown Leather

Specification Information

• Style Number	• U.S. Price

Lincoln Lounge with Post Legs

TS31601	\$964



For Canadian Pricing
 Multiply U.S. Price by the Canadian price factor.
 ▶ See page 1 for details.

Understanding and Specifying alight Lounge

Lounge Seating



Product Details

Dimensions **190**



Specifying

alight Lounge **191**

Dimensions

alight Lounge

Features **Overall**
: **Depth** **Width** **Height**
:
:
:

alight Lounge

Lounge Seating

Round	24"	24"	19"
Corner Ottoman	18"	31"	19"
Bench Ottoman	18"	36"	19"

Standard Includes	Required to Specify
<ul style="list-style-type: none"> Fully upholstered ottoman: fabric price group 1 Four adjustable-height legs: brushed aluminum Meets Cal. 116 and 117 requirements 	<ul style="list-style-type: none"> 1 Style number 2 Fabric color number for upholstery 3 Options, if selected (see below) ▶ See <i>Surface Materials</i>, page 196.

Surface Materials	Options	U.S. Price	Required to Specify
	Upholstery <ul style="list-style-type: none"> Fabric price group 1 Fabric price group 2 Fabric price group 3 Fabric price group 4 Fabric price group 5 Fabric price group 6 Fabric price group 7 Fabric price group 8 Fabric price group 9 Fabric price group 10 Customer's Own Material (COM) Fire Code Seating (FCS) 	<ul style="list-style-type: none"> No cost +\$ 16 +\$ 37 +\$ 54 +\$ 70 +\$ 85 +\$102 +\$129 +\$161 +\$182 +\$ 32 +\$ 80 	<ul style="list-style-type: none"> Specify fabric color number. Specify fabric color number. Specify fabric color number. Specify fabric color number. Specify fabric color number. Specify fabric color number. Specify fabric color number. Specify fabric color number. Specify fabric color number. Specify fabric color number. Add suffix F to the style number and specify fabric color number.
	Legs <ul style="list-style-type: none"> Solid maple wood legs 	<ul style="list-style-type: none"> +\$ 31 	<ul style="list-style-type: none"> Specify with <i>solid maple wood legs</i> and select 3412 Natural Cherry, 3522 Clear Maple, or 3762 Dark Walnut.
	Glides <ul style="list-style-type: none"> Low profile glide 	<ul style="list-style-type: none"> No cost 	<ul style="list-style-type: none"> Specify with <i>low profile glides</i>.

Tip: Due to natural variations in wood, finished products may vary in color, texture and grain.

Tip: Finish 3522 Clear Maple is a clear coat and therefore the natural variations in wood will be visible.

Tip: Adding low profile glide option reduces the overall height of the ottoman from 19" to 16".

*Tip: When specifying Fire Code Seating, specify suffix **F** at the end of the style number.
Example: TS34401F*

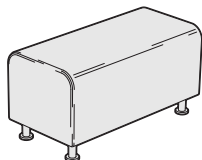
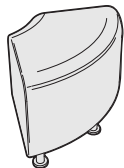
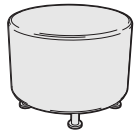

Specification Information	
<ul style="list-style-type: none"> Style Number U.S. Base Price 	<ul style="list-style-type: none"> Style Number U.S. Base Price

Round Ottoman	
TS34401	\$492

Corner Ottoman	
TS34402	\$546

Bench Ottoman	
TS34403	\$601

 **For Canadian Pricing**
Multiply U.S. Price by the Canadian price factor.
▶ See page 1 for details.

alight Lounge, continued

Ganging Kit

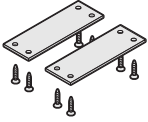

Standard Includes	Required to Specify
<ul style="list-style-type: none"> • Ganging kit • Two plates • Attachment hardware 	Style number

Specification Information

• Dimensions		• Style	• U.S.
D	W	Number	Price
2"	6"	TS31410	\$25

Occasional Tables

Tip: Due to natural variations in wood, finished products may vary in color, texture and grain.

Tip: Finish 3522 Clear Maple is a clear coat and therefore the natural variations in wood will be visible.

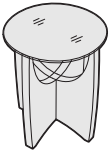

Tip: End table base is reversible, creating two unique looks.



Standard Includes	Required to Specify
<ul style="list-style-type: none"> • Table: maple veneer base • Veneer edge band to match base • 3/8" clear glass top • Glides 	1 Style number 2 Wood color number for base ▶ See <i>Surface Materials</i> , page 196.

Specification Information

• Dimensions			• Style	• U.S.
D	W	H	Number	Price

End Table

18"	18"	23"	TS34410T	\$536
-----	-----	-----	-----------------	-------

Coffee Table

30"	30"	17"	TS34411T	\$692
-----	-----	-----	-----------------	-------



For Canadian Pricing
 Multiply U.S. Price by the Canadian price factor.
 ▶ See page 1 for details.

Understanding and Specifying Crushed Can Lounge Seating



Product Details

Dimensions **194**



Specifying

Crushed Can **195**

Dimensions

Crushed Can

Features	Overall		
	Depth	Width	Height
.	.	.	.
.	.	.	.
.	.	.	.
.	.	.	.

Crushed Can

Lounge Seating

Small Can	13 ¹ / ₂ "	17 ¹ / ₂ "	20"
Medium Can	13 ¹ / ₂ "	17 ¹ / ₂ "	24"
Large Can	13 ¹ / ₂ "	17 ¹ / ₂ "	28"

Crushed Can Stools

Tip: Fabrics, COMs and COLs are available on upholstered body only.

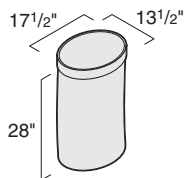
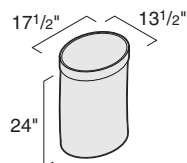
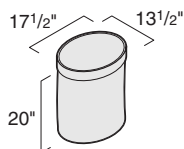
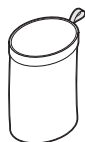

Standard Includes	Required to Specify
<ul style="list-style-type: none"> • Top and bottom: 5783 Black vinyl only • Upholstered body: fabric price group 1 • Shipped fully assembled • Meets Cal. 116 and 117 requirements 	<ul style="list-style-type: none"> 1 Style number 2 Fabric color number for upholstered body 3 Options, if selected (see below) ▶ See <i>Surface Materials</i>, page 196.

Surface Materials	Options	U.S. Price	Required to Specify
	Upholstery <ul style="list-style-type: none"> • Fabric price group 1 • Fabric price group 2 • Fabric price group 3 • Fabric price group 4 • Fabric price group 5 • Fabric price group 6 • Fabric price group 7 • Fabric price group 8 • Fabric price group 9 • Fabric price group 10 • Customer's Own Material (COM) 	<ul style="list-style-type: none"> No cost +\$ 22 +\$ 43 +\$ 59 +\$ 75 +\$ 92 +\$107 +\$134 +\$166 +\$187 +\$ 32 	<ul style="list-style-type: none"> Specify fabric color number. Specify fabric color number. Specify fabric color number. Specify fabric color number. Specify fabric color number. Specify fabric color number. Specify fabric color number. Specify fabric color number. Specify fabric color number. Specify fabric color number. ▶ See <i>Understanding Customer's Own Material (COM)</i>, page 260.
	Handle <ul style="list-style-type: none"> • Looped vinyl handle 	<ul style="list-style-type: none"> +\$ 24 	<ul style="list-style-type: none"> Specify <i>with handle</i>.

Specification Information

Style Number	U.S. Base Price

Small Can

TS33666	\$174

Medium Can

TS33667	\$187

Large Can

TS33668	\$200

Crushed Can

For Canadian Pricing
 Multiply U.S. Price by the Canadian price factor.
 ▶ See page 1 for details.

Surface Materials

► For Surface Materials matrices for all product lines, see page 241.

Paint

Steelcase Surfaces

Applies to:

- Scoop
- 4799 Platinum Metallic
- 7207 Black

Applies to:

- Jenny tablet arm
- 7207 Black

Applies to:

- Lincoln Lounge legs
- 8043 Clear Anodized Aluminum
- 0835 Black **E**

Plastic

Steelcase Surfaces

Applies to:

- Jenny tablet arm
- Jenny end table
- Jenny coffee table
- 6000 Black
- 6009 Arctic White
- 6034 Natural Cherry
- 6037 Winter On Maple
- 6053 Seagull
- 6234 Clear Cherry
- 6242 Virginia Walnut
- 6243 Blackwood
- 6245 Clear Walnut
- 6246 Warm Oak
- 6636 Mist
- 6654 Sand
- 6655 Warm White
- 6676 Marbled Maple
- 6677 Chocolate Walnut
- 6678 Marbled Cherry
- 6689 Brushed Silver

Applies to:

- Scoop
- 6618 White
- 6682 Cobblestone

Tip: Established finishes are available for delivery in 15 business days.

E = Established

Laminate

Steelcase Surfaces

Low-Pressure Laminate

Applies to:

- Jenny tablet arm
- Jenny end table
- Jenny coffee table
- 247L Black Version 2 LPL
- 25L1 Winter on Maple LPL
- 25L5 Virginia Walnut LPL
- 25L6 Blackwood LPL
- 25L8 Clear Walnut LPL
- 25L9 Warm Oak LPL
- 262L Marbled Maple LPL
- 264L Chocolate Walnut LPL
- 267L Marbled Cherry Version 2 LPL
- 26L1 Natural Cherry (Version 2) LPL
- 2L03 Brushed Silver LPL
- 2L30 Arctic White LPL
- 2L50 Vanadium Fiber LPL
- 2L52 Tungsten Fiber LPL
- 2L83 Seagull LPL
- 2L85 Dune LPL

High-Pressure Laminate

Applies to:

- Jenny tablet arm
- Jenny end table
- Jenny coffee table
- 2406 Clear Cherry
- 2412 Natural Cherry
- 2503 Brushed Silver HPL
- 2511 Winter on Maple
- 2535 Virginia Walnut HPL
- 2536 Blackwood HPL
- 2538 Clear Walnut HPL
- 2539 Warm Oak HPL
- 2612 Marbled Maple
- 2614 Chocolate Walnut
- 2615 Marbled Cherry Version 2
- 2730 Arctic White
- 2746 Black
- 2850 Vanadium Fiber
- 2852 Tungsten Fiber
- 2883 Seagull
- 2885 Dune

Note: Some wood veneer finishes and woodgrain laminates share the same name. Because of the difference in materials, veneers and laminates of the same name are not an exact match but do coordinate with each other.

Custom Surfaces

Open Line Laminate (OLL)

This service allows you to order non-standard laminate at an additional processing fee of \$64 U.S. per work surface or top, plus the cost of the laminate.

When processing orders for Open Line laminate on Turnstone products, specify 2900 in the laminate finish field and enter the OLL manufacturer information. Enter the required edge finish as you would a standard laminate.

Edge color for the Open Line laminate on Turnstone products must be determined by the dealer and customer before orders can be entered. Specify appropriate 2K finish number.

Tip: Standard laminates being used in the Open Line Laminate program to obtain a different edge detail will be charged the Open Line laminate upcharge; however, no additional charges for the laminate will be applied.

Laminate Approval and Material Requirements

To confirm whether a particular laminate has already been tested for use on a specific Steelcase product or to determine material square foot requirements:

- Visit www.steelcase.com

For additional information, refer to the *Steelcase Surface Materials Reference Manual*.

Wood

Steelcase Surfaces

Applies to:

- Jenny wood legs
- Jenny wood arm
- aLight wood legs
- aLight end table
- aLight coffee table
- 3412 Natural Cherry **E**
- 3522 Clear Maple
- 3762 Dark Walnut

Tip: Due to natural variations in wood, finished products may vary in color, texture and grain.

Upholstery

Steelcase Surfaces

Not every upholstery is available on every chair. Please refer to the upholstery matrix on page 256 before specifying.

Price Group 1

- Buzz2
- Jacks
- Link
- Playground
- Seating Vinyl

Price Group 2

- Cogent: Connect
- Cogent: Geode Seating
- Cogent: Geode Vertical
- Cogent: Trails
- Cricket
- Crosswalk
- Nitelights
- Regis2
- Spyder **E**
- Stand In
- Zoe2

Price Group 3

- Cogent: Tides
- Hampstead

Price Group 5

- Bo Peep

Price Group 6

- Brisa

Turnstone Leather

Steelcase Surfaces

Applies to:

- Lincoln Lounge
- L304 Black
- L305 Brown

Turnstone Collection by DesignTex

DesignTex and Turnstone partnered to create an exclusive collection of affordable seating textiles that offer fresh and exciting designs.

This collection of textiles is stocked and available in standard lead-time. Fabrics are supported just like standard fabrics, which makes ordering easy. This program is supported by a swatch card that presents the entire offering. The swatch card is available to order through ad-stock # 08-0000726.

Price Group 2

- Ludington - 3285

Price Group 3

- Boyne - 3280
- Great Lakes - 3282

Price Group 4

- Glen Arbor - 3283
- Leland - 3281
- Saugatuck - 3284

Reply Select

Reply seat color number defaults based on the mesh back selection.

Mesh back:	Default seat:
AR01 Air Grey	5G64 Alpine
AR02 Air Black	5F17 Black
AR06 Air Apple Green	5G59 Meadow
AR09 Air Sable	5G51 Sable

cobi Select

cobi seat color number defaults based on the mesh back selection.

Back:	Default seat:
5018 Scarlet	5S18 Scarlet
5019 Concord	5S19 Concord
5020 Maya Blue	5S20 Maya Blue
5021 Blue Jay	5S21 Blue Jay
5023 Wasabi	5S23 Wasabi
5025 Graphite	5S25 Graphite
5026 Licorice	5S26 Licorice
5028 Root Beer	5S28 Root Beer

Uno Select

Uno seat color number defaults based on the mesh back selection.

5S15 Coconut
5S16 Turmeric
5S17 Tangerine
5S18 Scarlet
5S19 Concord
5S20 Maya Blue
5S21 Blue Jay
5S23 Wasabi
5S24 Nickel
5S25 Graphite
5S26 Licorice
5S28 Root Beer

Select Surfaces

For information on products within Select Surfaces, including accent paints and fabrics from Designtex, Maharam, and Pollack, please refer to the *Surface Materials Reference Manual* or visit [Steelcase.com/selectsurfaces](http://steelcase.com/selectsurfaces).

Custom Surfaces

Price Group COM (Customer's Own Material)

Fabric Approval and Yardage

To confirm whether a particular COM material has already been tested for use on a specific Steelcase product or to determine actual yardage requirements:

- Visit www.steelcase.com

For additional information regarding Customer's Own Material, call 1.888.STEELCASE.

Custom Surfaces

Customer's Own Material (COM) Program

The Customer's Own Material (COM) program offers the opportunity for customers to select fabrics that are not offered through the standard Steelcase surface materials program for use on Steelcase products. Once approved, you can place your order. Steelcase will facilitate the entire ordering process and give you a production schedule. Steelcase will order the COM fabric directly from the textile manufacturer. For up-to-date information regarding fabric test results for all COM fabrics and details regarding yardage requirements for most seating lines, visit the COM website on www.steelcase.com. COMs are not covered under the Steelcase warranty.

Soil Retardants

Soil retardants are treatments that provide long-term soil and stain resistance to a fabric without affecting the shade or the integrity of the fabric. The following Steelcase Textiles and Turnstone Collection by Designtex fabrics are available pre-treated with soil retardant:

- Boyne
- Glen Arbor
- Jacks
- Link
- Saugatuck
- Spyder



Tables



Statement of Line

Table Components	200
Sweeper Martini	200
Jenny	200
alight	200



Product Details

Table Component Facts	201
------------------------------	------------



Specifying

Table Components	202
Power Access and Cable Management	204
Sweeper	
Martini Table	205
Jenny	
Occasional Tables	206
alight Lounge	
Occasional Tables	207



Surface Materials	208
--------------------------	------------

Statement of Line

Table Components

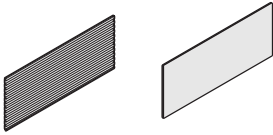

Desk-Mounted Screens
▶ Page 202

Sweeper Martini

Table:



Martini
▶ Page 205

Jenny

Tables:

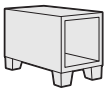

End Table
▶ Page 206

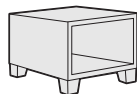

Coffee Table
▶ Page 206

alight

Tables:

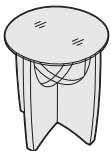

End Table
▶ Page 207



Coffee Table
▶ Page 207

Table Component Facts

► Specifying, page 202

Screens can be attached above the worksurface to the left, right, and rear sides of table desks.

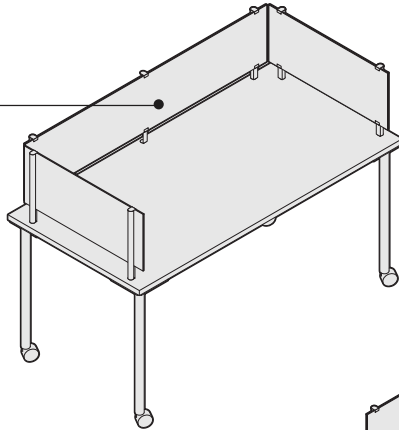

Screen attaches to the rear of rectangular table desk top.

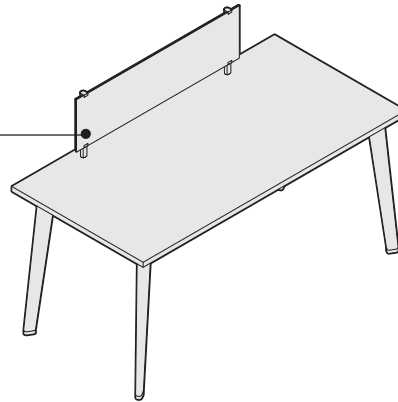

Product Details

Screens, 6" smaller than table desks, do not extend full width or full depth of worksurface.

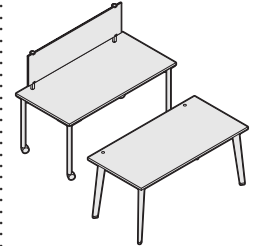
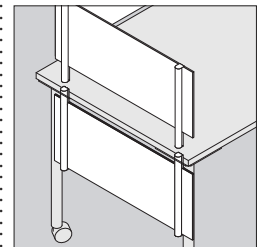

Table desk tops are shipped without screen holes. To attach screens, holes must be drilled on site using the supplied template. Plugs are available through Service Parts (TS5YGMTSR) when screens are not in use and have been removed from the top.



Screen attaches above the worksurface for use as a privacy panel or below the worksurface for use as a modesty panel. Mounting brackets, ordered separately, must be used when attaching screens above and below a worksurface.
► Page 203

Table Components

Desk-Mounted Screens

For Use Above or Below the Worksurface

Standard Includes	Required to Specify
<ul style="list-style-type: none"> ▶ Need help? Product details, page 201 • Translucent screen, if selected: plastic • Slatwall screen, if selected: paint price group 1 	<ul style="list-style-type: none"> 1 Style number 2 Color number for translucent screen, if selected 3 Paint color number for slatwall screen, if selected 4 Options, if selected (see below) ▶ See <i>Surface Materials</i>, page 208.

Options	U.S. Price	Required to Specify
Surface Materials <ul style="list-style-type: none"> • Slatwall screen • Paint price group 1 • Paint price group 2 	No cost +\$16	Specify paint color number. Specify paint color number.
Related Products <ul style="list-style-type: none"> • Mounting brackets • Privacy-modesty adapters 		▶ Page 203 ▶ Page 203

Tip: Mounting brackets must be ordered with screens.

Specification Information				
Dimensions	Style			U.S. Base Price
	D	W	H	

Translucent Screens

1/4"	18"	12"	TS5YTS1218	\$131
1/4"	27"	12"	TS5YTS1227	\$142
1/4"	30"	12"	TS5YTS1230	\$154
1/4"	36"	12"	TS5YTS1236	\$180
1/4"	44"	12"	TS5YTS1244	\$220
1/4"	60"	12"	TS5YTS1260	\$230
1/4"	18"	18"	TS5YTS1818	\$142
1/4"	27"	18"	TS5YTS1827	\$181
1/4"	30"	18"	TS5YTS1830	\$232
1/4"	36"	18"	TS5YTS1836	\$258
1/4"	44"	18"	TS5YTS1844	\$270
1/4"	60"	18"	TS5YTS1860	\$298

Slatwall Screens

1/4"	18"	12"	TS5YSL1218	\$164
1/4"	26 3/4"	12"	TS5YSL1226	\$204
1/4"	30"	12"	TS5YSL1230	\$218
1/4"	36"	12"	TS5YSL1236	\$241
1/4"	43 1/2"	12"	TS5YSL1244	\$269
1/4"	60"	12"	TS5YSL1260	\$315

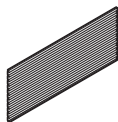
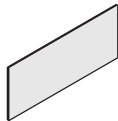

For Canadian Pricing
Multiply U.S. Price by the Canadian price factor.
▶ See page 1 for details.

Screen Mounting Brackets and Adapters

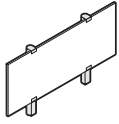

Tip: Package of three mounting brackets is to be used with 60"W screens only. Package of two mounting brackets is for use with all other applications.

Standard Includes		Required to Specify
<ul style="list-style-type: none"> ▶ Need help? Product details, page 201 	<ul style="list-style-type: none"> • Mounting brackets and hardware: paint price group 1 	<ul style="list-style-type: none"> 1 Style number 2 Paint color number for mounting brackets and hardware 3 Options, if selected (see below) ▶ See <i>Surface Materials</i>, page 208.

Options	U.S. Price	Required to Specify
Surface Materials <ul style="list-style-type: none"> • Paint price group 1 • Paint price group 2 	No cost +\$10	Specify paint color number. Specify paint color number.

Specification Information

Dimensions			Style Number	U.S. Base Price
D	W	H		
:	:	:	:	:

Package of Two Mounting Brackets

1½"	2"	15"	TS5YMB212	\$134
1½"	3"	21"	TS5YMB218	\$149

Package of Three Mounting Brackets

1½"	2"	15"	TS5YMB312	\$179
1½"	3"	21"	TS5YMB318	\$185

Standard Includes		Required to Specify
<ul style="list-style-type: none"> • Package of two privacy-modesty adapters 		Style number

Specification Information

Height	Style Number	U.S. Price
:	:	:

Package of Two Privacy-Modesty Adapters

4"	TS5YMBADP	\$19
----	------------------	------

Tip: Order privacy-modesty adapter when attaching one screen directly above or below another.

 **For Canadian Pricing**
Multiply U.S. Price by the Canadian price factor.
▶ See page 1 for details.

Power Access and Cable Management

Skeleton Bone Wire Manager

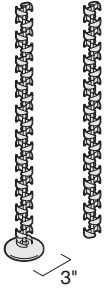

Standard Includes				Required to Specify	
<ul style="list-style-type: none"> • Wire manager: black plastic • Attachment hardware 				Style number	
Specification Information					
Dimensions			Style	U.S.	
D	W	H	Number	Price	
Skeleton Bone Wire Manager					
1½"	1¾"	38"	TS5SKLBNE	\$157	
Skeleton Bone Wire Manager Extension					
1½"	1¾"	36"	TS5SKEXT	\$133	

Wire Manager



Tip: Attaches under work-surfaces with screws or around leg.

Standard Includes				Required to Specify	
<ul style="list-style-type: none"> • Package of four wire managers • Attachment package 				Style number	
Specification Information					
Dimensions			Style	U.S.	
D	W	H	Number	Price	
1½"	8"	1½"	TS5LEGCLP	\$45	



For Canadian Pricing
 Multiply U.S. Price by the Canadian price factor.
 ▶ See page 1 for details.

Sweeper Martini Table

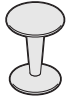

Standard Includes	Required to Specify
-------------------	---------------------

- Durable body: plastic
- Shipped fully assembled

- 1 Style number
- 2 Plastic color number for table
- ▶ See *Surface Materials*, page 208.

Specification Information				
• Dimensions			• Style	• U.S.
D	W	H	Number	Price

18"	18"	23 ¹ / ₂ "	TS39150	\$134
-----	-----	----------------------------------	----------------	-------



For Canadian Pricing
 Multiply U.S. Price by the
 Canadian price factor.
 ▶ See page 1 for details.

Jenny Occasional Tables

Standard Includes	Required to Specify
<ul style="list-style-type: none"> Table: Low-Pressure Laminate (LPL) or High-Pressure Laminate (HPL) 3 mm edge band: plastic Legs with glides: black plastic 	<ol style="list-style-type: none"> Style number Low-Pressure Laminate or High-Pressure Laminate color number for table, as appropriate Plastic edge band color number for table Options, if selected (see below) <p>▶ See <i>Surface Materials</i>, page 208.</p>

Tip: Brushed Aluminum legs are adjustable and have 3/4" of height adjustment.

Tip: There may be sheen or texture differences when using LPL and HPL in adjacent applications. Please use caution when mixing and matching different worksurface types.

Options	U.S. Price	Required to Specify
Surface Materials ▶ Page 208	High-Pressure Laminate worksurfaces <ul style="list-style-type: none"> Open Line laminate +\$ 64 plus cost of laminate 	▶ See <i>Surface Materials Reference Manual</i> .
	Legs <ul style="list-style-type: none"> Brushed Aluminum legs +\$100 Solid maple wood legs +\$133 	Specify with <i>Brushed Aluminum legs</i> . Specify with <i>solid maple wood legs</i> and select 3412 Natural Cherry, 3522 Clear Maple, or 3762 Dark Walnut.

Specification Information

• Dimensions			• Style	• U.S.	• Style	• U.S.
D	W	H	Number	Price	Number	Base Price
			LPL		HPL	

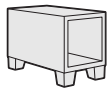

End Table

26 1/2"	13 1/2"	17"	TS31415L	\$296	TS31415H	\$327

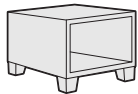

Coffee Table

26 1/2"	26 1/2"	17"	TS31416L	\$404	TS31416H	\$435



For Canadian Pricing
 Multiply U.S. Price by the Canadian price factor.
 ▶ See page 1 for details.

alight Lounge

Occasional Tables

Tip: Due to natural variations in wood, finished products may vary in color, texture and grain.

Tip: Finish 3522 Clear Maple is a clear coat and therefore the natural variations in wood will be visible.

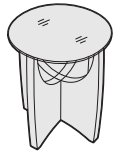

Standard Includes	Required to Specify
-------------------	---------------------

- Table: maple veneer base
- 3 mm edge band to match table
- Clear glass top
- Glides

- 1 Style number
- 2 Wood color number for base
- ▶ See *Surface Materials*, page 208.

Specification Information				
Dimensions			Style	U.S.
D	W	H	Number	Price

End Table

18"	18"	23"	TS34410T	\$536
-----	-----	-----	-----------------	-------

Coffee Table

30"	30"	17"	TS34411T	\$692
-----	-----	-----	-----------------	-------



For Canadian Pricing
 Multiply U.S. Price by the Canadian price factor.
 ▶ See page 1 for details.

Surface Materials

► For Surface Materials matrices for all product lines, see page 241.

Laminate

Steelcase Surfaces

Low-Pressure Laminate

Applies to:

- Jenny end table
- Jenny coffee table
- 25L1 Winter on Maple LPL
- 25L5 Virginia Walnut LPL
- 25L6 Blackwood LPL
- 25L8 Clear Walnut LPL
- 25L9 Warm Oak LPL
- 26L1 Natural Cherry Version 2 LPL
- 2L30 Arctic White LPL

High-Pressure Laminate

Applies to:

- Jenny end table
- Jenny coffee table
- 2412 Natural Cherry Version 2 HPL
- 2511 Winter on Maple HPL
- 2535 Virginia Walnut HPL
- 2536 Blackwood HPL
- 2538 Clear Walnut HPL
- 2539 Warm Oak HPL
- 2730 Arctic White HPL

Note: Some wood veneer finishes and woodgrain laminates share the same name. Because of the difference in materials, veneers and laminates of the same name are not an exact match but do coordinate with each other.

Custom Surfaces

Open Line Laminate (OLL)

This service allows you to order non-standard laminate at an additional processing fee of \$64 U.S. per worksurface or top, plus the cost of the laminate.

When processing orders for Open Line laminate on Turnstone products, specify 2900 in the laminate finish field and enter the OLL manufacturer information. Enter the required edge finish as you would a standard laminate.

Edge color for the Open Line laminate on Turnstone products must be determined by the dealer and customer before orders can be entered. Specify appropriate 2K finish number. *Tip: Standard laminates being used in the Open Line Laminate program to obtain a different edge detail will be charged the Open Line laminate upcharge; however, no additional charges for the laminate will be applied.*

Laminate Approval and Material Requirements

To confirm whether a particular laminate has already been tested for use on a specific Steelcase product or to determine material square foot requirements:

- Visit www.steelcase.com

For additional information, refer to the *Steelcase Surface Materials Reference Manual*.

Plastic

Steelcase Surfaces

Applies to:

- Jenny end table edge band
 - Jenny coffee table edge band
 - 6000 Black*
 - 6009 Arctic White*
 - 6034 Natural Cherry
 - 6037 Winter On Maple
 - 6053 Seagull*
 - 6234 Clear Cherry*
 - 6242 Virginia Walnut*
 - 6243 Blackwood*
 - 6245 Clear Walnut*
 - 6246 Warm Oak*
 - 6636 Mist*
 - 6654 Sand*
 - 6655 Warm White*
 - 6676 Marbled Maple
 - 6677 Chocolate Walnut
 - 6678 Marbled Cherry
 - 6689 Brushed Silver*
- *These solid color and wood grain edge colors are a polyolefin blend, PVC-free material for 3 mm and 1 mm edge bandings.

Applies to:

- Translucent screens
- 6505 Frosted White
- 6506 Frosted Blue
- 6507 Frosted Green

Applies to:

- Sweeper Martini table
- 627T Black
- 628T Natural
- 631T Dark Grey

Wood

Steelcase Surfaces

Applies to:

- Jenny wood legs
- aight tables
- 3412 Natural Cherry **E**
- 3522 Clear Maple
- 3762 Dark Walnut

Tip: Due to natural variations in wood, finished products may vary in color, texture, and grain.

Paint

Steelcase Surfaces

Applies to:

- Screen mounting brackets
- Slatwall screens

Price Group 1

- 7207 Black
- 7225 Sand
- 7241 Arctic White
- 7243 Seagull

Price Group 2

- 4750 Champagne Metallic
- 4798 Sterling Metallic
- 4799 Platinum Metallic
- 7246 Midnight Metallic

E = Established

Details

Ergonomic Worktools

			
Statement of Line	210	Organizational Tools, continued	
		SOTO	
Computer Support		Rails	226
Keyboard Supports		Cableways	227
19" Keyboard Platforms with Lift-and-Lock Mechanism	212	Shelves	228
Lift and Lock with Enviro Platform and Green-Gel Palm Rest	213	Display Shelves	228
Slider Keyboard Platforms and Stella Mechanism	214	LED Task Lights	229
Jules Keyboard Platforms and Stella Mechanism	215	Tool Box	230
Flat Panel Monitor Arms		Pile Box	230
FYI Flat Panel Monitor Arm	216	Diagonal File Box	230
Flat Panel Monitor Arm	216	Personal Box	231
Flat Panel Monitor Pole Mounts	217	Landscape Letter Box	231
Flat Panel Monitor Brackets	218	Utility Box	231
Monitor and Processing Tools		Storage Box, Set of Three	232
Adjustable Foot Rest	219	Worktools	
Vertical Non-Locking CPU Cradle	219	Binder Holder	233
Vertical Processor Sling	219	Hanging Brackets	233
Freestanding In-Line Document Support	220	Letter Tray	234
I/Q CPU Trolley	220	Media Holder	234
Organizational Tools		Telephone Caddy	235
SlatRail		Personal Shelf	235
SlatRail	221	Pen/Pencil Cup	236
SlatRail Panel-Mount Brackets	221	Double Square Dish	236
SlatRail Wall-Mount Brackets	222	Utility Hook	237
Freestanding SlatRail Stanchions	222	Simple Trolley	237
Slatwall		Project Container	238
Slatwall Tiles	223	File Container	238
Slatwall Brackets	224	Details Lighting	
Freestanding Slatwall Stanchions	225	Personal Underline Task Light	239
		Details Tables	
		AdjusTables Series 5	240

Statement of Line

Details Ergonomic Worktools

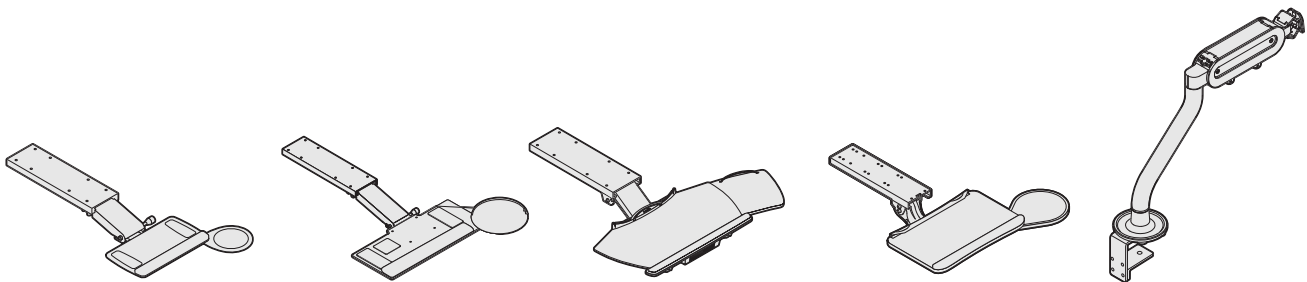

19" Keyboard Platforms with Lift-and-Lock Mechanism and Green-Gel Palm Rest
▶ Page 212

Lift and Lock with Enviro Platform and Green-Gel Palm Rest
▶ Page 213

Slider Keyboard Platforms and Stella Mechanism
▶ Page 214

Jules Keyboard Platforms and Stella Mechanism
▶ Page 215

FYI Flat Panel Monitor Arm
▶ Page 216

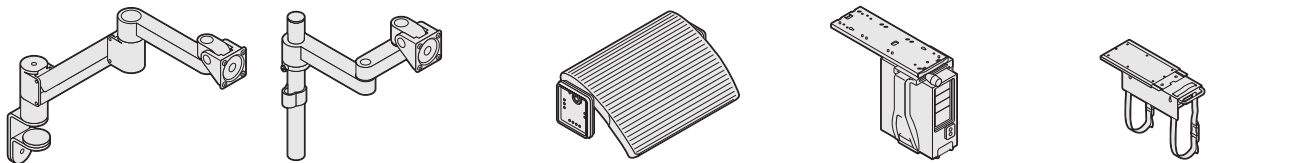

Flat Panel Monitor Arm
▶ Page 216

Flat Panel Monitor Pole Mounts
▶ Page 217

Adjustable Foot Rest
▶ Page 219

Vertical Non-Locking CPU Cradle
▶ Page 219

Vertical Processor Sling
▶ Page 219

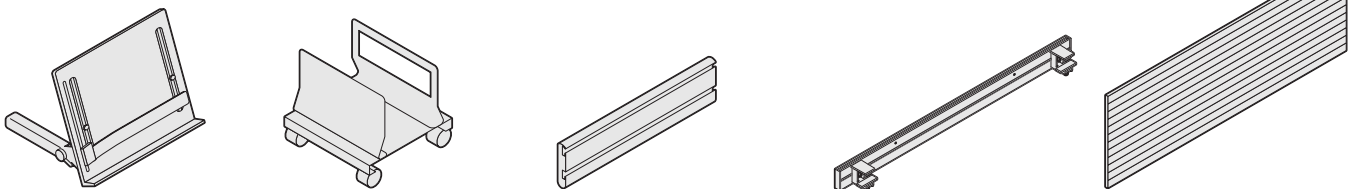

Freestanding In-Line Document Support
▶ Page 220

I/Q CPU Trolley
▶ Page 220

SlatRail
▶ Page 221

SOTO Rail
▶ Page 226

Slatwall Tiles
▶ Page 223

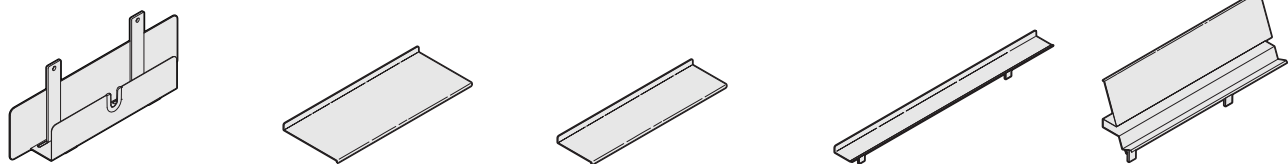

SOTO Cableway
▶ Page 227

10" Shelf
▶ Page 228

6" Shelf
▶ Page 228

3" Shelf
▶ Page 228

Display Shelf
▶ Page 228

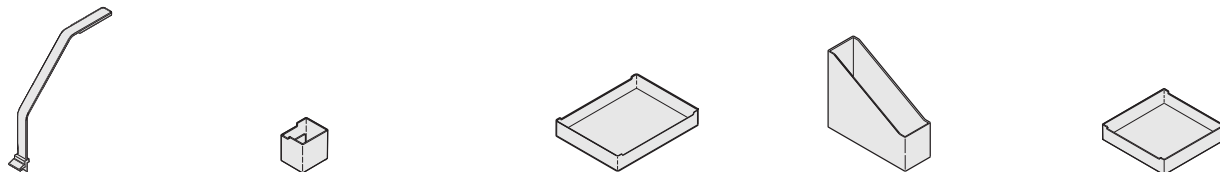

SOTO LED Task Lights
▶ Page 229

Tool Box
▶ Page 230

Pile Box
▶ Page 230

Diagonal File Box
▶ Page 230

Personal Box
▶ Page 231

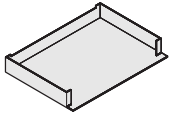

Landscape Letter Box
▶ Page 231

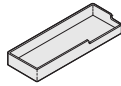

Utility Box
▶ Page 231

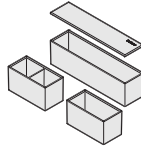

Storage Box, Set of 3
▶ Page 232

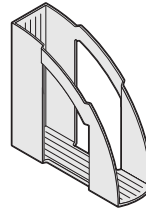

Binder Holder
▶ Page 233

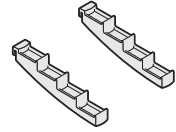

Hanging Brackets
▶ Page 233

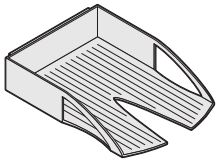

Letter Tray
▶ Page 234



Media Holder
▶ Page 234

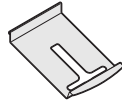

Telephone Caddy
▶ Page 235

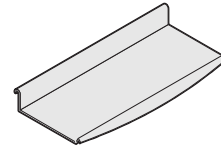

Personal Shelf
▶ Page 235

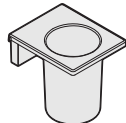

Pen/Pencil Cup
▶ Page 236

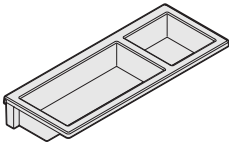

Double Square Dish
▶ Page 236



Utility Hook
▶ Page 237



Simple Trolley
▶ Page 237



Project Container
▶ Page 238

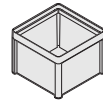

File Container
▶ Page 238

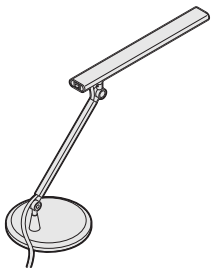

Personal Underline Task Light
▶ Page 239

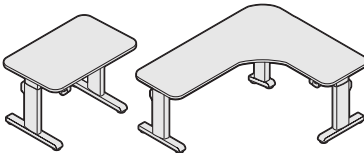

Adjustable Series 5
▶ Page 240

Keyboard Supports

19" Keyboard Platforms with Lift-and-Lock Mechanism

Tip: 19" platform can be used in 12" radius corners using 23" track.

Tip: Be sure to consider the mechanism track length in relationship to the work surface depth.

Tip: Requires 20"W knee-space clearance.

Tip: Remove the palm rest if using a Microsoft natural keyboard.

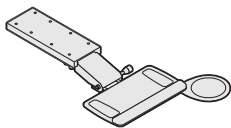
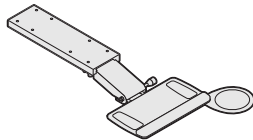

Standard Includes	Required to Specify
-------------------	---------------------

- Keyboard platform: 7027 Charcoal
- Tilt mechanism
- 7" arm, if selected, adjusts from 7³/₄" below the worksurface to 3" above the track
- 5" arm, if selected, adjusts from 5³/₄" below the worksurface to 2¹/₂" above the track
- Mouse surface, attached on right
- Tilt range +/- 15°

Style number

Specification Information				
• Dimensions			• Style	• U.S.
D	W	H	Number	Price

9 ³ / ₄ "	19"*	1/4"	L72619MRGG	\$286
:	:	:	:	:

7" Arm with 26" Track

9 ³ / ₄ "	19"*	1/4"	L72619MRGG	\$286
:	:	:	:	:

5" Arm with 23¹/₄" Track

9 ³ / ₄ "	19"*	1/4"	L52319MRGG	\$286
:	:	:	:	:

*8" round mouse surface attached.

Products on this page are Details, not Turnstone. They are included here to simplify your planning. Remember that Details has different pricing terms than Turnstone products.



For Canadian Pricing
 Multiply U.S. Price by the Canadian price factor.
 ▶ See page 1 for details.

Lift and Lock with Enviro Platform and Green-Gel Palm Rest

Tip: Be sure to consider the mechanism track length in relationship to the work surface depth.

Tip: Remove the palm rest if using a Microsoft natural keyboard.

Standard Includes	Required to Specify
<ul style="list-style-type: none"> • Keyboard platform: 7027 Charcoal • Tilt mechanism • 7" arm, if selected, adjusts from 7¾" below the work surface to 3" above the track • 5" arm, if selected, adjusts from 5¾" below the work surface to 2½" above the track • Integral mouse surface • Foam palm rest 	Style number

Specification Information

• Dimensions			• Style	• U.S.
D	W	H	Number	Price

7" Arm with 23" Track

11"	26"	¼"	L726EN10GG	\$286

5" Arm with 18" Track

11"	26"	¼"	L523EN10GG	\$286

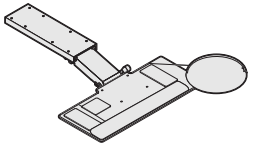
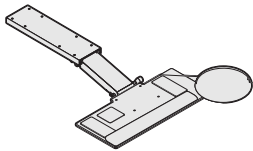

Products on this page are Details, not Turnstone. They are included here to simplify your planning. Remember that Details has different pricing terms than Turnstone products.



For Canadian Pricing
 Multiply U.S. Price by the Canadian price factor.
 ▶ See page 1 for details.

Keyboard Supports, continued

Slider Keyboard Platforms and Stella Mechanism

Tip: Slider platform can be used in 12" radius corners when used with an extended mechanism.

Tip: Be sure to consider the mechanism track length in relationship to the work surface depth.

Tip: Requires 20"W knee-space clearance.

Standard Includes	Required to Specify
<ul style="list-style-type: none"> • Keyboard platform: metal • Tilt mechanism that adjusts from 5" below to 2" above the worksurface • Standard Stella mechanism, if selected, requires 20"D worksurface clearance • Extended Stella mechanism, if selected, requires 25"D worksurface clearance • Ambidextrous, integrated mouse surface • Foam palm rest 	<ul style="list-style-type: none"> 1 Style number 2 Paint color number for keyboard platform: <ul style="list-style-type: none"> 7018 Pewter 7027 Charcoal

Specification Information

• Dimensions	• Style	• U.S.
D W H	Number	Price

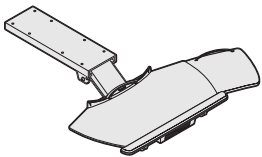

Slider Platform with Standard Stella Mechanism

9 ¹ / ₂ "	20"	3"	SS20SL10SA	\$490
---------------------------------	-----	----	-------------------	-------

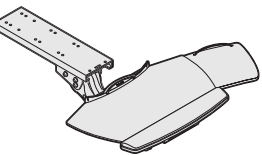

Slider Platform with Extended Stella Mechanism

9 ¹ / ₂ "	20"	3"	SE23SL10SA	\$505
---------------------------------	-----	----	-------------------	-------

Products on this page are Details, not Turnstone. They are included here to simplify your planning. Remember that Details has different pricing terms than Turnstone products.

For Canadian Pricing
 Multiply U.S. Price by the Canadian price factor.
 ▶ See page 1 for details.

Jules Keyboard Platforms and Stella Mechanism

Tip: Jules platform can be used in 12" radius corners when used with an extended mechanism.

Tip: Be sure to consider the mechanism track length in relationship to the worksurface depth.

Tip: Requires 20"W knee-space clearance.

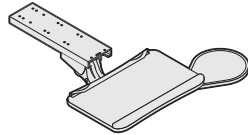
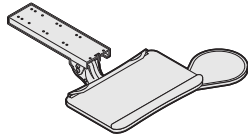

Tip: 8½" round mouse surface attached.

Standard Includes	Required to Specify
<ul style="list-style-type: none"> • Keyboard platform: plastic • Tilt mechanism that adjusts from 5" below to 2" above the worksurface • Standard Stella mechanism, if selected, requires 20"D worksurface clearance • Extended Stella mechanism, if selected, requires 25"D worksurface clearance • Ambidextrous, integrated mouse surface • Foam palm rest 	<ul style="list-style-type: none"> 1 Style number 2 Plastic color number for keyboard platform: <ul style="list-style-type: none"> 7018 Pewter 7027 Charcoal

Specification Information

• Dimensions			• Style	• U.S.
D	W	H	Number	Price

Platform with Standard Stella Mechanism

12"	18¾"	5⅝"	SS20JP10SF	\$391

Platform with Extended Stella Mechanism

12"	18¾"	5⅝"	SE23JP10SF	\$407

Products on this page are Details, not Turnstone. They are included here to simplify your planning. Remember that Details has different pricing terms than Turnstone products.



For Canadian Pricing
 Multiply U.S. Price by the Canadian price factor.
 ▶ See page 1 for details.

Flat Panel Monitor Arms

FYI Flat Panel Monitor Arm

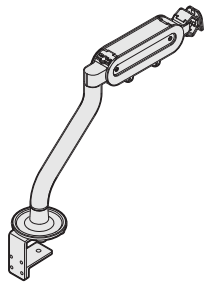

Tip: Flat panel monitor arm must be used with C-clamp mounting bracket, which is included.

Standard Includes	Required to Specify
-------------------	---------------------

- Flat panel monitor arm that supports monitors 5 to 20 lbs: paint
- 24" range of motion from the axis
- 11¹/₂" of height adjustment (based on application)
- 75 mm and 100 mm monitor mounting plates
- C-clamp mounting bracket

- 1 Style number
- 2 Paint color number for flat panel monitor arm:
 - 4231 Arctic White
 - 7018 Pewter
 - 7027 Charcoal

Specification Information		
Height	Style Number	U.S. Price

15"	FPASINGLECC	\$371
-----	--------------------	-------

Flat Panel Monitor Arm

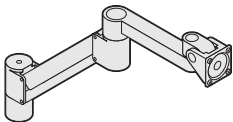

Tip: Flat panel monitor arm must be used with flat panel monitor brackets, ordered separately.

Standard Includes	Required to Specify
-------------------	---------------------

- Flat panel monitor arm that supports monitors 10 to 22 lb: paint
- 24" range of motion from the axis
- 16" of height adjustment (based on application)
- 75 mm and 100 mm monitor mounting plates

- 1 Style number
- 2 Paint color number for flat panel monitor arm:
 - 7018 Pewter
 - 7027 Charcoal

Related Products

- Flat panel monitor brackets ▶ Page 218

Specification Information		
Height	Style Number	U.S. Price

16"	CF800	\$404
-----	--------------	-------

Products on this page are Details, not Turnstone. They are included here to simplify your planning. Remember that Details has different pricing terms than Turnstone products.



For Canadian Pricing
 Multiply U.S. Price by the Canadian price factor.
 ▶ See page 1 for details.

Flat Panel Monitor Pole Mounts

Standard Includes	Required to Specify
<ul style="list-style-type: none"> Flat panel monitor pole mount: paint Horizontal arm(s) that supports monitors 5 to 35 lbs and adjusts vertically along the pole 14" extension from the pole 12" pole 	<ul style="list-style-type: none"> 1 Style number 2 Paint color number for pole mount: <ul style="list-style-type: none"> 7018 Pewter 7027 Charcoal

Related Products
<ul style="list-style-type: none"> Flat panel monitor brackets ▶ Page 218

Tip: Flat panel monitor arm must be used with flat panel monitor brackets, ordered separately.

Specification Information

Height	Style Number	U.S. Price
--------	--------------	------------

Single Arm Pole Mount

12"	CFSHA	\$305

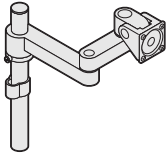

Double Arm Pole Mount

12"	CFDHA	\$520

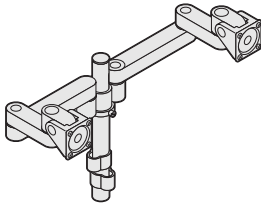

Products on this page are Details, not Turnstone. They are included here to simplify your planning. Remember that Details has different pricing terms than Turnstone products.



For Canadian Pricing
 Multiply U.S. Price by the Canadian price factor.
 ▶ See page 1 for details.

Flat Panel Monitor Brackets

Standard Includes	Required to Specify
<ul style="list-style-type: none"> • Desk-clamp or through-mount bracket: paint 	1 Style number 2 Paint color number for bracket: 7018 Pewter 7027 Charcoal

Related Products	
<ul style="list-style-type: none"> • Flat panel monitor arm • Flat panel monitor pole mounts 	<ul style="list-style-type: none"> ▶ Page 216 ▶ Page 217

Specification Information

• Style Number	• U.S. Price

Desk-Clamp/Grommet Bracket

CFSPC	\$47

Through-Mount Bracket

CFPTM	\$47

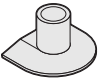
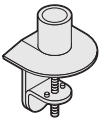

Products on this page are Details, not Turnstone. They are included here to simplify your planning. Remember that Details has different pricing terms than Turnstone products.



For Canadian Pricing
 Multiply U.S. Price by the Canadian price factor.
 ▶ See page 1 for details.

Monitor and Processing Tools

Adjustable Foot Rest

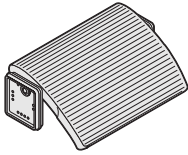

Standard Includes	Required to Specify
<ul style="list-style-type: none"> Adjustable foot rest: charcoal 	Style number

Specification Information

Dimensions			Style Number	U.S. Price
D	W	H		
12"	18"	2"-6"	CFTR	\$120

Vertical Non-Locking CPU Cradle

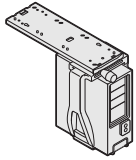

Tip: Will accept CPUs from 3 1/2"W to 9"W.

Standard Includes	Required to Specify
<ul style="list-style-type: none"> CPU cradle that supports CPU vertically: black Soft touch knob for side clamp adjustment Supports processors with weights up to 85 lbs 	Style number

Specification Information

Dimensions			Style Number	U.S. Price
D	W	H		
17"	9"	12 1/2"-22 1/2"	CPRCCN	\$166

Vertical Processor Sling

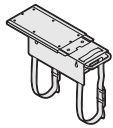

Standard Includes	Required to Specify
<ul style="list-style-type: none"> Worksurface-mounted vertical processor sling that requires 18"D worksurface clearance: black Adjustable straps that support computers with a 53"-maximum perimeter 10 1/2"D, up to 75 lbs 	Style number

Specification Information

Dimensions			Style Number	U.S. Price
D	W	H		
18"	5 1/2"	2 1/2"	CPRSL	\$135

Products on this page are Details, not Turnstone. They are included here to simplify your planning. Remember that Details has different pricing terms than Turnstone products.

 **For Canadian Pricing**
 Multiply U.S. Price by the Canadian price factor.
 ▶ See page 1 for details.

Monitor and Processing Tools, continued

Freestanding In-Line Document Support

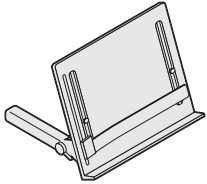

Standard Includes	Required to Specify
<ul style="list-style-type: none"> Freestanding in-line document support: black 	Style number

Specification Information

• Dimensions			• Style	• U.S.
D	W	H	Number	Price
18"	14"	12"	CDFIS14	\$109
·	·	·	·	·

I/Q CPU Trolley

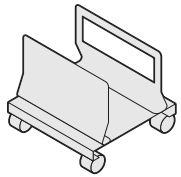

Tip: Will accept CPUs from 5¼"W to 8½"W.

Standard Includes	Required to Specify
<ul style="list-style-type: none"> I/Q CPU trolley that supports CPU vertically: chalk Two locking and two non-locking casters 	Style number

Specification Information

• Dimensions			• Style	• U.S.
D	W	H	Number	Price
10½"	5¼"–8½"	10"	QACPUT	\$101
·	·	·	·	·

Products on this page are Details, not Turnstone. They are included here to simplify your planning. Remember that Details has different pricing terms than Turnstone products.



For Canadian Pricing
 Multiply U.S. Price by the Canadian price factor.
 ▶ See page 1 for details.

SlatRail

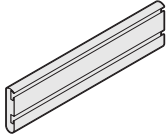

Tip: SlatRail is not dedicated to the exact panel width; a 12" overhang is acceptable.

Tip: Total dimensions of Worktools specified should not exceed SlatRail dimensions.

Tip: Two SlatRails cannot be used in a corner application.

Standard Includes	Required to Specify
<ul style="list-style-type: none"> SlatRail that supports up to 100 lb: paint 	<ul style="list-style-type: none"> 1 Style number 2 Paint color number for SlatRail: <ul style="list-style-type: none"> 0835 Black 4750 Champagne 4799 Platinum

Related Products	
<ul style="list-style-type: none"> SlatRail panel mount brackets SlatRail wall-mount brackets Freestanding SlatRail stanchions Worktools 	<ul style="list-style-type: none"> ▶ See below. ▶ Page 222 ▶ Page 222 ▶ Page 233

Specification Information				
Dimensions			Style	U.S.
D	W	H	Number	Price
3/4"	24"	4"	WSR24	\$ 62
3/4"	30"	4"	WSR30	\$ 74
3/4"	36"	4"	WSR36	\$ 85
3/4"	42"	4"	WSR42	\$ 97
3/4"	48"	4"	WSR48	\$109
3/4"	60"	4"	WSR60	\$132

SlatRail Panel-Mount Brackets



Standard Includes	Required to Specify
<ul style="list-style-type: none"> Pair of SlatRail panel brackets: 4799 Platinum 	<ul style="list-style-type: none"> Style number

Related Products	
<ul style="list-style-type: none"> SlatRail 	<ul style="list-style-type: none"> ▶ See above.

Specification Information			
Dimensions		Style	U.S.
W	H	Number	Price
2 1/2"	4 1/2"	WSRU1	\$35

Products on this page are Details, not Turnstone. They are included here to simplify your planning. Remember that Details has different pricing terms than Turnstone products.

 **For Canadian Pricing**
 Multiply U.S. Price by the Canadian price factor.
 ▶ See page 1 for details.

SlatRail, continued

SlatRail Wall-Mount Brackets

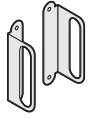

Standard Includes **Required to Specify**

- Pair of SlatRail wall-mount brackets: 4799 Platinum
- Style number

Related Products

- SlatRail
- ▶ Page 221

Specification Information

• Dimensions			• Style	• U.S.
D	W	H	Number	Price
2¾"	¾"	4¾"	WSRW	\$35

Freestanding SlatRail Stanchions

For Use on Worksurfaces and Materials ½" to 1¾" thick

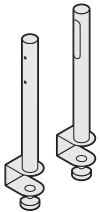

Tip: Positions top of SlatRail a fixed height of 12¾" above mounting surface.

Tip: Worksurface/table must be able to support 100 lbs.

Tip: Stanchion cannot be used in a corner application or on a glass surface.

Standard Includes **Required to Specify**

- Pair of SlatRail stanchions that requires 18"D worksurface and uses 2½" surface footprint: paint
- 1 Style number
2 Paint color number for SlatRail Stanchions:
0835 Black
4750 Champagne
4799 Platinum

Related Products

- SlatRail
- ▶ Page 221

Specification Information

• Dimensions			• Style	• U.S.
D	W	H	Number	Price
1½"	1½"	13½"	WSRFS	\$116

Products on this page are Details, not Turnstone. They are included here to simplify your planning. Remember that Details has different pricing terms than Turnstone products.



For Canadian Pricing
Multiply U.S. Price by the Canadian price factor.
▶ See page 1 for details.

Slatwall Tiles

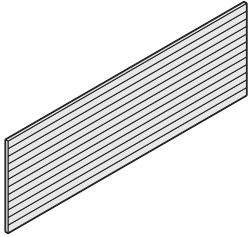

Tip: Total dimensions of Worktools specified should not exceed Slatwall dimensions.

Tip: Slatwall is not dedicated to the exact panel width; a 12" overhang is acceptable.

Tip: Two Slatwall tiles cannot be used in a corner application.

Standard Includes	Required to Specify
-------------------	---------------------

- | | |
|--|---|
| <ul style="list-style-type: none"> Slatwall tile that supports up to 60 lb: paint | <ul style="list-style-type: none"> 1 Style number 2 Paint color number for slatwall: <ul style="list-style-type: none"> 0835 Black 4799 Platinum 4750 Champagne |
|--|---|

Related Products

- | | |
|--|--|
| <ul style="list-style-type: none"> Slatwall brackets Freestanding Slatwall stanchions Worktools | <ul style="list-style-type: none"> ▶ Page 224 ▶ Page 225 ▶ Page 233 |
|--|--|

Specification Information				
Dimensions			Style	U.S.
D	W	H	Number	Price

1 1/8"	24"	12"	WS24	\$107
1 1/8"	30"	12"	WS30	\$120
1 1/8"	36"	12"	WS36	\$133
1 1/8"	42"	12"	WS42	\$155
1 1/8"	45"	12"	WS45	\$166
1 1/8"	48"	12"	WS48	\$177
1 1/8"	60"	12"	WS60	\$222

Products on this page are Details, not Turnstone. They are included here to simplify your planning. Remember that Details has different pricing terms than Turnstone products.



For Canadian Pricing
 Multiply U.S. Price by the Canadian price factor.
 ▶ See page 1 for details.

Slatwall Brackets

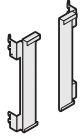

Standard Includes	Required to Specify
<ul style="list-style-type: none"> • Pair of slatwall brackets: paint 	<ul style="list-style-type: none"> 1 Style number 2 Paint color number for slatwall brackets: <ul style="list-style-type: none"> 0835 Black 4750 Champagne 4799 Platinum

Related Products
<ul style="list-style-type: none"> • Slatwall tiles

▶ Page 223

Specification Information

• Dimensions			• Style	• U.S.
D	W	H	Number	Price

Wall-Mount Brackets

1"	2"	12 ¹ / ₃ "	WSWM	\$33
----	----	----------------------------------	-------------	------

Kick Panel-Mount Brackets

1"	2"	12 ¹ / ₃ "	WSWANS	\$33
----	----	----------------------------------	---------------	------

Kick Panel-Mount Brackets for 42"H Panel

1"	2"	12 ¹ / ₃ "	WSW42AN	\$66
----	----	----------------------------------	----------------	------

Series 9000 and Avenir Panel-Mount Brackets

1"	2"	12 ¹ / ₃ "	WSWUSA	\$33
----	----	----------------------------------	---------------	------

Products on this page are Details, not Turnstone. They are included here to simplify your planning. Remember that Details has different pricing terms than Turnstone products.



For Canadian Pricing
 Multiply U.S. Price by the Canadian price factor.
 ▶ See page 1 for details.

Freestanding Slatwall Stanchions

For Use on Worksurfaces 1/2" to 3" thick

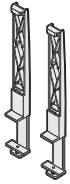

Tip: Positions top of Slatwall a fixed height of 15 1/2" above mounting surface.

Tip: Slatwall can overhang Stanchions up to 12".

Tip: Worksurface/table must be able to support 60 lbs.

Tip: Stanchion cannot be used in a corner application or on a glass surface.

Standard Includes	Required to Specify
<ul style="list-style-type: none"> • Pair of Slatwall stanchions that requires 18"D worksurface and uses 2" surface footprint: paint • Non-marring rubber feet 	<ul style="list-style-type: none"> 1 Style number 2 Paint color number for slatwall brackets: <ul style="list-style-type: none"> 0835 Black 4750 Champagne 4799 Platinum

Related Products
<ul style="list-style-type: none"> • Slatwall tiles ▶ Page 223

Specification Information				
• Dimensions			• Style	• U.S.
D	W	H	Number	Price
3"	3 1/2"	16"	WFCS	\$131

Products on this page are Details, not Turnstone. They are included here to simplify your planning. Remember that Details has different pricing terms than Turnstone products.



For Canadian Pricing
 Multiply U.S. Price by the Canadian price factor.
 ▶ See page 1 for details.

SOTO

Rails

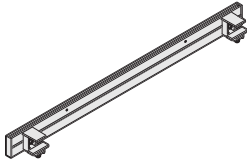

Tip: Rails clamp to free-standing worksurfaces or material up to 2" thick. Rails are not applicable for glass surfaces.

Standard Includes	Required to Specify
<ul style="list-style-type: none"> • Rail: 4799 Platinum 	Style number

Related Products	
<ul style="list-style-type: none"> • SOTO shelves • SOTO Worktools 	<ul style="list-style-type: none"> ▶ Page 228 ▶ Page 233

Specification Information				
• Dimensions			• Style	• U.S.
D	W	H	Number	Price
1"	28"	3¼"	DSR28	\$175
1"	34"	3¼"	DSR34	\$186
1"	40"	3¼"	DSR40	\$197
1"	46"	3¼"	DSR46	\$208
1"	52"	3¼"	DSR52	\$218
1"	58"	3¼"	DSR58	\$230
1"	64"	3¼"	DSR64	\$240

Tour Rails

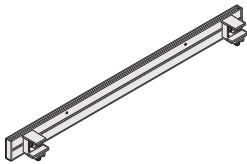

Tip: Allow 1" clearance between worksurface and rail for cable management. Allow 2" for rail mount installed behind a worksurface, and 3¾" overall to install the rail.

Tip: Maximum weight load for rails is 2 lbs per lineal inch.

Tip: Each clamp requires a 2" footprint above the work-surface, and a 3¼" clearance below the work-surface.

Tip: Tour rails clamp to Tour bench troughs. Rails are not applicable for glass surfaces.

Standard Includes	Required to Specify
<ul style="list-style-type: none"> • Rail: 4799 Platinum 	Style number

Related Products	
<ul style="list-style-type: none"> • SOTO shelves • SOTO Worktools 	<ul style="list-style-type: none"> ▶ Page 228 ▶ Page 233

Specification Information					
• Corresponding Table Top Width	• Dimensions			• Style	• U.S.
	D	W	H	Number	Price
60"	1"	52"	3¼"	DSRT52	\$218
66"	1"	58"	3¼"	DSRT58	\$230
72"	1"	64"	3¼"	DSRT64	\$240

Cableways

Tip: Cableway hangs fixed at 8" below the worksurface.

Standard Includes	Required to Specify
-------------------	---------------------

- Rail: 4799 Platinum

Style number

Related Products

- SOTO rails
- SOTO Worktools

- ▶ Page 228
- ▶ Page 233

Specification Information				
Dimensions			Style	U.S.
D	W	H	Number	Price

2½"	20"	18"	DSCW20	\$129
-----	-----	-----	---------------	-------

2½"	30"	18"	DSCW30	\$145
-----	-----	-----	---------------	-------

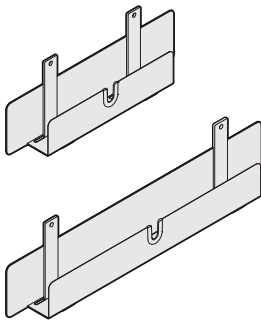

Products on this page are Details, not Turnstone. They are included here to simplify your planning. Remember that Details has different pricing terms than Turnstone products.



For Canadian Pricing
 Multiply U.S. Price by the Canadian price factor.
 ▶ See page 1 for details.

SOTO, continued

Shelves

Standard Includes	Required to Specify
<ul style="list-style-type: none"> ▶ Need help? See <i>Details SpecGuide</i> for product details. • Shelf: paint • Stanchions: 4799 Platinum 	<ul style="list-style-type: none"> 1 Style number 2 Paint color number for shelf: 4231 Arctic White 4799 Platinum

Specification Information

• Dimensions		• Style Number	• U.S. Price
D	W		
10 1/4"	24 1/2"	DSS2410	\$131
6 3/4"	24 1/2"	DSS246	\$109
3 1/2"	36"	DSS363	\$ 87

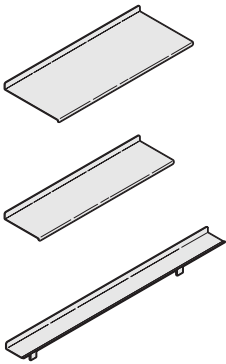

Display Shelves

Standard Includes	Required to Specify
<ul style="list-style-type: none"> ▶ Need help? See <i>Details SpecGuide</i> for product details. • Display shelf: paint • Stanchions: 4799 Platinum 	<ul style="list-style-type: none"> 1 Style number 2 Paint color number for shelf: 4231 Arctic White 4799 Platinum

Specification Information

• Dimensions			• Style Number	• U.S. Price
W	H	Overall/ Height		
5" High Stanchion				
24 1/2"	11 1/2"	14 3/4"	DDS245	\$158
8" High Stanchion				
24 1/2"	11 1/2"	17 1/4"	DDS248	\$170

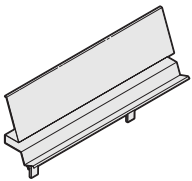

Tip: The 8" stanchions on DDS248 allow for other shelves to mount underneath.

Tip: Utility box can fit inside channel of the display shelf.



For Canadian Pricing
 Multiply U.S. Price by the Canadian price factor.
 ▶ See page 1 for details.

LED Task Lights

Standard Includes	Required to Specify
<ul style="list-style-type: none"> ▶ Need help? See <i>Details SpecGuide</i> for product details. • Light: paint • Power cord 	<ul style="list-style-type: none"> 1 Style number 2 Paint color number for light: <ul style="list-style-type: none"> 4231 Arctic White 4710 Low Gloss Black 4799 Platinum

Specification Information

• Dimensions			• Style Number	• U.S. Price
D	W	H		

Rail-Mounted

13 ¹ / ₈ "	1 ¹ / ₂ "	13 ¹ / ₈ "	DSLEDR	\$286

Freestanding

13 ¹ / ₈ "	4 ¹ / ₄ "	15 ³ / ₈ "	DSLEDF	\$312

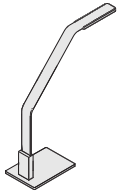
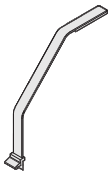

Mini LED Task Light

Standard Includes	Required to Specify
<ul style="list-style-type: none"> ▶ Need help? See <i>Details SpecGuide</i> for product details. • Light: 4799 Platinum • 9' power cord • Attachment hardware 	<ul style="list-style-type: none"> Style number

Specification Information

• Dimensions			• Style Number	• U.S. Price
D	W	H		

1 ¹ / ₂ "	7"	3 ⁵ / ₈ "	LMINILED	\$229

Products on this page are Details, not Turnstone. They are included here to simplify your planning. Remember that Details has different pricing terms than Turnstone products.



For Canadian Pricing
 Multiply U.S. Price by the Canadian price factor.
 ▶ See page 1 for details.

SOTO, continued

Tool Box



Tip: Tool box contains removable semi-opaque insert to separate pens from sticky notes.

Standard Includes		Required to Specify	
<ul style="list-style-type: none"> Need help? See <i>Details SpecGuide</i> for product details. 	<ul style="list-style-type: none"> Tool box: plastic 	<ul style="list-style-type: none"> 1 Style number 2 Plastic color number for box: 6000 Black, 6009 Arctic White 	

Specification Information				
Dimensions			Style Number	U.S. Price
D	W	H		
3 1/2"	3 1/4"	3 1/2"	DSTB	\$29

Pile Box

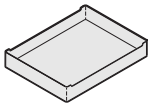

Standard Includes		Required to Specify	
<ul style="list-style-type: none"> Need help? See <i>Details SpecGuide</i> for product details. 	<ul style="list-style-type: none"> Pile box: plastic 	<ul style="list-style-type: none"> 1 Style number 2 Plastic color number for box: 6000 Black, 6009 Arctic White 	

Specification Information				
Dimensions			Style Number	U.S. Price
D	W	H		
9 7/8"	12 1/4"	2"	DSSPB	\$34

Diagonal File Box

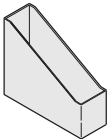

Products on this page are Details, not Turnstone. They are included here to simplify your planning. Remember that Details has different pricing terms than Turnstone products.

Standard Includes		Required to Specify	
<ul style="list-style-type: none"> Need help? See <i>Details SpecGuide</i> for product details. 	<ul style="list-style-type: none"> Diagonal file box: plastic 	<ul style="list-style-type: none"> 1 Style number 2 Plastic color number for box: 6000 Black, 6009 Arctic White 	

Specification Information				
Dimensions			Style Number	U.S. Price
D	W	H		
12 1/4"	4"	9 7/8"	DSDFB	\$34



For Canadian Pricing
 Multiply U.S. Price by the Canadian price factor.
 See page 1 for details.

Personal Box

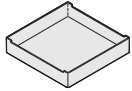

Standard Includes		Required to Specify
<ul style="list-style-type: none"> ▶ Need help? See <i>Details SpecGuide</i> for product details. 	<ul style="list-style-type: none"> • Personal box: plastic 	<ul style="list-style-type: none"> 1 Style number 2 Plastic color number for box: <ul style="list-style-type: none"> 6000 Black 6009 Arctic White

Specification Information				
• Dimensions			• Style	• U.S.
D	W	H	Number	Price
9"	9"	2"	DSPB	\$29
:	:	:	:	:

Landscape Letter Box

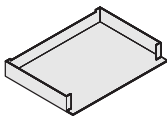

Standard Includes		Required to Specify
<ul style="list-style-type: none"> ▶ Need help? See <i>Details SpecGuide</i> for product details. 	<ul style="list-style-type: none"> • Landscape letter box: plastic 	<ul style="list-style-type: none"> 1 Style number 2 Plastic color number for box: <ul style="list-style-type: none"> 6000 Black 6009 Arctic White

Specification Information				
• Dimensions			• Style	• U.S.
D	W	H	Number	Price
97/8"	133/4"	2"	DSLLB	\$34
:	:	:	:	:

Utility Box

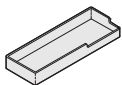

Standard Includes		Required to Specify
<ul style="list-style-type: none"> ▶ Need help? See <i>Details SpecGuide</i> for product details. 	<ul style="list-style-type: none"> • Utility box: plastic 	<ul style="list-style-type: none"> 1 Style number 2 Plastic color number for box: <ul style="list-style-type: none"> 6000 Black 6009 Arctic White

Specification Information				
• Dimensions			• Style	• U.S.
D	W	H	Number	Price
31/8"	9"	11/4"	DSUB	\$29
:	:	:	:	:

Products on this page are Details, not Turnstone. They are included here to simplify your planning. Remember that Details has different pricing terms than Turnstone products.



For Canadian Pricing
 Multiply U.S. Price by the Canadian price factor.
 ▶ See page 1 for details.

SOTO, continued

Storage Box, Set of Three

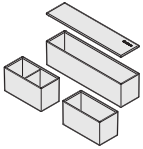

Tip: The storage box set fits inside the personal box.

Tip: The box dimensions are:
 • Large: 2 1/8" x 8 9/8" x 2 3/8"
 • Small with divider: 2 1/8" x 4 1/4" x 2 3/8"
 • Small without divider: 2 1/8" x 4 1/4" x 2 3/8"

Standard Includes	Required to Specify
<ul style="list-style-type: none"> ▶ Need help? See <i>Details SpecGuide</i> for product details. • Set of three storage boxes: semi-opaque boxes with white cover 	<ul style="list-style-type: none"> Style number

Specification Information	
• Style Number	• U.S. Price
DSSB	\$34
:	:
:	:

Products on this page are Details, not Turnstone. They are included here to simplify your planning. Remember that Details has different pricing terms than Turnstone products.

 **For Canadian Pricing**
 Multiply U.S. Price by the Canadian price factor.
 ▶ See page 1 for details.

Worktools

Binder Holder

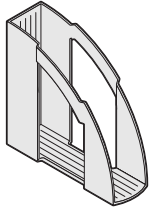

Standard Includes	Required to Specify
-------------------	---------------------

- Binder holder that supports binders and other reference materials: plastic

- 1 Style number
- 2 Plastic color number for binder holder:
 - 6000 Black
 - 6009 Arctic White
 - 6544 Frost
 - 6545 Amber
 - 6546 Rain

Related Products

- SlatRail
- Slatwall tiles

- ▶ Page 221
- ▶ Page 223

Specification Information				
---------------------------	--	--	--	--

• Dimensions			• Style	• U.S.
D	W	H	Number	Price
9 1/8"	4 3/4"	1 13/16"	WBHS	\$33

Hanging Brackets

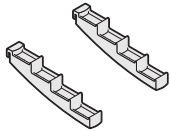

Standard Includes	Required to Specify
-------------------	---------------------

- Hanging brackets that support letter- and legal-size files: plastic

- 1 Style number
- 2 Plastic color number for hanging brackets:
 - 6000 Black
 - 6009 Arctic White
 - 6544 Frost
 - 6545 Amber
 - 6546 Rain

Related Products

- SlatRail
- Slatwall tiles

- ▶ Page 221
- ▶ Page 223

Specification Information				
---------------------------	--	--	--	--

• Dimensions			• Style	• U.S.
D	W	H	Number	Price
9 3/4"	1 1/2"	1 1/4"	WHB	\$33

Products on this page are Details, not Turnstone. They are included here to simplify your planning. Remember that Details has different pricing terms than Turnstone products.

 **For Canadian Pricing**
 Multiply U.S. Price by the Canadian price factor.
 ▶ See page 1 for details.

Letter Tray

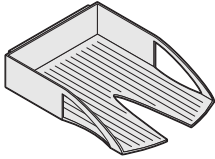

Standard Includes	Required to Specify
-------------------	---------------------

- | | |
|---|---|
| <ul style="list-style-type: none"> Letter tray that supports letter, legal, and A4 filing: plastic | <ul style="list-style-type: none"> 1 Style number 2 Plastic color number for letter tray: <ul style="list-style-type: none"> 6000 Black 6009 Arctic White 6544 Frost 6545 Amber 6546 Rain |
|---|---|

Related Products

- | | |
|--|--|
| <ul style="list-style-type: none"> SlatRail Slatwall tiles | <ul style="list-style-type: none"> ▶ Page 221 ▶ Page 223 |
|--|--|

Specification Information				
Dimensions			Style	U.S.
D	W	H	Number	Price

12½"	10"	2½"	WLTS	\$33
..

Media Holder X4/12



Standard Includes	Required to Specify
-------------------	---------------------

- | | |
|--|---|
| <ul style="list-style-type: none"> Media holder that provides storage for DVDs, CDs, disks, VHS tapes, and note pads: paint | <ul style="list-style-type: none"> 1 Style number 2 Paint color number for media holder: <ul style="list-style-type: none"> 0835 Black 7018 Pewter |
|--|---|

Related Products

- | | |
|--|--|
| <ul style="list-style-type: none"> SlatRail Slatwall tiles | <ul style="list-style-type: none"> ▶ Page 221 ▶ Page 223 |
|--|--|

Specification Information				
Dimensions			Style	U.S.
D	W	H	Number	Price

5"	5½"	3"	WMEDIA X4/12	\$33
..

Products on this page are Details, not Turnstone. They are included here to simplify your planning. Remember that Details has different pricing terms than Turnstone products.



For Canadian Pricing
 Multiply U.S. Price by the Canadian price factor.
 ▶ See page 1 for details.

X4/12 = Last order entry
 April 15, 2012

Telephone Caddy

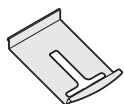

Standard Includes	Required to Specify
-------------------	---------------------

- | | |
|--|--|
| <ul style="list-style-type: none"> Telephone caddy that supports telephone off the worksurface: paint | <ul style="list-style-type: none"> 1 Style number 2 Paint color number for telephone caddy: <ul style="list-style-type: none"> 0835 Black 4750 Champagne 7018 Pewter |
|--|--|

Related Products

- | | |
|--|--|
| <ul style="list-style-type: none"> SlatRail Slatwall tiles | <ul style="list-style-type: none"> ▶ Page 221 ▶ Page 223 |
|--|--|

Specification Information				
---------------------------	--	--	--	--

Dimensions			Style Number	U.S. Price
D	W	H		
2"	8"	11"	WTCS	\$82

Personal Shelf

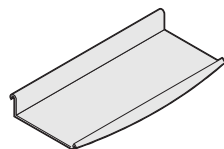

Standard Includes	Required to Specify
-------------------	---------------------

- | | |
|---|---|
| <ul style="list-style-type: none"> Personal shelf that provides storage and display for personal items and office tools: paint | <ul style="list-style-type: none"> 1 Style number 2 Paint color number for personal shelf: <ul style="list-style-type: none"> 0835 Black 4750 Champagne 7018 Pewter |
|---|---|

Related Products

- | | |
|--|--|
| <ul style="list-style-type: none"> SlatRail Slatwall tiles | <ul style="list-style-type: none"> ▶ Page 221 ▶ Page 223 |
|--|--|

Specification Information				
---------------------------	--	--	--	--

Dimensions			Style Number	U.S. Price
D	W	H		
7 1/8"	13 1/2"		WSPS	\$38

Products on this page are Details, not Turnstone. They are included here to simplify your planning. Remember that Details has different pricing terms than Turnstone products.



For Canadian Pricing
 Multiply U.S. Price by the Canadian price factor.
 ▶ See page 1 for details.

Pen/Pencil Cup

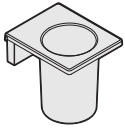

Standard Includes	Required to Specify
<ul style="list-style-type: none"> • Pen/pencil cup: plastic 	<ul style="list-style-type: none"> 1 Style number 2 Plastic color number for pen/pencil cup: <ul style="list-style-type: none"> 6000 Black 6009 Arctic White 6544 Frost 6545 Amber 6546 Rain

Related Products	
<ul style="list-style-type: none"> • SlatRail • Slatwall tiles 	<ul style="list-style-type: none"> ▶ Page 221 ▶ Page 223

Specification Information				
• Dimensions			• Style	• U.S.
D	W	H	Number	Price
4"	3 1/4"	3 5/8"	WPCS	\$33

Double Square Dish

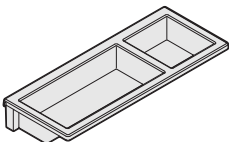

Standard Includes	Required to Specify
<ul style="list-style-type: none"> • Double square dish: plastic • Attachment bracket: paint 	<ul style="list-style-type: none"> 1 Style number 2 Plastic color number for square dish: <ul style="list-style-type: none"> 6000 Black 6009 Arctic White 6544 Frost 6545 Amber 6546 Rain

Related Products	
<ul style="list-style-type: none"> • SlatRail • Slatwall tiles 	<ul style="list-style-type: none"> ▶ Page 221 ▶ Page 223

Specification Information				
• Dimensions			• Style	• U.S.
D	W	H	Number	Price
4"	9 3/4"	1 1/2"	WSQS	\$33

Products on this page are Details, not Turnstone. They are included here to simplify your planning. Remember that Details has different pricing terms than Turnstone products.



For Canadian Pricing
 Multiply U.S. Price by the Canadian price factor.
 ▶ See page 1 for details.

Utility Hook



Standard Includes	Required to Specify
-------------------	---------------------

- | | |
|---|---|
| <ul style="list-style-type: none"> Utility hook: paint | <ul style="list-style-type: none"> 1 Style number 2 Paint color number for utility hook: <ul style="list-style-type: none"> 0835 Black 4750 Champagne 7018 Pewter |
|---|---|

Related Products

- | | |
|--|--|
| <ul style="list-style-type: none"> SlatRail Slatwall tiles | <ul style="list-style-type: none"> ▶ Page 221 ▶ Page 223 |
|--|--|

Specification Information				
Dimensions			Style	U.S.
D	W	H	Number	Price

13/4"	3 1/2"	2"	WHOOK	\$33
-------	--------	----	--------------	------

Simple Trolley



Standard Includes	Required to Specify
-------------------	---------------------

- | | |
|---|--|
| <ul style="list-style-type: none"> Trolley that stacks up to three file containers or stores file and project containers: 6000 Black plastic Casters: black | <ul style="list-style-type: none"> Style number |
|---|--|

Related Products

- | | |
|---|--|
| <ul style="list-style-type: none"> Project container File container | <ul style="list-style-type: none"> ▶ Page 238 ▶ Page 238 |
|---|--|

Specification Information				
Dimensions			Style	U.S.
D	W	H	Number	Price

14"	14"	2"	WTROL2	\$133
-----	-----	----	---------------	-------

Products on this page are Details, not Turnstone. They are included here to simplify your planning. Remember that Details has different pricing terms than Turnstone products.



For Canadian Pricing
 Multiply U.S. Price by the Canadian price factor.
 ▶ See page 1 for details.

Project Container



Standard Includes	Required to Specify
<ul style="list-style-type: none"> Project container that holds letter-size Pendaflex folder on inside rails: 6544 Frost 	Style number

Related Products	
<ul style="list-style-type: none"> SlatRail Slatwall tiles Simple trolley 	<ul style="list-style-type: none"> ▶ Page 221 ▶ Page 223 ▶ Page 237

Specification Information

• Dimensions			• Style	• U.S.
D	W	H	Number	Price
4 ³ / ₈ "	13 ¹ / ₈ "	10 ⁵ / ₁₆ "	WPROJ	\$49

File Container

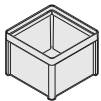

Standard Includes	Required to Specify
<ul style="list-style-type: none"> File container that holds letter-size Pendaflex folder on inside rails: 6544 Frost 	Style number

Related Products	
<ul style="list-style-type: none"> Simple trolley 	▶ Page 237

Specification Information

• Dimensions			• Style	• U.S.
D	W	H	Number	Price
13 ¹ / ₈ "	13 ¹ / ₈ "	10 ⁵ / ₁₆ "	WFILE	\$73

Products on this page are Details, not Turnstone. They are included here to simplify your planning. Remember that Details has different pricing terms than Turnstone products.



For Canadian Pricing
 Multiply U.S. Price by the Canadian price factor.
 ▶ See page 1 for details.

Personal Underline Task Light

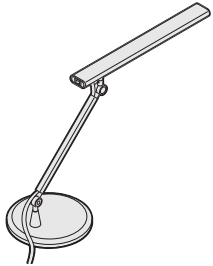

Standard Includes	Required to Specify
<ul style="list-style-type: none"> • Freestanding light that articulates at three pivot points for maximum adjustability: 7018 Pewter • End cap: 7018 Pewter • Head and arm: anodized aluminum • 8-watt compact fluorescent lamp • 8" cord: black 	<p>Style number</p>

Specification Information				
• Dimensions			• Style	• U.S.
D	W	H	Number	Price
4¾"	22"	20"	LUNDERF	\$362

Products on this page are Details, not Turnstone. They are included here to simplify your planning. Remember that Details has different pricing terms than Turnstone products.



For Canadian Pricing
 Multiply U.S. Price by the Canadian price factor.
 ▶ See page 1 for details.

AdjusTables Series 5

Laminate

Tip: AdjusTable Series 5 tables adjustable-height mechanism requires assembly and attachment to the worksurface.

Standard Includes	Required to Specify
<ul style="list-style-type: none"> • Worksurface: laminate • Plastic 3 mm edge profile on edge of worksurface: plastic • Push button height adjustability • 220 lbs load-bearing capacity • Attachment hardware 	<ol style="list-style-type: none"> 1 Style number 2 Laminate color number for worksurface: 2412 Natural Cherry 2511 Winter on Maple 2592 Blond on Maple 3 Edge color number for worksurface: 6034 Natural Cherry 6037 Winter on Maple 6038 Blond on Maple 4 Base color number for adjustable-height mechanism: 0835 Black 4799 Platinum Metallic

Options	U.S. Price	Required to Specify
Surface Materials High-Pressure Laminate worksurfaces <ul style="list-style-type: none"> • Open Line laminate 	+\$64 plus cost of laminate	▶ See <i>Surface Materials Reference Manual</i> .

Related Products	
<ul style="list-style-type: none"> • SlatRail • Slatwall tiles • Worktools 	<ul style="list-style-type: none"> ▶ Page 221 ▶ Page 223 ▶ Page 233

Specification Information				
Dimensions			Style	U.S.
D	W	H	Number	Base Price

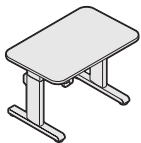

AdjusTable–Straight

23"	58"	25½"–52"	A5RQ582323U	\$1717

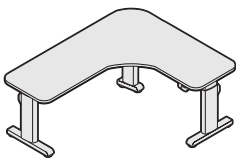

AdjusTable–90 Degree Corner

23"	58"RH,58"LH	25½"–52"	A5LQ58235823U	\$2650

Products on this page are Details, not Turnstone. They are included here to simplify your planning. Remember that Details has different pricing terms than Turnstone products.



For Canadian Pricing
 Multiply U.S. Price by the Canadian price factor.
 ▶ See page 1 for details.

Surface Materials

Surface Materials Listing	242
Tour Workspace	106
Campfire	133
Seating	196
Tables	208
Paint Matrix	246
Understanding Low-Pressure and High-Pressure Laminates	247
Specification Rule for Selectable Edge Band and Rules for High-Pressure Laminates	248
Turnstone Laminate Core Palette Matrix	249
Additional High-Pressure Laminates and Edge Bands	250
Recommended Edge Banding Finishes for Low-Pressure Laminate and High-Pressure Laminate Products	251
Edge Banding Color Defaults	252
Open Line Laminate	252
Wood Matrix	254
Plastic Matrix	255
Seating Upholstery Matrix	256
Seating Upholstery Matrix Turnstone Collection by Designtex	257
Fire Code Turnstone Seating Upholstery Matrix	258
Fire Code Seating Upholstery Turnstone Collection by Designtex	259
Understanding Customer's Own Material (COM)	260
Maintenance and Cleaning	262

Surface Materials Listing

Vertical Surface Fabrics

Steelcase Surfaces

Breccia [ⓔ]

Price Group A

R115 Cristal	R122 Sedge
R116 Marble	R123 Mica
R117 Grey Moss	R127 Bluestone
R121 Midas	

Boccie

Price Group 1

P200 New Rice	P205 New Mist
P201 New Almond	P206 New Plum
P202 New Nutmeg	P207 New Lichen
P203 New Camel	P208 New Spearmint
P204 New Opal	P209 New Sky

Buzz2

Price Group 1

5F01 Camel [ⓔ]	5G52 Barley
5F03 Tomato	5G53 Sunrise
5F04 Red [ⓔ]	5G54 Carrot
5F05 Burgundy	5G55 Pumpkin
5F06 Sky [ⓔ]	5G56 Timber
5F07 Blue	5G57 Rouge
5F08 Navy	5G58 Chocolate
5F10 Grape [ⓔ]	5G59 Meadow
5F11 Eggplant [ⓔ]	5G60 Ivy
5F15 Stone	5G61 Cyan
5F16 Grey	5G62 Atlantic
5F17 Black	5G63 Crocus
5G50 Dunegrass	5G64 Alpine
5G51 Sable	5G65 Tornado

[ⓔ] = Established

Seating Upholstery

Steelcase Surfaces

Tip: All Steelcase Textiles Price Group 3 upholstery requires an additional leadtime of two or more weeks.

Bo Peep

Price Group 5

5G66 Pita	5G77 Grapevine
5G67 Bone	5G78 Firefly
5G68 Safari	5G79 Artichoke
5G69 Brown Sugar	5G80 Serpent
5G70 Chocolate Chip	5G81 Carolina
5G71 Candlelight	5G82 Blue Bonnet
5G72 Honey Mustard	5G83 Nautical
5G73 Marmalade	5G84 Gravel
5G74 Picnic	5G85 Sharkskin
5G75 Pinot	5G86 Kohl
5G76 Bloom	

Boyne - 3280

Price Group 3

T925 Sand	T930 Peridot
T926 Bark	T931 Plum
T927 Bittersweet	T932 Comet
T928 Brick	T933 Boulder
T929 Navy	

Brisa

Price Group 6

BR01 Black Onyx	BR14 Pompeian Red
BR04 Truffle	BR15 Salsa
BR06 Ash	BR16 Cinnabar
BR07 Sage	BR17 Aztec
BR08 Celery	BR18 New Sand
BR09 Sterling Blue	BR19 Cream
BR10 Night Navy	BR20 White
BR11 Cambridge Blue	BR21 Moccasin
BR12 Abyss	BR22 Buckskin
BR13 Canyon	BR23 Prairie

Buzz2

Price Group 1

5F01 Camel [ⓔ]	5G52 Barley
5F03 Tomato	5G53 Sunrise
5F04 Red [ⓔ]	5G54 Carrot
5F05 Burgundy	5G55 Pumpkin
5F06 Sky [ⓔ]	5G56 Timber
5F07 Blue	5G57 Rouge
5F08 Navy	5G58 Chocolate
5F10 Grape [ⓔ]	5G59 Meadow
5F11 Eggplant [ⓔ]	5G60 Ivy
5F15 Stone	5G61 Cyan
5F16 Grey	5G62 Atlantic
5F17 Black	5G63 Crocus
5G50 Dunegrass	5G64 Alpine
5G51 Sable	5G65 Tornado

Cogent: Connect

Price Group 2

5S15 Coconut	5S26 Licorice
5S16 Turmeric	5S27 Malt
5S17 Tangerine	5S28 Root Beer
5S18 Scarlet	5S93 Blueprint
5S19 Concord	5S94 Lizard
5S20 Maya Blue	5S95 Sailor
5S21 Blue Jay	5S96 Quicksilver
5S22 Basil	5S97 Nugget
5S23 Wasabi	5S98 Canary
5S24 Nickel	5S99 Lipstick
5S25 Graphite	

Cogent: Geode Seating

Price Group 2

5S46 Bark	5S52 Pear
5S47 Coal	5S53 Berry
5S48 Smoke	5S54 Mandarin
5S49 Cobalt	5S55 Sunset
5S50 Ink	5S56 Citrus
5S51 Shamrock	5S57 Thunder

Cogent: Geode Vertical

Price Group 2

5S31 Pebble	5S38 Oyster
5S32 Canyon	5S39 Buff
5S33 Honey	5S40 Toast
5S34 Ice	5S41 Sesame
5S35 Slate	5S42 Ecru
5S36 Cement	5S43 Dove
5S37 Rock	

Cogent: Tides

Price Group 2

5S71 Butter	5S78 Clay
5S72 Snow	5S79 Hyacinth
5S73 Celery	5S80 Jet
5S74 Wicker	5S81 Doe
5S75 Pool	5S82 Boysenberry
5S76 Cloud	5S83 Night
5S77 Grass	

Cogent: Trails

Price Group 2

5S29 Bronzite	5S88 Quartz
5S30 Amethyst	5S89 Carnelian
5S84 Jasper	5S90 Tiger Eye
5S85 Agate	5S91 Travertine
5S86 Lapis	5S92 Topaz
5S87 Malachite	

E = Established

Cricket

Price Group 2

5A84 Plum	5A91 Spearmint
5A85 Camel	5A92 Sky
5A86 Charcoal	5A93 Midnight
5A87 Black	5A95 Ocean
5A90 Currant	5A96 Forest

Crosswalk

Price Group 2

5F48 Beech	5F53 Persimmon
5F49 Moon	5F54 Bittersweet
5F50 Berry	5F55 Midnight
5F51 Admiral Blue	5F56 Poppy
5F52 Moss	

Glen Arbor - 3283

Price Group 4

T945 Sand	T949 Plum
T946 Bark	T950 Comet
T947 Iris	T951 Boulder
T948 Green Stone	

Great Lakes - 3282

Price Group 3

T935 Sand	T939 Peridot
T936 Bark	T940 Mountain
T937 Iris	T941 Comet
T938 Green Stone	

Hampstead

Price Group 3

B351 Blue Green V4 E	B427 Turquoise
B359 Blue Blue Green V5 E	B428 Navy
B366 Blue Blue Violet V4 E	B429 Charcoal
B369 Blue Blue Violet V5 E	B430 Spa
B377 Violet V5 E	B431 Plum
B389 Red Red Violet V5 E	B432 Cocoa
B395 Grey V5 E	B433 Cork
B399 Black	B434 Stone
B406 Windflower E	B435 Metal
B413 Shale E	B436 Peridot
B423 Clementine	B437 Cactus
B424 Butter Cream	B438 Sycamore
B425 Iris	B439 Candy Apple
B426 Sapphire	

Surface Materials Listing, continued

Jacks

Price Group 1

5B61 Taupe	5B66 Plum
5B63 Camel	5B70 Midnight
5B64 Pewter	

Leland - 3281

Price Group 4

T955 Birch	T960 Apple
T956 Sand	T961 Wild Flower
T957 Frost	T962 Plum
T958 Comet	T963 Lake
T959 Bark	T964 Peridot

Link

Price Group 1

5A20 Burgundy	5A26 Purple
5A21 Rust	5A27 Black
5A23 Green	5A28 Ocean
5A24 Blue	5A29 Lichen
5A25 Navy	5A30 Chamois

Ludington - 3285

Price Group 3

T965 Putty	T972 Earth
T966 Dune	T973 Cobblestone
T967 Walnut	T974 Fog
T968 Cloud	T975 Midnight
T969 Chocolate	T976 Wood Smoke
T970 Red Clay	T977 Gray Quartz
T971 Canyon	T978 Ink

Nitelights

Price Group 2

5F58 Hazelnut	5F63 Moss
5F59 Burgundy	5F64 Sea
5F60 Cherry	5F65 Regal Blue
5F61 Earth	5F66 Stone
5F62 Shore	5F67 Moon

Playground

Price Group 1

5F28 Claret	5F33 Stone
5F29 Chile	5F34 Sky
5F30 Amber	5F35 Navy
5F31 Nut	5F36 Huckleberry
5F32 Blade	5F37 Charcoal

E = Established

Regis2

Price Group 2

5F18 Black	5F26 Cherry
5F24 Pacific	5F27 Navy

Saugatuck - 3284

Price Group 4

T915 White Pine	T920 Green Stone
T916 Bark	T921 Comet
T917 Sand	T922 Boulder
T918 Apple	T923 Plum
T919 Navy	

Spyder E

Price Group 2

5B00 Orchid	5B07 Sage
5B01 Foggy Night	5B09 Topaz
5B04 Peri	5B11 Currant
5B05 Merlot	5B12 Lichen
5B06 Dove	

Stand In

Price Group 2

5621 Sleet	5630 Apple
5622 Lunar	5631 Lava
5623 Cyclone	5632 Cayenne
5624 Eclipse	5633 Plantain
5625 Powder	5634 Parsley
5626 Chardonnay	5635 Scallion
5627 Graham	5636 Atlantis
5628 Sediment	5691 Orca
5629 Allspice	

Zoe2

Price Group 2

5C90 Eggplant	5C95 Rain
5C91 Aloe	5C96 Grey Flannel
5C92 Fiddle	5C97 Pebble
5C93 Patina	5C98 Cymbal
5C94 Peacock	5C99 Fiesta

Select Surfaces Designtex Seating Upholstery

For information on products within **Select Surfaces**, including accent paints and fabrics from Designtex, Maharam, and Pollack, please refer to the *Surface Materials Reference Manual* or visit Steelcase.com/selectsurfaces.

Please refer to the Steelcase COM database on Steelcase.com for the most current application information.

Leather

Steelcase Surfaces

Turnstone Leather

L304 Black
L305 Brown
T802 Black
T803 Port

Leather

Price Group Leather

L107 Black	L221 Rocky
L202 Dusk	L224 Plum
L203 Bottle	L500 Camel
L207 Mahogany	L503 Navy
L220 Soapstone	L507 Vineyard

Seating Vinyl

Steelcase Surfaces

Seating Vinyl

Price Group 1

5801 Topaz	5815 Seaside
5805 Foggy Night	5817 Pebble
5809 Black	5818 Spice
5810 Forest	5819 Thistle
5812 Navy	5820 Coffee
5813 Currant	5822 Iris
5814 Leaf	

Paint Matrix

For a surface materials listing of individual product lines, see *Surface Materials* at the end of each product chapter:

- ▶ Campfire, page 133
- ▶ Seating, page 196
- ▶ Tables, page 208
- ▶ Tour, page 106

	Bivi	Tour	Campfire Big Lamp base	Campfire Big Table trough	Screen mounting brackets	Slatwall screens
Price Group 1						
Textured Paint						
7207 Black	•	■	•	•	■	■
7225 Sand	•	■	•	•	•	■
7241 Arctic White	■	■	•	•	•	■
7243 Seagull	•	■	•	•	•	■
Price Group 2						
Smooth Metallic Paint						
4750 Champagne Metallic	•	■	•	•	•	■
4798 Sterling Metallic	•	■	•	•	■	■
4799 Platinum Metallic	■	■	■	■	■	■
Textured Metallic Paint						
7246 Midnight Metallic	■	■	■	•	•	■
Accessory Paint						
4140 Arctic White Gloss	•	•	■	•	•	•

Ships standard in 5-7 business days.

Tip: Paint finishes 4750 Champagne Metallic, 7225 Sand, 7241 Arctic White, 7243 Seagull, and 7246 Midnight Metallic are available in 15 days delivered on Smoke and Tour products only.

Legend

- = Not available
- = Available
- = Available with exceptions
- Ⓢ = Established
- ▶ See *Surface Materials* and Specifying pages.

Products that are missing from the matrix are not available with these surface materials.

Understanding Low-Pressure and High-Pressure Laminates

Understanding
Low-Pressure and High-
Pressure Laminates

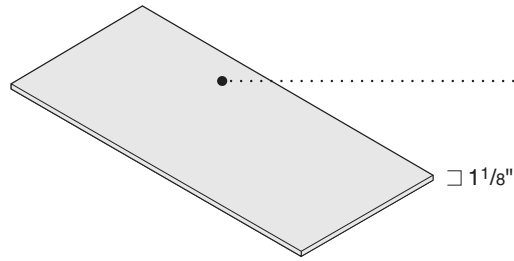

Standard workspaces on Jenny and Tour Workspace are available in Low-Pressure Laminates and High-Pressure Laminates.

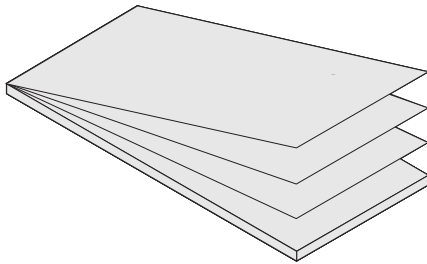

High-Pressure Laminates, or HPLs, are composed of multiple layers of crafted paper individually soaked in resin. There are 7-15 layers of paper combined to make the final sheet. The top layers are translucent melamine sheet and a decorative layer. The sheets are combined under heat and high pressure to form a single laminate sheet. The resulting sheet is then bonded under heat and high pressure to a wood core. HPLs are generally considered more durable than LPLs due to the extra layers of craft paper (backer) used in their creation. While they cost more, they are more durable. HPLs are generally used in higher traffic areas such as cafeterias and conference rooms. Generally, it is more cost effective to restrict their use to areas needing the added durability HPLs provide.

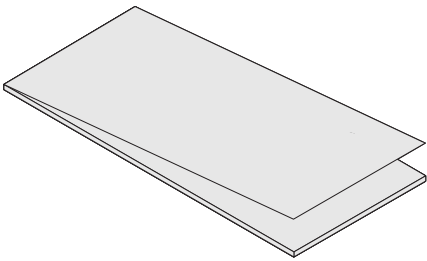

Low-Pressure Laminates, or LPLs, are created by dipping decorative crafted paper in melamine resin. The melamine dipped paper is then bonded to a wood core under heat and high-pressure. LPLs are generally suitable for use in lower impact areas. LPLs are generally used in vertical applications as well as tops for workstations and private offices. Generally, it is more cost effective to use LPLs when the performance of HPLs are not required.

Specification Rule for Selectable Edge Band and Rules for High-Pressure Laminates

Legend

- = Not available
- = Available

Selectable edge band (HPL)

Selectable Edge band Available

Jenny	
Tablet arms	■
End table	■
Coffee table	■
Tour Workspace	
Counter	•
Counter infills	•
Counter tops	•
Shelves	■
Worksurfaces	■
Worksurface supports	•
Modesty panels	•
Screens	•
HV cabinets	•
Bookcases	•
Pile files	•

Specification Rule for Selectable Edge band

When specifying tops, you are required to select an edge band color.

▶ See *Recommended Edge Banding Finishes for Low-Pressure Laminate and High-Pressure Laminate Products*, page 251.

You could select an edge band for a worksurface that is different than the default for the rest of the product in the work station (i.e. upper storage, towers, etc.)

Rules for High-Pressure Laminates only

1. HPL can be used on worksurfaces and shelves for Tour.
2. HPL can also be used on these non-standard worksurfaces: Jenny tablet arms and tables.

Turnstone Laminate Core Palette Matrix

Turnstone Laminate Core
Palette Matrix

Applies to Tour, Jenny, and Campfire
Ships standard in 5-7 business days

For a surface materials listing of individual product lines, see *Surface Materials* at the end of each product chapter:

- ▶ Campfire, page 133
- ▶ Seating, page 196
- ▶ Tables, page 208
- ▶ Tour, page 106

	LPL & HPL Available:		Exceptions:					
	Tour worksurfaces and shelves	Jenny tables and tablet arms	Bivi	Tour vertical surfaces	Tour countertops	Campfire Big Table and Storage Cabinets	Campfire Paper Table	
Low-Pressure Laminate (LPL)								
247L Black Version 2 LPL	•	■	•	•	•	•	•	
25L1 Winter on Maple LPL	■	■	•	■	■	•	•	
25L5 Virginia Walnut LPL	■	■	■	■	■	■	■	
25L6 Blackwood LPL	■	■	■	■	■	■	■	
25L8 Clear Walnut LPL	■	■	■	■	■	■	■	
25L9 Warm Oak LPL	■	■	■	■	■	■	■	
262L Marbled Maple LPL	•	■	•	•	•	•	•	
264L Chocolate Walnut LPL	•	■	•	•	•	•	•	
267L Marbled Cherry Version 2 LPL	•	■	•	•	•	•	•	
26L1 Natural Cherry Version 2 LPL	■	■	•	■	■	■	•	
2L03 Brushed Silver LPL	•	■	•	•	•	•	•	
2L30 Arctic White LPL	■	■	•	■	■	■	•	
2L50 Vanadium Fiber LPL	•	■	•	•	•	•	•	
2L52 Tungsten Fiber LPL	•	■	•	•	•	•	•	
2L83 Seagull LPL	•	■	•	•	•	•	•	
2L85 Dune LPL	•	■	•	•	•	•	•	
High-Pressure Laminate (HPL)								
2406 Clear Cherry HPL	■	■	•	•	•	•	•	
2412 Natural Cherry Version 2 HPL	■	■	•	•	•	•	•	
2503 Brushed Silver HPL	■	■	•	•	•	•	•	
2511 Winter on Maple HPL	■	■	•	•	•	•	•	
2535 Virginia Walnut HPL	■	■	•	•	•	•	•	
2536 Blackwood HPL	■	■	•	•	•	•	•	
2538 Clear Walnut HPL	■	■	•	•	•	•	•	
2539 Warm Oak HPL	■	■	•	•	•	•	•	
2612 Marbled Maple HPL	■	■	•	•	•	•	•	
2614 Chocolate Walnut HPL	■	■	•	•	•	•	•	
2615 Marbled Cherry Version 2 HPL	■	■	•	•	•	•	•	
2730 Arctic White HPL	■	■	•	•	•	•	•	
2746 Black HPL	■	■	•	•	•	•	•	
2850 Vanadium Fiber HPL	■	■	•	•	•	•	•	
2852 Tungsten Fiber HPL	■	■	•	•	•	•	•	
2883 Seagull HPL	■	■	•	•	•	•	•	
2885 Dune HPL	■	■	•	•	•	•	•	

Legend

- = Not available
- = Available
- = Available with exceptions
- ▶ See *Surface Materials* and Specifying pages.

Products that are missing from the matrix are not available with these surface materials.

Color, stability, and lighting
Surface materials are formulated to maintain compatibility under horizon light, daylight, and cool white light. As a precaution, always select colors and materials under the specific type of lighting they will receive in actual office use. Particular care should be used with high intensity discharge light, which can adversely affect color compatibility. The swatch material on this card is provided as a color guideline. There may be variations in color, texture, and finish between this sample and the actual product.

Additional High-Pressure Laminates and Edge Bands

For use on: Jenny and Tour

High-Pressure Laminate Color	Recommended Edge Band
2422 Medium Cherry	6036 Medium Cherry
2592 Blonde on Maple	6038 Blonde On Maple
2714 Natural Walnut	6041 Natural Walnut
2820 Coffee Speckle	6631 Cream
2822 Woodrose Speckle	6635 Dawn E
2823 Driftwood Speckle	6631 Cream
2824 Smoke Speckle	6636 Mist
2825 Vanadium Speckle	6619 Ice E
2851 Rhyme Fiber	6631 Cream
2854 Vellum Fiber	6655 Warm White
2859 Novell Fiber	6001 Coffee
2860 Granite Fiber	6000 Black
2861 Coconut Fiber	6654 Sand
2862 Stucco Fiber	6053 Seagull
2870 Blonde Bronze Patina	6654 Sand
2871 Blackened Bronze Patina	6615 Grey V5
2873 Instant Iron Patina	6615 Grey V5
2884 Milk	6052 Milk
2920 Marl Micro	6053 Seagull
2921 Gypsum Micro	6654 Sand
2922 Clay Micro	6654 Sand
2923 Shadow Micro	6249 Platinum Solid
2900 Open Line laminate	User Must Specify

Available Edge Bands

6000 Black
6001 Coffee
6009 Arctic White
6034 Natural Cherry
6036 Medium Cherry
6037 Winter On Maple
6038 Blonde On Maple
6041 Natural Walnut
6052 Milk
6053 Seagull
6234 Clear Cherry
6249 Platinum Solid
6615 Grey V5
6619 Ice E
6631 Cream
6635 Dawn E
6636 Mist
6654 Sand
6655 Warm White
6676 Marbled Maple
6677 Chocolate Walnut
6678 Marbled Cherry
6689 Brushed Silver
6697 Fog

Ships standard in 5-7 business days.

E = Established

Recommended Edge Banding Finishes for Low-Pressure Laminate and High-Pressure Laminate Products

Recommended Edge Banding Finishes for Low-Pressure Laminate and High-Pressure Laminate Products

Available on Jenny and Tour

Plastic Color

6000	Black	6234	Clear Cherry	6654	Sand
6001	Coffee	6237	Clear Maple	6655	Warm White
6009	Arctic White	6242	Virginia Walnut	6676	Marbled Maple
6034	Natural Cherry	6243	Blackwood	6677	Chocolate Walnut
6036	Medium Cherry	6245	Clear Walnut	6678	Marbled Cherry
6037	Winter on Maple	6246	Warm Oak	6689	Brushed Silver
6038	Blonde on Maple	6249	Platinum Solid	6697	Fog
6041	Natural Walnut	6615	Grey V5		
6045	Medium Mahogany on Walnut	6619	Ice E		
6052	Milk	6631	Cream		
6053	Seagull	6635	Dawn E		
6231	Graphite Walnut	6636	Mist		

Low-Pressure Laminate Color

Recommended Edge Band

25L1	Winter on Maple LPL	6037	Winter On Maple
25L5	Virginia Walnut LPL	6242	Virginia Walnut
25L6	Blackwood LPL	6243	Blackwood
25L8	Clear Walnut LPL	6245	Clear Walnut
25L9	Warm Oak LPL	6246	Warm Oak
26L1	Natural Cherry Version 2 LPL	6034	Natural Cherry
2L30	Arctic White LPL	6009	Arctic White

High-Pressure Laminate Color

Recommended Edge Band

2412	Natural Cherry HPL	6034	Natural Cherry
2511	Winter on Maple HPL	6037	Winter On Maple
2535	Virginia Walnut HPL	6242	Virginia Walnut
2536	Blackwood HPL	6243	Blackwood
2538	Clear Walnut HPL	6245	Clear Walnut
2539	Warm Oak HPL	6246	Warm Oak
2730	Arctic White HPL	6009	Arctic White

E = Established

Edge Banding Color Defaults

alight lounge

Wood

Plastic edge plastic color on worksurfaces is a default and cannot be specified. It is determined by the wood color specified.

Wood Color	Default Veneer Edge Color
3412 Natural Cherry E	Natural Cherry
3522 Clear Maple	Clear Maple
3762 Dark Walnut	Dark Walnut

Tip: Steelcase's transition to PVC-free edge banding is beginning in July 2008. Check in 2.steelcase.com to see which edge colors and profiles have switched to PVC-free plastic.

E = Established

The Open Line Laminate (OLL) Program offers the opportunity for customers to select laminates that are not offered through the standard Turnstone laminate offering for use on Turnstone products.

The following products are available using the OLL process: Jenny and Tour.

An additional feature of the Open Line Laminate Program is the ability to order different edge colors (other than the default edge color specified in the specification guide) for use with standard Turnstone laminates. See below for pricing information for this application.

Application Testing/Approval

To order an Open Line laminate on a Turnstone product, first confirm that the selected laminate has been tested and approved for use on a specific product by checking the custom surface materials Web site at www.steelcase.com/com.

If the laminate is **approved**, you may continue the ordering process. If the laminate has **failed** to meet testing and approval standards, you must choose another laminate. If the laminate is **not listed**, Turnstone laminate.

To have your material tested, send the following materials to Steelcase:

- One (1) 4' x 8' sheet of high-pressure decorative laminate that is vertical grade, post formable (VGP), and 0.028" (0.7 mm) thick
- A completed Open Line Laminate Testing Request Form

Access the Web site at www.steelcase.com.

Under surface materials, select custom surface materials and the Open Line laminate option. The test request form can be found under "create test request".

Note: All information on the form is required in order to complete testing.

**Send your laminate materials to:
Steelcase Inc.
Attn: OLL Testing Department
6100 East Paris Avenue
Caledonia, MI 49316**

Submit Request

Use the electronic Open Line Laminate Testing Request Form found on the Steelcase custom surface materials Web site under the "How To Test" tab, or fax a copy of the form to 616.698.4700.

Test Results

Test results will be returned by fax or e-mail in four working days from receipt of laminate and form.

Not all testing is based on actual production conditions. Because some laminates vary in fabrication, Turnstone reserves the right to reject any non-standard laminates that do not meet manufacturing requirements, even though the sample passed initial testing.

E = Established

Application Direction

Open Line laminates are applied to products in the Turnstone standard application direction. For directional laminates, each individual specification guide shows the standard application direction for that product. Application in other than standard direction must be processed through Specials Engineering.

Open Line Laminates Square Footage Requirements

To determine how much laminate you will need, access the calculator found on the Steelcase custom surface materials Web site at www.steelcase.com/com. Material estimates will vary depending on the following items:

- Laminate properties
- Laminate directionality
- Sheet sizes offered by the vendor
- Edge type
- Product style number
- Quantity of products being manufactured

Open Line Laminates Pricing

Open Line laminates are available at an additional \$64 (U.S.) per surface, plus the cost of the laminate. If you select Formica, Nevamar, Pionite, or WilsonArt laminate, the cost of the laminate is \$1.10 (U.S.) per square foot. (Non-Discountable)

Example:
4' x 8' sheet = 32 square feet
32 square feet x \$1.10 = \$35.20 (U.S.)
per sheet

Laminate cost may vary for other suppliers. Please contact the OLL consultant at 616.475.2426 for pricing. The cost of the laminate will be added to your invoice as a separate line on the acknowledgement.

There are no additional charges beyond the initial \$64 U.S. list to obtain **different edge colors with Turnstone standard laminates.**

Special engineering products using the Open Line laminate process will be priced at \$64 (U.S. list) per surface, plus the cost of the laminate. If you select Formica, Nevamar, Pionite, or Wilson Art laminate to be used on Special Engineering products, the cost of the laminate is \$45 (U.S.) per surface. (Non-Discountable).

There are no additional charges beyond the initial \$64 (U.S. list) and any applicable Special Engineering charges to obtain different edge colors with Turnstone standard laminates.

How to Order

Once you have confirmed that the laminate you've selected has been tested and approved, you are ready to place your order.

To order an Open Line laminate on a Turnstone product:

- Mark the purchase order with the
 - Laminate manufacturer,
 - Laminate number, and
 - Laminate description
- Use the appropriate Open Line laminate number (2900).
- Use the appropriate edge band color number to indicate the edge color requirements.

The order is subject to the manufacturer's minimum order requirements. Please contact the laminate supplier for verification of minimum order requirements before ordering.

Turnstone to Purchase Service

The Open Line Laminate Program includes a service to purchase approved Open Line laminates for use on Turnstone products.

Turnstone will facilitate the ordering, scheduling, and shipment of Open Line laminates directly from the suppliers and will apply it to the product.

Turnstone is the only party that may purchase material. The only time the customer purchases material is for testing purposes.

Additional lead times apply to all orders specifying Open Line laminates.

Turnstone is not responsible for overages and will not issue credit for any differences between the estimated amount provided and the actual amount ordered and acknowledged.

Laminate suppliers require laminate to be purchased in full sheets. Turnstone will determine how many sheets are needed and order appropriately.

Contact

For Open Line laminate test results, Application Test Request Form, or square foot requirements, visit the custom surface materials Web site at www.steelcase.com/com.

For additional information call
1.800.TURNSTONE

Wood Matrix

For a surface materials listing of individual product lines, see *Surface Materials* at the end of each product chapter:

- ▶ Campfire, page 133
- ▶ Seating, page 196

		Wood Finish			
		3412 Natural Cherry	3522 Clear Maple	3611 Natural Oak	3762 Dark Walnut
alight lounge	Maple legs and table base	■	■	•	■
Campfire personal table	Table base	•	•	■	•
Jenny	Maple legs and arm	■	■	•	■

Tip: The wood used in the construction of chairs is either maple or European beech. Wood finishes will match, but will not have the same natural grain.

Note: Wood color 3522 is a clear coat. Therefore, the natural variations in wood (maple or European beech) will be visible.

Note: Due to natural variations in wood, finished products may vary in color, texture and grain.

Legend

- = Not available
- = Available
- = Available with exceptions
- ⓪ = Established
- ▶ See *Surface Materials* and Specifying pages.

For a surface materials listing of individual product lines, see *Surface Materials* at the end of each product chapter:
 ▶ Seating, page 196
 ▶ Tables, page 208

	Scoop	Slatwall Screens	Sweeper Martini table
627T Black	•	•	■
628T Natural	•	•	■
631T Dark Grey	•	•	■
6505 Frosted White	•	■	•
6506 Frosted Blue	•	■	•
6507 Frosted Green	•	■	•
6618 White	■	•	•
6682 Cobblestone	■	•	•

Legend

- = Not available
- = Available
- = Available with exceptions
- Ⓢ = Established
- ▶ See *Surface Materials* and Specifying pages.

Products that are missing from the matrix are not available with these surface materials.

Seating Upholstery Matrix

Turnstone

	Price Group	alight Lounge Series	Campfire Big Lamp	Campfire Big Lounge	cobi Select	Crushed Can	Hoodie	Jenny Lounge	Lincoln Lounge	Reply Select - Mesh Back	Rumble Seat	Scoop - Upholstered Seat	Tour - Lateral File Cushion	Uno Select
Bo Peep	5	■	•	■	•	■	•	■	•	•	•	■	■	•
Brisa	6	■	•	■	•	■	•	■	•	•	•	■	■	•
Buzz2	1	■	•	■	•	■	•	■	•	■	•	■	■	•
Cogent: Connect	2	■	■	■	■	■	■	■	•	•	■	■	■	■
Cogent: Geode Seating	2	■	•	■	•	■	•	■	•	•	•	■	■	•
Cogent: Geode Vertical	2	■	•	■	•	■	•	■	•	•	•	■	■	•
Cogent: Tides	3	■	•	•	•	■	•	■	•	•	•	■	■	•
Cogent: Trails	2	■	•	■	•	■	•	■	•	•	•	■	■	•
Cricket	2	■	•	■	•	■	•	■	•	•	•	■	■	•
Crosswalk	2	■	•	■	•	■	•	■	•	•	•	■	■	•
Hampstead	3	■	•	■	•	■	•	■	•	•	•	■	■	•
Jacks	1	■	•	■	•	■	•	■	•	•	•	■	■	•
Turnstone Leather	NA	•	•	•	•	•	•	•	•	•	•	•	•	•
Steelcase Leather	L	•	•	•	•	•	•	■	•	•	•	•	■	•
Mastrotto Leather	NA	•	•	•	•	•	•	■	•	•	•	•	•	•
Link	1	■	•	■	•	■	•	■	•	•	•	■	■	•
Nitelights	2	■	•	■	•	■	•	■	•	•	•	■	■	•
Playground	1	■	•	■	•	■	•	■	•	•	•	■	■	•
Regis2	2	■	■	■	•	■	•	■	•	•	•	■	■	•
Seating Vinyl	1	■	•	■	•	■	•	■	•	•	•	■	■	•
Spyder [ⓔ]	2	■	•	■	•	■	•	■	•	•	•	■	■	•
Stand In	2	■	•	■	•	■	•	■	•	•	•	■	■	•
Zoe2	2	■	•	■	•	■	•	■	•	•	•	■	■	•

Ships standard in 5-7 business days.

Tip: Brisa is available in 15 days delivered only.

Legend

- = Not available
- = Available
- = Available with exceptions
- = COM approved
- ⓔ = Established
- ▶ See *Surface Materials* and *Specifying* pages.

Products that are missing from the matrix are not available with these surface materials.

Seating Upholstery Matrix Turnstone Collection by Designtex

Seating Upholstery Matrix
Turnstone Collection by
Designtex

	Price Group	alight Lounge Series	Campfire Big Lamp	Campfire Big Lounge	cobi Select	Crushed Can	Hoodie	Jenny Lounge	Lincoln Lounge	Reply Select - Mesh Back	Rumble Seat	Scoop - Upholstered Seat	Tour - Lateral File Cushion	Uno Select
Boyne	3	■	•	■	•	■	•	■	•	•	•	■	■	•
Glen Arbor	4	■	•	■	•	■	•	■	•	•	•	■	■	•
Great Lakes	3	■	•	■	•	■	•	■	•	•	•	■	■	•
Leland	4	■	•	■	•	■	•	■	•	•	•	■	■	•
Ludington	2	■	•	■	•	■	•	■	•	•	•	■	■	•
Saugatuck	4	■	•	■	•	■	•	■	•	•	•	■	■	•

Ships standard in 5-7 business days.

Legend

- = Not available
- = Available
- = Available with exceptions
- ▣ = COM approved
- ▶ See *Surface Materials* and *Specifying* pages.

Fire Code Turnstone Seating Upholstery Matrix

Cal TB 133 is the highest flame retardance rating available on Turnstone brand seating products. It means that an article is manufactured for use in public occupancies and meets the flammability requirements of California Bureau of Home Furnishings Technical Bulletin, etc.

All Turnstone upholstery fabrics pass Cal. 116 and 117 requirements.

	Price Group	alight Lounge	Campfire Big Lamp	Campfire Big Lounge	cobi Select	Crushed Can	Hoodie	Jenny Lounge	Lincoln Lounge	Reply Select - Mesh Back	Rumble Seat	Scoop - Upholstered Seat	Tour - Lateral File Cushion	Uno Select
Bo Peep	5	■	●	■	●	●	●	■	●	●	●	●	●	●
Brisa	6	●	●	●	●	●	●	●	●	●	●	●	●	●
Buzz2	1	■	●	■	●	●	●	■	●	ⓔ	●	●	●	●
Cogent: Connect	2	■	ⓔ	■	ⓔ	●	ⓔ	■	●	●	ⓔ	●	●	ⓔ
Cogent: Geode Seating	2	●	●	■	●	●	●	●	●	●	●	●	●	●
Cogent: Geode Vertical	2	●	●	■	●	●	●	●	●	●	●	●	●	●
Cogent: Tides	3	■	●	●	●	●	●	■	●	●	●	●	●	●
Cogent: Trails	2	■	●	■	●	●	●	■	●	●	●	●	●	●
Cricket	2	■	●	■	●	●	●	■	●	●	●	●	●	●
Crosswalk	2	■	●	■	●	●	●	■	●	●	●	●	●	●
Hampstead	3	■	●	■	●	●	●	■	●	●	●	●	●	●
Jacks	1	■	●	■	●	●	●	■	●	●	●	●	●	●
Turnstone Leather	NA	●	●	●	●	●	●	●	●	●	●	●	●	●
Steelcase Leather	L	●	●	●	●	●	●	ⓔ	●	●	●	●	●	●
Mastrotto Leather	NA	●	●	●	●	●	●	●	●	●	●	●	●	●
Link	1	■	●	■	●	●	●	■	●	●	●	●	●	●
Nitelights	2	■	●	■	●	●	●	■	●	●	●	●	●	●
Playground	1	■	●	■	●	●	●	■	●	●	●	●	●	●
Regis2	2	■	ⓔ	■	ⓔ	●	●	■	●	●	●	●	●	●
Seating Vinyl	1	■	●	●	●	●	●	■	●	●	●	●	●	●
Spyder ⓔ	2	■	●	■	●	●	●	■	●	●	●	●	●	●
Stand In	2	ⓔ	●	●	●	●	●	ⓔ	●	●	●	●	●	●
Zoe2	2	■	●	■	●	●	●	■	●	●	●	●	●	●

Ships standard in 5-7 business days.

Legend

- = Not available
- = Available
- ⓔ = Available with exceptions
- ⓔ = Untested
- ⓔ = Established
- ▶ See *Surface Materials* and Specifying pages

Fire Code Seating Upholstery Turnstone Collection by Designtex

Fire Code Seating
Upholstery Turnstone
Collection by Designtex

	Price Group	alight Lounge	Campfire Big Lamp	Campfire Big Lounge	cobi Select	Crushed Can	Hoodie	Jenny Lounge	Lincoln Lounge	Reply Select - Mesh Back	Rumble Seat	Scoop - Upholstered Seat	Tour - Lateral File Cushion	Uno Select
Boyne	3	•	•	◻	•	•	•	◻	•	•	•	•	•	•
Glen Arbor	4	•	•	◻	•	•	•	◻	•	•	•	•	•	•
Great Lakes	3	■	•	■	•	•	•	■	•	•	•	•	•	•
Leland	4	■	•	■	•	•	•	■	•	•	•	•	•	•
Ludington	2	•	•	•	•	•	•	◻	•	•	•	•	•	•
Saugatuck	4	■	•	■	•	•	•	■	•	•	•	•	•	•

Ships standard in 5-7 business days.

Legend

- = Not available
- = Available
- ◻ = Available with exceptions
- ◻ = Untested
- ▶ See *Surface Materials* and *Specifying* pages

Understanding Customer's Own Material (COM)

The Customer's Own Material (COM) program allows customers to select textiles that are not offered through the standard Surface Materials program for use on Turnstone products.

The COM process consists of seven steps: COM Web Site, Testing/Approval, Steelcase to Purchase Service, Pricing, Cutting Direction, Yardage Requirements, and the Purchase Orders.

COM Web Site

- COM Web site features application test results for all COM, Designtex Graded-In, Options Collection and Classics Collection fabrics. The Web site allows you to calculate yardage requirements for most Turnstone seating and systems products.
- Access the COM Web site at: www.steelcase.com. 1.888.STEELCASE (1.888.783.3522) or send an e-mail to lineone@steelcase.com.

Application Testing/Approval

- Confirm that the selected COM has been tested and approved for application on a specific product by checking the COM Web site at: www.steelcase.com.

COM Application Testing or "approved for application" means the COM fabric has been reviewed for manufacturability using the standard manufacturing techniques to achieve acceptable appearance per Steelcase quality standards.

COM fabric performance, including durability, pilling, color fastness, stretch, splitting, fraying, etc. is not tested by Steelcase. Therefore, COMs are not covered by the Steelcase Warranty. Each COM vendor is responsible for all warranty claims related to fabric performance.

Steelcase reserves the right to reject or reverse any COM approval that does not meet the manufacturing requirements in actual production. COM approval may be rejected or reversed because not all application testing is based on actual production conditions and because some materials vary in fabrication.

- If the COM is approved, you may continue the order process.
- If the COM has failed, you must reselect a fabric.
- If the COM is not listed, that means Steelcase has not tested that fabric on our products.
Helpful hint: Seating vinyl and leather do not require testing. Customer's own leather is available on Jenny Lounge seating. Customer's own vinyl is available on all seating products that accept Steelcase standard vinyl.

- If your material has not been tested, then send yardage (4.5 yards for seating, 2 yards for vertical surfaces) and submit a completed COM Application Testing Request form to:
Steelcase Inc.
Attn: COM Testing
Door 305
4060 Eastern Avenue
Grand Rapids, MI 49508
- To ensure rapid processing, please use the electronic COM Application Testing Request form found on the COM Web site under the "How To Test" tab **or** fax a copy of the COM Testing Request form from the *Surface Materials Reference Manual* to 616.698.4700. **All information on the form is required in order to complete testing. COM tests cannot be performed if information is incomplete. Contact your requested fabric vendor for any missing information.**
- Test results will be returned (by fax or e-mail) in four working days from receipt of fabric and completed form.

COM materials that are approved for application to panel systems might require UL approval after application test approval. UL approval does involve fees and extended lead times.

All vertical surface COMs tested and approved with a content of 100% polyester meet a minimum of class C/UL1286. If class A or B fire rating is indicated, a burn test must be performed. All vertical surface COMs with a blended fabric construction require a UL burn test. For further UL information, contact a COM Consultant at 616.475.2426.

Tip: Jenny Lounge products have a relaxed appearance. With some COMs they may show soft comfort wrinkles upon use.

Steelcase to Purchase Service

The COM program also includes a service to purchase approved COM for our customers for use on Turnstone products. Steelcase will facilitate the ordering, scheduling and shipment of COM directly from the suppliers. There are no additional charges for this service.

Steelcase is the only party that may purchase COM for all Turnstone products.

In some instances, not all colors in a fabric family are approved. You will be informed of these instances before Steelcase purchases the fabric.

If for some reason the fabric must be ordered directly from the supplier, contact your Steelcase Solutions Fulfillment Team Representative for approval and instructions prior to purchase. The only time the customer can purchase fabric is for testing.

COM Pricing

- Confirm COM is tested and approved.
- Use the COM or COL (Customer's Own Leather) price group found under Surface Materials Options within each product spec guide.
- Calculate yardage required by using the COM Calculator found on the COM Web site at www.steelcase.com 1.888.STEELCASE (1.888.783.3522) or send an e-mail to lineone@steelcase.com.
Helpful tip: Fabric width, repeat and product quantity and style number are required in order to calculate yardage accurately.
- Add the cost of the fabric to the COM or COL price group.
- The cost of the COM will be shown as a separate line on the acknowledgement.

COM vendors require fabric purchases in half or full yard increments. Therefore, Steelcase will round all final yardage calculations to the half yard.

COL (Customer's Own Leather) is calculated by the square foot, but purchased in hide. The customer is responsible for purchasing the minimum hide requirement.

Base price of chair includes standard fabrics. Steelcase will not allow credit or deduct the cost of the standard fabric when a COM fabric is selected in its place.

Steelcase cannot be held responsible for costs incurred when a COM supplier ships a COM fabric that does not meet Steelcase application standards or for costs incurred for late deliveries when a COM supplier commits to shipping a COM fabric for manufacturing by a specific date and misses that date.

COM Warranty

Steelcase standard warranty does not apply to Designtex or any other COM vendor's fabric.

Designtex and other COM suppliers are responsible for color consistency within commercial tolerances, abrasion resistance, UV stability, and resistance to soiling and perspiration. These fabrics or vinyls are subject to policies regarding appearance, behavior, and durability that have been established by the fabric supplier. The customer's remedy for a fabric defect is limited to the replacement of the fabric by the supplier. Durability, performance, and fabric defects of COM fabrics are not guaranteed by Steelcase.

Cutting Direction

SEATING:

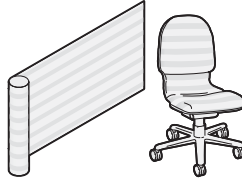

Warp horizontal



Warp vertical

• **Dealers must specify fabric application direction on all COM orders.**

• COMs for seating are most often applied in the warp vertical (downroll, woven way) direction. Some exceptions include patterns with stripes, fabrics that are sampled in the warp horizontal (railroad, across roll) direction, and solid vinyls.

▶ See Cutting Direction Guidelines in the *Surface Materials Reference Manual* for more information.

VERTICAL SURFACES:

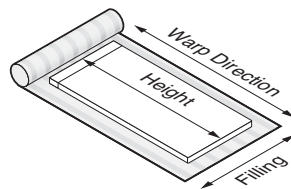

Warp vertical

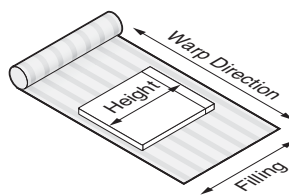

Warp horizontal

• **Dealers must specify fabric application direction on all COM orders.**

• The cutting direction of COMs on vertical surfaces varies by product and sometimes by style number. Please check the COM Web site for the approved cutting direction for your particular COM.

▶ See Cutting Direction Guidelines in the *Surface Materials Reference Manual* for more information.

Steelcase cannot guarantee pattern repeat match from product to product. Steelcase also cannot guarantee pattern repeat match within each product listed. (i.e., seat and back, arms to back, etc.)

COM Yardage Requirements

- For the most accurate yardage requirements, visit the Calculator found on the COM Web site or call 1.888.STEELCASE (1.888.783.3522) or send an e-mail to lineone@steelcase.com.
- The Calculator on the COM Web site provides the same yardage requirements used by Steelcase purchasing.

Yardage requirements will change depending on:

- width of fabric
- fabric repeat
- cutting direction
- product style number
- quantity of products being manufactured

• COM vinyl requires upholstery in the railroad cutting direction. Please visit our Web site or call 1.888.STEELCASE (1.888.783.3522) or send an e-mail to lineone@steelcase.com for yardage requirements.

• Certain fabric treatments and backings require additional yardage or yardage minimums. Please contact the supplier for specific information.

• COM fabric vendors require fabric purchases in half- or full-yard increments, and the Steelcase COM calculator will automatically round all final yardage calculations to the half yard.

• Steelcase is the only party who may purchase COMs.

Maintenance and Cleaning

Inspecting and cleaning. Have your chair's upholstery, finishes, controls, base, and other moving parts inspected and cleaned at least once a year.

Cleaning painted and plastic surfaces. Finishes should be cleaned with water and/or a non-abrasive cleaner (such as Formula 409® and Fantastik®).

Maintaining upholstery. Use a vacuum cleaner for regular cleaning. Periodic professional dry cleaning is recommended. Do not steam clean.

Removing excess stains or heavy soil. Soak up excess stain with a cloth. Do not dry the stain completely or it may set. For most water-soluble stains (coffee, fruit juice, washable ink), use an upholstery cleaning solution (such as Bissell® upholstery shampoo or Guardsman Fabri-Kleen® products) and follow directions on package. For oil-borne stains, use a dry cleaning solution at room temperature (never hot) and let solution work into the stain. Use quick, light strokes to brush the stain with a soft bristle brush. Work from outside toward the center to prevent rings. Soak up remaining dry cleaning solution, then sponge the fabric with cool water. Let fabric dry completely; then vacuum thoroughly. If stain is still visible, repeat procedure. Several light applications of cleaning solution are more effective and less damaging than one heavy application.

Formula 409 is a registered trademark of Clorox company. Fantastik is a registered trademark of Dow Consumer Products, Inc. Fabri-Kleen is a registered trademark of Guardsman Chemical. All other marks are marks of their respective owners.

Resources

Lock and Keying Options

Tour and Campfire

264

Style Number Index

266

Lock and Keying Options

Tour and Campfire

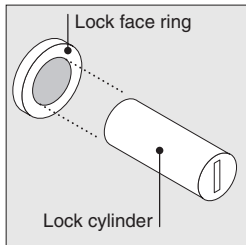

Front-removable lock cylinders can be installed or removed in the field with a special tool. This feature allows you to field install lock cylinders after the furniture is installed.

All locks are designated with key numbers. You can specify a key number; however, if you don't specify a key number, the locks in your order will be keyed random.

Two types of locks are available — the standard keying system (FR series) and the master keying system (XF series). All the locks in the XF series can be opened with a single master key.

Standard Keying

All products are standard keyed random.

Step 1

Furniture will be shipped with a plastic shipping plug. Specify lock cylinder and keying options separately. Only products with factory-installed lock mechanisms can accept lock cylinders in the field.

Tip: Be sure to specify a lock color number (9201 Polished Chrome or 9250 Ember Chrome) for the lock face ring.

Step 2

Order enough lock cylinders to fill each lock location. You must also order a lock tool.

Tip: Lock tools are reusable. You don't need to order additional lock tools with every furniture order.

Lock cylinders and the installation tool will be shipped separately so that you can install the locks when you are ready.

To specify lock cylinders, list the total number of lock cylinders that you want with the appropriate style number. If you are specifying key numbers, list the breakdown of the quantity of each key number.

An example of how your order should look is shown below:

Example:

10 LOCK9201FR FR320
5 LOCK9201FR FR350
15 LOCK9201XF XF1100
30 Total

1 877102003SR standard lock tool
1 877102002SR master lock tool

Keying Options

Key random means that the locks will be assigned arbitrarily at the factory with key numbers ranging from FR305 to FR454.

Tip: Random keying can mean that different furniture units will have the same key number. If you must have all locks keyed differently, you should specify key numbers for all locks.

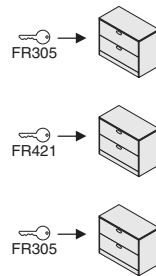

Master key random means that the locks will be assigned arbitrarily at the factory with key numbers ranging from XF1001 to XF1150. All XF locks can be opened with a master key.

Tip: Random keying can mean that different furniture units will have the same key number. If you must have all locks keyed differently, you should specify key numbers for all locks.

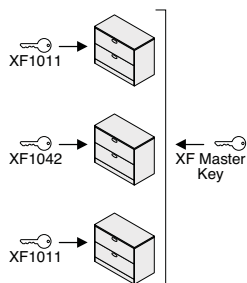

Key specific means that you can specify any key number from FR305 to FR454. This option can be used to key all the furniture units in a workstation or department the same.

Tip: Designate the quantity per key number in your specification when ordering more than one product with the same style number.

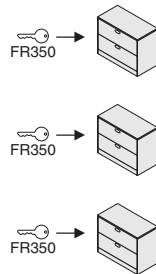

Master key specific means that you can specify any key number from XF1001 to XF1150. All the locks in the XF series can be opened with a master key.

Tip: Designate the quantity per key number in your specification when ordering more than one product with the same style number.

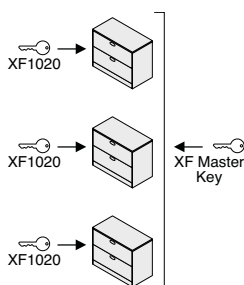

Key consecutive means that you can specify lock numbers in a consecutive order to ensure that no two locks have the same key number until the key sequence repeats. You must select a beginning key number from FR305 to FR454.

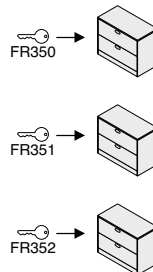

Master key consecutive means that you can specify lock numbers in a consecutive order to ensure that no two locks have the same key number until the key sequence repeats. You must select a beginning key number from XF1001 to XF1150. All the locks in the XF series can be opened with a master key.

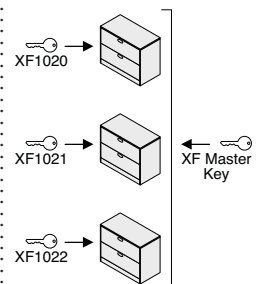

Lock Cylinders

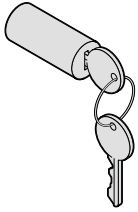

Tip: Lock price is included in price of furniture with locks.

Tip: For replacement lock cylinders, refer to Service Parts.

Tip: You can change lock cylinders in the field by using the appropriate lock tool.

Standard Includes	Required to Specify
-------------------	---------------------

- | | |
|--|--|
| <ul style="list-style-type: none"> Lock cylinder, keyed random: 9201 Polished Chrome or 9250 Ember Chrome Two keys | <ul style="list-style-type: none"> 1 Style number 2 Options, if selected (see below) |
|--|--|

Options	U.S. Price	Required to Specify
Key specific	No cost	Select key number from FR305–FR454.
Key consecutive	No cost	Specify <i>key consecutive</i> and must select beginning key number from FR305–FR454.
Master key random	+\$23 each	Specify <i>master key random</i> .
Master key specific	+\$23 each	Specify key number from XF1001–XF1150.
Master key consecutive	+\$23 each	Specify <i>master key consecutive</i> and must select beginning key number from XF1001–XF1150.

Specification Information

Color	Style Number	U.S. Price
-------	--------------	------------

FR Series (Standard Keying System) – Lock Cylinder

Polished Chrome	LOCK9201FR	No cost
Ember Chrome	LOCK9250FR	No cost

Standard Lock Tool

	877102003SR	\$23
--	--------------------	------

XF Series (Master Keying System) – Lock Cylinder

Polished Chrome	LOCK9201XF	No additional cost. Price included in price of furniture with master-keyed locks.
Ember Chrome	LOCK9250XF	No additional cost. Price included in price of furniture with master-keyed locks.

Master Lock Tool

	877102002SR	\$23
--	--------------------	------

 **For Canadian Pricing**
 Multiply U.S. Price by the Canadian price factor.
 ▶ See page 1 for details.

Style Number Index

Style Number	Page	Description
877102002SR	265	Master Lock Tool
877102003SR	265	Standard Lock Tool
A5LQ58235823U	240	Details Hgt-Adj Table Wksf
A5RQ582323U	240	Details Hgt-Adj Table Wksf
CDFIS14	220	Details In-Line Document Support
CF800	216	Details Flat Panel Monitor Arm
CFDHA	217	Details Flat Panel Monitor Pole Mount
CFSHA	217	Details Flat Panel Monitor Pole Mount
CFSPC	218	Details Flat Panel Monitor Bracket
CFSPTM	218	Details Flat Panel Monitor Bracket
CFTR	219	Details Adjustable Foot Rest
CPRCCN	219	Details Computer Support Tool
CPRSL	219	Details Vert Processor Sling
DDS245	228	Display Shelf
DDS248	228	Display Shelf
DSCW20	227	Cableway
DSCW30	227	Cableway
DSDFB	230	Diagonal File Box
DSLEDF	229	LED Task Light
DSLEDR	229	LED Task Light
DSLLB	231	Landscape Letter Box
DSPB	231	Personal Box
DSR28	226	Rail
DSR34	226	Rail
DSR40	226	Rail
DSR46	226	Rail
DSR52	226	Rail
DSR58	226	Rail
DSR64	226	Rail
DSRT52	84, 105, 226	Tour Rail
DSRT58	84, 105, 226	Tour Rail
DSRT64	84, 105, 226	Tour Rail
DSS2410	228	Shelf
DSS246	228	Shelf
DSS363	228	Shelf
DSSB	232	Storage Box Shelf Set of 3
DSSPB	230	Pile Box
DSTB	230	Tool Box
DSUB	231	Utility Box
FPASINGLECC	216	Details FYI Flat Panel Monitor Arm
L52319MRGG	212	Details Keyboard Platform
L523EN10GG	213	Details Diagonus Keyboard Platform
L72619MRGG	212	Details Keyboard Platform
L726EN10GG	213	Details Diagonus Keyboard Platform
LMINILED	104, 229	Mini LED Task Light
LOCK9201FR	265	Lock Cylinder
LOCK9201XF	265	Lock Cylinder
LOCK9250FR	265	Lock Cylinder
LOCK9250XF	265	Lock Cylinder
LPTL30	124	LED Personal Task Light
LPTL30NR	124	LED Personal Task Light
LT2	104	Underline Light
LT2CHI	104	Underline Light
LUNDERF	239	Details Underline Task Light

Style Number	Page	Description
QACPUT	220	Details I/Q CPU Trolley
SE23JP10SF	215	Details Jules Keyboard Platform
SE23SL10SA	214	Keyboard Support
SS20JP10SF	215	Keyboard Support
SS20SL10SA	214	Keyboard Support
TS2ACMH2	38	Bivi Hook
TS2ACMH4	38	Bivi Hook
TS2ACMS	37	Bivi Top Shelf
TS2ACTH	38	Bivi Bottom Shelf
TS2LD3060PS	29	Turnstone Table
TS2LD3060TS	29	Turnstone Table
TS2P260	32	Bivi Hardwired Powerway
TS2P2CHI	32	Bivi Hardwired Powerway
TS2PBT2	31	Bivi Accessory Base Power-In
TS2PBT2SF	31	Bivi Accessory Base Power-In
TS2PS1PK	30	Bivi Plug and Play Power Kit
TS2PS2PK	30	Bivi Plug and Play Power Kit
TS2PS4PK	30	Bivi Plug and Play Power Kit
TS2PT2T	32	Bivi Table-to-Table Power Connector
TS2RPBSL	37	Bivi Leg
TS2RPFWS	36	Bivi Table Top
TS2RPSWS	36	Bivi Table Top with Back Pocket
TS2RPTC	37	Bivi Pocket Cover
TS2RW	36	Bivi Half-Round Table Top
TS2SDAF3060	25	Bivi Table Plus One
TS2SDAS3060	26	Bivi Table Plus One with Back Pocket
TS2SDWF3060	25	Bivi Table for One
TS2SDWS3060	26	Bivi Table for One with Back Pocket
TS2ST1H1460	33	Bivi Depot
TS2ST2H2860	33	Bivi Big Depot
TS2ST2H4260	33	Bivi Bigger Depot
TS2STEH1660	33	Bivi Trunk
TS2TTAF3060	27	Bivi Table Plus Two
TS2TTAS3060	28	Bivi Table Plus Two with Back Pockets
TS2TTWF3060	27	Bivi Table for Two
TS2TTWS3060	28	Bivi Table for Two with Back Pockets
TS30701	160	Scoop Stool
TS30702	160	Scoop Stool
TS30703	161	Scoop Side Chair
TS30704	161	Scoop Side Chair
TS311EXP	155	Uno Select Mid-Back Multi-Purpose Chair
TS31401	167	Jenny Chair
TS31401C	167	Jenny Chair
TS31401CH	167	Jenny Chair
TS31401CT	167	Jenny Chair
TS31401H	167	Jenny Chair
TS31401T	167	Jenny Chair
TS31402	169	Jenny Chair
TS31402C	169	Jenny Chair
TS31403	172	Jenny Chair
TS31403C	172	Jenny Chair
TS31403CH	172	Jenny Chair
TS31403CT	172	Jenny Chair
TS31403H	172	Jenny Chair

Style Number	Page	Description	Style Number	Page	Description
TS31403T	172	Jenny Chair	TS4TPWRD	132	Campfire Receptacle
TS31404	172	Jenny Chair	TS4TPWRD1	132	Campfire Receptacle
TS31404C	172	Jenny Chair	TS4TRAIL	120	Campfire Center Rail
TS31404CH	172	Jenny Chair	TS4TSCRNL	127	Campfire Screen
TS31404CT	172	Jenny Chair	TS4TSCRNR	127	Campfire Screen
TS31404H	172	Jenny Chair	TS4TSLH	121	Campfire Storage Cabinet
TS31404T	172	Jenny Chair	TS4TSRH	121	Campfire Storage Cabinet
TS31405	183	Jenny Ottoman	TS4TSQLH	121	Campfire Storage Cabinet Wardrobe
TS31405C	183	Jenny Ottoman	TS4TSWRH	121	Campfire Storage Cabinet Wardrobe
TS31406	175	Jenny Chair	TS4TVWM28	132	Campfire Cord Cover
TS31406C	175	Jenny Chair	TS4TVWM40	132	Campfire Cord Cover
TS31407	177	Jenny Chair	TS4TWP	123	Campfire Personal Table
TS31407C	177	Jenny Chair	TS5GF3	92	Flip Grommet
TS31408	181	Jenny Chair	TS5LEGCLP	204	UN FS Wire Clips
TS31409	179	Jenny Chair	TS5SKEXT	204	UN FS Skel Wire Mgr
TS31410	183, 192	alight Ganging Kit	TS5SKLBNE	204	UN FS Skel Wire Mgr
TS31415H	184, 206	Jenny Occasional Table	TS5YMB212	203	Screen Bracket
TS31415L	184, 206	Jenny Occasional Table	TS5YMB218	203	Screen Bracket
TS31416H	184, 206	Jenny Occasional Table	TS5YMB312	203	Screen Bracket
TS31416L	184, 206	Jenny Occasional Table	TS5YMB318	203	Screen Bracket
TS31426	175	Jenny Chair	TS5YMBADP	203	Screen Adapter
TS31426C	175	Jenny Chair	TS5YSL1218	202	Slatwall Screen
TS31428	181	Jenny Chair	TS5YSL1226	202	Slatwall Screen
TS31438	181	Jenny Chair	TS5YSL1230	202	Slatwall Screen
TS31601	188	Lincoln Lounge	TS5YSL1236	202	Slatwall Screen
TS33666	195	Crushed Can Stool	TS5YSL1244	202	Slatwall Screen
TS33667	195	Crushed Can Stool	TS5YSL1260	202	Slatwall Screen
TS33668	195	Crushed Can Stool	TS5YTS1218	202	Desk-mounted Screen
TS34401	191	alight Lounge Ottoman	TS5YTS1227	202	Desk-mounted Screen
TS34402	191	alight Corner Ottoman	TS5YTS1230	202	Desk-mounted Screen
TS34403	191	alight Bench Ottoman	TS5YTS1236	202	Desk-mounted Screen
TS34410T	192, 207	alight End Table	TS5YTS1244	202	Desk-mounted Screen
TS34411T	192, 207	alight Coffee Table	TS5YTS1260	202	Desk-mounted Screen
TS39150	205	Sweeper Martini Table	TS5YTS1818	202	Desk-mounted Screen
TS3BC	129	Campfire Big Lounge	TS5YTS1827	202	Desk-mounted Screen
TS3HL	131	Campfire Half Lounge	TS5YTS1830	202	Desk-mounted Screen
TS3RS	34	Rumble Seat	TS5YTS1836	202	Desk-mounted Screen
TS3RSBKT	34	Rumble Seat	TS5YTS1844	202	Desk-mounted Screen
TS3RSH	35	Hoodie	TS5YTS1860	202	Desk-mounted Screen
TS3WG	131	Campfire Wedge	TSATRC39	92	Reinforcing Channel
TS434EXP	150	cobi Select	TSATRC57	92	Reinforcing Channel
TS466EXP	144	Reply Select	TSATRC72	92	Reinforcing Channel
TS4L27PG	91	Groupwork Post Leg	TSTECB	80	Tour Wksf-Mntd Power and Data
TS4LSHPG	91	Groupwork Post Leg	TSTECBDP	83	Bench Screen
TS4TBL	122	Campfire Big Table	TSTECBT	83	Bench Trough
TS4TL28	118	Campfire Big Table	TSTECC30	81	Vertical Cord Cover
TS4TL40	118	Campfire Big Table	TSTECC42	81	Vertical Cord Cover
TS4TLDRW	120	Campfire Table Drawer	TSTECLAMP	80	Tour Wksf-Mntd Power and Data
TS4TLT28	119	Campfire Big Table with Trough	TSTECM	79	Horizontal Cord Manager
TS4TLT40	119	Campfire Big Table with Trough	TSTEGC	82	Tour Vertical Cord Cover Grommet Insert
TS4TPT	125	Campfire Paper Table	TSTEP172	72	Tour Electrical Component
TS4TPTG	126	Campfire Glass	TSTEP272	72	Tour Electrical Component
TS4TPTP	125	Campfire Paper	TSTEP2C069	74	Tour Electrical Component
TS4TPWR	132	Campfire Receptacle	TSTEP2C075	74	Tour Electrical Component
TS4TPWR1	132	Campfire Receptacle	TSTEP2C081	74	Tour Electrical Component

Style Number Index, continued

Style Number	Page	Description
TSTEP2C087	74	Tour Electrical Component
TSTEP2C093	74	Tour Electrical Component
TSTEP2C099	74	Tour Electrical Component
TSTEP2C105	74	Tour Electrical Component
TSTEP2C111	74	Tour Electrical Component
TSTEP2C117	74	Tour Electrical Component
TSTEP2C120	74	Tour Electrical Component
TSTEP2C123	74	Tour Electrical Component
TSTEP2C126	74	Tour Electrical Component
TSTEP2C129	74	Tour Electrical Component
TSTEP2C132	74	Tour Electrical Component
TSTEP2C135	74	Tour Electrical Component
TSTEP2C138	74	Tour Electrical Component
TSTEP2C141	74	Tour Electrical Component
TSTEP2C144	74	Tour Electrical Component
TSTEP2C147	74	Tour Electrical Component
TSTEP2C150	74	Tour Electrical Component
TSTEP2C153	74	Tour Electrical Component
TSTEP2C156	74	Tour Electrical Component
TSTEP2C159	74	Tour Electrical Component
TSTEP2C162	74	Tour Electrical Component
TSTEP2C165	74	Tour Electrical Component
TSTEP2C168	74	Tour Electrical Component
TSTEP2C171	74	Tour Electrical Component
TSTEP2C174	74	Tour Electrical Component
TSTEP2C177	75	Tour Electrical Component
TSTEP2C180	75	Tour Electrical Component
TSTEP2C183	75	Tour Electrical Component
TSTEP2C186	75	Tour Electrical Component
TSTEP2C189	75	Tour Electrical Component
TSTEP2C192	75	Tour Electrical Component
TSTEP2C195	75	Tour Electrical Component
TSTEP2C198	75	Tour Electrical Component
TSTEP2C201	75	Tour Electrical Component
TSTEP2C204	75	Tour Electrical Component
TSTEP2C207	75	Tour Electrical Component
TSTEP2C210	75	Tour Electrical Component
TSTEP2C213	75	Tour Electrical Component
TSTEP2C216	75	Tour Electrical Component
TSTEP2C219	75	Tour Electrical Component
TSTEP2C222	75	Tour Electrical Component
TSTEP2C225	75	Tour Electrical Component
TSTEP2C228	75	Tour Electrical Component
TSTEP472	72	Tour Electrical Component
TSTEP4C096	76	Tour Electrical Component
TSTEP4C102	76	Tour Electrical Component
TSTEP4C108	76	Tour Electrical Component
TSTEP4C114	76	Tour Electrical Component
TSTEP4C120	76	Tour Electrical Component
TSTEP4C126	76	Tour Electrical Component
TSTEP4C132	76	Tour Electrical Component
TSTEP4C138	76	Tour Electrical Component
TSTEP4C144	76	Tour Electrical Component
TSTEP4C147	76	Tour Electrical Component
TSTEP4C150	76	Tour Electrical Component

Style Number	Page	Description
TSTEP4C153	76	Tour Electrical Component
TSTEP4C156	76	Tour Electrical Component
TSTEP4C159	76	Tour Electrical Component
TSTEP4C162	76	Tour Electrical Component
TSTEP4C165	76	Tour Electrical Component
TSTEP4C168	76	Tour Electrical Component
TSTEP4C171	76	Tour Electrical Component
TSTEP4C174	76	Tour Electrical Component
TSTEP4C177	76	Tour Electrical Component
TSTEP4C180	76	Tour Electrical Component
TSTEP4C183	76	Tour Electrical Component
TSTEP4C186	76	Tour Electrical Component
TSTEP4C189	76	Tour Electrical Component
TSTEP4C192	76	Tour Electrical Component
TSTEP4C195	76	Tour Electrical Component
TSTEP4C198	76	Tour Electrical Component
TSTEP4C201	77	Tour Electrical Component
TSTEP4C204	77	Tour Electrical Component
TSTEP4C207	77	Tour Electrical Component
TSTEP4C210	77	Tour Electrical Component
TSTEP4C213	77	Tour Electrical Component
TSTEP4C216	77	Tour Electrical Component
TSTEP4C219	77	Tour Electrical Component
TSTEP4C222	77	Tour Electrical Component
TSTEP4C225	77	Tour Electrical Component
TSTEP4C228	77	Tour Electrical Component
TSTEP4C231	77	Tour Electrical Component
TSTEP4C234	77	Tour Electrical Component
TSTEP4C237	77	Tour Electrical Component
TSTEP4C240	77	Tour Electrical Component
TSTEP4C243	77	Tour Electrical Component
TSTEP4C246	77	Tour Electrical Component
TSTEP4C249	77	Tour Electrical Component
TSTEP4C252	77	Tour Electrical Component
TSTEP4C255	77	Tour Electrical Component
TSTEPBR130	70	Tour Electrical Component
TSTEPBR142	70	Tour Electrical Component
TSTEPBT2	70	Tour Electrical Component
TSTEPBT230SF	70	Base Power-In
TSTEPBT242SF	70	Base Power-In
TSTEPBT4	71	Tour Electrical Component
TSTEPBT430SF	71	Base Power-In
TSTEPBT442SF	71	Base Power-In
TSTEP2C	73	Tour Electrical Component
TSTEP2C4	73	Tour Electrical Component
TSTERDW	78	Tour Communication Module Pkg
TSTERPDWD	79	Tour Wksf-Mntd Power and Comm Sph
TSTERPDWR	81	Tour Wksf-Mntd Retractable Pwr and Data
TSTERPW	78	Tour Receptacle Pkg
TSTLAPAD	101	Lateral File Cushion
TSTM3072	68	Counter
TSTM4272	68	Counter
TSTMCT1818	69	Countertop
TSTMCT1836	69	Countertop
TSTMCT1854	69	Countertop

Style Number	Page	Description	Style Number	Page	Description
TSTMCT1872	69	Countertop	TSTT27M4	91	Post Leg
TSTMCTN1818	69	Countertop	TSTTF1518	90	Worksurface Support
TSTMCTN1836	69	Countertop	TSTTF2724	90	Worksurface Support
TSTMCTN1854	69	Countertop	TSTTF2730	90	Worksurface Support
TSTMCTN1872	69	Countertop	TSTTL2724	90	Worksurface Support
TSTMHF0970	93	Tour Shelf	TSTTL2730	90	Worksurface Support
TSTMHF2170	93	Tour Shelf	TSTTPC2W	92	Worksurface Support
TSTMHF3370	93	Tour Shelf	TSTTPF2W	92	Worksurface Support
TSTMHF4570L	93	Tour Shelf	TSTTPS2W	92	Worksurface Support
TSTMHF4570R	93	Tour Shelf	TSTTT27	91	Worksurface Support
TSTMLF0970	93	Tour Shelf	TSTTT39	91	Worksurface Support
TSTMLF2170	93	Tour Shelf	TSTTTZD	92	Worksurface Support
TSTMLF3370	93	Tour Shelf	TSTWHDR30	88	Tour Worksurface
TSTMLF4570L	93	Tour Shelf	TSTWHDR36	88	Tour Worksurface
TSTMLF4570R	93	Tour Shelf	TSTWHR1842	85	Tour Worksurface
TSTPB120	96	Screen Connector	TSTWHR1848	85	Tour Worksurface
TSTPB120Y	96	Screen Connector	TSTWHR1854	85	Tour Worksurface
TSTPBCOH2	96	Screen Connector	TSTWHR2436	85	Tour Worksurface
TSTPBCOH3	96	Screen Connector	TSTWHR2442	85	Tour Worksurface
TSTPBSH2	96	Screen Connector	TSTWHR2448	85	Tour Worksurface
TSTPBSH3	96	Screen Connector	TSTWHR2454	85	Tour Worksurface
TSTPBWT	96	Screen Connector	TSTWHR2460	85	Tour Worksurface
TSTPL3024	95	Screen	TSTWHR2466	85	Tour Worksurface
TSTPL3030	95	Screen	TSTWHR2472	85	Tour Worksurface
TSTPL3036	95	Screen	TSTWHR3060	85	Tour Worksurface
TSTPL3042	95	Screen	TSTWHR3066	85	Tour Worksurface
TSTPL3048	95	Screen	TSTWHR3072	85	Tour Worksurface
TSTPL4224	95	Screen	TSTWHT2348	86	Tour Worksurface
TSTPL4230	95	Screen	TSTWHT2354	86	Tour Worksurface
TSTPL4236	95	Screen	TSTWHT2360	86	Tour Worksurface
TSTPL4242	95	Screen	TSTWHT2366	86	Tour Worksurface
TSTPL4248	95	Screen	TSTWHT2372	86	Tour Worksurface
TSTPL4824	95	Screen	TSTWHT3248	86	Tour Worksurface
TSTPL4830	95	Screen	TSTWHT3254	86	Tour Worksurface
TSTPL4836	95	Screen	TSTWHT3260	86	Tour Worksurface
TSTPL4842	95	Screen	TSTWHT3266	86	Tour Worksurface
TSTPL4848	95	Screen	TSTWHT3272	86	Tour Worksurface
TSTPL6024	95	Screen	TSTWHY2436	87	Tour 120° Corner Worksurface
TSTPL6030	95	Screen	TSTWHY2442	87	Tour 120° Corner Worksurface
TSTPL6036	95	Screen	TSTWHY2448	87	Tour 120° Corner Worksurface
TSTPL6042	95	Screen	TSTWLDR30	88	Tour Worksurface
TSTPL6048	95	Screen	TSTWLDR36	88	Tour Worksurface
TSTSBP1818	99	Bookcase	TSTWLR1842	85	Tour Worksurface
TSTSBS3618	99	Bookcase	TSTWLR1848	85	Tour Worksurface
TSTSCHV36	97	HV Cabinet	TSTWLR1854	85	Tour Worksurface
TSTSCHVD36	98	Shared Environmental HV Cabinet	TSTWLR2436	85	Tour Worksurface
TSTSFL1518	100	My File	TSTWLR2442	85	Tour Worksurface
TSTSFL1536	100	My File	TSTWLR2448	85	Tour Worksurface
TSTSP4236	102	Pile File	TSTWLR2454	85	Tour Worksurface
TSTSMB1818	103	Magnetic Markerboard	TSTWLR2460	85	Tour Worksurface
TSTSMB3618	103	Magnetic Markerboard	TSTWLR2466	85	Tour Worksurface
TSTSMT0322	103	Magnetic Tackboard	TSTWLR2472	85	Tour Worksurface
TSTSMT1818	103	Magnetic Tackboard	TSTWLR3060	85	Tour Worksurface
TSTSMT3618	103	Magnetic Tackboard	TSTWLR3066	85	Tour Worksurface
TSTT27M	91	Post Leg	TSTWLR3072	85	Tour Worksurface

Style Number Index, continued

Style Number	Page	Description
TSTWLT2348	86	Tour Worksurface
TSTWLT2354	86	Tour Worksurface
TSTWLT2360	86	Tour Worksurface
TSTWLT2366	86	Tour Worksurface
TSTWLT2372	86	Tour Worksurface
TSTWLT3248	86	Tour Worksurface
TSTWLT3254	86	Tour Worksurface
TSTWLT3260	86	Tour Worksurface
TSTWLT3266	86	Tour Worksurface
TSTWLT3272	86	Tour Worksurface
TSTWLY2436	87	Tour 120° Corner Worksurface
TSTWLY2442	87	Tour 120° Corner Worksurface
TSTWLY2448	87	Tour 120° Corner Worksurface
TSTWMP1242	94	Modesty Panel
TSTWMP1248	94	Modesty Panel
TSTWMP1254	94	Modesty Panel
TSTWMP1260	94	Modesty Panel
TSTWMP1266	94	Modesty Panel
TSTWMP1272	94	Modesty Panel
WBHS	233	Details Binder Holder
WFCS	225	Details Slatwall Stanchion
WFILE	238	Details File Container
WHB	233	Details Hanging Bracket
WHOOK	237	Details Utility Hook
WLTS	234	Details Letter Tray
WMEDIA	234	Details Media Holder
WPCS	236	Details Pen/Pencil Cup
WPROJ	238	Details Project Container
WS24	223	Details Slatwall Tile
WS30	223	Details Slatwall Tile
WS36	223	Details Slatwall Tile, 36"
WS42	223	Details Slatwall Tile, 42"
WS45	223	Details Slatwall Tile, 45"
WS48	223	Details Slatwall Tile, 48"
WS60	223	Details Slatwall Tile, 60"
WSPS	235	Details Personal Shelf
WSQS	236	Details Double Square Dish
WSR24	221	Details SlatRail, 21"
WSR30	221	Details SlatRail, 30"
WSR36	221	Details SlatRail, 36"
WSR42	221	Details SlatRail, 42"
WSR48	221	Details SlatRail, 48"
WSR60	221	Details SlatRail, 60"
WSRFS	222	Details SlatRail Stanchion
WSRU1	221	Details SlatRail Pnl-Mount Brkt
WSRW	222	Details SlatRail Wall-Mount Brkt
WSW42AN	224	Details Slatwall Bracket
WSWANS	224	Details Slatwall Bracket
WSWM	224	Details Slatwall Bracket
WSWUSA	224	Details Slatwall Bracket
WTCS	235	Details Telephone Caddy
WTR0L2	237	Details Simple Trolley

Trademark List

® The following are registered trademarks for products of Steelcase Inc. or one of its related corporate entities: 4 o'clock, 900 Series, à la carte, Airtouch, Ally, Amia, Answer, Archipelago, Avenir, Ballet, Bix, Brayton International, Cachet, Canopy, Canto, Chancellor, Coalesse, Confidante, Context, Convene, CopyCam, Criterion, Crushed Can, Currency, Designtex, Details, Detour, Drive, Elective Elements, Ellipse, Ember Chrome, Emerge, E-Table 2, FYI, Garland, Gentry, Ginkgo Biloba, Groupwork, Ideo, Jacket, Jenny, Jersey, Kart, Kick, LaCosta, Leap, Let's B, LiveBack, Max-Stacker, Metro, Migrations, Mitra, Montage, Nurture, Oriana, Parade, Pathways, PCT, Permiso, Player, PolyVision, Portal, Power Pincher, Progeny, Protégé, R2, Rally, Relevant, Reply, Rizzi Arc, Sensor, Series 9000, Siento, Sieste, Sine, Softcare, Springboard, Steelcase, Steelcase Design Partnership, Stella, Stow Davis, Swathmore, TeamWork, Technique, Texpress, Think, Thunder, Topo, Train, Turnstone, Underline, Unison, Vecta, Viridian, Walden, Werndl, and X-Stack.

® The following are a registered trademarks of AWI Licensing Company, Dover, DE: SoundScapes, DuraBrite, BioBlock, and Armstrong.

® The following registered trademarks are under license from Byrne Electrical, Rockford, MI: Interport and Mini-Port.

® The following is a registered trademark of DuPont, Wilmington, DE: Corian.

® The following is a registered trademark of Genlyte Thomas Company, Louisville, KY: Lightlior.

® The following is a registered trademark of Hilti Corporation, FL-9494 Schaan, Principality of Liechtenstein: Hilti.

® The following is a registered trademark of Leviton Manufacturing Company, Little Neck, NY: Decora.

® The following is a registered trademark of Mechanical Plactics Corp, Elmsford, NY: Toggle.

® The following is a registered trademark of Microsoft Corporation, Redmond, WA: Microsoft.

® The following is a registered trademark of Panduit Corporation, Lockport, IL: Panduit.

® The following is a registered trademark of Trav (Press), Cuneo, Italy: Assisa.

® The following is a registered trademark of Virtual Ink, Boston, MA: mimioActive.

® The following registered trademarks are under license from Wilkhahn Furniture Products: Avera, Senzo, Versal, and Wilkhahn FS.

® The following is a registered trademark of Wilsonart International, Temple, TX: Chemsurf.

® The following is a registered trademark of Wiremold, West Hartford, CT: Wiremold.

® The following is a registered trademark of EMU Group S.P.A., Perugia, Italy: Emu

™ The following are trademarks for products of Steelcase Inc. or one of its related corporate entities: Access, Active/Passive Shelf, Ainsley, Akira, Alcove, Alerion, ailight, Amaris, American Elect, American Tradition, ap40, Arbor, Arriva, Asana, Ascot, Aspekt, Astor, Await, Bira, Bivi, Bottomline, Brook, Burton, c:scape, Calla, Calm, Camber, Campfire, Capa, Cappucino, Cesar, Chester, Chord, Circa, Clarendon, Classic Rectangular, cobi, Collaboration, Community, Company, Convey, Cortex, Coupe, Crea, Crew, Cura, Cypress, Davenport, Dearborn, Deck, Déjà, Denizen, Denska, Derby, Donovan, Dune, Duo, e³, e³ ceramicsteel, e³ environmental ceramicsteel, Echo, Edge, Elсна, Empress, Enea, ēno, EnSync, Enviro, Escapade, Exchange, Exponents, Field, Flat Top, FlexFrame, Flip Top, Flute, Folio, FrameOne, FreeFlow, Frontier, Galilei, Ginger, Ginkgo, Go Wall, Grip, Groove, Hatchback, Hawthorne, Hitch, Host Collection, Huddleboard, i2i, Impact, Indy, InfoLink, IOS, I-Solve, Jack, Jarrah, Jetty, Juice, Kami, Kast, Kathryn, Lark, L'Attitude, LearnLab, Leela, Lincoln, Linden, LiveSeat, Loria, Lyric, Malibu, Malibu Too, Mansfield, Marathon, Martini, Mason, Masque, media:scape, Millbrae, Mineral, Mingle, Mystic, Mystic Metal, Mystic Wood, Montreal, Move, Nadia, Neighbor, nesso, Nickel, Nikko, Nod, node, Norfolk, Ontrak, Oom, Opus, Orchid, Outlook Collection, Ovation, Paloma, Paperflo, Parliament, Pasio, Passerelle, Patriarch, Payback, Peek, Pile File, Pisa, Pool, PUCK, Quba, Rave, Reed, Reunion, Ripple, Riser, Rocco, Rocky, RoomWizard, Runner, Satellite, Sawyer, ScapeSeries, Senti, Sentinel, Senza, Sequoia, Session, ShareLink, Shield, Sidewalk, Skylar, Slumber, Smoke, Snug, Soft Leaf, Sonata, Sorrel, SOTO, Stationkits, Stiletto, Surprise!, Switch, Symphony, Sync, Tava, Tenaro, Terrazzo, Theorem, Topaz, Touchdown, Tour, Tower Too, Trees, Trillium, Trolley, tX2, U-Free, Uno, Verge, Visalia, Waldorf, Woodruff, Workspring, and X-tenz.

™ The following is a trademark of Microsoft Corporation, Redmond, WA: Windows.

™ The following is a trademark of Rodman Industries, Inc., Oconomowoc, WI: ResinCore1.

™ The following is a trademark of Ultrafabrics, LLC, Elmsford, NY: Ultraleather.

™ The following trademarks are used under license from Wilkhahn Furniture: Cana, Linus, Logon, Picto, Range, Stitz, Thema, Timetable, and Tubis.

™ The following is a trademark of MBDC, Charlottesville, VA: Cradle to Cradle.

™ The following trademarks are under license from Walter Knoll: Andoo, Bob, Lazlo, Ribbon, and Together

™ The following trademarks are under license from PP Mobler: Bar and Flag Halyard.

™ The following trademarks are under license from Viccarbe: Davos, Holy Day, Last Minute, RS, and Wrapp.

™ The following trademarks are under license from Carl Hansen: Elbow, Paddle, Shell, Wing, and Wishbone.

™ The following trademarks are under license from Cambridge Sound Management, LLC, Cabridge, MA: Qt PRO Soundmasking, Qt Quiet Technology, and Sonet Qt.

™ The following is a trademark of Electri-Cable Assemblies, Shelton, CT: Interact.

Trademarks used here in are the property of Steelcase, Inc. or of their respective owners.