

Perimeter

PNR

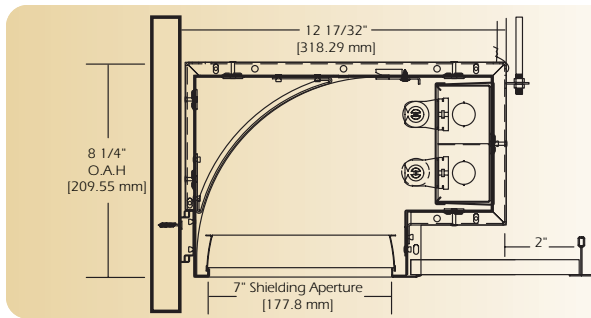

TYPE _____

FEATURES

The PNR perimeter lighting system is designed specially for architectural coves. This flexible lighting system provides ease of installation with adjustable row layouts and patterns. The staggered lamps provide uniform brightness of continuous light. The perimeter system provides design flexibility through reflector and shielding options. The concealed perimeter system is used in architectural settings where the focus is on the lighting, not the fixture.

SPECIFICATIONS

Housing: Fully assembled one-piece die form 20-gauge cold rolled steel. Standard lengths are up to 8 feet. All fixtures are self-flanged. Fixtures join together with alignment brackets and accept 1/4"-20 rods (Supplied by Others). Locking alignment clips join reflectors. Continuous rows consist of standard fixtures and end of row adjustable telescoping fixtures. Telescoping fixtures allow for 12" plus or minus adjustment and extends into corners. The continuous wall rail system provides horizontal adjustment and ease of installation.

Reflector: The reflector is die formed .025 semi-specular anodized aluminum.

Shielding: The semi-specular low iridescent 16 cell parabolic louver is 1 3/8" x 3.0" on center.

Electrical: Ballast is electronic, high power factor, thermally protected class P, sound rated A, with less than 20% total harmonic distortion. The minimum number of ballasts will be used unless otherwise specified.

Mounting: Recessed for grid or flange ceiling.

Finish: Fixture housing and steel components are finished in bake white enamel applied over a five-stage pretreatment process.

Lamps: Fixtures are provided for use with one or two T8 lamp, three and four foot lamps (Supplied by Others).

Certification: Luminaires are U. L. Listed, C. S. A. certified and are Union Made in the United States of America I.B.E.W.

ORDERING GUIDE

MODEL NO.	SHIELDING	NO. OF LAMPS	LAMPS	MOUNTING	ROW LENGTH	VOLTAGE	OPTIONS
PNR	<input type="checkbox"/>	<input type="checkbox"/>	<input type="checkbox"/>	<input type="checkbox"/>	<input type="checkbox"/>	<input type="checkbox"/>	<input type="checkbox"/>
PNR	PBL =Parabolic Louver SCB = Steel Cross Baffle WOA = White Opal Acrylic OPN = Open No Shielding PRS = Prismatic	1 2	T8	G = Grid F = Flange	Total Length of Row	120v 277v	See Options Below

Example: **PNR-PBL-2-T8-G-19'6"-120V**

PNR with parabolic louver and semi-specular reflector for two-32 watt T8 lamps grid ceiling application 19 feet 6 inches 120 volt electronic ballast less than 20% total harmonic distortion.

OPTIONS

- E10=** Electronic ballast, high power factor, thermally protected class P, sound rated A, < 10% total harmonic distortion
- DIM=** Dimming Ballast
- EPC=** Emergency Battery Pack
- EMC=** Emergency Circuit
- QCW=** Quick Connect Wiring
- OTH=** See Accessories for other options available

Perimeter

PNR

FIXTURE DETAILS

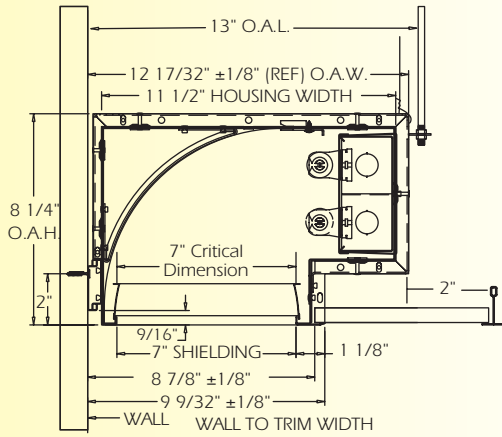

PNR PBL W/ SEMI SPECULAR REFLECTOR

PROFILES

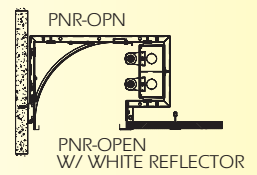
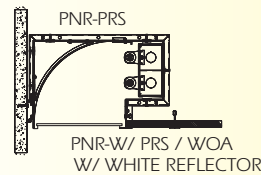
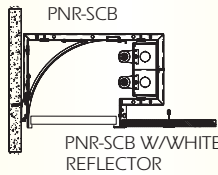

PNR CORNERS

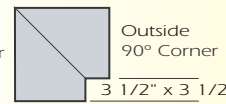
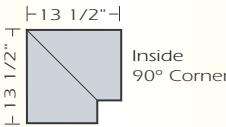

For any angular corner, ()° must be specified and dimensions must be included on the layout
For any pattern, a layout must accompany the order.

PHOTOMETRY

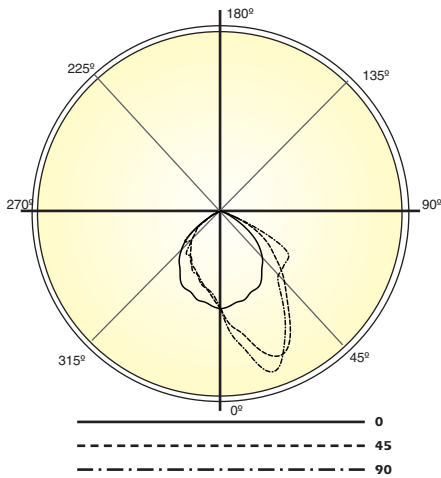

LAMP (1) 32W T8
LUMENS: 2900 PER LAMP

Candela Distribution:

Vert. Angle	0	45	90	135	180
0	658	658	658	658	658
5	648	754	830	774	669
10	627	841	931	832	685
15	613	966	1088	946	634
20	585	1033	1104	1019	609
25	577	1036	998	1025	570
30	535	941	857	920	539
35	484	789	721	787	454
40	440	675	593	681	435
45	380	589	578	578	378
50	313	477	556	463	309
55	217	393	549	383	221
60	129	300	481	313	132
65	60.4	185	247	183	61.1
70	17.3	63.7	59.3	59.0	19.4
75	4.99	10.8	16.6	10.9	4.39
80	3.01	5.56	11.4	6.51	2.95
85	1.26	2.65	2.89	1.85	2.12
90	0.170	0.00	0.00	0.00	0.00

Optical Distribution:
Direct

Coefficients of Utilization - Zonal Cavity Method:

pfc = 0.20

	.8	.7	.5	.3	.1	0												
pcc	.8	.7	.5	.3	.1	0												
pw	.7	.5	.3	.1	.5	.3	.1	.5	.3	.1	0							
RCR	0	67	67	67	65	65	65	65	63	63	63	60	60	60	57	57	57	56
1	62	60	58	57	61	59	57	56	57	55	54	55	53	52	53	52	51	50
2	58	54	51	48	56	53	50	47	51	48	46	49	47	45	47	46	44	43
3	53	48	44	41	52	47	43	40	45	42	40	44	41	39	43	40	38	37
4	49	43	39	35	48	42	38	35	41	37	35	40	37	34	38	36	34	32
5	45	39	34	31	44	38	34	31	37	33	30	36	33	30	35	32	30	29
6	42	35	30	27	41	34	30	27	34	30	27	33	29	26	32	29	26	25
7	39	32	27	24	38	31	27	24	31	27	24	30	26	24	29	26	23	22
8	36	29	25	22	35	29	24	21	28	24	21	27	24	21	27	24	21	20
9	34	27	22	19	33	26	22	19	26	22	19	25	22	19	25	21	19	18
10	32	25	20	18	31	24	20	18	24	20	18	23	20	17	23	20	17	16

Total Luminaire Optical
Efficiency = 56.7%

PHOTOMETRY

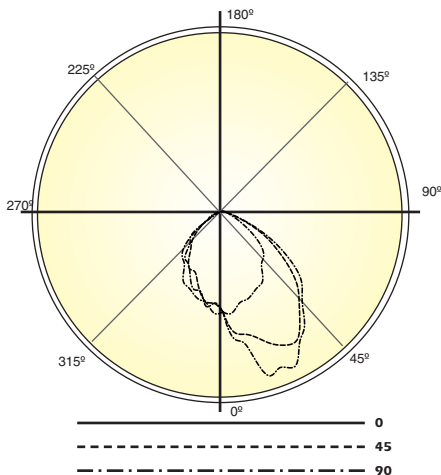

LAMP (2) 32W T8
LUMENS: 2900 PER LAMP

Candela Distribution:

Vert. Angle	0	22.5	45	67.5	90
0	1095	1095	1095	1095	1095
5	1112	1129	1315	1350	1394
10	1017	1270	1359	1515	1484
15	995	1283	1422	1671	1843
20	950	1284	1532	1760	1811
25	906	1306	1607	1705	1862
30	868	1257	1616	1613	1665
35	733	1169	1460	1536	1547
40	679	1129	1292	1279	1350
45	623	1043	1148	1108	1221
50	500	868	939	972	1091
55	335	666	714	738	860
60	193	428	515	515	608
65	96.0	194	282	293	338
70	50.0	83.8	105	95.1	119
75	20.2	27.2	32.9	26.5	47.2
80	17.5	15.0	13.5	18.1	26.6
85	7.58	6.67	4.65	4.51	5.45
90	0.580	0.000	0.270	0.000	0.000

Optical Distribution:
Direct

Coefficients of Utilization - Zonal Cavity Method:

pfc = 0.20

	.8	.7	.5	.3	.1	0												
pcc	.8	.7	.5	.3	.1	0												
pw	.7	.5	.3	.1	.5	.3	.1	.5	.3	.1	0							
RCR	0	59	59	59	57	57	57	57	55	55	55	52	52	52	50	50	50	49
1	55	53	51	49	53	52	50	49	50	48	47	48	47	46	46	45	44	43
2	50	47	44	42	49	46	43	41	44	42	40	43	41	39	41	40	38	37
3	46	42	38	36	45	41	38	35	40	37	35	38	36	34	37	35	33	32
4	43	37	34	31	42	37	33	30	36	32	30	35	32	30	33	31	29	28
5	39	34	30	27	39	33	29	27	32	29	26	31	28	26	30	28	26	25
6	37	30	26	23	36	30	26	23	29	26	23	28	25	23	28	25	23	22
7	34	28	24	21	33	27	23	21	27	23	21	26	23	20	25	22	20	19
8	32	25	21	19	31	25	21	19	24	21	18	24	21	18	23	20	18	17
9	29	23	19	17	29	23	19	17	22	19	17	22	19	17	21	19	16	16
10	28	21	18	15	27	21	18	15	21	17	15	20	17	15	20	17	15	14

Total Luminaire Optical
Efficiency = 49.7%

Perimeter

PNR

ROW LAYOUT

1/LT STAG

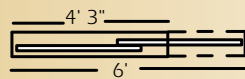
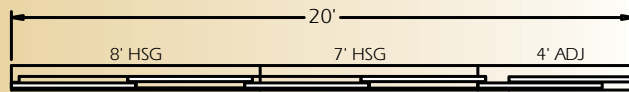
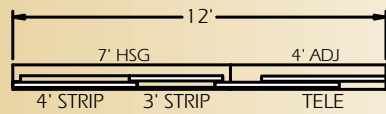

Telescopic Housing and Lamping

2/LT STAG

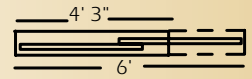
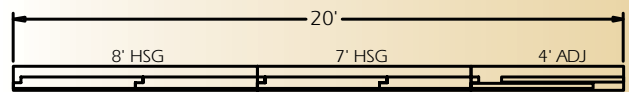
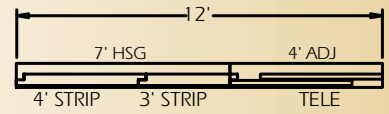

Telescopic Housing and Lamping

PATTERN LAYOUT

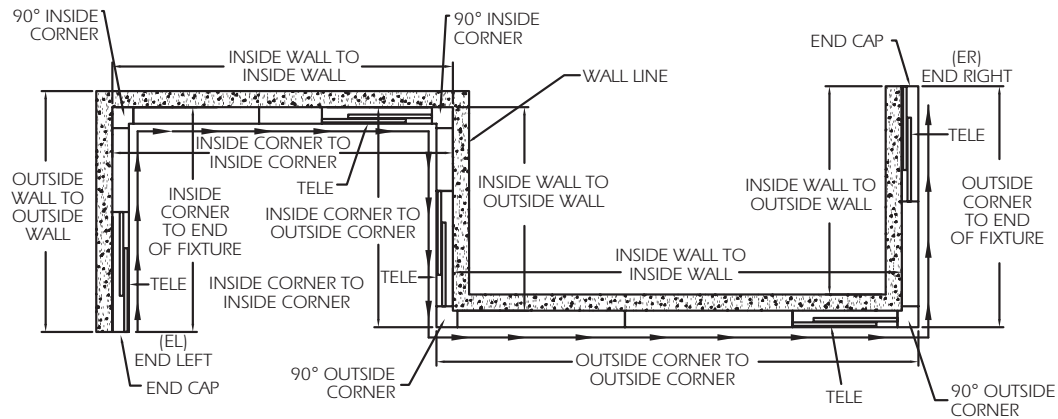

PNR-1 LIGHT LENGTH OF RUN		HOUSINGS AND WALL PLATES							LIGHTING					
MIN	MAX	8'	7'	6'	4'	3'	2'	4' ADJ.	8	6'	4'	3'	2'	4' ADJ. TELE
4'-0"	6'-0"													
6'-0"	7'-0"						1	1						1
7'-0"	8'-0"						1	1						1
8'-0"	9'-0"						1	1					1	1
9'-0"	10'-0"						1	1	1				1	1
10'-0"	11'-0"						1	1	1				1	1
11'-0"	12'-0"						1	1	1	1			1	1
12'-0"	13'-0"		1				1	1	1	1			1	1
13'-0"	14'-0"	1					1	1	1	1			1	1
14'-0"	15'-0"			1			1	1	1	1			1	1
15'-0"	16'-0"			1	1		1	1	1	1			1	1
16'-0"	17'-0"		1		1		1	1	1	1			1	1
17'-0"	18'-0"	1			1		1	1	1	1			1	1
18'-0"	19'-0"		1	1			1	1	1	1			1	1
19'-0"	20'-0"	1		1			1	1	1	1			1	1
20'-0"	21'-0"		1				1	1	1	1			1	1
21'-0"	22'-0"	2					1	2	1	1			1	1
22'-0"	23'-0"	1					1	1	1	1			1	1
23'-0"	24'-0"	1		1	1		1	1	1	1			1	1
24'-0"	25'-0"	2					1	2	1	1			1	1
25'-0"	26'-0"	2			1		1	2	1	1			1	1
26'-0"	27'-0"	1					1	1	1	1			1	1
27'-0"	28'-0"	2	1				1	2	1	1			1	1
28'-0"	29'-0"	2					1	1	1	1			1	1
29'-0"	30'-0"		3				1	1	3	1			1	1
30'-0"	31'-0"	2		1			1	2	1	1			1	1
31'-0"	32'-0"	2	2		1	1	1	1	2	1			1	1
32'-0"	33'-0"	2	1		1		1	3	1	1			1	1
33'-0"	34'-0"	2					1	2	2	1			1	1
34'-0"	35'-0"	2		2			1	2	1	1			1	1
35'-0"	36'-0"	2	2		1		1	3	1	1			1	1
36'-0"	37'-0"	3	1				1	3	1	1			1	1
37'-0"	38'-0"	4					1	4	1	1			1	1
38'-0"	39'-0"	3	1				1	3	1	2			1	1
39'-0"	40'-0"	3		1			1	4	1	1			1	1
40'-0"	41'-0"	4					1	4	1	1			1	1
41'-0"	42'-0"	4	1		1		1	4	1	1			1	1
42'-0"	43'-0"	3					1	3	1	1			1	1
43'-0"	44'-0"	4		1			1	4	1	1			1	1
44'-0"	45'-0"	4	1				1	4	1	1			1	1
45'-0"	46'-0"		5				1	1	5	1			1	1
46'-0"	47'-0"	4		1		1	1	4	1	1			1	1
47'-0"	48'-0"	4			1	1	1	4	1	1			1	1
48'-0"	49'-0"	5					1	5	1	1			1	1
49'-0"	50'-0"	5					1	5	1	1			1	1

PNR-2 LIGHT LENGTH OF RUN		HOUSINGS AND WALL PLATES							LIGHTING					
MIN	MAX	8'	7'	6'	4'	3'	2'	4' ADJ.	8	6'	4'	3'	2'	4' ADJ. TELE
4'-0"	6'-0"													
6'-0"	8'-0"												1	1
7'-0"	9'-0"												1	1
8'-0"	10'-0"										1		1	1
10'-0"	11'-0"										1	1	1	1
11'-0"	12'-0"										1	1	1	1
12'-0"	13'-0"										1	1	1	1
13'-0"	14'-0"	1									1	1	1	1
14'-0"	15'-0"				1						1	1	1	1
15'-0"	16'-0"			1							1	1	1	1
16'-0"	17'-0"		1								1	1	1	1
17'-0"	18'-0"	1									1	1	1	1
18'-0"	19'-0"		1	1							1	1	1	1
19'-0"	20'-0"	1		1							1	1	1	1
20'-0"	21'-0"	1	1								2		1	1
21'-0"	22'-0"	2									1	1	1	1
22'-0"	23'-0"	1									1	1	1	1
23'-0"	24'-0"	1			1						1	1	1	1
24'-0"	25'-0"	2									1	2	1	1
25'-0"	26'-0"	2									1	1	1	1
26'-0"	27'-0"	1	1								2	1	1	1
27'-0"	28'-0"	2									2	1	1	1
28'-0"	29'-0"	2	1								1	3	1	1
29'-0"	30'-0"	3									1	2	1	1
30'-0"	31'-0"	2			1						1	3	1	1
31'-0"	32'-0"	2									1	3	1	1
32'-0"	33'-0"	3									1	3	1	1
33'-0"	34'-0"	2									1	3	1	1
34'-0"	35'-0"	2			1						1	3	1	1
35'-0"	36'-0"	3									1	4	1	1
36'-0"	37'-0"	3	1								1	3	1	1
37'-0"	38'-0"	4									1	3	1	1
38'-0"	39'-0"	3									1	4	1	1
39'-0"	40'-0"	3		1							1	4	1	1
40'-0"	41'-0"	4									1	3	1	1
41'-0"	42'-0"	4									1	4	1	1
42'-0"	43'-0"	3									1	4	1	1
43'-0"	44'-0"	4	1								1	4	1	1
44'-0"	45'-0"	4									1	5	1	1
45'-0"	46'-0"	5									1	5	1	1
46'-0"	47'-0"	4		1							1	5	1	1
47'-0"	48'-0"	4			1	1					1	4	1	1
48'-0"	49'-0"	5									1	5	1	1
49'-0"	50'-0"	5									1	5	1	1

INSTALLATION DETAILS

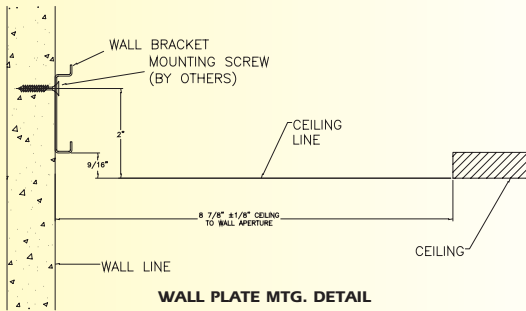

WALL PLATE MTG. DETAIL

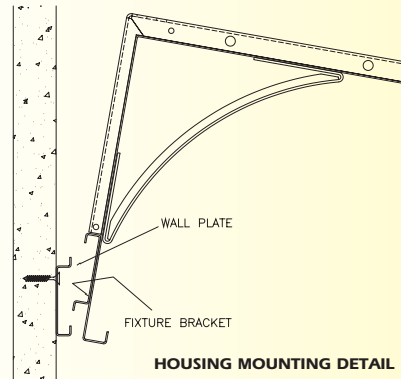

HOUSING MOUNTING DETAIL

INSTALLATION DETAILS

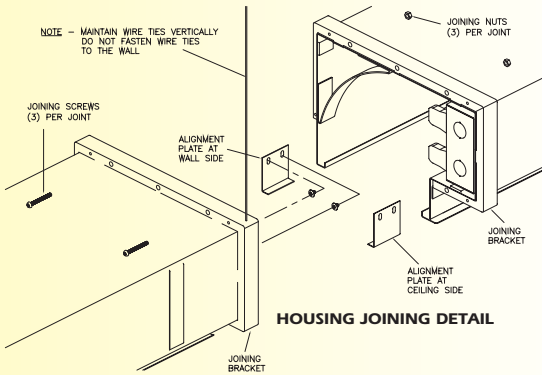

HOUSING JOINING DETAIL

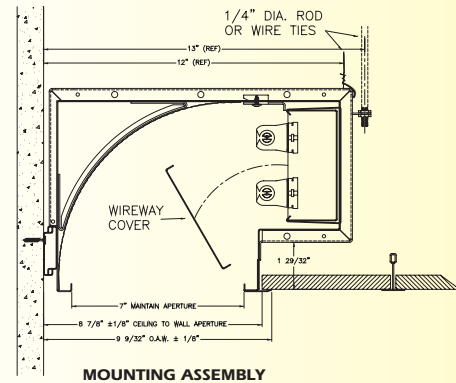

MOUNTING ASSEMBLY

INSTALLATION DETAILS

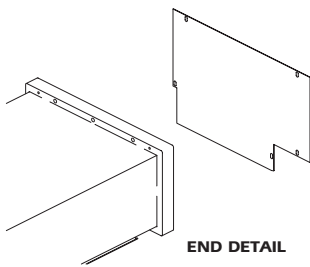

END DETAIL

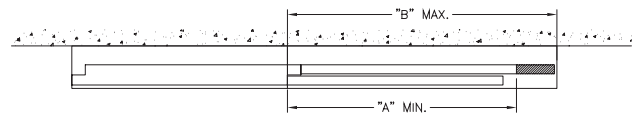

ADJUSTABLE LIGHT STRIP DETAIL

LENGTH	"A"	"B"
4' TELE.	4'-3" MIN.	6'-0" MAX.

