

bridges | connect
share
achieve



LIST PRICE BOOK

Effective March, 2013

A \$25 net handling charge per shipment will be applied for non-UPS-able orders of less than \$2000 list.

BRIDGES II

MODULAR



BRIDGES II

Our desire was to develop an environment for collaborative teamwork which would facilitate connection, or bridging of people and ideas. A set of components which would even serve as a catalyst, inviting team members out of their cocooned comfort zones and encouraging them to engage, co-create. With **Bridges II** you can develop an environment of collaborative teamwork through workspace configuration that enhances line communication and bridges people with a spectrum of ideas and interfaces. Bridges II features a set of components that facilitate communication and streamline interaction through product that efficiently adapts and creatively configures. The product focuses on advancing engagement and collaborative creation through quick adaptations necessary to meet the needs of a fast paced and ever changing work environment. With flexible building components, Bridges II fits numerous applications, from boardrooms to multi-person workstations. It is easy to customize and reconfigure to fit specific requirements.

FEATURES AND BENEFITS:

- High Performance Thermally Fused Laminate Tops are 1" thick
High Pressure Tops are 1 1/16" thick
- Flat matching 3mm edge profile on all sides
- Worksurfaces provided with pilot holes for alignment
- Numerous Power/Data accessories
- Interconnected storage units can form a spine to create space division, storage, cable management and worksurface support
- Leg Options:
Height adjustable Round legs
Fixed height Rectangular legs
- Metal Frame Finishes:
Black (BLK)
Charcoal (CHR)
Designer White (DWT)
Nevada (NEV)
Silver (SIL)
Taupe (TPE)
Tungsten (TUN)
Anodized Aluminum (ANO) - upcharge
- Top Colors:
Avant Honey (AWH)
Avant Cherry (AWC)
Black (BLK)
Brushed Cobalt (BRC)
Constellation Java (CSJ)
Custom Grey (CGY)
Dark Espresso (DES)
Designer White (DWT)
Quartered Mahogany (QTM)
Satin Stainless (SSL)
Storm Grey (SOG)
String (STG)
Taupe (HGT)
Tiger Fruitwood (TFW)
Tiger Mahogany (TMA)
Tiger Maple (TMP)
Tiger Walnut (TWL)
Winter Cherry (WCR)

bridges II connect
share
achieve



Rectangular Leg



Round Leg



Power Trough

TABLE OF CONTENTS

BRIDGES II NOTES.....3-4
BRIDGES II FINISHES5
SAMPLE PACKAGES6-8



RECTANGULAR LEG PACKAGES.....9-13



ROUND LEG PACKAGES.....13-18

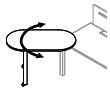

RETURNS18-19

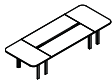

MEETING TABLES.....19-20



LEG ASSEMBLIES21-23



BEAM APPLICATION NOTES24

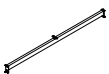

BEAMS25-26

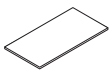

WORKSURFACES27-29

ELECTRICAL SYSTEM NOTES.....30

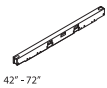

POWER / DATA DELIVERY30-32



ELECTRICAL COMPONENTS32-35



TABLE DIVIDERS35-37



ACCESSORIES38-41



STORAGE.....41-46

INDEX.....47-78

BRIDGES II NOTES

MODULAR

BRIDGES II

FLEXIBLE BUILDING COMPONENTS

- Single leg tables (freestanding or mobile)
- Training Rooms
- Boardrooms
- Libraries
- 1 person general and private office
- 2 person workstation
- 3 person workstation
- 6+ person workstation
- Storage spine-based workstation

EASY TO CUSTOMIZE AND RECONFIGURE to fit specific requirements. From the facility manager's perspective, all workstations can be standardized to form a linear worksurface and power/data services, and their respective function or purpose can be governed by the type, quantity and placement of adjacent components like dividers, storage cabinets, shelves and accessories. These adjacent components can be easily reconfigured with minimal down time - without having to invite electrical and IT crews.

COMPATIBLE WITH VARIOUS ENVIRONMENTS Clean, simple, elegant design language, with finishes suggesting comfortable, even domestic flavor. From understated to designer combinations, like anodized aluminum and white, to give a hint of subtle sophistication.

CHOICE OF TWO FUNCTIONALLY AND VISUALLY DIFFERENT LEG SUPPORTS

- Casters or levelers
- Height adjustable round legs
- Fixed height rectangular legs
- Optional anodized aluminum finish (Rectangular legs only). Refer to individual models for Upcharge.

VARIOUS POWER/DATA DELIVERY LEVELS TO CHOOSE FROM

- Wire basket to organize cable access under worksurfaces and storage units
- Vertical cable manager integrated into rectangular leg
- Worksurface edge-mounted power/data units (easy to reconfigure, plug into wall/floor outlets), or power troughs
- Single-sided and double-sided below worksurface power/data trough (desktop/floor standing computers and office equipment)
- Worksurface access door (access to below worksurface power outlets and data terminals)
- Above worksurface power/data trough provides immediate access for laptops, tablets and phones
- Storage integrated power/data unit
- Horizontal cable management under storage units with optional wire basket

INTERCONNECTED STORAGE UNITS can form a spine to create space division, storage, cable management and worksurface support. Storage leg can be configured to act as a ganging bracket.

WORKSURFACES:

- Standard in high performance thermally fused laminate. Optional high pressure (HP) laminate available.
- High performance thermally fused laminate tops are 1" thick particle board and have a flat matching 3mm edge profile on all sides
- High pressure (HP) laminate tops are 1 1/16" thick laminate particle board and have a flat matching 3mm edge profile on all sides



- Doors and Drawer Fronts feature a matching 3mm edge. All other surfaces feature a matching self edge.

TABLES

- All single pivoting tables are standard with casters
- All multiple linear workstations are standard with levelers
- Tops square for flush surface-to-surface abutment and to accept desk mounted accessories
- Worksurfaces provided with pilot holes for alignment purposes

BRIDGES II NOTES

CODES

This price list uses a numbering system with meaningful alphanumeric characters to create a simple-to-understand product number. This makes specifying the product much easier and more accurate.

Example of a worksurface:

Product code: **BRTWS2472AWC + HP**

BRT = Bridges II

WS = Type of Worksurface

2472 = Size: Depth x Width

AWC = High Pressure Laminate

HP = Finish

HOW TO SPECIFY:

- Specify Bridges II product code in appropriate top material
- Specify top color and edge color- i.e. Laminate color AWC (Avant Cherry)

RECTANGULAR LEG

- For single and shared worksurface support
- Bridges II Rectangular legs are available with: Locking Casters (BRTLCS) or Levelers (BRTLVS)



- Casters and Levelers **CANNOT** be retrofitted
- Levelers have a 2" height range, with 5/16" thread
- Levelers are available in Black only
- Casters are 45mm high with 8mm thread, available in White body/Grey tire combination only
- Leg frame is offered in 7 standard paint finishes and anodized aluminum finish
- Paint finish is a durable, environmentally friendly epoxy powder coating
- When anodized finish is selected, crossbeam is always White

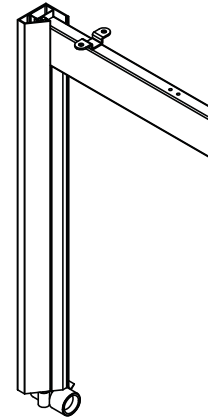

ROUND LEG

- For single and shared worksurface support
- Tubular steel legs are adjustable in 1" increments
- Height adjustment allows the user to easily set the height of a table
- Legs have a height adjustment of 24" - 32" in 1" increments with levelers and 27" - 35" with casters
- Bridges II Round legs are available with: Locking Casters (BRTLCR) or Levelers (BRTLVR)



- Casters and Levelers **CAN** be retrofitted
- Levelers have a 1" height range, with 3/8-16" thread
- Levelers are available in Chrome only
- Casters available in Tungsten/Black combination only
- Casters are 3" diameter with an overall height of 3 3/4" with 3/8-16" thread
- Inner legs are available in Chrome only
- Leg frame is offered in 7 standard paint finishes
- Paint finish is a durable, environmentally friendly epoxy powder coating

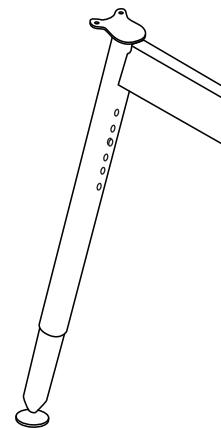

BRIDGES II NOTES

MODULAR

BRIDGES II

METAL FRAME FINISHES:

<u>Finish Color</u>	<u>Finish Code</u>	
Black	BLK	
Charcoal	CHR	
Designer White	DWT	
Nevada	NEV	
Silver	SIL	
Taupe	TPE	
Tungsten	TUN	
Anodized Aluminum	ANO	- Upcharge applies. Refer to individual models for upcharge.

LAMINATE TOP FINISHES:

<u>Finish Color</u>	<u>Finish Code</u>	
Avant Honey	AWH	
Avant Cherry	AWC	
Black	BLK	Coordinates with BLK Metal Frame Finish
Brushed Cobalt	BRC	
Constellation Java	CSJ	
Custom Grey	CGY	Coordinates with SIL Metal Frame Finish
Dark Espresso	DES	
Designer White	DWT	Coordinates with DWT Metal Frame Finish
Quartered Mahogany	QTM	
Satin Stainless	SSL	Coordinates with TUN Metal Frame Finish
Storm Grey	SOG	Coordinates with CHR Metal Frame Finish
String	STG	Coordinates with NEV Metal Frame Finish
Taupe	HGT	Coordinates with TPE Metal Frame Finish
Tiger Fruitwood	TFW	
Tiger Mahogany	TMA	
Tiger Maple	TMP	
Tiger Walnut	TWL	
Winter Cherry	WCR	

CHASSIS/ACCENT FINISHES:

<u>Finish Color</u>	<u>Finish Code</u>	
Avant Honey	AWH	
Avant Cherry	AWC	
Black	BLK	Coordinates with BLK Metal Frame Finish
Custom Grey	CGY	Coordinates with SIL Metal Frame Finish
Designer White	DWT	Coordinates with DWT Metal Frame Finish
River Cherry	RCL	Coordinates with WCR Laminate Finish
Satin Stainless	SSL	Coordinates with TUN Metal Frame Finish
Storm Grey	SOG	Coordinates with CHR Metal Frame Finish
String	STG	Coordinates with NEV Metal Frame Finish
Taupe	HGT	Coordinates with TPE Metal Frame Finish

FABRIC TABLE DIVIDERS:

- Bridges II Fabric Table Dividers are available in:
 Global: **Lola, Brinx, Coordinate, Mariposa and Accent.**
 Momentum: **Meander, Tracery and Universe (extended lead time).**
 The following **Coordinate** and **Accent** codes are available on Bridges II Fabric Table Dividers.

COORDINATE		ACCENT	
CN31 Sand	CN37 Olive	GC31 Sand Dune	GC37 Green Olive
CN32 Stone	CN38 Blue	GC32 Limestone	GC38 Cloud Blue
CN33 Mint	CN39 Cactus	GC33 Silver Mint	GC39 Desert Cactus
CN34 Sky	CN40 Cinder	GC34 Skyway	GC40 Cinder Block
CN35 Beige	CN41 Sage	GC35 Warm Beige	GC41 Sage Brush
CN36 Grey	CN42 Brick	GC36 Mid-Grey	GC42 Brickworks

BRIDGES PACKAGES

Package 1

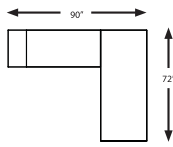
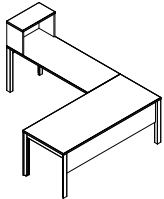

Description	Model Number	Dimensions (inches) d x w x h	Freight Class	Product Wt./Lbs.	Cu. Ft. Per Unit	List Price
Single Person Pod	1 BRTS1P3072L	30 x 72 x 29	70	78	5.01	1203
Single Leg Assembly, Levelers	1 BRTSL24L	24 x 2.5 x 29	150	8	1.34	300
Telescopic Table Beam	1 BRTTB60	1 x 72.5 x 2	60	7.75	.08	338
Rectangular Worksurface	1 BRTWS2460	24 x 60 x 1	60	39	1.30	302
Single Sided Elevated Table Shelf	1 BRTSTS1624	12 x 24 x 16	125	19	2.66	240
Laminate Modesty Panel	1 BRTMPS72	0.75 x 72 x 14	60	19	.43	413

PACKAGE TOTAL

2796

Package 2

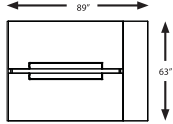
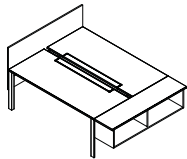

Rectangular Leg Back-to-Back 2 Person Pod, with Levelers, Access doors	1 BRTBAR2PA3072L	62.5 x 72 x 29	70	152	9.54	2205
Perpendicular End-of-Run Laminate Panel	1 BRTLPE63	0.75 x 62.5 x 16	60	19	.43	510
Table Mounted End Shelf	1 BRTTES63	15.5 x 62.5 x 15	100	68	8.40	1103

PACKAGE TOTAL

3818

Package 3

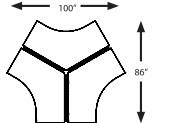
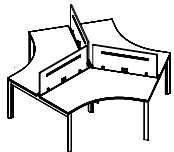

Back-to-Back Leg	3 BRTBA51L	50.5 x 2.5 x 29	150	12	2.96	390 x3
120° Leg	3 BRT120L	34 x 2.5 x 29	250	6.60	2.80	690 x3
Laminate Table Mounted Divider	3 BRTLDD42	0.75 x 39 x 16	60	12	.27	263 x3
120° Worksurface	3 BRTWAC120424224	24 x 42 x 1	65	31	1.06	683 x3

PACKAGE TOTAL

6078

Package 4

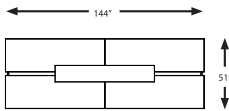
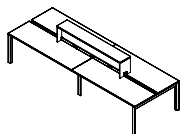

Rectangular Leg, Back-to-Back 4 Person Table	1 BRTBAR4P2472L	50.5 x 144 x 29	70	240	14.74	3354
Above Worksurface Power Trough	1 BRTETA72KIT	2.5 x 71.9 x 3.5	65	8.12	.36	615
Shared Elevated Table Shelf	1 BRTBS1672	12 x 72 x 16	150	44	8	660
Duplex	2 BRT8D1	1.25 x 4.625 x 2	70	.10	.01	30 x2
Isolated Duplex	2 BRT8DA	1.25 x 4.625 x 2	70	.10	.01	30 x2
Base Feed	1 BRT8BF	6 x 72 x 4	250	4	2	417
Electrical Trough End Cap	2 BRTETEC	0.5 x 2.25 x 3.1	70	.10	.01	5 x2

PACKAGE TOTAL

5176

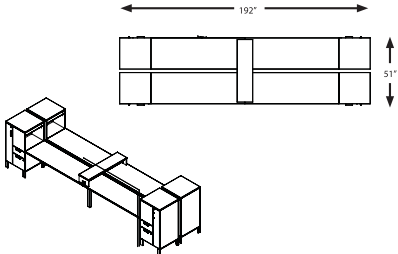
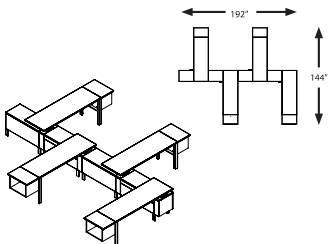
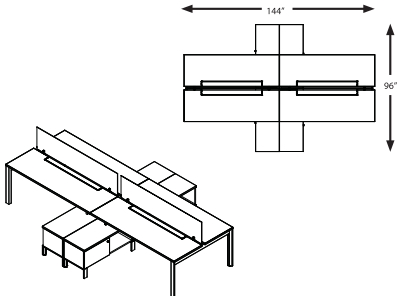
Description	Model Number	Dimensions (inches) d x w x h	Freight Class	Product Wt./Lbs.	Cu. Ft. Per Unit	List Price	
Package 5							
	2	BRTTW5024L	24 x 24 x 50	100	142	16.66	1635 x2
Storage Tower with Coat Storage, Right	2	BRTTW5024R	24 x 24 x 50	100	142	16.66	1635 x2
Shared Elevated Table Shelf	1	BRTBTS0848	12 x 48 x 8	125	21	2.66	360
Rectangular Worksurface	4	BRTWS2472	24 x 72 x 1	60	47	1.54	329 x4
Storage Table Beam	4	BRTSTB72	1 x 68.75 x 2	60	7.35	.08	248 x4
Rectangular Leg	1	BRTBA34L	34 x 2.5 x 29	150	10	2.47	360
PACKAGE TOTAL						9568	
Package 6							
	4	BRT25LBF42L	18 x 42 x 25	100	104	10.93	1275 x4
Vertical Cable Manager	4	BRTVCM2518	18 x 6 x 25	92.5	17	1.56	840 x4
Rectangular Worksurface	4	BRTWS2472	24 x 72 x 1	60	47	1.54	329 x4
Storage Table Beam	4	BRTSTB72	1 x 68.75 x 2	60	7.35	.08	248 x4
Storage Table Beam Adaptor	4	BRTSA25	1 x 15.2 x 2.75	60	4.30	.02	75 x4
Table Mounted End Shelf	4	BRTTES24	15.5 x 24 x 15	100	29	3.22	555 x4
Single Leg Assembly	4	BRTSL24L	24 x 2.5 x 29	150	8	1.34	300 x4
PACKAGE TOTAL						14,488	
Package 7							
	2	BRTBA51L	50.5 x 2.5 x 29	150	12	2.96	390 x2
Storage Table Beam	4	BRTSTB72	1 x 68.75 x 2	60	7.35	.08	248 x4
Storage Table Beam Adaptor	4	BRTSA21	1 x 15.2 x 6.5	60	2.15	.05	90 x4
Worksurface with Access Door	4	BRTWSA2472	24 x 72 x 1	60	47	1.54	398 x4
Glass Table Mounted Divider	2	BRTAGDD72	0.25 x 69 x 16	60	25	.16	540 x2
21\" Sliding Door Storage	4	BRT21LS42L	18 x 42 x 21	125	67	9.18	870 x4
PACKAGE TOTAL						8284	

Package 8

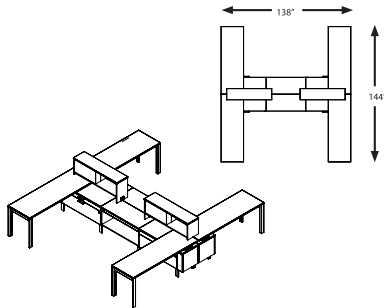

Description	Model Number	Dimensions (inches) d x w x h	Freight Class	Product Wt./Lbs.	Cu. Ft. Per Unit	List Price
Vertical Cable Manager	4 BRTVCM2518	18 x 6 x 25	92.5	17	1.56	840 x4
25" Open Storage	2 BRT25L042L	18 x 42 x 25	150	62	10.93	720 x2
25" Box File Lateral	4 BRT25LBF42L	18 x 42 x 25	100	104	10.93	1275 x4
45" High Shared Divider Storage	2 BRTSDS48	12 x 48 x 16	92.5	54	5.33	480 x2
Storage Table Beam	4 BRTSTB72	1 x 68.75 x 2	60	7.35	.08	248 x4
Storage Table Beam Adaptor	4 BRTSA25	1 x 15.2 x 2.75	60	4.30	.02	75 x4
Single Leg Assembly	4 BRTSL24L	24 x 2.5 x 29	150	8	1.34	300 x4
Worksurface	4 BRTWS2472	24 x 72 x 1	60	47	1.54	329 x4
Flat Bracket	4 BHBF01	4 x 3 x 0.1	70	.50	.01	14 x4
PACKAGE TOTAL						14,724

Package 9

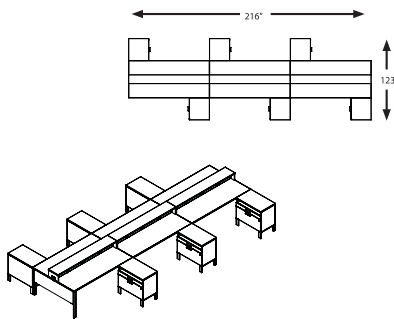

Back-to-Back 6 Person Pod	1 BRTBAR6P2472L	50.5 x 216 x 29	70	359	21.32	4821
Above Desk Worksurface Power	3 BRTTEA72KIT	2.5 x 71.9 x 3.5	65	8.12	.36	615 x3
29" Box File Open Storage	6 BRT29LOBF36L	18 x 36 x 29	92.5	111	10.87	1305 x6
Shared Elevated Table Shelf	3 BRTBTS0872	12 x 72 x 8	125	30	4	480 x3
Duplex	6 BRT8D1	1.25 x 4.625 x 2	70	.10	.01	30 x6
Isolated Duplex	6 BRT8DA	1.25 x 4.625 x 2	70	.10	.01	30 x6
Housing to Housing Harness	2 BRTHH28	0.5 x 28 x 2	70	1	1.17	134 x2
Base Feed	1 BRTBEF	6 x 72 x 4	250	4	2	417
Laminate Gable	2 BRTPEG51	0.75 x 50.5 x 14	60	13	.30	330 x2
Electrical Trough End Cap	2 BRTETEC	0.5 x 2.25 x 3.1	70	.10	.01	5 x2
PACKAGE TOTAL						17,651

Package 10

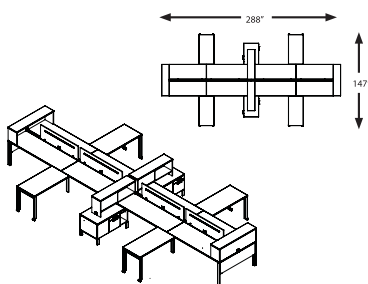

Rectangular Leg Back-to-Back 8 Person Pod	1 BRTBAR8P2472L	50.5 x 288 x 29	70	484	26.30	6288
Rectangular Leg Sliding Table Kit	4 BRTSLDT72C	72 x 48 x 29	92.5	28.50	2.40	600 x4
Laminate Table Divider	2 BRTLDD54	0.75 x 51 x 16	60	15	.35	300 x2
Laminate Table Divider	2 BRTLDD60	0.75 x 57 x 16	60	17	.39	315 x2
25" Shared Storage	2 BRT25LBF042L	24 x 42 x 25	100	154	16.66	1695 x2
45" High Shared Storage Divider	2 BRTSDS48	12 x 48 x 16	92.5	54	5.33	480 x2
Single-Sided Elevated Table Shelf	2 BRTSTS1651	12 x 50.5 x 16	150	33	5.61	420 x2
Rectangular Worksurface	4 BRTWS2448	24 x 48 x 1	65	31	1.06	228 x4
PACKAGE TOTAL						16,020

MODULAR

Description	Model Number	Dimensions (inches) d x w x h	Freight Class	Product Wt./Lbs.	Cu. Ft. Per Unit	List Price	HP Add
RECTANGULAR LEG PACKAGES							
	BRTS1P2484L	24 x 84 x 29	70	75	4.92	1223	117
	BRTS1P2478L	24 x 78 x 29	85	72	4.82	1187	111
	BRTS1P2472L	24 x 72 x 29	85	69	4.73	1146	116
	BRTS1P2466L	24 x 66 x 29	85	66	4.65	1133	102
	BRTS1P2463L	24 x 62.5 x 29	85	63	4.57	1124	100
	BRTS1P2460L	24 x 60 x 29	85	60	4.48	1112	99
	BRTS1P2454L	24 x 54 x 29	85	57	4.40	1073	85
	BRTS1P2451L	24 x 50.5 x 29	85	54	4.30	1044	81
	BRTS1P2448L	24 x 48 x 29	85	51	4.20	1016	76
	BRTS1P2442L	24 x 42 x 29	92.5	48	4.10	971	63
	BRTS1P2436L	24 x 36 x 29	92.5	45	4.0	912	54
	BRTS1P3084L	30 x 84 x 29	70	84	5.20	1283	126
	BRTS1P3078L	30 x 78 x 29	70	81	5.10	1233	116
	BRTS1P3072L	30 x 72 x 29	70	78	5.01	1203	113
	BRTS1P3066L	30 x 66 x 29	70	75	4.90	1175	108
	BRTS1P3063L	30 x 62.5 x 29	70	72	4.80	1166	105
	BRTS1P3060L	30 x 60 x 29	85	69	4.73	1155	102
	BRTS1P3054L	30 x 54 x 29	85	66	4.60	1128	84
	BRTS1P3051L	30 x 50.5 x 29	85	63	4.50	1107	89
	BRTS1P3048L	30 x 48 x 29	85	60	4.41	1088	85
	BRTS1P3042L	30 x 42 x 29	85	57	4.30	1065	83
	BRTS1P3036L	30 x 36 x 29	85	54	4.20	983	58

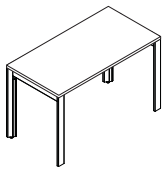

Single Line 1 Person Pod with Levelers

Single Line Table Assemblies consist of one worksurface, two leg assemblies, and one supporting structural beam.

Required Specifications

- Finish (top)
- Metal Finish (legs)

Optional Specifications

- Anodized Aluminum Leg
Add...\$105.00 list upcharge
- High Pressure Laminate

BRIDGES II

	BRTS1P2484C	24 x 84 x 29	70	75	4.92	1283	117
	BRTS1P2478C	24 x 78 x 29	85	72	4.82	1247	111
	BRTS1P2472C	24 x 72 x 29	85	69	4.73	1214	108
	BRTS1P2466C	24 x 66 x 29	85	66	4.65	1193	102
	BRTS1P2463C	24 x 62.5 x 29	85	63	4.57	1184	100
	BRTS1P2460C	24 x 60 x 29	85	60	4.48	1172	99
	BRTS1P2454C	24 x 54 x 29	85	57	4.40	1133	85
	BRTS1P2451C	24 x 50.5 x 29	85	54	4.30	1104	81
	BRTS1P2448C	24 x 48 x 29	85	54	4.20	1076	76
	BRTS1P2442C	24 x 42 x 29	92.5	48	4.10	1031	63
	BRTS1P2436C	24 x 36 x 29	92.5	45	4.0	972	54
	BRTS1P3084C	30 x 84 x 29	70	84	5.20	1353	116
	BRTS1P3078C	30 x 78 x 29	70	81	5.10	1293	116
	BRTS1P3072C	30 x 72 x 29	70	78	5.01	1263	98
	BRTS1P3066C	30 x 66 x 29	70	75	4.90	1235	108
	BRTS1P3063C	30 x 62.5 x 29	70	72	4.90	1226	105
	BRTS1P3060C	30 x 60 x 29	85	69	4.73	1215	102
	BRTS1P3054C	30 x 54 x 29	85	66	4.60	1188	84
	BRTS1P3051C	30 x 50.5 x 29	85	63	4.50	1167	89
	BRTS1P3048C	30 x 48 x 29	85	60	4.41	1148	85
	BRTS1P3042C	30 x 42 x 29	85	57	4.30	1125	83
	BRTS1P3036C	30 x 36 x 29	85	54	4.20	1043	58

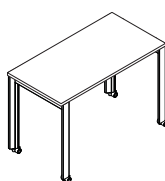

Single Line 1 Person Pod with Casters

Single Line Table Assemblies consist of one worksurface, two leg assemblies, and one supporting structural beam. 40mm white locking casters with grey tires; steel horizontal beams, aluminum legs.

Required Specifications

- Finish (top)
- Metal Finish (legs)

Optional Specifications

- Anodized Aluminum Leg
Add...\$105.00 list upcharge
- High Pressure Laminate

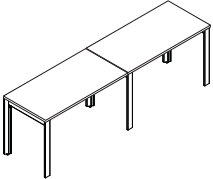
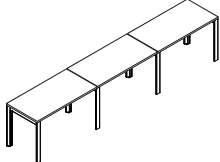
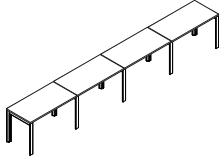
Description	Model Number	Dimensions (inches) d x w x h	Freight Class	Product Wt./Lbs.	Cu. Ft. Per Unit	List Price	HP Add
 <p>Single Line 2 Person Pod with Levelers Single Line 2 Person workstation consists of two worksurfaces, three leg assemblies, and two supporting structural beams. One leg can be shared by 2 adjoining worksurfaces.</p>	BRTS2P2484L	24 x 168 x 29	70	149	7.41	2145	234
	BRTS2P2478L	24 x 156 x 29	70	140	7.27	2073	222
	BRTS2P2472L	24 x 144 x 29	70	131	7.13	2007	216
	BRTS2P2466L	24 x 132 x 29	70	122	6.95	1965	204
	BRTS2P2460L	24 x 120 x 29	70	113	6.71	1923	198
	BRTS2P2454L	24 x 108 x 29	70	104	6.45	1845	171
	BRTS2P2448L	24 x 96 x 29	70	95	6.21	1731	153
	BRTS2P3084L	30 x 168 x 29	70	173	8.25	2250	252
	BRTS2P3078L	30 x 156 x 29	70	164	7.97	2151	231
	BRTS2P3072L	30 x 144 x 29	70	155	7.69	2106	225
	BRTS2P3066L	30 x 132 x 29	70	140	7.41	2034	216
	BRTS2P3060L	30 x 120 x 29	70	131	7.13	1995	204
	BRTS2P3054L	30 x 108 x 29	70	122	6.85	1938	171
	BRTS2P3048L	30 x 96 x 29	70	113	6.57	1860	171
 <p>Single Line 3 Person Pod with Levelers Single Line 3 Person workstation consists of three worksurfaces, four leg assemblies, and three supporting structural beams. One leg can be shared by 2 adjoining worksurfaces.</p>	BRTS3P2484L	24 x 252 x 29	70	219	9.74	3068	351
	BRTS3P2478L	24 x 234 x 29	70	206	9.53	2960	333
	BRTS3P2472L	24 x 216 x 29	70	192	9.32	2861	324
	BRTS3P2466L	24 x 198 x 29	70	179	9.11	2798	306
	BRTS3P2460L	24 x 180 x 29	70	165	8.89	2735	283
	BRTS3P2454L	24 x 162 x 29	70	152	8.68	2618	256
	BRTS3P2448L	24 x 144 x 29	70	138	8.47	2447	229
	BRTS3P3084L	30 x 252 x 29	65	263	11.59	3218	378
	BRTS3P3078L	30 x 234 x 29	70	246	11.16	3069	347
	BRTS3P3072L	30 x 216 x 29	70	229	10.72	2979	338
	BRTS3P3066L	30 x 198 x 29	70	212	10.30	2894	324
	BRTS3P3060L	30 x 180 x 29	70	195	9.87	2835	306
	BRTS3P3054L	30 x 162 x 29	70	178	9.44	2750	256
	BRTS3P3048L	30 x 144 x 29	70	161	9.01	2633	256
 <p>Single Line 4 Person Pod with Levelers Single Line 4 Person workstation consists of four worksurfaces, five leg assemblies, and four supporting structural beams. One leg can be shared by 2 adjoining worksurfaces.</p>	BRTS4P2484L	24 x 336 x 29	70	291	13.67	3990	468
	BRTS4P2478L	24 x 312 x 29	70	273	13.18	3846	444
	BRTS4P2472L	24 x 288 x 29	70	254	12.69	3737	438
	BRTS4P2466L	24 x 264 x 29	70	236	12.20	3630	408
	BRTS4P2460L	24 x 240 x 29	70	217	11.71	3546	396
	BRTS4P2454L	24 x 216 x 29	70	199	11.22	3390	342
	BRTS4P2448L	24 x 192 x 29	70	180	10.73	3162	306
	BRTS4P3084L	30 x 336 x 29	65	345	14.87	4185	504
	BRTS4P3078L	30 x 312 x 29	65	323	14.30	3987	462
	BRTS4P3072L	30 x 288 x 29	70	301	13.73	3867	450
	BRTS4P3066L	30 x 264 x 29	70	279	13.16	3753	432
	BRTS4P3060L	30 x 240 x 29	70	257	12.59	3675	408
	BRTS4P3054L	30 x 216 x 29	70	235	12.02	3561	342
	BRTS4P3048L	30 x 192 x 29	70	213	11.45	3405	342

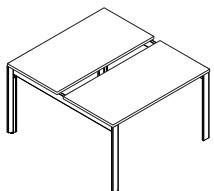
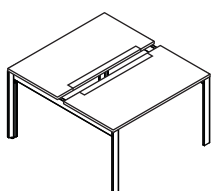
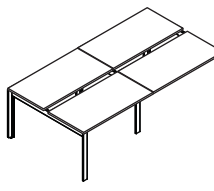
Description	Model Number	Dimensions (inches) d x w x h	Freight Class	Product Wt./Lbs.	Cu. Ft. Per Unit	List Price	HP Add
 <p>Back-to-Back 2 Person Pod with Levelers Back-to-back 2 Person workstation consists of two worksurfaces, two back-to-back leg assemblies, and two supporting structural beams.</p>	BRTBAR2P2484L	50.5 x 84 x 29	70	146	9.40	2025	234
	BRTBAR2P2478L	50.5 x 78 x 29	85	137	9.20	1953	222
	BRTBAR2P2472L	50.5 x 72 x 29	85	128	9.02	1887	216
	BRTBAR2P2466L	50.5 x 66 x 29	85	119	8.76	1845	204
	BRTBAR2P2460L	50.5 x 60 x 29	85	110	8.56	1803	198
	BRTBAR2P3084L	62.5 x 84 x 29	70	174	10.40	2085	252
	BRTBAR2P3078L	62.5 x 78 x 29	70	163	9.80	1994	223
	BRTBAR2P3072L	62.5 x 72 x 29	70	152	9.54	1929	222
	BRTBAR2P3066L	62.5 x 66 x 29	70	141	9.25	1869	216
	BRTBAR2P3060L	62.5 x 60 x 29	85	130	9.00	1830	204
	Required Specifications	Optional Specifications					
	<ul style="list-style-type: none"> ■ Finish (top) ■ Metal Finish (legs) 	<ul style="list-style-type: none"> ○ Anodized Aluminum Leg Add...\$105.00 list upcharge ○ High Pressure Laminate 					
 <p>Back-to-Back 2 Person Pod with Access Door and Levelers Back-to-back 2 Person workstation consists of two worksurfaces, two back-to-back leg assemblies, and two supporting structural beams. Anodized aluminum worksurface door provides access to power/data trough below worksurface. Worksurface with access doors CANNOT be combined with above worksurface power trough.</p>	BRTBAR2PA2484L	50.5 x 84 x 29	70	146	9.40	2130	420
	BRTBAR2PA2478L	50.5 x 78 x 29	85	137	9.20	2070	375
	BRTBAR2PA2472L	50.5 x 72 x 29	85	128	9.02	2025	360
	BRTBAR2PA2466L	50.5 x 66 x 29	85	119	8.76	1950	315
	BRTBAR2PA2460L	50.5 x 60 x 29	85	110	8.56	1875	285
	BRTBAR2PA3084L	62.5 x 84 x 29	70	174	10.40	2325	510
	BRTBAR2PA3078L	62.5 x 78 x 29	70	163	9.80	2250	480
	BRTBAR2PA3072L	62.5 x 72 x 29	70	152	9.54	2205	435
	BRTBAR2PA3066L	62.5 x 66 x 29	70	141	9.25	2130	390
	BRTBAR2PA3060L	62.5 x 60 x 29	85	130	9.00	2025	360
	Required Specifications	Optional Specifications					
	<ul style="list-style-type: none"> ■ Finish (top) ■ Metal Finish (legs) 	<ul style="list-style-type: none"> ○ Anodized Aluminum Leg Add...\$105.00 list upcharge ○ High Pressure Laminate 					
 <p>Back-to-Back 4 Person Pod with Levelers Back-to-back 4 Person workstation consists of four worksurfaces, two back-to-back outer leg assemblies, 1 back-to-back narrow leg assembly, and four supporting structural beams.</p>	BRTBAR4P2484L	50.5 x 168 x 29	70	272	15.66	3630	468
	BRTBAR4P2478L	50.5 x 156 x 29	70	256	15.20	3486	444
	BRTBAR4P2472L	50.5 x 144 x 29	70	240	14.74	3354	432
	BRTBAR4P2466L	50.5 x 132 x 29	70	224	14.28	3270	408
	BRTBAR4P2460L	50.5 x 120 x 29	70	208	13.82	3186	396
	BRTBAR4P3084L	62.5 x 168 x 29	70	333	16.86	3780	504
	BRTBAR4P3078L	62.5 x 156 x 29	70	313	16.32	3582	462
	BRTBAR4P3072L	62.5 x 144 x 29	70	293	15.78	3462	450
	BRTBAR4P3066L	62.5 x 132 x 29	70	273	15.24	3348	432
	BRTBAR4P3060L	62.5 x 120 x 29	70	253	14.70	3270	408
	Required Specifications	Optional Specifications					
	<ul style="list-style-type: none"> ■ Finish (top) ■ Metal Finish (legs) 	<ul style="list-style-type: none"> ○ Anodized Aluminum Leg Add...\$157.00 list upcharge ○ High Pressure Laminate 					

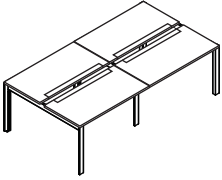
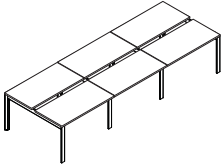
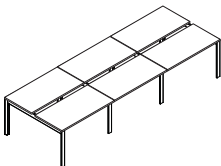
Description	Model Number	Dimensions (inches) d x w x h	Freight Class	Product Wt./Lbs.	Cu. Ft. Per Unit	List Price	HP Add	
 <p>Back-to-Back 4 Person Pod with Access Door and Levelers Back-to-back 4 Person workstation consists of four worksurfaces, two back-to-back outer leg assemblies, 1 back-to-back narrow leg assembly, and four supporting structural beams. Anodized aluminum worksurface door provides access to power/data trough below worksurface. Worksurface with access doors CANNOT be combined with above worksurface power trough.</p>	BRTBAR4PA2484L	50.5 x 168 x 29	70	272	15.66	3840	840	
	BRTBAR4PA2478L	50.5 x 156 x 29	70	256	15.20	3720	750	
	BRTBAR4PA2472L	50.5 x 144 x 29	70	240	14.74	3630	720	
	BRTBAR4PA2466L	50.5 x 132 x 29	70	224	14.28	3480	630	
	BRTBAR4PA2460L	50.5 x 120 x 29	70	208	13.82	3330	570	
	BRTBAR4PA3084L	62.5 x 168 x 29	70	333	16.86	4200	1020	
	BRTBAR4PA3078L	62.5 x 156 x 29	70	313	16.32	4050	960	
	BRTBAR4PA3072L	62.5 x 144 x 29	70	293	15.78	3960	870	
	BRTBAR4PA3066L	62.5 x 132 x 29	70	273	15.24	3810	780	
	BRTBAR4PA3060L	62.5 x 120 x 29	70	253	14.70	3600	720	
	Required Specifications		Optional Specifications					
	■ Finish (top)		● Anodized Aluminum Leg		Add...\$157.00 list upcharge			
	■ Metal Finish (legs)		● High Pressure Laminate					
	 <p>Back-to-Back 6 Person Pod with Levelers Back-to-back 6 Person workstation consists of six worksurfaces, two back-to-back outer leg assemblies, two back-to-back narrow leg assemblies, and six supporting structural beams.</p>	BRTBAR6P2484L	50.5 x 252 x 29	70	434	22.88	5235	702
BRTBAR6P2478L		50.5 x 234 x 29	70	409	22.10	5019	666	
BRTBAR6P2472L		50.5 x 216 x 29	70	359	21.32	4821	648	
BRTBAR6P2466L		50.5 x 198 x 29	70	329	20.54	4695	612	
BRTBAR6P2460L		50.5 x 180 x 29	70	308	19.76	4539	594	
BRTBAR6P3084L		62.5 x 252 x 29	70	493	24.53	5445	756	
BRTBAR6P3078L		62.5 x 234 x 29	70	462	23.75	5148	693	
BRTBAR6P3072L		62.5 x 216 x 29	70	431	22.86	4968	675	
BRTBAR6P3066L		62.5 x 198 x 29	70	400	21.97	4797	648	
BRTBAR6P3060L		62.5 x 180 x 29	70	369	21.08	4650	612	
Required Specifications		Optional Specifications						
■ Finish (top)		● Anodized Aluminum Leg		Add...\$210.00 list upcharge				
■ Metal Finish (legs)		● High Pressure Laminate						
 <p>Back-to-Back 6 Person Pod with Access Door and Levelers Back-to-back 6 Person workstation consists of six worksurfaces, two back-to-back outer leg assemblies, two back-to-back narrow leg assemblies, and six supporting structural beams. Anodized aluminum worksurface door provides access to power/data trough below worksurface. Worksurface with access doors CANNOT be combined with above worksurface power trough.</p>		BRTBAR6PA2484L	50.5 x 252 x 29	70	434	22.88	5550	1260
	BRTBAR6PA2478L	50.5 x 234 x 29	70	409	22.10	5370	1125	
	BRTBAR6PA2472L	50.5 x 216 x 29	70	359	21.32	5235	1080	
	BRTBAR6PA2466L	50.5 x 198 x 29	70	329	20.54	5010	945	
	BRTBAR6PA2460L	50.5 x 180 x 29	70	308	19.76	4755	855	
	BRTBAR6PA3084L	62.5 x 252 x 29	70	493	24.53	6075	1530	
	BRTBAR6PA3078L	62.5 x 234 x 29	70	462	23.75	5850	1440	
	BRTBAR6PA3072L	62.5 x 216 x 29	70	431	22.86	5715	1305	
	BRTBAR6PA3066L	62.5 x 198 x 29	70	400	21.97	5490	1170	
	BRTBAR6PA3060L	62.5 x 180 x 29	70	369	21.08	5145	1080	
	Required Specifications		Optional Specifications					
	■ Finish (top)		● Anodized Aluminum Leg		Add...\$210.00 list upcharge			
	■ Metal Finish (legs)		● High Pressure Laminate					

MODULAR

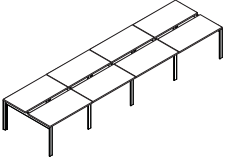
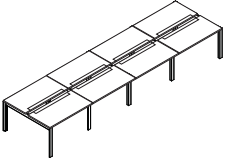
Description	Model Number	Dimensions (inches) d x w x h	Freight Class	Product Wt./Lbs.	Cu. Ft. Per Unit	List Price	HP Add	
 <p>Back-to-Back 8 Person Pod with Levelers Back-to-back 8 Person workstation consists of eight worksurfaces, two back-to-back outer leg assemblies, three back-to-back narrow leg assemblies, and eight supporting structural beams.</p>	BRTBAR8P2484L	50.5 x 336 x 29	70	556	28.30	6840	936	
	BRTBAR8P2478L	50.5 x 312 x 29	70	520	27.30	6552	888	
	BRTBAR8P2472L	50.5 x 288 x 29	70	484	26.30	6288	864	
	BRTBAR8P2466L	50.5 x 264 x 29	70	448	25.30	6120	816	
	BRTBAR8P2460L	50.5 x 240 x 29	70	412	24.42	5982	792	
	BRTBAR8P3084L	62.5 x 336 x 29	70	669	30.58	7110	1008	
	BRTBAR8P3078L	62.5 x 312 x 29	70	625	29.48	6714	924	
	BRTBAR8P3072L	62.5 x 288 x 29	70	581	28.38	6474	900	
	BRTBAR8P3066L	62.5 x 264 x 29	70	536	27.28	6246	864	
	BRTBAR8P3060L	62.5 x 240 x 29	70	492	26.18	6090	816	
		Required Specifications						
		■ Finish (leg)						
		■ Metal Finish (legs)						
		Optional Specifications						
		○ Anodized Aluminum Leg Add....\$264.00 list upcharge						
		○ High Pressure Laminate						
 <p>Back-to-Back 8 Person Pod with Access Door and Levelers Back-to-back 8 Person workstation consists of eight worksurfaces, two back-to-back outer leg assemblies, three back-to-back narrow leg assemblies, and eight supporting structural beams. Anodized aluminum worksurface door provides access to power/data trough below worksurface. Worksurface with access doors CANNOT be combined with above worksurface power trough.</p>	BRTBAR8PA2484L	50.5 x 336 x 29	70	556	28.30	7260	1680	
	BRTBAR8PA2478L	50.5 x 312 x 29	70	520	27.30	7020	1500	
	BRTBAR8PA2472L	50.5 x 288 x 29	70	484	26.30	6840	1440	
	BRTBAR8PA2466L	50.5 x 264 x 29	70	448	25.30	6540	1260	
	BRTBAR8PA2460L	50.5 x 240 x 29	70	412	24.42	6270	1140	
	BRTBAR8PA3084L	62.5 x 336 x 29	70	669	30.58	7950	2040	
	BRTBAR8PA3078L	62.5 x 312 x 29	70	625	29.48	7650	1920	
	BRTBAR8PA3072L	62.5 x 288 x 29	70	581	28.38	7470	1740	
	BRTBAR8PA3066L	62.5 x 264 x 29	70	536	27.28	7170	1560	
	BRTBAR8PA3060L	62.5 x 240 x 29	70	492	26.18	6750	1440	
		Required Specifications						
		■ Finish (top)						
		■ Metal Finish (legs)						
		Optional Specifications						
		○ Anodized Aluminum Leg Add....\$264.00 list upcharge						
		○ High Pressure Laminate						

BRIDGES II

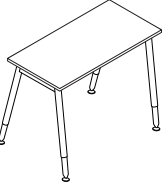
ROUND LEG PACKAGES							
 <p>Round Leg Single Line 1 Person Pod with Levelers Single Line Table Assemblies consist of one worksurface, two leg assemblies, and one supporting structural beam.</p>	BRTS1P2484LR	24 x 84 x 29	70	75	4.92	1259	117
	BRTS1P2478LR	24 x 78 x 29	85	72	4.82	1223	111
	BRTS1P2472LR	24 x 72 x 29	85	69	4.73	1190	108
	BRTS1P2466LR	24 x 66 x 29	85	66	4.65	1169	102
	BRTS1P2463LR	24 x 62.5 x 29	85	63	4.57	1160	100
	BRTS1P2460LR	24 x 60 x 29	85	60	4.48	1148	99
	BRTS1P2454LR	24 x 54 x 29	85	57	4.40	1124	70
	BRTS1P2451LR	24 x 50.5 x 29	85	54	4.30	1080	66
	BRTS1P2448LR	24 x 48 x 29	85	51	4.20	1052	76
	BRTS1P2442LR	24 x 42 x 29	92.5	48	4.10	1007	48
	BRTS1P2436LR	24 x 36 x 29	92.5	45	4.00	974	33
	BRTS1P3084LR	30 x 84 x 29	70	84	5.20	1289	126
	BRTS1P3078LR	30 x 78 x 29	85	81	5.10	1239	116
	BRTS1P3072LR	30 x 72 x 29	85	78	5.01	1209	98
	BRTS1P3066LR	30 x 66 x 29	85	75	4.90	1181	108
	BRTS1P3063LR	30 x 62.5 x 29	85	72	4.80	1172	105
	BRTS1P3060LR	30 x 60 x 29	85	69	4.73	1161	87
	BRTS1P3054LR	30 x 54 x 29	85	66	4.60	1133	85
	BRTS1P3051LR	30 x 50.5 x 29	85	63	4.50	1113	89
	BRTS1P3048LR	30 x 48 x 29	85	60	4.41	1079	85
BRTS1P3042LR	30 x 42 x 29	92.5	57	4.30	1056	83	
BRTS1P3036LR	30 x 36 x 29	92.5	54	4.20	945	59	
	Required Specifications						
	■ Finish (top)						
	■ Metal Finish (legs)						
	Optional Specifications						
	○ High Pressure Laminate						

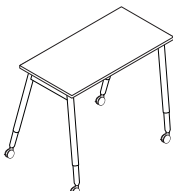
Description	Model Number	Dimensions (inches) d x w x h	Freight Class	Product Wt./Lbs.	Cu. Ft. Per Unit	List Price	HP Add
	BRTS1P2484CR	24 x 84 x 29	70	75	4.92	1331	117
	BRTS1P2478CR	24 x 78 x 29	85	72	4.82	1295	111
	BRTS1P2472CR	24 x 72 x 29	85	69	4.73	1262	108
	BRTS1P2466CR	24 x 66 x 29	85	66	4.65	1241	102
	BRTS1P2463CR	24 x 62.5 x 29	85	63	4.57	1232	100
	BRTS1P2460CR	24 x 60 x 29	85	60	4.48	1220	99
	BRTS1P2454CR	24 x 54 x 29	85	57	4.40	1196	70
	BRTS1P2451CR	24 x 50.5 x 29	85	54	4.30	1152	66
	BRTS1P2448CR	24 x 48 x 29	85	54	4.20	1124	76
	BRTS1P2442CR	24 x 42 x 29	92.5	48	4.10	1079	48
	BRTS1P2436CR	24 x 36 x 29	92.5	45	4.0	1046	33
	BRTS1P3084CR	30 x 84 x 29	70	84	5.20	1361	126
	BRTS1P3078CR	30 x 78 x 29	85	81	5.10	1311	116
	BRTS1P3072CR	30 x 72 x 29	85	78	5.01	1284	95
	BRTS1P3066CR	30 x 66 x 29	85	75	4.90	1253	108
	BRTS1P3063CR	30 x 62.5 x 29	85	72	4.80	1244	105
	BRTS1P3060CR	30 x 60 x 29	85	69	4.73	1233	87
	BRTS1P3054CR	30 x 54 x 29	85	66	4.60	1205	85
	BRTS1P3051CR	30 x 50.5 x 29	85	63	4.50	1185	89
	BRTS1P3048CR	30 x 48 x 29	85	60	4.41	1151	85
BRTS1P3042CR	30 x 42 x 29	92.5	57	4.30	1128	83	
BRTS1P3036CR	30 x 36 x 29	92.5	54	4.20	1017	59	

Round Leg Single Line 1 Person Pod with Casters

Single Line Table Assemblies consist of one worksurface, two leg assemblies, and one supporting structure beam. 40mm white locking casters with grey tires; steel horizontal beams..

Required Specifications

- Finish (top)
- Metal Finish (legs)

Optional Specifications

- High Pressure Laminate

	BRTS2P2484LR	24 x 168 x 29	70	149	7.41	2211	222
	BRTS2P2478LR	24 x 156 x 29	70	140	7.27	2127	222
	BRTS2P2472LR	24 x 144 x 29	70	131	7.13	2061	216
	BRTS2P2466LR	24 x 132 x 29	70	122	6.95	2025	198
	BRTS2P2460LR	24 x 120 x 29	70	113	6.71	1977	198
	BRTS2P2454LR	24 x 108 x 29	70	104	6.45	1899	171
	BRTS2P2448LR	24 x 96 x 29	70	95	6.21	1785	153
	BRTS2P3084LR	30 x 168 x 29	70	173	8.25	2259	252
	BRTS2P3078LR	30 x 156 x 29	70	164	7.97	2160	231
	BRTS2P3072LR	30 x 144 x 29	70	155	7.69	2100	225
	BRTS2P3066LR	30 x 132 x 29	70	140	7.41	2043	216
	BRTS2P3060LR	30 x 120 x 29	70	131	7.13	2004	204
	BRTS2P3054LR	30 x 108 x 29	70	122	6.85	1947	171
	BRTS2P3048LR	30 x 96 x 29	70	113	6.57	1869	171

Round Leg Single Line 2 Person Pod with Levelers

Single Line 2 Person workstation consists of two worksurfaces, three leg assemblies, and two supporting structural beams. One leg can be shared by 2 adjoining worksurfaces.

Required Specifications

- Finish (top)
- Metal Finish (legs)

Optional Specifications

- High Pressure Laminate

MODULAR

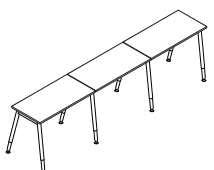
Description	Model Number	Dimensions (inches) d x w x h	Freight Class	Product Wt./Lbs.	Cu. Ft. Per Unit	List Price	HP Add
	BRTS3P2484LR	24 x 252 x 29	70	219	9.74	3140	351
	BRTS3P2478LR	24 x 234 x 29	70	206	9.53	3032	333
	BRTS3P2472LR	24 x 216 x 29	70	192	9.32	2933	324
	BRTS3P2466LR	24 x 198 x 29	70	179	9.11	2870	306
	BRTS3P2460LR	24 x 180 x 29	70	165	8.89	2807	297
	BRTS3P2454LR	24 x 162 x 29	70	152	8.68	2690	256
	BRTS3P2448LR	24 x 144 x 29	70	138	8.47	2519	229
	BRTS3P3084LR	30 x 252 x 29	65	263	11.59	3230	378
	BRTS3P3078LR	30 x 234 x 29	70	246	11.16	3081	347
	BRTS3P3072LR	30 x 216 x 29	70	229	10.72	2991	338
	BRTS3P3066LR	30 x 198 x 29	70	212	10.30	2906	324
	BRTS3P3060LR	30 x 180 x 29	70	195	9.87	2847	306
	BRTS3P3054LR	30 x 162 x 29	70	178	9.44	2762	256
	BRTS3P3048LR	30 x 144 x 29	70	161	9.01	2645	256

Round Leg Single Line 3 Person Pod with Levelers
Single Line 3 Person workstation consists of three worksurfaces, four leg assemblies, and three supporting structural beams. One leg can be shared by 2 adjoining worksurfaces.

- Required Specifications**
- Finish (top)
 - Metal Finish (legs)
- Optional Specifications**
- High Pressure Laminate

BRIDGES II

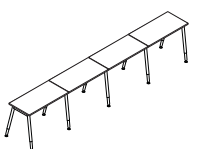
	BRTS4P2484LR	24 x 336 x 29	70	291	13.67	4080	468
	BRTS4P2478LR	24 x 312 x 29	70	273	13.18	3936	444
	BRTS4P2472LR	24 x 288 x 29	70	254	12.69	3804	432
	BRTS4P2466LR	24 x 264 x 29	70	236	12.20	3720	408
	BRTS4P2460LR	24 x 240 x 29	70	217	11.71	3624	408
	BRTS4P2454LR	24 x 216 x 29	70	199	11.22	3480	342
	BRTS4P2448LR	24 x 192 x 29	70	180	10.73	3216	342
	BRTS4P3084LR	30 x 336 x 29	65	345	14.87	4200	504
	BRTS4P3078LR	30 x 312 x 29	65	323	14.30	4002	462
	BRTS4P3072LR	30 x 288 x 29	70	301	13.73	3882	450
	BRTS4P3066LR	30 x 264 x 29	70	279	13.16	3768	432
	BRTS4P3060LR	30 x 240 x 29	70	257	12.59	3690	408
	BRTS4P3054LR	30 x 216 x 29	70	235	12.02	3576	342
	BRTS4P3048LR	30 x 192 x 29	70	213	11.45	3420	342

Round Leg Single Line 4 Person Pod with Levelers
Single Line 4 Person workstation consists of four worksurfaces, five leg assemblies, and four supporting structural beams. One leg can be shared by 2 adjoining worksurfaces.

- Required Specifications**
- Finish (top)
 - Metal Finish (legs)
- Optional Specifications**
- High Pressure Laminate

	BRTBAR2P2484LR	50.5 x 84 x 29	70	146	9.40	2058	234
	BRTBAR2P2478LR	50.5 x 78 x 29	85	137	9.20	2001	222
	BRTBAR2P2472LR	50.5 x 72 x 29	85	128	9.02	1935	216
	BRTBAR2P2466LR	50.5 x 66 x 29	85	119	8.76	1893	204
	BRTBAR2P2460LR	50.5 x 60 x 29	85	110	8.56	1851	198
	BRTBAR2P3084LR	62.5 x 84 x 29	70	174	10.40	2133	252
	BRTBAR2P3078LR	62.5 x 78 x 29	70	163	9.80	2034	231
	BRTBAR2P3072LR	62.5 x 72 x 29	70	152	9.54	1974	216
	BRTBAR2P3066LR	62.5 x 66 x 29	70	141	9.25	1917	216
	BRTBAR2P3060LR	62.5 x 60 x 29	85	130	9.00	1722	360

Round Leg Back-to-Back 2 Person Pod with Levelers
Back-to-back 2 Person workstation consists of two worksurfaces, two back-to-back leg assemblies, and two supporting structural beams.

- Required Specifications**
- Finish (top)
 - Metal Finish (legs)
- Optional Specifications**
- High Pressure Laminate

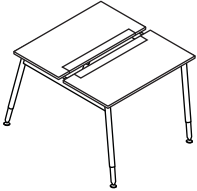
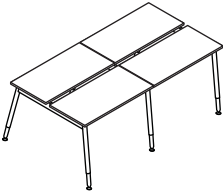
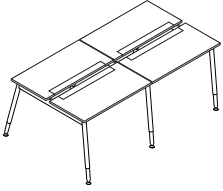
Description	Model Number	Dimensions (inches) d x w x h	Freight Class	Product Wt./Lbs.	Cu. Ft. Per Unit	List Price	HP Add
 <p>Round Leg Back-to-Back 2 Person Pod with Access Door and Levelers Back-to-back 2 Person workstation consists of two worksurfaces, two back-to-back leg assemblies, and two supporting structural beams. Anodized aluminum worksurface door provides access to power/data trough below worksurface. Worksurface with access doors CANNOT be combined with above worksurface power trough.</p>	BRTBAR2PA2484LR	50.5 x 84 x 29	70	146	9.40	2163	420
	BRTBAR2PA2478LR	50.5 x 78 x 29	85	137	9.20	2118	375
	BRTBAR2PA2472LR	50.5 x 72 x 29	85	128	9.02	2073	360
	BRTBAR2PA2466LR	50.5 x 66 x 29	85	119	8.76	1998	315
	BRTBAR2PA2460LR	50.5 x 60 x 29	85	110	8.56	1923	285
	BRTBAR2PA3084LR	62.5 x 84 x 29	70	174	10.40	2343	510
	BRTBAR2PA3078LR	62.5 x 78 x 29	70	163	9.80	2268	480
	BRTBAR2PA3072LR	62.5 x 72 x 29	70	152	9.54	2223	435
	BRTBAR2PA3066LR	62.5 x 66 x 29	70	141	9.25	2148	390
	BRTBAR2PA3060LR	62.5 x 60 x 29	85	130	9.00	2043	360
	Required Specifications	Optional Specifications					
	■ Finish (top)	● High Pressure Laminate					
	■ Metal Finish (legs)						
 <p>Round Leg Back-to-Back 4 Person Pod with Levelers Back-to-back 4 Person workstation consists of four worksurfaces, three back-to-back outer leg assemblies and four supporting structural beams.</p>	BRTBAR4P2484LR	50.5 x 168 x 29	70	272	15.66	3630	468
	BRTBAR4P2478LR	50.5 x 156 x 29	70	256	15.20	3486	444
	BRTBAR4P2472LR	50.5 x 144 x 29	70	240	14.74	3354	432
	BRTBAR4P2466LR	50.5 x 132 x 29	70	224	14.28	3270	408
	BRTBAR4P2460LR	50.5 x 120 x 29	70	208	13.82	3186	396
	BRTBAR4P3084LR	62.5 x 168 x 29	70	333	16.86	3780	504
	BRTBAR4P3078LR	62.5 x 156 x 29	70	313	16.32	3582	462
	BRTBAR4P3072LR	62.5 x 144 x 29	70	293	15.78	3462	450
	BRTBAR4P3066LR	62.5 x 132 x 29	70	273	15.24	3348	432
	BRTBAR4P3060LR	62.5 x 120 x 29	70	253	14.70	3270	408
	Required Specifications	Optional Specifications					
	■ Finish (top)	● High Pressure Laminate					
	■ Metal Finish (legs)						
 <p>Round Leg Back-to-Back 4 Person Pod with Access Door and Levelers Back-to-back 4 Person workstation consists of four worksurfaces, three back-to-back outer leg assemblies and four supporting structural beams. Anodized aluminum worksurface door provides access to power/data trough below worksurface. Worksurface with access doors CANNOT be combined with above worksurface power trough.</p>	BRTBAR4PA2484LR	50.5 x 168 x 29	70	272	15.66	3840	840
	BRTBAR4PA2478LR	50.5 x 156 x 29	70	256	15.20	3720	750
	BRTBAR4PA2472LR	50.5 x 144 x 29	70	240	14.74	3630	720
	BRTBAR4PA2466LR	50.5 x 132 x 29	70	224	14.28	3480	630
	BRTBAR4PA2460LR	50.5 x 120 x 29	70	208	13.82	3330	570
	BRTBAR4PA3084LR	62.5 x 168 x 29	70	333	16.86	4200	1020
	BRTBAR4PA3078LR	62.5 x 156 x 29	70	313	16.32	4050	960
	BRTBAR4PA3072LR	62.5 x 144 x 29	70	293	15.78	3960	870
	BRTBAR4PA3066LR	62.5 x 132 x 29	70	273	15.24	3810	780
	BRTBAR4PA3060LR	62.5 x 120 x 29	70	253	14.70	3600	720
	Required Specifications	Optional Specifications					
	■ Finish (top)	● High Pressure Laminate					
	■ Metal Finish (legs)						

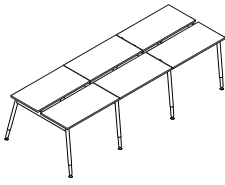
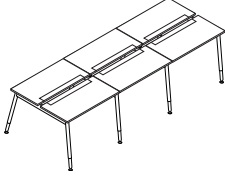
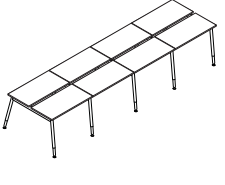
Description	Model Number	Dimensions (inches) d x w x h	Freight Class	Product Wt./Lbs.	Cu. Ft. Per Unit	List Price	HP Add
 <p>Round Leg Back-to-Back 6 Person Pod with Levelers Back-to-back 6 Person workstation consists of six worksurfaces, four back-to-back leg assemblies, and six supporting structural beams.</p>	BRTBAR6P2484LR	50.5 x 252 x 29	70	434	22.88	5235	702
	BRTBAR6P2478LR	50.5 x 234 x 29	70	409	22.10	5019	666
	BRTBAR6P2472LR	50.5 x 216 x 29	70	359	21.32	4821	648
	BRTBAR6P2466LR	50.5 x 198 x 29	70	329	20.54	4695	612
	BRTBAR6P2460LR	50.5 x 180 x 29	70	308	19.76	4539	594
	BRTBAR6P3084LR	62.5 x 252 x 29	70	493	24.53	5445	756
	BRTBAR6P3078LR	62.5 x 234 x 29	70	462	23.75	5148	693
	BRTBAR6P3072LR	62.5 x 216 x 29	70	431	22.86	4968	675
	BRTBAR6P3066LR	62.5 x 198 x 29	70	400	21.97	4797	648
	BRTBAR6P3060LR	62.5 x 180 x 29	70	369	21.08	4650	612
	Required Specifications	Optional Specifications					
	■ Finish (top)	● High Pressure Laminate					
	■ Metal Finish (legs)						
 <p>Round Leg Back-to-Back 6 Person Pod with Access Door and Levelers Back-to-back 6 Person workstation consists of six worksurfaces, four back-to-back leg assemblies, and six supporting structural beams. Anodized aluminum worksurface door provides access to power/data trough below worksurface. Worksurface with access doors CANNOT be combined with above worksurface power trough.</p>	BRTBAR6PA2484LR	50.5 x 252 x 29	70	434	22.88	5550	1260
	BRTBAR6PA2478LR	50.5 x 234 x 29	70	409	22.10	5370	1125
	BRTBAR6PA2472LR	50.5 x 216 x 29	70	359	21.32	5235	1080
	BRTBAR6PA2466LR	50.5 x 198 x 29	70	329	20.54	5010	945
	BRTBAR6PA2460LR	50.5 x 180 x 29	70	308	19.76	4755	855
	BRTBAR6PA3084LR	62.5 x 252 x 29	70	493	24.53	6075	1530
	BRTBAR6PA3078LR	62.5 x 234 x 29	70	462	23.75	5850	1440
	BRTBAR6PA3072LR	62.5 x 216 x 29	70	431	22.86	5715	1305
	BRTBAR6PA3066LR	62.5 x 198 x 29	70	400	21.97	5490	1170
	BRTBAR6PA3060LR	62.5 x 180 x 29	70	369	21.08	5145	1080
	Required Specifications	Optional Specifications					
	■ Finish (top)	● High Pressure Laminate					
	■ Metal Finish (legs)						
 <p>Round Leg Back-to-Back 8 Person Pod with Levelers Back-to-back 8 Person workstation consists of eight worksurfaces, five back-to-back outer leg assemblies, and eight supporting structural beams.</p>	BRTBAR8P2484LR	50.5 x 336 x 29	70	556	28.30	6840	936
	BRTBAR8P2478LR	50.5 x 312 x 29	70	520	27.30	6552	888
	BRTBAR8P2472LR	50.5 x 288 x 29	70	484	26.30	6288	864
	BRTBAR8P2466LR	50.5 x 264 x 29	70	448	25.30	6120	816
	BRTBAR8P2460LR	50.5 x 240 x 29	70	412	24.42	5982	792
	BRTBAR8P3084LR	62.5 x 336 x 29	70	669	30.58	7110	1008
	BRTBAR8P3078LR	62.5 x 312 x 29	70	625	29.48	6714	924
	BRTBAR8P3072LR	62.5 x 288 x 29	70	581	28.38	6474	900
	BRTBAR8P3066LR	62.5 x 264 x 29	70	536	27.28	6246	864
	BRTBAR8P3060LR	62.5 x 240 x 29	70	492	26.18	6090	816
	Required Specifications	Optional Specifications					
	■ Finish (top)	● High Pressure Laminate					
	■ Metal Finish (legs)						

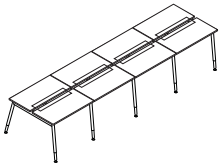

Description	Model Number	Dimensions (inches) d x w x h	Freight Class	Product Wt./Lbs.	Cu. Ft. Per Unit	List Price	HP Add
	BRTBAR8PA2484LR	50.5 x 336 x 29	70	556	28.30	7260	1680
	BRTBAR8PA2478LR	50.5 x 312 x 29	70	520	27.30	7020	1500
	BRTBAR8PA2472LR	50.5 x 288 x 29	70	484	26.30	6840	1440
	BRTBAR8PA2466LR	50.5 x 264 x 29	70	448	25.30	6540	1260
	BRTBAR8PA2460LR	50.5 x 240 x 29	70	412	24.42	6270	1140
	BRTBAR8PA3084LR	62.5 x 336 x 29	70	669	30.58	7950	2040
	BRTBAR8PA3078LR	62.5 x 312 x 29	70	625	29.48	7650	1920
	BRTBAR8PA3072LR	62.5 x 288 x 29	70	581	28.38	7470	1740
	BRTBAR8PA3066LR	62.5 x 264 x 29	70	536	27.28	7170	1560
	BRTBAR8PA3060LR	62.5 x 240 x 29	70	492	26.18	6750	1440

Round Leg Back-to-Back 8 Person Pod with Access Door and Levelers
 Back-to-back 8 Person workstation consists of eight worksurfaces, five back-to-back outer leg assemblies, and eight supporting structural beams. Anodized aluminum worksurface door provides access to power/data trough below worksurface. Worksurface with access doors CANNOT be combined with above worksurface power trough.

- Required Specifications**
- Finish (top)
 - Metal Finish (legs)

- Optional Specifications**
- High Pressure Laminate

RETURNS

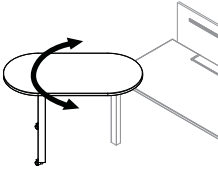
	BRTPR2448C	24 x 48 x 31	70	40	2.04	719	76
	<p>Pivoting Table - Rectangular Legs Racetrack pivoting worksurface with legs and casters. 3mm edging. Pivot clamp attaches anywhere along the edge of the worksurface and is easy to reconfigure. 40mm dia. locking casters with 8mm thread, white body and grey tires. Includes leg, pivot-clamp, 2448 racetrack top and hardware.</p>	<p>Required Specifications</p> <ul style="list-style-type: none"> ■ Finish (top) ■ Metal Finish (legs) 	<p>Optional Specifications</p> <ul style="list-style-type: none"> ○ Anodized Aluminum Leg Add...\$52.00 list upcharge ○ High Pressure Laminate 				

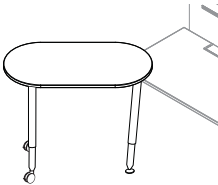
	BRTPO2448CR	24 x 48 x 31	70	40	2.04	719	76
	<p>Pivoting Table - Round Legs Racetrack pivoting worksurface with two legs and casters. 3mm edging. Pivot clamp attaches anywhere along the edge of the worksurface and is easy to reconfigure. 3" dia. locking casters are standard. Optional leveling glides available. Specify 2 BRTLVR. Reduce price by \$XX.00 Includes leg, pivot-clamp, 2448 racetrack top and hardware.</p>	<p>Required Specifications</p> <ul style="list-style-type: none"> ■ Finish (top) ■ Metal Finish (legs) 	<p>Optional Specifications</p> <ul style="list-style-type: none"> ○ High Pressure Laminate 				

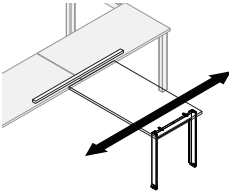
	BRTSLDT72C	72 x 48 x 29	92.5	28.50	2.40	600	N/A
	<p>Rail Sliding Table Kit - Rectangular Legs Includes leg, leg support, sliding bracket hardware, 72" rail and hardware to secure table. Worksurface not included. Legs are for 24" d worksurfaces. 40mm dia. locking casters with 8mm thread, white body and grey tires. Maximum length of sliding table surface is 48".</p>	<p>Required Specifications</p> <ul style="list-style-type: none"> ■ Finish (top) ■ Metal Finish (legs) 	<p>Optional Specifications</p> <ul style="list-style-type: none"> ○ Anodized Aluminum Leg Add...\$52.00 list upcharge 				

MODULAR

BRIDGES II

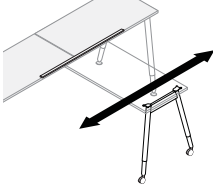
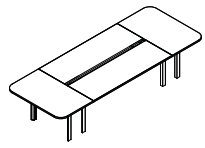
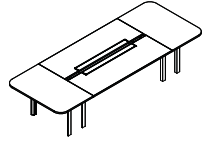
Description	Model Number	Dimensions (inches) d x w x h	Freight Class	Product Wt./Lbs.	Cu. Ft. Per Unit	List Price	HP Add
 <p>Rail Sliding Table Kit - Round Legs Includes leg, leg support, sliding bracket hardware, 72" rail and hardware to secure table. Worksurface not included. Legs are for 24" d worksurfaces. 3" dia. locking casters are standard. Maximum length of sliding table surface is 48".</p>	BRTSLDT72CR	72 x 48 x 29	92.5	28.50	2.40	600	N/A
MEETING TABLES							
 <p>Boardroom Table with Rectangular Leg and Levelers Boardroom Table assemblies consist of 2 or more back-to-back tables with end tables on either side. Inset support legs, levelers. Worksurfaces, supporting structure and connecting hardware included. BRTBRDP276L consists of (6) 24" x 72" back-to-back tables and (2) 30" x 50.5" end tables BRTBRDP240L consists of (6) 24" x 60" back-to-back tables and (2) 30" x 50.5" end tables BRTBRDP204L consists of (4) 24" x 72" back-to-back tables and (2) 30" x 50.5" end tables BRTBRDP180L consists of (4) 24" x 60" back-to-back tables and (2) 30" x 50.5" end tables BRTBRDP132L consists of (2) 24" x 72" back-to-back tables and (2) 30" x 50.5" end tables BRTBRDP120L consists of (2) 24" x 60" back-to-back tables and (2) 30" x 50.5" end tables</p>	BRTBRDP276L	52.5 x 276 x 29	70	474	23.42	6561	819
	BRTBRDP240L	52.5 x 240 x 29	70	408	22.64	6309	765
	BRTBRDP204L	52.5 x 204 x 29	70	340	20.74	5112	603
	BRTBRDP180L	52.5 x 180 x 29	70	308	19.82	4944	567
	BRTBRDP132L	52.5 x 132 x 29	70	228	15.02	3675	387
	BRTBRDP120L	52.5 x 120 x 29	85	210	14.56	3591	369
 <p>Boardroom Table with Rectangular Leg, Access Door and Levelers Boardroom Table assemblies consist of 2 or more back-to-back tables with end tables on either side. Inset support legs, levelers. Worksurfaces, supporting structure and connecting hardware included. BRTBRDP276L consists of (6) 24" x 72" back-to-back tables and (2) 30" x 50.5" end tables BRTBRDP240L consists of (6) 24" x 60" back-to-back tables and (2) 30" x 50.5" end tables BRTBRDP204L consists of (4) 24" x 72" back-to-back tables and (2) 30" x 50.5" end tables BRTBRDP180L consists of (4) 24" x 60" back-to-back tables and (2) 30" x 50.5" end tables BRTBRDP132L consists of (2) 24" x 72" back-to-back tables and (2) 30" x 50.5" end tables BRTBRDP120L consists of (2) 24" x 60" back-to-back tables and (2) 30" x 50.5" end tables Anodized aluminum worksurface door provides access to power/data trough below worksurface. Worksurface with access doors CANNOT be combined with above worksurface power trough.</p>	BRTBRDPA276L	52.5 x 276 x 29	70	474	23.42	6975	1251
	BRTBRDPA240L	52.5 x 240 x 29	70	408	22.64	6735	816
	BRTBRDPA204L	52.5 x 204 x 29	70	340	20.74	5388	651
	BRTBRDPA180L	52.5 x 180 x 29	70	308	19.82	5088	741
	BRTBRDPA132L	52.5 x 132 x 29	70	228	15.02	3783	531
	BRTBRDPA120L	52.5 x 120 x 29	85	210	14.56	3633	456

Required Specifications

- Finish (top)
- Metal Finish (legs)

Optional Specifications

- Anodized Aluminum Leg
Add....\$210.00 list upcharge
- Table Edge mounted Power Module
- Above or Below worksurface Power Trough with Power Distribution Module
- High Pressure Laminate

Required Specifications

- Finish (top)
- Metal Finish (legs)

Optional Specifications

- Anodized Aluminum Leg
Add....\$210.00 list upcharge
- Table Edge mounted Power Module
- Below worksurface Power Trough with Power Distribution Module
- High Pressure Laminate

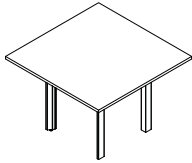
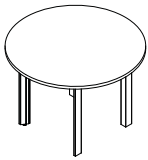
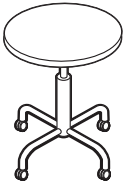
Description	Model Number	Dimensions (inches) d x w x h	Freight Class	Product Wt./Lbs.	Cu. Ft. Per Unit	List Price	HP Add
 <p>Square Meeting Table with Rectangular Legs 3mm edging. Select BRTSQ42L for levelers or BRTSQ42C for casters.</p>	BRTSQ42L	42 x 42 x 29	70	85	4.20	1133	120
	BRTSQ42C	42 x 42 x 29	70	85	4.20	1133	120
 <p>Round Meeting Table with Rectangular Legs 3mm edging. Select BRTR42L for levelers or BRTR42C for casters.</p>	BRTR42L	42 x 42 x 29	70	65	3.90	1133	120
	BRTR42C	42 x 42 x 29	70	65	3.90	1193	120
 <p>Gobie Table The Gobie circular mobile table was designed to create a portable, additional work area for laptops or paperwork. It comes standard with a pneumatic height adjustment allowing it to overlap an existing worksurface, or be tucked below a surface for storage. Tables come standard with 4 prong base and non-locking casters. Pneumatic lift provides a height adjustment between 24" and 34". Non-ganging. Shipped Fully assembled. 3" diameter casters. Matches round leg option.</p>	BRT24GOBE	24 x 24 x 25-35	250	25	9.50	660	35

Required Specifications

- Finish (top)
- Metal Finish (legs)

Optional Specifications

- Anodized Aluminum Leg
Add...\$105.00 list upcharge
- High Pressure Laminate

Required Specifications

- Finish (top)
- Metal Finish (legs)

Optional Specifications



- Anodized Aluminum Leg
Add...\$105.00 list upcharge
- High Pressure Laminate

Required Specifications

- Finish (top)
- Metal Finish (legs)

Optional Specifications

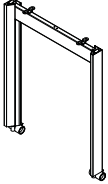
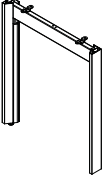
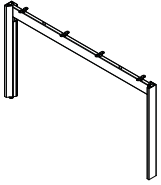
- High Pressure Laminate

Description	Model Number	Dimensions (inches) d x w x h	Freight Class	Product Wt./Lbs.	Cu. Ft. Per Unit	List Price	HP Add
LEG ASSEMBLIES							
	BRTSL24C	24 x 2.5 x 29	150	8	1.34	330	N/A
	BRTSL30C	30 x 2.5 x 29	150	8	1.41	375	N/A
	BRTSL24C42	24 x 2.5 x 42	250	8	2.11	360	N/A
	BRTSL30C42	30 x 2.5 x 42	250	8	2.18	405	N/A
<p>Single Rectangular Leg Assembly with Casters</p> <p>Two single leg assemblies combined with support beams form the structure of the Bridges II series Single Table. One leg can be shared by two adjoining worksurfaces. 40mm white locking casters with grey tires; steel horizontal beams, aluminum legs.</p>	<p>Required Specifications</p> <ul style="list-style-type: none"> ■ Metal Finish (legs) 	<p>Optional Specifications</p> <ul style="list-style-type: none"> ○ Anodized Aluminum Leg Add...\$52.00 list upcharge 					
	BRTSL24L	24 x 2.5 x 29	150	8	1.34	300	N/A
	BRTSL30L	30 x 2.5 x 29	150	8	1.34	330	N/A
	BRTSL24L42	24 x 2.5 x 42	150	8	1.34	315	N/A
	BRTSL30L42	30 x 2.5 x 42	150	8	1.34	345	N/A
<p>Single Rectangular Leg Assembly with Levelers</p> <p>Two single table leg assemblies combined with support beams form the structure of the Bridges II series Single Table. One leg can be shared by two adjoining worksurfaces. Leveling glides; steel horizontal beams, aluminum legs.</p>	<p>Required Specifications</p> <ul style="list-style-type: none"> ■ Metal Finish (legs) 	<p>Optional Specifications</p> <ul style="list-style-type: none"> ○ Anodized Aluminum Leg Add...\$52.00 list upcharge 					
	BRBA34L	34 x 2.5 x 29	150	10	2.47	360	N/A
	BRBA51L	50.5 x 2.5 x 29	150	12	2.96	390	N/A
	BRBA63L	63 x 2.5 x 29	150	13	3.21	405	N/A
<p>Back-to-Back Rectangular Leg Assembly with Levelers</p> <p>Two double leg table assemblies combined with support beams form the structure of the Bridges II Back-to-Back Table. One double leg can be shared by four adjoining worksurfaces. Leveling glides; steel horizontal beams, aluminum legs.</p>	<p>Required Specifications</p> <ul style="list-style-type: none"> ■ Metal Finish (legs) 	<p>Optional Specifications</p> <ul style="list-style-type: none"> ○ Anodized Aluminum Leg Add...\$52.00 list upcharge 					
	BRT120L	34 x 2.5 x 29	250	6.60	2.80	690	N/A
<p>120° Rectangular Corner Leg Kit</p> <p>One 120° corner leg kit combined with two single or double leg assemblies and support beams form the structure of the Bridges II 120° Tables. 120° corner leg kit includes one corner leg and adjacent, telescopic beams to support BRTWAC120xxxx or BRTWAC120xxxxA 120° worksurfaces. Telescopic horizontal beams allow single or double leg assemblies to be positioned either under the worksurface (end of a run) or to be shared by adjoining worksurfaces. Levelers, steel horizontal beams, aluminum legs.</p>	<p>Required Specifications</p> <ul style="list-style-type: none"> ■ Metal Finish (legs) 	<p>Optional Specifications</p> <ul style="list-style-type: none"> ○ Anodized Aluminum Leg Add...\$30.00 list upcharge 					

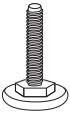
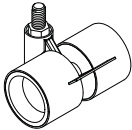
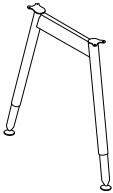
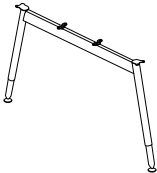
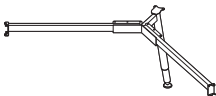
Description	Model Number	Dimensions (inches) d x w x h	Freight Class	Product Wt./Lbs.	Cu. Ft. Per Unit	List Price	HP Add
 <p>Leveler for Rectangular Leg Table 5/16" thread with black base. Leveler has 2" adjustment range. Casters and levelers on Rectangular legs cannot be interchanged on site.</p>	BRTLVS	1 x 1 x 2.5	70	.03	.01	5	N/A
 <p>Caster for Rectangular Leg Table Locking. 40mm diameter with 8mm thread, white body, light grey tires. Casters and levelers on Rectangular legs cannot be interchanged on site.</p>	BRTLCS	2.6 x 2.7 x 2.5	70	.06	.01	24	N/A
 <p>Single Table Round Leg Assembly Two single table leg assemblies combined with a single beam form the supporting structure of the Bridges II series Single Line Table. One leg can be shared by two adjoining worksurfaces. Leveling Glides are standard. Locking casters are available on single tables. Specify BRTLCLCR.</p>	BRTSL	24 x 3 x 28	125	8	1.25	318	N/A
<p>Required Specifications</p> <ul style="list-style-type: none"> ■ Metal Finish (legs) 							
<p>Optional Specifications</p> <ul style="list-style-type: none"> ○ Casters 							
 <p>Double Table Round Leg Assembly Two double table leg assemblies combined with two single beams form the supporting structure of the Bridges II series Back-to-Back Tables. One leg can be shared by two adjoining worksurfaces. Leveling Glides are standard.</p>	BRTDL	50 x 3 x 28	150	12	2.81	414	N/A
<p>Required Specifications</p> <ul style="list-style-type: none"> ■ Metal Finish (legs) 							
 <p>120° Round Corner Leg Assembly Provides support for worksurfaces connected at 120°. Single leg and beam assembly for 120° worksurface planning. Works with BRTWAC120xxxx or BRTWAC120xxxxA 120° worksurfaces. For a single application, two BRTSL (single legs) must be added. To join a back-to-back table application, leg assembly will join to existing pod.</p> <ul style="list-style-type: none"> • When joining to an existing table, the beam extends to reach the shared leg. 	BRTCRL42	34 x 2.5 x 29	92.5	15	1.50	638	N/A
<p>Required Specifications</p> <ul style="list-style-type: none"> ■ Metal Finish (legs) 							

MODULAR

BRIDGES II

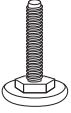
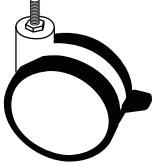
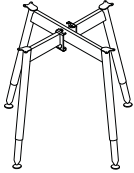
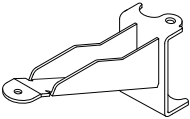
Description	Model Number	Dimensions (inches) d x w x h	Freight Class	Product Wt./Lbs.	Cu. Ft. Per Unit	List Price	HP Add
 <p>Leveler for Round Leg Table 3/8" thread with black base. Leveler has 1" height adjustment range. Field retrofitable on round leg.</p>	BRTLVR	2.125 x 2.125 x 2	70	.20	.01	5	N/A
 <p>Caster for Round Leg Table Locking. 3" diameter with 3/8" -16 threaded stem. Field retrofitable on round leg</p>	BRTLCR	1.5 x 3 x 3.75	70	.30	.01	24	N/A
 <p>Round Table Leg Assembly Four leg assembly. Leveling Glides are standard. Locking casters are available. Specify (4) BRTLCR. Maximum table diameter is 42". Includes all connecting hardware.</p>	BRTL	24 x 24 x 28	125	16	2.33	657	N/A
		<p>Required Specifications</p> <ul style="list-style-type: none"> <input checked="" type="checkbox"/> Metal Finish (legs) 					
		<p>Optional Specifications</p> <ul style="list-style-type: none"> <input type="checkbox"/> Casters 					
 <p>Leg Support Cantilever Provides stability for leg supports.</p>	BRTLSC	2 x 9 x 5	70	.50	.01	111	
		<p>Required Specifications</p> <ul style="list-style-type: none"> <input checked="" type="checkbox"/> Metal Finish 					

Description	Model Number	Dimensions (inches) d x w x h	Freight Class	Product Wt./Lbs.	Cu. Ft. Per Unit	List Price	HP Add
-------------	--------------	----------------------------------	---------------	------------------	------------------	------------	--------

BEAM APPLICATIONS

Table supporting structures - BEAMS

Legs are connected with supporting beams. There is one beam for a single line of tables while two beams connect back-to-back table structures. There are three types of beams whose application principles are common to building support for single-line and back-to-back table assemblies:

SINGLE TABLE BEAM

Designed to bridge two legs to form support for a single table, or for two back-to-back worksurfaces



END OF RUN TABLE BEAM

Supports table leg assemblies at the end of a table run, with legs on one side tucked under the worksurface. Longer by 2" than the Single Table Beam, thereby positioning one leg assembly so that it supports two adjoining worksurfaces.



INTERCONNECTING TABLE BEAM

A typical, multiple surface run begins with an End of Run beam, continues with Interconnecting beam(s), and finishes with another End of Run beam. Also applies to multiple, back-to-back assemblies. Interconnecting beam is designed to bridge space between two table assemblies. Because the Interconnecting beam is 4" longer than the standard beam, it spreads supporting legs apart so that both could be shared by adjacent worksurfaces.



TELESCOPIC TABLE BEAM

Supports a return connected perpendicularly to a 24" or 30" deep primary worksurface. The Telescopic beam is connected to a single or back-to-back leg on one side and to any worksurface-supporting beam on the opposite side.



STORAGE TABLE BEAM

The Storage beam is connected to a single or back-to-back leg on one side and to the worksurface on the opposite side - thus saving one leg assembly. Worksurface is connected to storage units with included storage brackets. Storage table beam's flexibility allows for a single table application (with the table leg tucked in under the worksurface) as well as for a double table installation (two adjacent tables supported by a shared leg in the middle and two storage cabinets at the opposite ends).

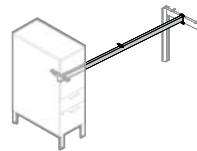

STORAGE TABLE BEAM ADAPTER

Connects to Storage Table Beam. This assembly allows a worksurface to be supported by a leg on one side and a spine (formed by interconnected storage cabinets) on the opposite side.

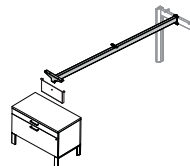

MODULAR

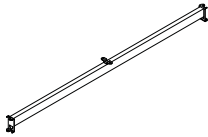
Description	Model Number	Dimensions (inches) d x w x h	Freight Class	Product Wt./Lbs.	Cu. Ft. Per Unit	List Price	HP Add
	BRTSB84	1 x 79 x 2	60	8.02	.15	240	
	BRTSB78	1 x 73 x 2	60	7.38	.12	233	
	BRTSB72	1 x 67 x 2	60	6.74	.09	225	
	BRTSB66	1 x 61 x 2	60	6.09	.08	218	
	BRTSB63	1 x 57.5 x 2	60	5.72	.08	215	
	BRTSB60	1 x 55 x 2	60	5.45	.07	210	
	BRTSB54	1 x 49 x 2	60	4.81	.06	203	
	BRTSB51	1 x 45.5 x 2	60	4.86	.05	195	
	BRTSB48	1 x 43 x 2	60	4.60	.05	188	
	BRTSB42	1 x 37 x 2	60	3.59	.04	180	
	BRTSB36	1 x 31 x 2	60	3.31	.03	177	
	BRTSB24	1 x 19 x 2	60	2.03	.01	173	

Single Table Beam

Supports single table leg assemblies with legs on both sides tucked under the worksurface. Applies to single and back-to-back table assemblies. Specify Single Table Beam size corresponding nominally to the worksurface length. Includes all hardware necessary to connect to legs.

Required Specifications

- Metal Finish

BRIDGES II

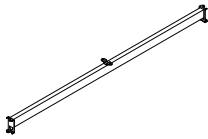
	BRTEB84	1 x 81 x 2	60	8.66	.09	240	
	BRTEB78	1 x 75 x 2	60	8.02	.08	233	
	BRTEB72	1 x 69 x 2	60	7.38	.08	225	
	BRTEB66	1 x 63 x 2	60	6.74	.07	218	
	BRTEB60	1 x 57 x 2	60	6.42	.06	210	
	BRTEB54	1 x 51 x 2	60	5.45	.05	203	
	BRTEB48	1 x 45 x 2	60	4.81	.05	188	
	BRTEB42	1 x 39 x 2	60	4.17	.04	180	
	BRTEB36	1 x 33 x 2	60	3.53	.03	177	
	BRTEB15	1 x 12 x 2	70	1.28	.01	135	

End of Run Table Beam

Supports table leg assemblies at the end of a table run, with legs on one side tucked under the worksurface. Specify End of Run Table Beam size corresponding nominally to the worksurface length. Includes all hardware necessary to connect to legs.

Required Specifications

- Metal Finish

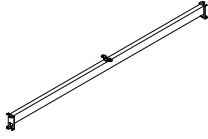
	BRTIB84	1 x 83 x 2	60	8.88	.09	240	
	BRTIB78	1 x 77 x 2	60	8.23	.08	233	
	BRTIB72	1 x 71 x 2	60	7.59	.08	225	
	BRTIB66	1 x 65 x 2	60	6.95	.07	218	
	BRTIB60	1 x 59 x 2	60	6.31	.06	210	
	BRTIB54	1 x 53 x 2	60	5.67	.06	203	
	BRTIB48	1 x 47 x 2	60	5.02	.05	188	
	BRTIB36	1 x 35 x 2	60	3.74	.04	177	

Interconnecting Table Beam

Supports table leg assemblies in the middle of a table run, with legs spanning two adjoining worksurfaces. Specify Interconnecting Table Beam size corresponding nominally to the worksurface length. Includes all hardware necessary to connect to legs.

Required Specifications

- Metal Finish

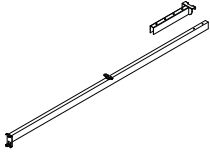
Description	Model Number	Dimensions (inches) d x w x h	Freight Class	Product Wt./Lbs.	Cu. Ft. Per Unit	List Price	HP Add
	BRTTB84	1 x 96.5 x 2	60	10.32	.15	368	
	BRTTB78	1 x 90.5 x 2	60	9.68	.12	360	
	BRTTB72	1 x 84.5 x 2	60	9.04	.09	353	
	BRTTB66	1 x 78.5 x 2	60	8.40	.09	345	
	BRTTB60	1 x 72.5 x 2	60	7.75	.08	338	
	BRTTB54	1 x 66.5 x 2	60	7.11	.07	323	
	BRTTB48	1 x 60.5 x 2	60	6.74	.07	308	
	BRTTB42	1 x 54.5 x 2	60	5.83	.06	293	
	BRTTB36	1 x 48.5 x 2	60	5.19	.05	278	

Telescopic Table Beam

Provides support for a worksurface connected perpendicularly to a run of primary tables. Can be adjusted to accommodate 24" and 30" primary worksurfaces. One end of the beam is attached to a Leg Assembly while the other end is secured, off module to the perpendicular Single, End of Run or Interconnecting Beam. Specify Telescopic Table Beam size corresponding nominally to the return worksurface length.

Required Specifications

- Metal Finish

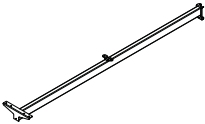
	BRTSTB84	1 x 80.75 x 2	60	8.64	.09	263	
	BRTSTB78	1 x 74.75 x 2	60	7.99	.08	255	
	BRTSTB72	1 x 68.75 x 2	60	7.35	.08	248	
	BRTSTB66	1 x 62.75 x 2	60	6.74	.07	240	
	BRTSTB60	1 x 54.75 x 2	60	5.85	.06	225	
	BRTSTB54	1 x 50.75 x 2	60	5.43	.05	210	
	BRTSTB48	1 x 44.75 x 2	60	4.78	.05	198	
	BRTSTB42	1 x 38.75 x 2	60	4.16	.04	195	
	BRTSTB36	1 x 32.75 x 2	60	3.50	.03	188	

Storage Table Beam

Allows a worksurface to be supported by a leg on one side and storage tower(s) or spine of 21" and 25"h interconnected storage units on the opposite side. Specify Storage Table Beam size corresponding nominally to the worksurface length. Includes all hardware necessary to connect the storage beam to the legs and worksurface.

Required Specifications

- Metal Finish

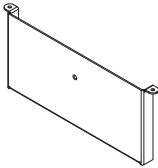
	BRTSA21	1 x 15.2 x 6.5	60	2.15	.05	90	
	BRTSA25	1 x 15.2 x 2.75	60	4.30	.02	75	

Storage Table Beam Adapter

Allows a worksurface to be supported by a leg on one side and storage spine on the opposite side. A typical storage spine is formed by series of Interconnected 21" or 25"h storage cabinets of corresponding depth. The 21" or 25" adaptors provide structural support, acting as supports between the top of the storage cabinet spine and the bottom of the perpendicular worksurfaces. The flexible leg/beam/adaptor assembly arrangement allows the leg to be tucked in under the worksurface or to be shared by two adjacent worksurfaces. Specify Storage Beam nominally 18" shorter than worksurfaces for storage spine support application. Specify BRTSA21 or BRTSA25 depending on height of storage units forming the spine. Includes all hardware necessary to connect the adaptor to the beam, worksurface and storage spine.

Required Specifications

- Metal Finish

MODULAR

Description	Model Number	Dimensions (inches) d x w x h	Freight Class	Product Wt./Lbs.	Cu. Ft. Per Unit	List Price	HP Add
WORKSURFACES							
	BRTWS2484	24 x 84 x 1	60	55	1.80	383	117
	BRTWS2478	24 x 78 x 1	60	51	1.70	354	111
	BRTWS2472	24 x 72 x 1	60	47	1.54	329	108
	BRTWS2466	24 x 66 x 1	60	43	1.41	315	102
	BRTWS2463	24 x 62.5 x 1	65	39	1.41	309	101
	BRTWS2460	24 x 60 x 1	60	39	1.30	302	99
	BRTWS2454	24 x 54 x 1	60	35	1.20	270	86
	BRTWS2451	24 x 50.5 x 1	65	31	1.06	249	81
	BRTWS2448	24 x 48 x 1	65	31	1.06	228	77
	BRTWS2442	24 x 42 x 1	60	28	0.90	191	63
	BRTWS2436	24 x 36 x 1	60	23	0.71	146	48
	BRTWS3084	30 x 84 x 1	60	84	5.20	413	126
	BRTWS3078	30 x 78 x 1	60	81	5.10	371	115
	BRTWS3072	30 x 72 x 1	65	78	5.01	348	113
	BRTWS3066	30 x 66 x 1	60	75	4.90	327	108
	BRTWS3063	30 x 62.5 x 1	65	72	4.80	321	105
	BRTWS3060	30 x 60 x 1	65	69	4.73	315	102
	BRTWS3054	30 x 54 x 1	60	66	4.60	294	86
	BRTWS3051	30 x 50.5 x 1	65	63	4.50	282	89
	BRTWS3048	30 x 48 x 1	65	60	4.41	270	86
	BRTWS3042	30 x 42 x 1	60	57	4.30	255	83
	BRTWS3036	30 x 36 x 1	65	54	4.20	180	59

Rectangular Worksurface
Flat 3 mm edge profile on all sides.

Required Specifications

■ Finish (top)

Optional Specifications

○ High Pressure Laminate

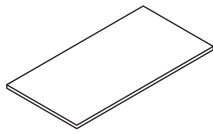

BRIDGES II

	BRTWSA2484	24 x 84 x 1	60	55	1.80	435	210
	BRTWSA2478	24 x 78 x 1	60	51	1.70	413	187
	BRTWSA2472	24 x 72 x 1	60	47	1.54	398	180
	BRTWSA2466	24 x 66 x 1	60	43	1.41	368	157
	BRTWSA2460	24 x 60 x 1	60	39	1.30	338	142
	BRTWSA2454	24 x 54 x 1	60	35	1.20	300	135
	BRTWSA2448	24 x 48 x 1	65	31	1.06	270	120
	BRTWSA2442	24 x 42 x 1	60	28	0.90	240	105
	BRTWSA3084	30 x 84 x 1	60	69	2.24	518	255
	BRTWSA3078	30 x 78 x 1	60	64	2.10	488	240
	BRTWSA3072	30 x 72 x 1	65	59	2.00	473	217
	BRTWSA3066	30 x 66 x 1	60	54	1.80	443	195
	BRTWSA3060	30 x 60 x 1	65	49	1.77	398	180
	BRTWSA3054	30 x 54 x 1	60	44	1.44	360	165
	BRTWSA3048	30 x 48 x 1	65	39	1.41	323	142
	BRTWSA3042	30 x 42 x 1	60	34	1.12	285	128

Rectangular Worksurface with Access Door

Flat 3 mm edge profile on all sides. Worksurfaces 42" to 72" w have one access door. 78" w and 84" w worksurfaces have two access doors. Access door is offset 13.5" from either side of worksurface.

Anodized aluminum worksurface door provides access to power/data trough below worksurface. Worksurface with access doors CANNOT be combined with above worksurface power trough

Required Specifications

■ Finish (top)

Optional Specifications

○ High Pressure Laminate

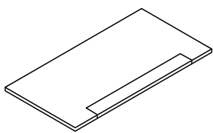

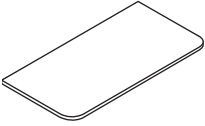
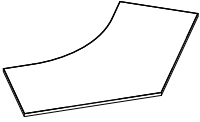
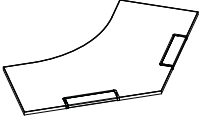
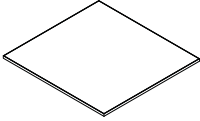
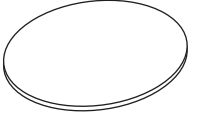
Description	Model Number	Dimensions (inches) d x w x h	Freight Class	Product Wt./Lbs.	Cu. Ft. Per Unit	List Price	HP Add
 <p>Rectangular Boardroom Table Top Extension, Round Corners Flat 3 mm edge profile on all sides. Boardroom table extensions convert existing 24" or 30" deep back-to-back Bridges table assembly into a boardroom table. 24" and 30" d rectangular top with round corner can only be supported by 34" double leg and extension beams. <i>No freestanding and mobile application.</i></p>	BRTWBE2451R	24 x 50.5 x 1	65	31	1.06	270	86
	BRTWBE2463R	24 x 62.5 x 1	65	39	1.41	315	102
	BRTWBE3051R	30 x 50.5 x 1	65	39	1.41	294	86
	BRTWBE3063R	30 x 62.5 x 1	65	49	1.77	327	108
	Required Specifications	Optional Specifications					
	■ Finish (top)	● High Pressure Laminate					
 <p>120° Worksurface 5-sided worksurface can be used for a single, freestanding table, can form a pod of two or three tables, or can be combined with rectangular worksurfaces to create a larger workstation.</p>	BRTWAC120424224	24 x 42 x 1	65	31	1.06	683	223
	BRTWAC120424230	30 x 42 x 1	65	39	1.41	743	226
	Required Specifications	Optional Specifications					
	■ Finish (top)	● High Pressure Laminate					
 <p>120° Worksurface with Access Door 5-sided worksurface can be used for a single, freestanding table, can form a pod of two or three tables, or can be combined with rectangular worksurfaces to create a larger workstation. Access door is offset 13.5" from either side of worksurface. Anodized aluminum worksurface door provides access to power/data trough below worksurface. Worksurface with access doors CANNOT be combined with above worksurface power trough</p>	BRTWAC120A424224	24 x 42 x 1	65	31	1.06	726	242
	BRTWAC120A424230	30 x 42 x 1	65	39	1.41	785	303
	Required Specifications	Optional Specifications					
	■ Finish (top)	● High Pressure Laminate					
 <p>Rectangular Meeting Table Top 50.5" long side matches 24" d back-to-back table assembly.</p>	BRTMT5151	50.5 x 50.5 x 1	65	55	2.12	540	300
		Required Specifications	Optional Specifications				
	■ Finish (top)	● High Pressure Laminate					
 <p>Round Meeting Table Top</p>	BRTMTR42	42 x 42 x 1	65	40	1.76	360	89
		Required Specifications	Optional Specifications				
	■ Finish (top)	● High Pressure Laminate					

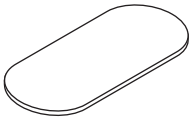
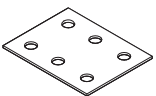
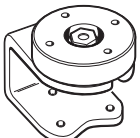
Description	Model Number	Dimensions (inches) d x w x h	Freight Class	Product Wt./Lbs.	Cu. Ft. Per Unit	List Price	HP Add
 <p>Racetrack Table Top For pivoting table.</p>	BRTMTPR2448	24 x 48 x 1	65	31	1.06	228	77
	<p>Required Specifications</p> <ul style="list-style-type: none"> ■ Finish (top) 	<p>Optional Specifications</p> <ul style="list-style-type: none"> ○ High Pressure Laminate 					
 <p>Flat Bracket Constructed of cold rolled steel. May be used to ensure alignment of neighboring worksurfaces</p>	BHBF01	4 x 3 x 0.1	70	.50	.01	14	
 <p>Pivot Clamp Allows table to be clamped to another table top. Specify with oval and round tables only. Clamp allows top to swivel over adjacent surface. 2" difference in height above primary worksurface. Comes standard with oval and round pivoting tables.</p>	BRTCLAMP	3 x 3 x 3	70	.50	.05	156	

Description	Model Number	Dimensions (inches) d x w x h	Freight Class	Product Wt./Lbs.	Cu. Ft. Per Unit	List Price	HP Add
-------------	--------------	----------------------------------	---------------	------------------	------------------	------------	--------

POWER DELIVERY/ CABLE MANAGEMENT

At the basic level, table and floor based office equipment is serviced by a wall or floor power supply. As the operation grows, there might be a need to organize excessive cable clutter.

Wire Basket (1) connects to the underside of worksurfaces with sprig brackets, and cables are simply dropped and coiled into them.

Cable Snake (2) Installed in proximity of floor monument to manage vertical cable clutter..

Table clamped, single circuit **Desk Top Power Data Modules (3)** deliver services to desk height, while tapping into wall or floor power supply. Again, the excessive cables can be managed with Cable Trays.

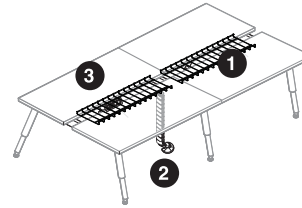

Ceiling pole BRTCPP (4) manages power and data cables between ceiling and above or below worksurface power troughs.

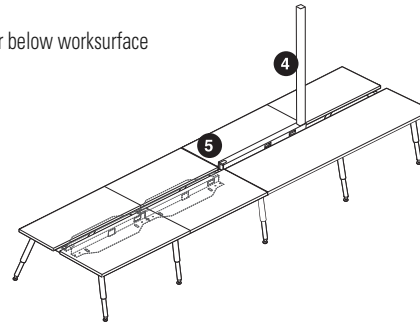

Above and Below Worksurface Power/Data Troughs (5) can be installed between back-to-back tables for extended below and above desk height power/data distribution. 8 wire, 4-circuit system.

Single Sided Power/Data Troughs (6) can be installed to the underside of a single table.

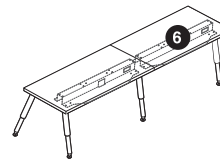

Storage power/data box BRTVCM (7) attaches to storage units and provides access to one duplex/data terminal on top storage surface. Integrated single circuit module can be plugged to floor monument under the storage or to a wall outlet.

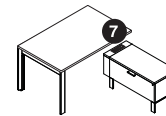

ELECTRICAL SYSTEM

4-2-2 Wiring Schematic

8-Wire Shared Neutral

"2+2" - 2 Utility Circuits, 2 Dedicated

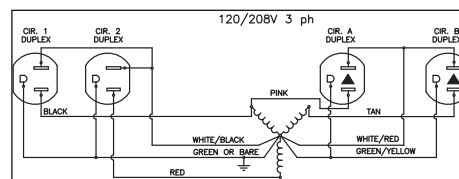
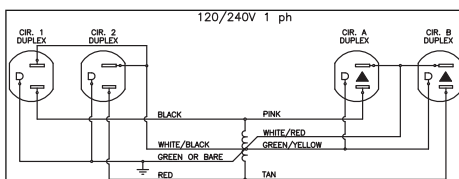

8 Wires

4 lines (12 ga.)
2 Neutrals (10 ga.)
2 Grounds (12 ga.)

4 Circuits

2 Utility circuits
2 Dedicated Circuits

Receptacles

Duplex - Up to 12 duplex receptacles per circuit
(Up to 48 per infeed)

Specifications



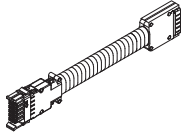
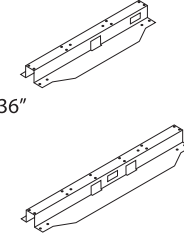
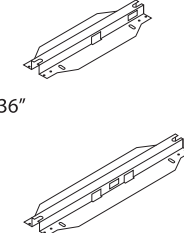

System rated for connection to a grounded 120/240 V single phase, 20A, 60Hz or 120/208 V, 3 phase, 20A, 60Hz branch circuit for U.S. and 15A if product is marked with a C-UL Mark. Outlets rated 15A max.

MODULAR

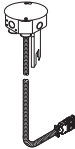
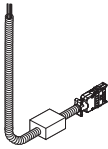
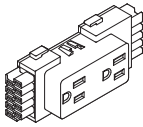

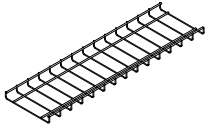
BRIDGES II



Description	Model Number	Dimensions (inches) d x w x h	Freight Class	Product Wt./Lbs.	Cu. Ft. Per Unit	List Price	HP Add
 <p>Transitional Cable The BRT8CT20 connects a BRTEETXXXX kit (which uses a 2+2 system) to an old BR2ETXX Power Trough Kit (which used a 3+1 system). BR2NETXX (OLD NYC Power Trough Kits) do not need a transition jumper as were already a 2+2 system.</p>	BRT8CT20	0.5 x 20 x 2	70	.92	1.17	115	
 <p>36" 42" - 72"</p> <p>Below Worksurface Single Power/Data Trough Formed steel trough is secured below a single table worksurface; outlets are facing the rear worksurface edge. Not suitable for back-to-back tables. Specify Duplex receptacles separately. 36" trough can house one duplex and 42-72" trough can house two duplexes. Specify jumpers between tables separately. Base feed entry at either end; no ceiling feed. Each trough provides one opening at 1.37" x 2.68" for terminal plate (not supplied). One terminal plate can accommodate up to 4 data/communication terminals (jacks). Data/Comm plate spacer (BRTBDS) available to accommodate larger cable-to-cable bending radius. Painted finish.</p> <p>Required Specifications ■ Metal Finish</p> <ul style="list-style-type: none"> BRTEETB36SKIT through BRTEETB72SKIT consist of one single sided steel trough, Power Distribution housing, mounting brackets and one charcoal grey extruded Data/Communication cable manager. BRTEETB78SKIT and BRTEETB84SKIT consist of two single-sided steel troughs, two Power Distribution Housings, mounting brackets and two charcoal grey extruded Data/Communication cable managers. BRTEETB78SKIT includes (1) BRTEETB36SKIT, (1) BRTEETB42SKIT and (1) JUMPER BRTEETB84SKIT includes (2) BRTEETB42SKIT and (1) JUMPER 	BRTEETB84SKIT BRTEETB78SKIT BRTEETB72SKIT BRTEETB66SKIT BRTEETB60SKIT BRTEETB54SKIT BRTEETB48SKIT BRTEETB42SKIT BRTEETB36SKIT	11.6 x 78.34 x 2.5 11.6 x 72.34 x 2.5 11.6 x 66.34 x 2.5 11.6 x 60.34 x 2.5 11.6 x 54.34 x 2.5 11.6 x 48.34 x 2.5 11.6 x 42.34 x 2.5 11.6 x 36.34 x 2.5 11.6 x 30.34 x 2.5	100 100 100 100 100 100 100 100 125	12 11 9.8 8.9 8.0 7.1 6.2 5.3 4.5	1.31 1.21 1.11 1.01 .91 .81 .71 .61 .59	870 833 540 525 503 495 473 435 398	
 <p>36" 42" - 72"</p> <p>Below Worksurface Double Power/Data Trough Formed steel trough is secured below worksurface; outlets, between back-to-back stations supported by Double table legs. Not suitable for single table assemblies. Specify Duplex receptacles separately. 36" trough can house one duplex per side and 42-72" trough can house two duplexes per side. Specify jumpers between tables separately. Ceiling feed entry through slots at either end; base feed entry at either end. Each trough provides two openings at 1.37" x 2.68" (one per side) for data/communication terminal plates. A single terminal plate (not supplied) can accommodate up to 4 data/communication plates. Data/Comm plate spacer (BRTBDS) available to accommodate larger cable-to-terminal bending radius. Painted finish.</p> <p>Required Specifications ■ Metal Finish</p> <ul style="list-style-type: none"> BRTEETB36DKIT through BRTEETB72DKIT consist of one double-sided steel trough, Power Distribution Housing, mounting brackets and one charcoal grey extruded Data/Communication cable manager. BRTEETB78DKIT and BRTEETB84DKIT consist of two double-sided steel troughs, two Power Distribution Housings, mounting brackets and two charcoal grey extruded Data/Communication cable managers. BRTEETB78DKIT includes (1) BRTEETB36DKIT, (1) BRTEETB42DKIT and (1) JUMPER BRTEETB84DKIT includes (2) BRTEETB42DKIT and (1) JUMPER 	BRTEETB84DKIT BRTEETB78DKIT BRTEETB72DKIT BRTEETB66DKIT BRTEETB60DKIT BRTEETB54DKIT BRTEETB48DKIT BRTEETB42DKIT BRTEETB36DKIT	11.6 x 78.3 x 2.5 11.6 x 72.3 x 2.5 11.6 x 66.3 x 2.5 11.6 x 60.3 x 2.5 11.6 x 54.3 x 2.5 11.6 x 48.3 x 2.5 11.6 x 42.3 x 2.5 11.6 x 36.3 x 2.5 11.6 x 30.3 x 2.5	92.5 92.5 92.5 92.5 92.5 92.5 92.5 92.5 92.5	9.80 9.0 8.30 7.50 6.80 6.0 5.30 4.50 3.80	.96 .88 .81 .74 .66 .59 .52 .44 .37	1125 1110 653 638 615 600 585 563 548	

Description	Model Number	Dimensions (inches) d x w x h	Freight Class	Product Wt./Lbs.	Cu. Ft. Per Unit	List Price	HP Add
 <p>Ceiling Pole Brings ceiling feed conduit and data cables from the ceiling down to Power Troughs at desk height. Accommodates 10' ceiling heights. Two part construction allows power/data conduit lay-in. Attaches to end of single Power trough or to a junction between two adjacent Power Troughs. Includes mounting hardware and ceiling bezel. Painted Finish.</p>	BRTCPP	1.5 x 4.75 x 99	65	13	.48	225	
	Required Specifications						
	■ Metal Finish						
 <p>Ceiling Feed Provides single power entry from ceiling, through ceiling pole into Power Trough, into Power Distribution Module. An 8 wire (4 circuit) metal conduit harness with included metal junction box for hard wiring to the building power supply above ceiling tile. Must be hard wired to the building power supply by a licensed electrician. Ceiling Pole not included.</p>	BRTECF120 BRTECF144	6 x 6 x 120 6 x 6 x 144	250 250	5 5	2 2	365 405	
 <p>Ceiling Feed - New York Electrical Provides single power entry from ceiling, through ceiling pole into Power Trough, into Power Distribution Module. An 8 wire (4 circuit) metal conduit harness with included metal junction box for hard wiring to the building power supply above ceiling tile. Must be hard wired to the building power supply by a licensed electrician. Ceiling Pole not included.</p>	BRTECFK120 BRTECFK144	6 x 6 x 120 6 x 6 x 144	250 250	5 5	2 2	548 608	
 <p>Duplex Receptacles Snaps into Power Distribution Housing. Up to 13 duplex receptacles per circuit XW identifies white color plastic, all others standard in black.</p>	BRTE8D1 BRTE8D2 BRTE8DA BRTE8DB BRTE8DXW1 BRTE8DXW2 BRTE8DXWA BRTE8DXWB	1.25 x 4.625 x 2 1.25 x 4.625 x 2 1.25 x 4.625 x 2 1.25 x 4.625 x 2 1.25 x 4.625 x 2 1.25 x 4.625 x 2 1.25 x 4.625 x 2 1.25 x 4.625 x 2	70 70 70 70 70 70 70 70	.10 .10 .10 .10 .10 .10 .10 .10	.01 .01 .01 .01 .01 .01 .01 .01	30 30 30 30 42 42 42 42	
	<ul style="list-style-type: none"> • BRTE8D1 / BRTE8DXW1 - Circuit #1 (utility circuit) • BRTE8D2 / BRTE8DXW2 - Circuit #2 (utility circuit) • BRTE8DA / BRTE8DXWA - Circuit A (dedicated circuit) • BRTE8DB / BRTE8DXWB - Circuit B (dedicated circuit) 						

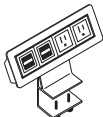
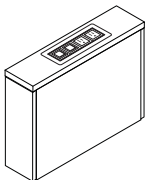
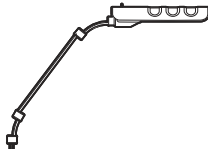

Description	Model Number	Dimensions (inches) d x w x h	Freight Class	Product Wt./Lbs.	Cu. Ft. Per Unit	List Price	HP Add
 <p>Power/Data Cable Basket Shallow, 8" wide basket manages cable excess and serves to manage cords and cables. It can be easily unclipped from spring steel brackets (included) to rearrange cable connections from below worksurface. Spring steel brackets can suspend the Cable Basket below storage cabinet's bottom where it keeps the cords and cables off the floor and manages them under storage cabinets along the horizontal plane - between floor monuments and Storage Vertical Cable Manager, for example. Tall storage cabinet's legs provide easy access to the Cable Basket where it can easily be unclipped from spring steel brackets to rearrange cable connections. Steel wire construction, chrome finish baskets; black spring steel hanging brackets, fasteners.</p>	BRTCB76KIT	8 x 34 x 1	70	1.56	.15	99	
	BRTCB70	8 x 70 x 1	100	3.22	.34	96	
	BRTCB64	8 x 64 x 1	92.5	2.94	.29	93	
	BRTCB58	8 x 58 x 1	92.5	2.66	.26	90	
	BRTCB52	8 x 52 x 1	100	2.39	.24	86	
	BRTCB46	8 x 46 x 1	92.5	2.16	.21	84	
	BRTCB40	8 x 40 x 1	70	1.80	.18	81	
	BRTCB34	8 x 34 x 1	70	1.56	.15	80	
	BRTCB28	8 x 28 x 1	70	1.20	.13	77	
	BRTCB22	8 x 22 x 1	70	1.01	.10	74	
	BRTCB16	8 x 16 x 1	70	0.73	.07	72	
	BRTCB8	8 x 8 x 1	70	0.36	.03	38	
	BRTCS	2 x 8 x 30	70	3	.19	114	
 <p>Cable Snake Flexible cable management trough. Two pathways within the snake, one for data/communication and one for routing power cables. Translucent White finish only.</p>							
 <p>Wire Manager Replacement wire manager can be added. Wire Manager neatly organizes and stores electrical and communication cables. Two lengths: 46" for tops 60" and under; 58" for tops 72". Black Plastic only.</p>	BRTCM43	46 x 5 x 3	92.5	8	.67	44	
	BRTCM55	58 x 5 x 3	92.5	9	.85	53	
 <p>Data/Comm Spacer Data/Comm plate spacer extends the depth behind data/comm jacks by 0.6" in order to accommodate larger data/comm cable bending radius. Black finish.</p>	BRTPDS	0.6 x 4.75 x 2.04	70	.10	.01	42	

- Wide Cable Baskets can span under several storage cabinets. Specify Cable Basket a min. 8" shorter than the storage cabinet spine assembly.

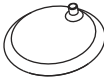
Description	Model Number	Dimensions (inches) d x w x h	Freight Class	Product Wt./Lbs.	Cu. Ft. Per Unit	List Price
 <p>Desktop Power/Data Module Secures to rear edge of worksurface. Provides power - two outlets, 72"L three-prong power cord. Provides data - two coupler/jack ports; includes Voice/Data Adapter Kit to accept various couplers & jacks (not included). Top of module reaches 4" above the worksurface. White face plate, outlets and coupler/jack adapters; anodized aluminum support brackets; thumb screws, black cord.</p>	BRTPDMA	3 x 8 x 6	70	1	.08	660
 <p>Desktop Power/USB Module Secures to rear edge of worksurface. Provides power - two outlets, 72"L three-prong power cord. Provides USB power - 4 USB-A terminals to charge USB devices. USB cables not included. Top of module reaches 4" above the worksurface. White face plate and outlets; anodized aluminum support brackets; thumb screws, black cord.</p>	BRTPDMUA	3 x 8 x 6	70	1	.08	660
 <p>Vertical Cable Manager Facilitates power/data transfer from a floor monument under storage cabinets. The units can join other 18" or 24" deep storage units to form a storage spine. Removable top with a Below worksurface Power/Data Module provides easy access. Optional cable basket suspends off storage unit's bottom and manages cables along the horizontal plane. 1" top, unfinished cut-out edges. Universal connecting hardware included. Below Worksurface Power/Data Module included. Provides power - two outlets; 72"L 3-prong power cord. White face plate, outlets and coupler & jack adapters; anodized aluminum bracket supports; thumb screws, black cord. Provides data - two coupler/jack ports; includes Voice/Data Adapter Kit to accept various couplers & jacks (Not Included)</p>	BRTVCM2118	18 x 6 x 21	92.5	14	1.31	825
	BRTVCM2518	18 x 6 x 25	92.5	17	1.56	840
	BRTVCM2124	24 x 6 x 21	100	17	1.75	870
	BRTVCM2524	24 x 6 x 25	92.5	22	2.08	885
<p>Required Specifications</p> <ul style="list-style-type: none"> ■ Finish (top) ■ Chassis/Accent Finish 						
 <p>Tulip Personal Task Light 13 watt compact fluorescent 3500K lamp with factor plug-in ballast. Includes UV stable silver symmetrical reflector and 8' cord. Specify base seperately. Panel or worksurface mounting options, see below.</p>	BRPT01	7 x 7 x 37	100	5	0.93	346
<p>• Available in Black (BLK) or White (WHT) Only.</p>						
 <p>Task Light Panel Bracket Secures the Tulip Task Light (BRPT01) to the vertical slots of panels. Mounting hardware included.</p>	BRPM01	2.3 x 1.5 x 3.3	100	2	0.007	93
<p>• Available in Black (BLK) Only.</p>						

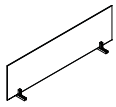
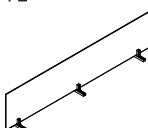
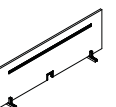
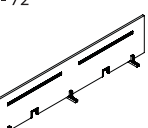
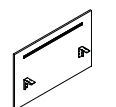
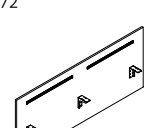
Description	Model Number	Dimensions (inches) d x w x h	Freight Class	Product Wt./Lbs.	Cu. Ft. Per Unit	List Price
 <p>Worksurface Clamp Mount Anodized aluminum bracket secures the Tulip Task Light (BRPT01) to the edge of a worksurface. Mounting hardware included.</p> <ul style="list-style-type: none"> • Available in <i>Black (BLK)</i> or <i>White (WHT)</i> Only. 	BRCMW01	2.3 x 1.5 x 3.3	100	2	0.007	136
 <p>Task Light Bracket Anodized aluminum bracket secures the Tulip Task Light (BRPT01) to the accessory rails/bars/slats of panels. Mounting hardware included.</p> <ul style="list-style-type: none"> • Available in <i>Tungsten (TUN)</i> Only. 	BRTL B	2.3 x 1.5 x 3.3	100	0.50	0.007	90
 <p>Round Freestanding Base Freestanding 7" base supports the Tulip Task Light (BRPT01). Mounting hardware included.</p> <ul style="list-style-type: none"> • Available in <i>Black (BLK)</i> Only. 	BRFB01	7 x 7 x 3.3	150	0.50	0.007	232

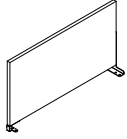
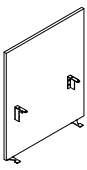
Description	Model Number	Dimensions (inches) d x w x h	Freight Class	Product Wt./Lbs.	Cu. Ft. Per Unit	List Price
ACCESSORIES						
 <p>36" - 72"</p>  <p>78" - 84"</p> <p>Table Divider - Glass Secures between two back-to-back tables; provides privacy, divides space. Installed divider measures 15.7" from the top of the worksurface. 36"-72" wide dividers include 2 support brackets. 78" and 84" wide dividers include 3. Frosted tempered glass, satin chrome/white support brackets.</p>	BRTAGDD84	0.25 x 81 x 16	60	29	.18	668
	BRTAGDD78	0.25 x 75 x 16	60	27	.17	630
	BRTAGDD72	0.25 x 69 x 16	60	25	.16	540
	BRTAGDD66	0.25 x 63 x 16	60	23	.14	503
	BRTAGDD60	0.25 x 57 x 16	60	21	.13	465
	BRTAGDD54	0.25 x 51 x 16	60	18	.11	443
	BRTAGDD48	0.25 x 45 x 16	60	16	.10	405
	BRTAGDD42	0.25 x 39 x 16	60	14	.09	375
	BRTAGDD36	0.25 x 33 x 16	60	12	.07	338
	 <p>36" - 72"</p>  <p>78" - 84"</p> <p>Table Divider - Laminate Secures between two back-to-back tables; provides privacy, divides space. Installed divider measures 15.7" from the top of the worksurface. 36"-72" wide dividers include 2 support brackets and one pass-through grommet. 78" and 84" wide dividers include 3 support brackets and 2 pass-through grommets. 3/4" LP self edged boards. Integrated anodized aluminum accessory rail, white cut out and rail trims; satin chrome/white support brackets.</p>	BRTLPPDD84	0.75 x 81 x 16	60	24	.56
BRTLPPDD78		0.75 x 75 x 16	60	23	.52	443
BRTLPPDD72		0.75 x 69 x 16	60	21	.47	353
BRTLPPDD66		0.75 x 63 x 16	60	19	.43	330
BRTLPPDD60		0.75 x 57 x 16	60	17	.39	315
BRTLPPDD54		0.75 x 51 x 16	60	15	.35	300
BRTLPPDD48		0.75 x 45 x 16	60	14	.31	285
BRTLPPDD42		0.75 x 39 x 16	60	12	.27	263
BRTLPPDD36		0.75 x 33 x 16	60	10	.22	240
Required Specifications ■ Chassis/Accent Finish						
 <p>36" - 72"</p>  <p>78" - 84"</p> <p>High Table Divider - Laminate Installed on one side only. Secures to the back of a single table; provides privacy, divides space. Installed divider measures 15.7" from the top of the worksurface and 15" below the worksurface. 36"-72" wide dividers include 2 support brackets. 78" and 84" wide dividers include 4 support brackets. 3/4" self edged boards. Integrated anodized aluminum accessory rail, white cut out and rail trims; white powder coated brackets. Integrated modesty panel.</p>	BRTLPPDS84	0.75 x 84 x 32	60	50	1.16	720
	BRTLPPDS78	0.75 x 78 x 32	60	47	1.08	690
	BRTLPPDS72	0.75 x 72 x 32	60	43	1	563
	BRTLPPDS66	0.75 x 66 x 32	60	40	.91	533
	BRTLPPDS60	0.75 x 60 x 32	60	36	.83	504
	BRTLPPDS54	0.75 x 54 x 32	60	32	.75	465
	BRTLPPDS48	0.75 x 48 x 32	60	29	.66	443
	BRTLPPDS42	0.75 x 42 x 32	60	25	.56	413
	BRTLPPDS36	0.75 x 36 x 32	60	22	.50	338
	Required Specifications ■ Chassis/Accent Finish					

Description	Model Number	Dimensions (inches) d x w x h	Freight Class	Product Wt./Lbs.	Cu. Ft. Per Unit	List Price
 <p>High Perpendicular Side-to-Side Divider Secures off-module to front and back edges of a table; provides privacy, divides space. Can be installed anywhere along round leg supported worksurfaces. For rectangular leg installation, specify narrow BRTBA34L back-to-back leg if you need to install this divider over the seam of two adjacent worksurfaces. Installed divider measures 15.7" from the top of the worksurface. 3/4" self edged boards. Includes white powder coated steel support brackets.</p>	BRTLPPD24	0.75 x 24 x 16	60	7	.16	165
	BRTLPPD30	0.75 x 30 x 16	60	9	.20	180
	Required Specifications ■ Chassis/Accent Finish					
 <p>Perpendicular End of Run Divider - Laminate Secures to the side edge of a table; provides privacy, divides space. Installed divider measures 15.7" from the top of the worksurface and 15" below the worksurface. Integrated modesty panel. 3/4" self edged boards. Includes white powder coated steel support brackets. For Rectangular leg only.</p>	BRTLPE24	0.75 x 24 x 16	60	7	.16	264
	BRTLPE30	0.75 x 30 x 16	60	9	.20	285
	BRTLPE51	0.75 x 50.5 x 16	60	15	.35	450
	BRTLPE63	0.75 x 62.5 x 16	60	19	.43	510
	Required Specifications ■ Chassis/Accent Finish					
	<ul style="list-style-type: none"> • BRTLPE51 divider matches 24" deep back-to-back assemblies • BRTLPE63 divider matches 30" deep back-to-back assemblies 					
 <p>Table Divider - Fabric Attaches between Back-to-Back Tables for space division and privacy. Includes accessory rail along the top to hang accessories on both sides. Installed dividers measure 16" from the top of the worksurface. 36", 42" and 48" wide dividers include 2 brackets, 54" and 60" wide dividers include 3.</p>	BR2AFD60	1.30 x 60 x 16	92.5	15	1.39	410
	BR2AFD54	1.30 x 54 x 16	92.5	13	1.25	383
	BR2AFD48	1.30 x 48 x 16	85	11	.75	356
	BR2AFD42	1.30 x 42 x 16	100	9	.97	344
	BR2AFD36	1.30 x 36 x 16	100	8	.83	330
	Required Specifications ■ Panel Fabric (pg. 5) ■ Metal Finish					
 <p>Table Divider - Fabric Table Hung Attaches to the rear edge of a table and serves as a privacy/modesty panel. Includes accessory rail along the top to hang accessories on both sides. Installed dividers measure 16" from the top of the worksurface and 15" below the worksurface. FOR ROUND LEG TABLE ASSEMBLIES ONLY.</p>	BR2AHD60	1.30 x 60 x 32	85	36	2.50	549
	BR2AHD54	1.30 x 54 x 32	85	31	2.25	522
	BR2AHD48	1.30 x 48 x 32	85	28	2	500
	BR2AHD42	1.30 x 42 x 32	85	24	1.75	477
	BR2AHD36	1.30 x 36 x 32	85	19	1.50	448
	Required Specifications ■ Panel Fabric (pg. 5) ■ Metal Finish					

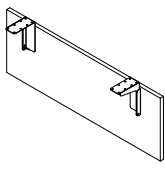
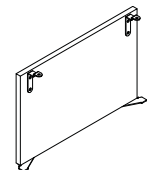
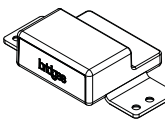
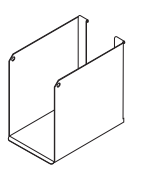
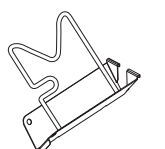
Description	Model Number	Dimensions (inches) d x w x h	Freight Class	Product Wt./Lbs.	Cu. Ft. Per Unit	List Price
 <p>Laminate Modesty Panel Secures to the back edge of a table; provides privacy, divides space. Installed divider measures 15" below the worksurface. 3/4" self edged boards. Flips down for easy access to underside of worksurface. Includes white powder coated steel support brackets.</p>	BRTMPS84	0.75 x 84 x 14	60	22	.51	443
	BRTMPS78	0.75 x 78 x 14	60	20	.47	428
	BRTMPS72	0.75 x 72 x 14	60	19	.43	413
	BRTMPS66	0.75 x 66 x 14	60	17	.40	398
	BRTMPS60	0.75 x 60 x 14	60	16	.36	383
	BRTMPS54	0.75 x 54 x 14	60	14	.32	368
	BRTMPS48	0.75 x 48 x 14	60	13	.29	353
	BRTMPS42	0.75 x 42 x 14	60	11	.25	338
	BRTMPS36	0.75 x 36 x 14	60	9	.21	323
	Required Specifications					
	■ Chassis/Accent Finish					
 <p>Laminate End of Run Gable Perpendicular end of a run gable. Secures to the side edge of a table/tables and legs; provides privacy, divides space. Installed divider measures 15" below the worksurface. 3/4" self edged boards. Includes white powder coated steel support brackets. For Rectangular leg only.</p>	BRTPEG24	0.75 x 24 x 14	60	6	.14	188
	BRTPEG30	0.75 x 30 x 14	60	8	.18	203
	BRTPEG51	0.75 x 50.5 x 14	60	13	.30	330
	BRTPEG63	0.75 x 62.5 x 14	60	16	.38	360
	Required Specifications					
	■ Chassis/Accent Finish					
	BRTTEGF	4.5 x 2.5 x 1.1	70	.03	.01	8
 <p>Table End Gap Filler Injection molded block fills the gap finishing the end of back-to-back table assemblies. Secures to the bottom of two back-to-back worksurfaces. Injection molded resin, white.</p>						
	BABB01	10.25 x 4 x 9	100	2	.21	51
 <p>Binder Bin Load bar/accessory rail mounted metal binder bin.</p>						
	Required Specifications					
	■ Metal Finish					
	BAFS01	9.25 x 2.75 x 9.25	70	.06	.14	38
 <p>Flip Sorter Load bar/accessory rail mounted metal flip sorter. Comes with chrome wire</p>						
	Required Specifications					
	■ Metal Finish					

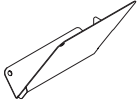
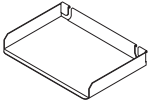
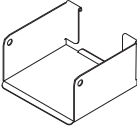
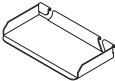
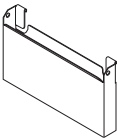
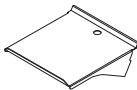
Description	Model Number	Dimensions (inches) d x w x h	Freight Class	Product Wt./Lbs.	Cu. Ft. Per Unit	List Price
 Slant Sorter Load bar/accessory rail mounted metal slant sorter.	BASS01L (Left)	10.25 x 5 x 9.5	70	1	.28	32
	BASS01R (Right)	10.25 x 5 x 9.5	70	1	.28	32
Required Specifications ■ Metal Finish						
 Letter Tray Load bar/accessory rail mounted metal letter tray.	BALT01	9.25 x 13.5 x 2	70	.05	.15	41
	Required Specifications ■ Metal Finish					
 Media Bin Load bar/accessory rail mounted metal media bin.	BAMB01	5.25 x 5.75 x 3	70	.08	.05	41
	Required Specifications ■ Metal Finish					
 Utility Tray Load bar/accessory rail mounted metal utility tray.	BAUT01	3.75 x 8.5 x 1	70	.05	.02	27
	Required Specifications ■ Metal Finish					
 Mail Box Load bar/accessory rail mounted metal mail box.	BAPP01	2.75 x 16 x 9	100	2	.25	66
	Required Specifications ■ Metal Finish					
 Telephone Holder Load bar/accessory rail mounted metal telephone holder.	BVATH01	10 x 9 x 2	125	2	.26	63
	Required Specifications ■ Metal Finish					

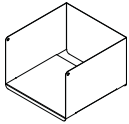
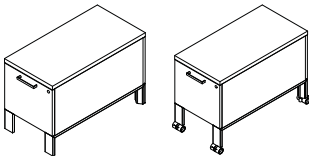
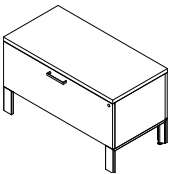
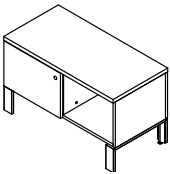
Description	Model Number	Dimensions (inches) d x w x h	Freight Class	Product Wt./Lbs.	Cu. Ft. Per Unit	List Price	HP Add	
 <p>Elevated Shelf Binder Bin Load bar/accessory rail mounted metal elevated shelf binder bin.</p>	BRTESBBIN	12 x 12 x 8	100	6	.66	137		
<p>Required Specifications</p> <ul style="list-style-type: none"> ■ Metal Finish 								
STORAGE								
 <p>File Pedestal Can join with other 21" h storage units of corresponding depth to form a spine or slide out on casters to serve as an additional worksurface. One file drawer. Fits under table beams even with optional seat cushion. Optional cable basket suspends off storage unit's bottom and manages cables and data cables under storage spine. (Leveler models only.) 1" top; metal handles; powder coated aluminum or anodized aluminum legs. Specify "L" models for levelers or "C" models for 40mm white/grey locking casters.</p>	<p>BRT21BF18L BRT21BF24L BRT21BF30L</p> <p>BRT21BF18C BRT21BF24C BRT21BF30C</p>	<p>18 x 15.5 x 21 24 x 15.5 x 21 30 x 15.5 x 21</p> <p>18 x 15.5 x 21 24 x 15.5 x 21 30 x 15.5 x 21</p>	<p>70 85 85</p> <p>70 85 85</p>	<p>58 64 72</p> <p>58 64 72</p>	<p>3.39 4.52 5.65</p> <p>3.39 4.52 5.65</p>	<p>660 765 840</p> <p>660 825 900</p>	<p>45 45 60</p> <p>45 45 60</p>	
<p>Required Specifications</p> <ul style="list-style-type: none"> ■ Finish (top) ■ Chassis/Accent Finish ■ Metal Finish (legs) 		<p>Optional Specifications</p> <ul style="list-style-type: none"> ○ High Pressure Laminate (top only) ○ Cable Basket (pg. 34) ○ Cushion (pg. 45) 		<p>○ Anodized Aluminum Leg Add...\$35.00 list upcharge</p>				
 <p>Lateral File Drawer Can join with other 21" h storage units of corresponding depth to form a spine. One file drawer. Optional 15.5" x 18" cushion. Optional cable basket suspends off storage unit's bottom and manages cables along the horizontal plane. 1" top; metal handles; powder coated aluminum or anodized aluminum legs.</p>	<p>BRT21F30L BRT21F36L BRT21F42L</p>	<p>18 x 30 x 21 18 x 36 x 21 18 x 42 x 21</p>	<p>92.5 92.5 92.5</p>	<p>77 84 92</p>	<p>6.56 7.87 9.18</p>	<p>885 975 1140</p>	<p>60 75 75</p>	
<p>Required Specifications</p> <ul style="list-style-type: none"> ■ Finish (top) ■ Chassis/Accent Finish ■ Metal Finish (legs) 		<p>Optional Specifications</p> <ul style="list-style-type: none"> ○ High Pressure Laminate (top only) ○ Cable Basket (pg. 34) ○ Cushion (pg. 45) 		<p>○ Anodized Aluminum Leg Add...\$57.00 list upcharge</p>				
 <p>Sliding Door Storage Can join with other 21" h storage units of corresponding depth to form a spine. Optional 15.5" x 18" cushion. Storage compartment internal height: 12.36" Sliding door locks on left side. Optional cable basket suspends off storage unit's bottom and manages cables along the horizontal plane. 1" top; metal handles; powder coated aluminum or anodized aluminum legs.</p>	<p>BRT21LS30L BRT21LS36L BRT21LS42L</p>	<p>18 x 30 x 21 18 x 36 x 21 18 x 42 x 21</p>	<p>100 125 125</p>	<p>53 60 67</p>	<p>6.56 7.87 9.18</p>	<p>720 795 870</p>	<p>60 60 60</p>	
<p>Required Specifications</p> <ul style="list-style-type: none"> ■ Finish (top) ■ Chassis/Accent Finish ■ Metal Finish (legs) 		<p>Optional Specifications</p> <ul style="list-style-type: none"> ○ High Pressure Laminate (top only) ○ Cable Basket (pg. 34) ○ Cushion (pg. 45) 		<p>○ Anodized Aluminum Leg Add...\$57.00 list upcharge</p>				

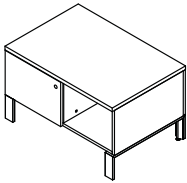
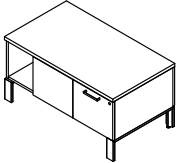
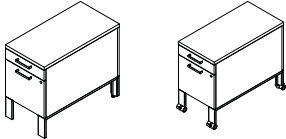
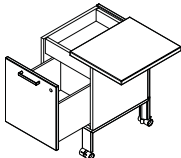
Description	Model Number	Dimensions (inches) d x w x h	Freight Class	Product Wt./Lbs.	Cu. Ft. Per Unit	List Price	HP Add
 <p>Shared Sliding Door Storage Offers two 11" deep storage compartments on either side. For use beside a table assembly, between two adjacent workstations. Can join with other 21"h, 24"d storage units to form a spine. Optional 15.5" x 18" cushion. Storage compartment internal height: 12.36" Sliding door locks on left side. Optional cable basket suspends off storage unit's bottom and manages cables along the horizontal plane. 1" top; metal handles; powder coated aluminum or anodized aluminum legs.</p>	BRT21LSS30L	24 x 30 x 21	125	69	8.75	1005	60
	BRT21LSS36L	24 x 36 x 21	125	78	10.50	1095	75
	BRT21LSS42L	24 x 42 x 21	125	87	12.25	1185	90
	<p>Required Specifications</p> <ul style="list-style-type: none"> ■ Finish (top) ■ Chassis/Accent Finish ■ Metal Finish (legs) <p>Optional Specifications</p> <ul style="list-style-type: none"> ○ High Pressure Laminate (top only) ○ Cable Basket (pg. 34) ○ Cushion (pg. 45) <p>○ Anodized Aluminum Leg Add...\$57.00 list upcharge</p>						
 <p>Shared File/Open Storage Offers storage compartments on either side. For use between two adjacent workstations. Can join with other 21"h, 24"d storage units to form a spine or serve as an additional return worksurface or ad-hoc guest seating with optional 15.5" x 18" cushion. One locking file drawer. One open compartment per side. Storage compartment internal height without shelf: 12.36". Optional cable basket suspends off storage unit's bottom and manages cables along the horizontal plane. 1" top; metal handles; powder coated aluminum or anodized aluminum legs.</p>	BRT21LS042L	24 x 42 x 21	100	124	14	1350	105
	<p>Required Specifications</p> <ul style="list-style-type: none"> ■ Finish (top) ■ Chassis/Accent Finish ■ Metal Finish (legs) <p>Optional Specifications</p> <ul style="list-style-type: none"> ○ High Pressure Laminate (top only) ○ Cable Basket (pg. 34) ○ Cushion (pg. 45) <p>○ Anodized Aluminum Leg Add...\$57.00 list upcharge</p>						
 <p>Box/File Pedestal Can join with other 25"h storage units of corresponding depth to form a spine or slide out on casters to serve as an additional worksurface. One box drawer, one file drawer. Optional cable basket suspends off storage unit's bottom and manages cables and data cables under storage spine. (Leveler models only.) 1" top; metal handles; powder coated aluminum or anodized aluminum legs. Specify "L" models for levelers or "C" models for 40mm white/grey locking casters.</p>	BRT25BF18L	18 x 15.5 x 25	70	69	3.89	750	45
	BRT25BF24L	24 x 15.5 x 25	85	74	5.02	870	45
	BRT25BF30L	30 x 15.5 x 25	85	82	6.15	945	60
	BRT25BF18C	18 x 15.5 x 25	70	69	3.89	810	45
	BRT25BF24C	24 x 15.5 x 25	85	74	5.02	930	45
	BRT25BF30C	30 x 15.5 x 25	85	82	6.15	1005	60
<p>Required Specifications</p> <ul style="list-style-type: none"> ■ Finish (top) ■ Chassis/Accent Finish ■ Metal Finish (legs) <p>Optional Specifications</p> <ul style="list-style-type: none"> ○ High Pressure Laminate (top only) ○ Cable Basket (pg. 34) ○ Anodized Aluminum Leg Add...\$57.00 list upcharge 							
 <p>Toto 2 Mobile Pedestal The top slides sideways in either direction to access a laptop storage compartment and doubles as an additional worksurface. Fits below tables. One box-size compartment, one file drawer. 1" top; metal handles; powder coated aluminum or anodized aluminum legs. Specify "L" models for levelers or "C" models for 40mm white/grey locking casters.</p>	BRTT0T0C	18 x 15.5 x 25	70	69	4.03	1065	60
	<p>Required Specifications</p> <ul style="list-style-type: none"> ■ Finish (top) ■ Chassis/Accent Finish ■ Metal Finish (legs) <p>Optional Specifications</p> <ul style="list-style-type: none"> ○ High Pressure Laminate (top only) ○ Anodized Aluminum Leg Add...\$57.00 list upcharge 						

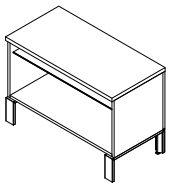
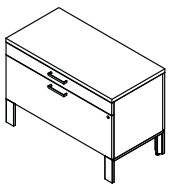
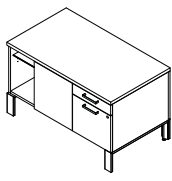
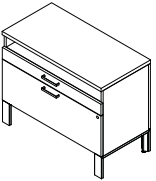
Description	Model Number	Dimensions (inches) d x w x h	Freight Class	Product Wt./Lbs.	Cu. Ft. Per Unit	List Price	HP Add
 <p>Open Storage One adjustable shelf. Positioned beside a table assembly or between two adjacent workstations. Can join with other 25”h, 18”d storage units to form a storage spine, credenza or serve as an additional return worksurface. Open compartment with glass adjustable shelf. Storage compartment internal height without shelf: 15.8” Optional cable basket suspends off storage unit’s bottom and manages cables along the horizontal plane. 1” top; metal handles; powder coated aluminum or anodized aluminum legs.</p>	BRT25LO30L	18 x 30 x 25	125	49	7.81	525	105
	BRT25LO36L	18 x 36 x 25	150	55	9.37	660	60
	BRT25LO42L	18 x 42 x 25	150	62	10.93	720	75
	Required Specifications	Optional Specifications					
	<ul style="list-style-type: none"> ■ Finish (top) ■ Chassis/Accent Finish ■ Metal Finish (legs) 	<ul style="list-style-type: none"> ○ High Pressure Laminate (top only) ○ Cable Basket (pg. 34) 			<ul style="list-style-type: none"> ○ Anodized Aluminum Leg Add...\$57.00 list upcharge 		
 <p>Lateral Box-File Storage Unit Positioned beside a table assembly or between two adjacent workstations. Can join with other 25”h, 18”d storage units to form a storage spine, credenza or serve as an additional return worksurface. One locking file drawer, one box drawer. Optional cable basket suspends off storage unit’s bottom and manages cables along the horizontal plane. 1” top; metal handles; powder coated aluminum or anodized aluminum legs.</p>	BRT25LBF30L	18 x 30 x 25	92.5	88	7.81	1020	60
	BRT25LBF36L	18 x 36 x 25	92.5	96	9.37	1170	60
	BRT25LBF42L	18 x 42 x 25	100	104	10.93	1275	75
	Required Specifications	Optional Specifications					
	<ul style="list-style-type: none"> ■ Finish (top) ■ Chassis/Accent Finish ■ Metal Finish (legs) 	<ul style="list-style-type: none"> ○ High Pressure Laminate (top only) ○ Cable Basket (pg. 34) 			<ul style="list-style-type: none"> ○ Anodized Aluminum Leg Add...\$57.00 list upcharge 		
 <p>Shared Storage Unit Offers storage compartments on either side. For use between two adjacent workstations. Can join with other 25”h, 24”d storage units to form a storage spine or serve as an additional return worksurface. One locking file drawer, one box drawer, one open compartment with adjustable shelf per side. Storage compartment internal height without shelf: 16.08”. Optional cable basket suspends off storage unit’s bottom and manages cables along the horizontal plane. 1” top; metal handles; powder coated aluminum or anodized aluminum legs.</p>	BRT25LBF042L	24 x 42 x 25	100	154	16.66	1695	90
	Required Specifications	Optional Specifications					
	<ul style="list-style-type: none"> ■ Finish (top) ■ Chassis/Accent Finish ■ Metal Finish (legs) 	<ul style="list-style-type: none"> ○ High Pressure Laminate (top only) ○ Cable Basket (pg. 34) 			<ul style="list-style-type: none"> ○ Anodized Aluminum Leg Add...\$57.00 list upcharge 		
 <p>Lateral Box-File Open Storage Unit Positioned beside a table assembly or between two adjacent workstations. Units are level with Bridges tops and can join other 29”h, 18”d storage units to form a credenza or serve as an additional return worksurface. One locking file drawer, one box drawer, one open compartment. Storage compartment internal height: 3.9”. Optional cable basket suspends off storage unit’s bottom and manages cables along the horizontal plane. 1” top; metal handles; powder coated aluminum or anodized aluminum legs.</p>	BRT29LOBF30L	18 x 30 x 29	92.5	100	9.06	1164	51
	BRT29LOBF36L	18 x 36 x 29	92.5	111	10.87	1305	75
	BRT29LOBF42L	18 x 42 x 29	100	122	12.68	1455	90
	Required Specifications	Optional Specifications					
	<ul style="list-style-type: none"> ■ Finish (top) ■ Chassis/Accent Finish ■ Metal Finish (legs) 	<ul style="list-style-type: none"> ○ High Pressure Laminate (top only) ○ Cable Basket (pg. 34) 			<ul style="list-style-type: none"> ○ Anodized Aluminum Leg Add...\$57.00 list upcharge 		

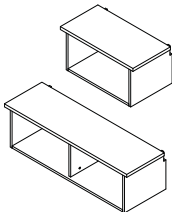
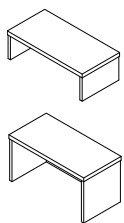
Description	Model Number	Dimensions (inches) d x w x h	Freight Class	Product Wt./Lbs.	Cu. Ft. Per Unit	List Price	HP Add
 <p>Table Mounted End Shelf Single or double open shelf/extended workspace. Secured to the end of single or back-to-back Bridges table. All mounting hardware included. Storage compartment internal height: 13.25". 1" top.</p>	BRTTES24	15.5 x 24 x 15	100	29	3.22	555	45
	BRTTES30	15.5 x 30 x 15	100	34	4.03	608	52
	BRTTES51	15.5 x 50.5 x 15	100	57	6.79	1005	98
	BRTTES63	15.5 x 62.5 x 15	100	68	8.40	1103	127
 <p>Single Sided Elevated Table Shelf Secured perpendicularly to the single or back-to-back Bridges table. Integrated anodized aluminum accessory rail. White cut out and accessory rail trims. Optional Elevated Shelf Binder Bin (BRTESBBIN) rests on top surface for enhanced privacy. 8"h provides additional storage space without obstructing view and reaches 16" module height when combined w/8"h Binder shelf. Internal height: 6.6". 16"h lines up with top of 16" table dividers (15.8"). Specify 12" narrower shared elevated shelf immediately adjacent to the perpendicular elevated shelf. Internal height: 14.6".</p>	BRTSTS0824	12 x 24 x 8	92.5	14	1.33	195	60
	BRTSTS0830	12 x 30 x 8	100	16	1.66	225	60
	BRTSTS0851	12 x 50.5 x 8	100	25	2.80	360	90
	BRTSTS0863	12 x 62.5 x 8	100	28	3.47	405	135
	BRTSTS1324	12 x 24 x 13	100	18	2.16	210	60
	BRTSTS1330	12 x 30 x 13	125	21	2.70	240	60
	BRTSTS1351	12 x 50.5 x 13	125	32	4.55	360	90
	BRTSTS1363	12 x 62.5 x 13	125	38	5.64	420	120
	BRTSTS1624	12 x 24 x 16	125	19	2.66	240	60
	BRTSTS1630	12 x 30 x 16	100	29	3.33	285	60
	BRTSTS1651	12 x 50.5 x 16	150	33	5.61	420	105
	BRTSTS1663	12 x 62.5 x 16	150	39	6.94	480	135

Required Specifications

- Finish (top)
- Chassis/Accent Finish

Optional Specifications

- High Pressure Laminate (top only)

Required Specifications

- Finish (top)
- Chassis/Accent Finish

Optional Specifications

- High Pressure Laminate
- Elevated Shelf Binder Bin (pg. 39)

MODULAR

Description	Model Number	Dimensions (inches) d x w x h	Freight Class	Product Wt./Lbs.	Cu. Ft. Per Unit	List Price	HP Add
	BRTBTS0836	12 x 36 x 8	100	16	2.00	300	60
	BRTBTS0842	12 x 42 x 8	100	19	2.33	330	60
	BRTBTS0848	12 x 48 x 8	125	21	2.66	360	90
	BRTBTS0854	12 x 54 x 8	125	23	3.00	375	105
	BRTBTS0860	12 x 60 x 8	125	26	3.33	420	120
	BRTBTS0866	12 x 66 x 8	125	28	3.66	450	135
	BRTBTS0872	12 x 72 x 8	125	30	4.00	480	135
	BRTBTS0878	12 x 78 x 8	125	32	4.33	510	150
	BRTBTS0884	12 x 84 x 8	125	35	4.66	540	165
	BRTBTS1336	12 x 36 x 13	125	22	3.25	360	75
	BRTBTS1342	12 x 42 x 13	125	25	3.79	405	75
	BRTBTS1348	12 x 48 x 13	125	28	4.33	435	105
	BRTBTS1354	12 x 54 x 13	125	30	4.87	480	105
	BRTBTS1360	12 x 60 x 13	150	33	5.86	510	105
	BRTBTS1366	12 x 66 x 13	150	36	6.45	525	180
	BRTBTS1372	12 x 72 x 13	125	39	6.50	600	150
	BRTBTS1378	12 x 78 x 13	150	42	7.04	645	150
	BRTBTS1384	12 x 84 x 13	150	44	7.58	690	165
	BRTBTS1636	12 x 36 x 16	125	25	4.00	375	60
	BRTBTS1642	12 x 42 x 16	125	28	4.66	420	90
	BRTBTS1648	12 x 48 x 16	150	31	5.33	465	90
	BRTBTS1654	12 x 54 x 16	150	34	6.00	495	120
	BRTBTS1660	12 x 60 x 16	150	38	6.66	540	120
	BRTBTS1666	12 x 66 x 16	150	41	7.33	630	120
	BRTBTS1672	12 x 72 x 16	150	44	8.00	660	135
	BRTBTS1678	12 x 78 x 16	150	47	8.66	660	150
	BRTBTS1684	12 x 84 x 16	150	50	9.33	705	165

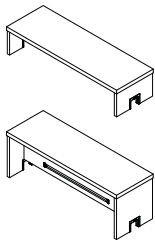

Shared Elevated Table Shelf

Rests on back-to-back Bridges tables. Cut outs in both supporting side gables allow placement over above worksurface power/data troughs. Integrated anodized aluminum accessory rail. White cut out and accessory rail trims. Three heights available. 8" h provides additional storage space without obstructing view; reaches 16" module height when combined w/8" h Binder shelf. Internal height: 6.6". 16" h lines up with top of 16" table dividers (15.8"). Specify 12" narrower shared elevated shelf immediately adjacent to the perpendicular elevated shelf. Internal height: 14.6". Optional Elevated Shelf Binder Bin (BRTESBBIN) rests on top surface for enhanced privacy. 1" top.

Required Specifications

- Finish (top)
- Chassis/Accent Finish

Optional Specifications

- High Pressure Laminate (top only)
- Elevated Shelf Binder Bin (pg. 39)

BRIDGES II

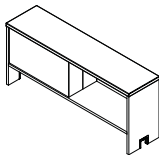

Table Supported Shared Overhead

One compartment per side. White magnetic back wall. Lines up with 50" h floor standing storage. Fits over the gap between two parallel back-to-back Bridges tables. Fits over worksurface power/data trough. Storage compartment internal height: 12.8". Optional Elevated Shelf Binder Bin (BRTESBBIN) rests on top surface for enhanced privacy. 1" top.

Required Specifications

- Finish (top)
- Chassis/Accent Finish

Optional Specifications

- High Pressure Laminate (top only)
- Elevated Shelf Binder Bin (pg. 39)

	BRTBAS048	12 x 48 x 21	125	54	7	600	90
--	-----------	--------------	-----	----	---	-----	----

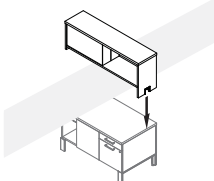
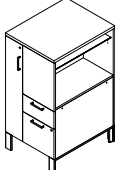
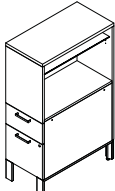
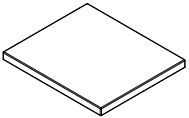
Description	Model Number	Dimensions (inches) d x w x h	Freight Class	Product Wt./Lbs.	Cu. Ft. Per Unit	List Price	HP Add
 <p>45" High Shared Storage Divider Divides side-to-side workstations. Two shared, open shelves. One compartment per side. White magnetic back wall. Rests on top of shared 25" box/file/open and back-to-back worksurface. Top of unit is 15.7" from the top of the worksurface. Storage compartment internal height: 12.8". Optional Elevated Shelf Binder Bin (BRTESBBIN) rests on top surface for enhanced privacy. 1" top, white powder-coated steel central partition and backs.</p>	BRTSDS48	12 x 48 x 16	92.5	54	5.33	480	90
<p>Required Specifications</p> <ul style="list-style-type: none"> ■ Finish (top) ■ Chassis/Accent Finish <p>Optional Specifications</p> <ul style="list-style-type: none"> ○ High Pressure Laminate (top only) ○ Elevated Shelf Binder Bin (pg. 39) 							
 <p>Storage Tower with Coat Storage Provides storage and privacy at the end of a table. Box/File drawers, open compartment with adjustable shelf (50"h); coat storage with hinged door. Specify Left or Right handed. Capable of supporting worksurface on one side. Built-in threaded inserts to secure dedicated worksurface supporting beam. Open side storage compartment internal height: 19.6". Optional cable basket suspends off storage unit's bottom and manages cables along the horizontal plane. 1" top; metal handles; powder-coated aluminum or anodized aluminum legs.</p>	<p>BRTTW5024L BRTTW5024R BRTTW5030L BRTTW5030R</p>	<p>24 x 24 x 50 24 x 24 x 50 30 x 24 x 50 30 x 24 x 50</p>	<p>100 100 125 125</p>	<p>142 142 163 163</p>	<p>16.66 16.66 20.83 20.83</p>	<p>1635 1635 1815 1815</p>	<p>105 105 105 105</p>
<p>Required Specifications</p> <ul style="list-style-type: none"> ■ Finish (top) ■ Chassis/Accent Finish <p>Optional Specifications</p> <ul style="list-style-type: none"> ○ High Pressure Laminate (top only) ○ Cable Basket (pg. 34) ○ Anodized Aluminum Leg Add...\$57.00 list upcharge 							
 <p>Storage Tower Provides storage and privacy at the end of a table. Box/File drawers, open compartment with adjustable glass shelf; Specify Left or Right handed. Capable of supporting worksurface on one side. Built-in threaded inserts to secure dedicated worksurface supporting beam. Open side storage compartment internal height: 19.6". Optional cable basket suspends off storage unit's bottom and manages cables along the horizontal plane. 1" top; metal handles; powder-coated aluminum or anodized aluminum legs.</p>	<p>BRTT5024L BRTT5024R BRTT5030L BRTT5030R</p>	<p>24 x 15.5 x 50 24 x 15.5 x 50 30 x 15.5 x 50 30 x 15.5 x 50</p>	<p>100 100 125 125</p>	<p>88 88 101 101</p>	<p>10.76 10.76 13.45 13.45</p>	<p>1215 1215 1335 1335</p>	<p>75 75 90 90</p>
<p>Required Specifications</p> <ul style="list-style-type: none"> ■ Finish (top) ■ Chassis/Accent Finish <p>Optional Specifications</p> <ul style="list-style-type: none"> ○ High Pressure Laminate (top only) ○ Cable Basket (pg. 34) ○ Anodized Aluminum Leg Add...\$57.00 list upcharge 							
 <p>Cushion Optional seat cushion may be added to any storage component. Available in all Global seating fabrics.</p>	BRTC	18 x 15.5 x 1	70	1	.41	<p>3 194 4 219 5 240 6 266 7 302 8 338</p>	<p>9 374 10 405 11 441 12 479 13 528 14 599</p>
<p>Required Specifications</p> <ul style="list-style-type: none"> ■ Fabric 							

MODULAR

INDEX

BABBO1.....39	BRTAGDD60.....37	BRTBAR4P3072L.....11	BRTBAR6PA3078L.....12	BRTBTS0866.....45	BRTECF120.....33
BAFS01.....39	BRTAGDD66.....37	BRTBAR4P3072LR.....16	BRTBAR6PA3078LR.....17	BRTBTS0872.....8, 45	BRTECF144.....33
BALTO1.....40	BRTAGDD72.....7, 37	BRTBAR4P3078L.....11	BRTBAR6PA3084L.....12	BRTBTS0878.....45	BRTECFK120.....33
BAMB01.....40	BRTAGDD78.....37	BRTBAR4P3078LR.....16	BRTBAR6PA3084LR.....17	BRTBTS0884.....45	BRTECFK144.....33
BAPP01.....40	BRTAGDD84.....37	BRTBAR4P3084L.....11	BRTBAR8P2460L.....13	BRTBTS1336.....45	BRTEETA36KIT.....32
BASSO1L.....40	BRTA34L.....7, 21, 38	BRTBAR4P3084LR.....16	BRTBAR8P2460LR.....17	BRTBTS1342.....45	BRTEETA42KIT.....32
BASSO1R.....40	BRTBA51L.....6, 7, 21	BRTBAR4PA2460L.....12	BRTBAR8P2466L.....13	BRTBTS1348.....45	BRTEETA48KIT.....32
BAUTO1.....40	BRTBA63L.....21	BRTBAR4PA2460LR.....16	BRTBAR8P2466LR.....17	BRTBTS1354.....45	BRTEETA54KIT.....32
BHBF01.....8, 29	BRTBAR2P2460L.....11	BRTBAR4PA2466L.....12	BRTBAR8P2472L.....8, 13	BRTBTS1360.....45	BRTEETA60KIT.....32
BR2AFD36.....38	BRTBAR2P2460LR.....15	BRTBAR4PA2466LR.....16	BRTBAR8P2472LR.....17	BRTBTS1366.....45	BRTEETA66KIT.....32
BR2AFD42.....38	BRTBAR2P2466L.....11	BRTBAR4PA2472L.....12	BRTBAR8P2478L.....13	BRTBTS1372.....45	BRTEETA72KIT.....6, 8, 32
BR2AFD48.....38	BRTBAR2P2466LR.....15	BRTBAR4PA2472LR.....16	BRTBAR8P2478LR.....17	BRTBTS1378.....45	BRTEETA78KIT.....32
BR2AFD54.....38	BRTBAR2P2472L.....11	BRTBAR4PA2478L.....12	BRTBAR8P2484L.....13	BRTBTS1384.....45	BRTEETA84KIT.....32
BR2AFD60.....38	BRTBAR2P2472LR.....15	BRTBAR4PA2478LR.....16	BRTBAR8P2484LR.....17	BRTBTS1636.....45	BRTEETB36DKIT.....31
BR2AHD36.....38	BRTBAR2P2478L.....11	BRTBAR4PA2484L.....12	BRTBAR8P3060L.....13	BRTBTS1642.....45	BRTEETB36SKIT.....31
BR2AHD42.....38	BRTBAR2P2478LR.....15	BRTBAR4PA2484LR.....16	BRTBAR8P3060LR.....17	BRTBTS1648.....45	BRTEETB42DKIT.....31
BR2AHD48.....38	BRTBAR2P2484L.....11	BRTBAR4PA3060L.....12	BRTBAR8P3066L.....13	BRTBTS1654.....45	BRTEETB42SKIT.....31
BR2AHD54.....38	BRTBAR2P2484LR.....15	BRTBAR4PA3060LR.....16	BRTBAR8P3066LR.....17	BRTBTS1660.....45	BRTEETB48DKIT.....31
BR2AHD60.....38	BRTBAR2P3060L.....11	BRTBAR4PA3066L.....12	BRTBAR8P3072L.....13	BRTBTS1666.....45	BRTEETB48SKIT.....31
BRCMWW01.....36	BRTBAR2P3060LR.....15	BRTBAR4PA3066LR.....16	BRTBAR8P3072LR.....17	BRTBTS1672.....6, 45	BRTEETB54DKIT.....31
BRFB01.....36	BRTBAR2P3066L.....11	BRTBAR4PA3072L.....12	BRTBAR8P3078L.....13	BRTBTS1678.....45	BRTEETB54SKIT.....31
BRPM01.....35	BRTBAR2P3066LR.....15	BRTBAR4PA3072LR.....16	BRTBAR8P3078LR.....17	BRTBTS1684.....45	BRTEETB60DKIT.....31
BRPT01.....35, 36	BRTBAR2P3072L.....11	BRTBAR4PA3078L.....12	BRTBAR8P3084L.....13	BRTC.....46	BRTEETB60SKIT.....31
BRT120L.....6, 21	BRTBAR2P3072LR.....15	BRTBAR4PA3078LR.....16	BRTBAR8P3084LR.....17	BRTCB16.....34	BRTEETB66DKIT.....31
BRT21BF18C.....41	BRTBAR2P3078L.....11	BRTBAR4PA3084L.....12	BRTBAR8PA2460L.....13	BRTCB22.....34	BRTEETB66SKIT.....31
BRT21BF18L.....41	BRTBAR2P3078LR.....15	BRTBAR4PA3084LR.....16	BRTBAR8PA2460LR.....18	BRTCB28.....34	BRTEETB72DKIT.....31
BRT21BF24C.....41	BRTBAR2P3084L.....11	BRTBAR6P2460L.....12	BRTBAR8PA2466L.....13	BRTCB34.....34	BRTEETB72SKIT.....31
BRT21BF24L.....41	BRTBAR2P3084LR.....15	BRTBAR6P2460LR.....17	BRTBAR8PA2466LR.....18	BRTCB40.....34	BRTEETB78DKIT.....31
BRT21BF30C.....41	BRTBAR2PA2460L.....11	BRTBAR6P2466L.....12	BRTBAR8PA2472L.....13	BRTCB46.....34	BRTEETB78SKIT.....31
BRT21BF30L.....41	BRTBAR2PA2460LR.....16	BRTBAR6P2466LR.....17	BRTBAR8PA2472LR.....18	BRTCB52.....34	BRTEETB84DKIT.....31
BRT21F30L.....41	BRTBAR2PA2466L.....11	BRTBAR6P2472L.....8, 12	BRTBAR8PA2478L.....13	BRTCB58.....34	BRTEETB84SKIT.....31
BRT21F36L.....41	BRTBAR2PA2466LR.....16	BRTBAR6P2472LR.....17	BRTBAR8PA2478LR.....18	BRTCB64.....34	BRTEHH28.....8, 32
BRT21F42L.....41	BRTBAR2PA2472L.....11	BRTBAR6P2478L.....12	BRTBAR8PA2484L.....13	BRTCB70.....34	BRTEHH40.....32
BRT21LS30L.....41	BRTBAR2PA2472LR.....16	BRTBAR6P2478LR.....17	BRTBAR8PA2484LR.....18	BRTCB76KIT.....34	BRTESBBIN.....41, 44-46
BRT21LS36L.....41	BRTBAR2PA2478L.....11	BRTBAR6P2484L.....12	BRTBAR8PA3060L.....13	BRTCB8.....34	BRTEPEC.....6, 8, 32
BRT21LS42L.....7, 41	BRTBAR2PA2478LR.....16	BRTBAR6P2484LR.....17	BRTBAR8PA3060LR.....18	BRTCLAMP.....29	BRTIB36.....25
BRT21LSO42L.....42	BRTBAR2PA2484L.....11	BRTBAR6P3060L.....12	BRTBAR8PA3066L.....13	BRTCM43.....34	BRTIB42.....25
BRT21LSS30L.....42	BRTBAR2PA2484LR.....16	BRTBAR6P3060LR.....17	BRTBAR8PA3066LR.....18	BRTCM55.....34	BRTIB48.....25
BRT21LSS36L.....42	BRTBAR2PA3060L.....11	BRTBAR6P3066L.....12	BRTBAR8PA3072L.....13	BRTCPP.....30, 33	BRTIB54.....25
BRT21LSS42L.....42	BRTBAR2PA3060LR.....16	BRTBAR6P3066LR.....17	BRTBAR8PA3072LR.....18	BRTCRL42.....22	BRTIB60.....25
BRT24GOBE.....20	BRTBAR2PA3066L.....11	BRTBAR6P3072L.....12	BRTBAR8PA3078L.....13	BRTCS.....34	BRTIB66.....25
BRT25BF18C.....42	BRTBAR2PA3066LR.....16	BRTBAR6P3072LR.....17	BRTBAR8PA3078LR.....18	BRTDL.....22	BRTIB72.....25
BRT25BF18L.....42	BRTBAR2PA3072L.....6, 11	BRTBAR6P3078L.....12	BRTBAR8PA3084L.....13	BRTE8D1.....6, 8, 33	BRTIB78.....25
BRT25BF24C.....42	BRTBAR2PA3072LR.....16	BRTBAR6P3078LR.....17	BRTBAR8PA3084LR.....18	BRTE8D2.....33	BRTIB84.....25
BRT25BF24L.....42	BRTBAR2PA3078L.....11	BRTBAR6P3084L.....12	BRTBASO48.....45	BRTE8DA.....6, 8, 33	BRTL.....36
BRT25BF30C.....42	BRTBAR2PA3078LR.....16	BRTBAR6P3084LR.....17	BRTBRDP120L.....19	BRTE8DB.....33	BRTLCLR.....4, 22, 23
BRT25BF30L.....42	BRTBAR2PA3084L.....11	BRTBAR6PA2460L.....12	BRTBRDP132L.....19	BRTE8DXW1.....33	BRTLCS.....4, 22
BRT25LBF30L.....43	BRTBAR2PA3084LR.....16	BRTBAR6PA2460LR.....17	BRTBRDP180L.....19	BRTE8DXW2.....33	BRTLPPDD36.....37
BRT25LBF36L.....43	BRTBAR4P2460L.....11	BRTBAR6PA2466L.....12	BRTBRDP204L.....19	BRTE8DXWA.....33	BRTLPPDD42.....6, 37
BRT25LBF42L.....7, 8, 43	BRTBAR4P2460LR.....16	BRTBAR6PA2466LR.....17	BRTBRDP240L.....19	BRTE8DXWB.....33	BRTLPPDD48.....37
BRT25LBF042L.....8, 43	BRTBAR4P2466L.....11	BRTBAR6PA2472L.....12	BRTBRDP276L.....19	BRTEB15.....25	BRTLPPDD54.....8, 37
BRT25LO30L.....43	BRTBAR4P2466LR.....16	BRTBAR6PA2472LR.....17	BRTBRDPA120L.....19	BRTEB36.....25	BRTLPPDD60.....8, 37
BRT25LO36L.....43	BRTBAR4P2472L.....6, 11	BRTBAR6PA2478L.....12	BRTBRDPA132L.....19	BRTEB42.....25	BRTLPPDD66.....37
BRT25LO42L.....8, 43	BRTBAR4P2472LR.....16	BRTBAR6PA2478LR.....17	BRTBRDPA180L.....19	BRTEB48.....25	BRTLPPDD72.....37
BRT29LOBF30L.....43	BRTBAR4P2478L.....11	BRTBAR6PA2484L.....12	BRTBRDPA204L.....19	BRTEB54.....25	BRTLPPDD78.....37
BRT29LOBF36L.....8, 43	BRTBAR4P2478LR.....16	BRTBAR6PA2484LR.....17	BRTBRDPA240L.....19	BRTEB60.....25	BRTLPPDD84.....37
BRT29LOBF42L.....43	BRTBAR4P2484L.....11	BRTBAR6PA3060L.....12	BRTBRDPA276L.....19	BRTEB66.....25	BRTLPPDS36.....37
BRT8CT20.....31	BRTBAR4P2484LR.....16	BRTBAR6PA3060LR.....17	BRTBTS0836.....45	BRTEB72.....25	BRTLPPDS42.....37
BRTAGDD36.....37	BRTBAR4P3060L.....11	BRTBAR6PA3066L.....12	BRTBTS0842.....45	BRTEB78.....25	BRTLPPDS48.....37
BRTAGDD42.....37	BRTBAR4P3060LR.....16	BRTBAR6PA3066LR.....17	BRTBTS0848.....7, 45	BRTEB84.....25	BRTLPPDS54.....37
BRTAGDD48.....37	BRTBAR4P3066L.....11	BRTBAR6PA3072L.....12	BRTEBF.....6, 8, 32	BRTEB84.....25	BRTLPPDS60.....37
BRTAGDD54.....37	BRTBAR4P3066LR.....16	BRTBAR6PA3072LR.....17	BRTEBFK.....32	BRTEB84.....25	BRTLPPDS66.....37



BRTL PDS72.....37	BRTS1P2463L.....9	BRTS2P2448L.....10	BRTS4P2466L.....10	BRTSTS0863.....44	BRTWS3066.....27
BRTL PDS78.....37	BRTS1P2463LR.....13	BRTS2P2448LR.....14	BRTS4P2466LR.....15	BRTSTS1324.....44	BRTWS3072.....27
BRTL PDS84.....37	BRTS1P2466C.....9	BRTS2P2454L.....10	BRTS4P2472L.....10	BRTSTS1330.....44	BRTWS3078.....27
BRTL PED24.....38	BRTS1P2466CR.....14	BRTS2P2454LR.....14	BRTS4P2472LR.....15	BRTSTS1351.....44	BRTWS3084.....27
BRTL PED30.....38	BRTS1P2466L.....9	BRTS2P2460L.....10	BRTS4P2478L.....10	BRTSTS1363.....44	BRTWSA2442.....27
BRTL PED51.....38	BRTS1P2466LR.....13	BRTS2P2460LR.....14	BRTS4P2478LR.....15	BRTSTS1624.....6, 44	BRTWSA2448.....27
BRTL PED63.....6, 38	BRTS1P2472C.....9	BRTS2P2466L.....10	BRTS4P2484L.....10	BRTSTS1630.....44	BRTWSA2454.....27
BRTL PPD24.....38	BRTS1P2472CR.....14	BRTS2P2466LR.....14	BRTS4P2484LR.....15	BRTSTS1651.....8, 44	BRTWSA2460.....27
BRTL PPD30.....38	BRTS1P2472L.....9	BRTS2P2472L.....10	BRTS4P3048L.....10	BRTSTS1663.....44	BRTWSA2466.....27
BRTL SC.....23	BRTS1P2472LR.....13	BRTS2P2472LR.....14	BRTS4P3048LR.....15	BRTT5024L.....46	BRTWSA2472.....7, 27
BRTLVR.....4, 18, 23	BRTS1P2478C.....9	BRTS2P2478L.....10	BRTS4P3054L.....10	BRTT5024R.....46	BRTWSA2478.....27
BRTLVS.....4, 22	BRTS1P2478CR.....14	BRTS2P2478LR.....14	BRTS4P3054LR.....15	BRTT5030L.....46	BRTWSA2484.....27
BRTMPS36.....39	BRTS1P2478L.....9	BRTS2P2484L.....10	BRTS4P3060L.....10	BRTT5030R.....46	BRTWSA3042.....27
BRTMPS42.....39	BRTS1P2478LR.....13	BRTS2P2484LR.....14	BRTS4P3060LR.....15	BRTTB36.....26	BRTWSA3048.....27
BRTMPS48.....39	BRTS1P2484C.....9	BRTS2P3048L.....10	BRTS4P3066L.....10	BRTTB42.....26	BRTWSA3054.....27
BRTMPS54.....39	BRTS1P2484CR.....14	BRTS2P3048LR.....14	BRTS4P3066LR.....15	BRTTB48.....26	BRTWSA3060.....27
BRTMPS60.....39	BRTS1P2484L.....9	BRTS2P3054L.....10	BRTS4P3072L.....10	BRTTB54.....26	BRTWSA3066.....27
BRTMPS66.....39	BRTS1P2484LR.....13	BRTS2P3054LR.....14	BRTS4P3072LR.....15	BRTTB60.....6, 26	BRTWSA3072.....27
BRTMPS72.....6, 39	BRTS1P3036C.....9	BRTS2P3060L.....10	BRTS4P3078L.....10	BRTTB66.....26	BRTWSA3078.....27
BRTMPS78.....39	BRTS1P3036CR.....14	BRTS2P3060LR.....14	BRTS4P3078LR.....15	BRTTB72.....26	BRTWSA3084.....27
BRTMPS84.....39	BRTS1P3036L.....9	BRTS2P3066L.....10	BRTS4P3084L.....10	BRTTB78.....26	BVATH01.....40
BRTMT5151.....28	BRTS1P3036LR.....13	BRTS2P3066LR.....14	BRTS4P3084LR.....15	BRTTB84.....26	
BRTMTPR2448.....29	BRTS1P3042C.....9	BRTS2P3072L.....10	BRTSA21.....7, 26	BRTTEGF.....39	
BRTMTR42.....28	BRTS1P3042CR.....14	BRTS2P3072LR.....14	BRTSA25.....7, 8, 26	BRTTES24.....7, 44	
BRTPDMA.....35	BRTS1P3042L.....9	BRTS2P3078L.....10	BRTSB24.....25	BRTTES30.....44	
BRTPDMAJ.....35	BRTS1P3042LR.....13	BRTS2P3078LR.....14	BRTSB36.....25	BRTTES51.....44	
BRTPDS.....34	BRTS1P3048C.....9	BRTS2P3084L.....10	BRTSB42.....25	BRTTES63.....6, 44	
BRTPEG24.....39	BRTS1P3048CR.....14	BRTS2P3084LR.....14	BRTSB48.....25	BRTTOTO.....42	
BRTPEG30.....39	BRTS1P3048L.....9	BRTS3P2448L.....10	BRTSB51.....25	BRTTW5024L.....7, 46	
BRTPEG51.....8, 39	BRTS1P3048LR.....13	BRTS3P2448LR.....15	BRTSB54.....25	BRTTW5024R.....7, 46	
BRTPEG63.....39	BRTS1P3051C.....9	BRTS3P2454L.....10	BRTSB60.....25	BRTTW5030L.....46	
BRTPO2448CR.....18	BRTS1P3051CR.....14	BRTS3P2454LR.....15	BRTSB63.....25	BRTTW5030R.....46	
BRTPR2448C.....18	BRTS1P3051L.....9	BRTS3P2460L.....10	BRTSB66.....25	BRTVCM2118.....35	
BRTRA2C.....20	BRTS1P3051LR.....13	BRTS3P2460LR.....15	BRTSB72.....25	BRTVCM2124.....35	
BRTRA2L.....20	BRTS1P3054C.....9	BRTS3P2466L.....10	BRTSB78.....25	BRTVCM2518.....7, 8, 35	
BRTL.....23	BRTS1P3054CR.....14	BRTS3P2466LR.....15	BRTSB84.....25	BRTVCM2524.....35	
BRTS1P2436C.....9	BRTS1P3054L.....9	BRTS3P2472L.....10	BRTSDS48.....8, 46	BRTWAC120424224.6, 28	
BRTS1P2436CR.....14	BRTS1P3054LR.....13	BRTS3P2472LR.....15	BRTSL.....22	BRTWAC120424230.....28	
BRTS1P2436L.....9	BRTS1P3060C.....9	BRTS3P2478L.....10	BRTSL24C.....21	BRTWAC120A424224.....28	
BRTS1P2436LR.....13	BRTS1P3060CR.....14	BRTS3P2478LR.....15	BRTSL24C42.....21	BRTWAC120A424230.....28	
BRTS1P2442C.....9	BRTS1P3060L.....9	BRTS3P2484L.....10	BRTSL24L.....6-8, 21	BRTWBE2451R.....28	
BRTS1P2442CR.....14	BRTS1P3060LR.....13	BRTS3P2484LR.....15	BRTSL24L42.....21	BRTWBE2463R.....28	
BRTS1P2442L.....9	BRTS1P3063C.....9	BRTS3P3048L.....10	BRTSL30C.....21	BRTWBE3051R.....28	
BRTS1P2442LR.....13	BRTS1P3063CR.....14	BRTS3P3048LR.....15	BRTSL30C42.....21	BRTWBE3063R.....28	
BRTS1P2448C.....9	BRTS1P3063L.....9	BRTS3P3054L.....10	BRTSL30L.....21	BRTWS2436.....27	
BRTS1P2448CR.....14	BRTS1P3063LR.....13	BRTS3P3054LR.....15	BRTSL30L42.....21	BRTWS2442.....27	
BRTS1P2448L.....9	BRTS1P3066C.....9	BRTS3P3060L.....10	BRTSLDT72C.....8, 18	BRTWS2448.....8, 27	
BRTS1P2448LR.....13	BRTS1P3066CR.....14	BRTS3P3060LR.....15	BRTSLDT72CR.....19	BRTWS2451.....27	
BRTS1P2451C.....9	BRTS1P3066L.....9	BRTS3P3066L.....10	BRTSQ42C.....20	BRTWS2454.....27	
BRTS1P2451CR.....14	BRTS1P3066LR.....13	BRTS3P3066LR.....15	BRTSQ42L.....20	BRTWS2460.....6, 27	
BRTS1P2451L.....9	BRTS1P3072C.....9	BRTS3P3072L.....10	BRTSTB36.....26	BRTWS2463.....27	
BRTS1P2451LR.....13	BRTS1P3072CR.....14	BRTS3P3072LR.....15	BRTSTB42.....26	BRTWS2466.....27	
BRTS1P2454C.....9	BRTS1P3072L.....6, 9	BRTS3P3078L.....10	BRTSTB48.....26	BRTWS2472.....7, 8, 27	
BRTS1P2454CR.....14	BRTS1P3072LR.....13	BRTS3P3078LR.....15	BRTSTB54.....26	BRTWS2478.....27	
BRTS1P2454L.....9	BRTS1P3078C.....9	BRTS3P3084L.....10	BRTSTB60.....26	BRTWS2484.....27	
BRTS1P2454LR.....13	BRTS1P3078CR.....14	BRTS3P3084LR.....15	BRTSTB66.....26	BRTWS3036.....27	
BRTS1P2460C.....9	BRTS1P3078L.....9	BRTS4P2448L.....10	BRTSTB72.....7, 8, 26	BRTWS3042.....27	
BRTS1P2460CR.....14	BRTS1P3078LR.....13	BRTS4P2448LR.....15	BRTSTB78.....26	BRTWS3048.....27	
BRTS1P2460L.....9	BRTS1P3084C.....9	BRTS4P2454L.....10	BRTSTB84.....26	BRTWS3051.....27	
BRTS1P2460LR.....13	BRTS1P3084CR.....14	BRTS4P2454LR.....15	BRTSTS0824.....44	BRTWS3054.....27	
BRTS1P2463C.....9	BRTS1P3084L.....9	BRTS4P2460L.....10	BRTSTS0830.....44	BRTWS3060.....27	
BRTS1P2463CR.....14	BRTS1P3084LR.....13	BRTS4P2460LR.....15	BRTSTS0851.....44	BRTWS3063.....27	



VALUE IS ALWAYS IN STYLE™

SHOWROOMS + DISTRIBUTION CENTERS THROUGHOUT THE UNITED STATES

Global US Headquarters
17 West Stow Road
Marlton, NJ 08053
Tel: (856) 596-3390
Tel: (800) 220-1900
Fax: (856) 596-5684

Troy Hill Corporate Center
7030 Troy Hill Drive
Elkridge, MD 21075
Tel: (301) 362-9400
Tel: (800) 863-7300
Fax: (301) 362-9444

10351 Windhorst Road
Tampa, FL 33619
Tel: (813) 621-6272
Tel: (877) 707-3966
Fax: (813) 621-7958

5 Document Drive
St. Louis, MO 63114
Tel: (314) 432-4463
Fax: (314) 432-4471

2000 Freeway Boulevard
Brooklyn Center, MN 55430
Tel: (763) 560-8196
Tel: (800) 829-2153
Fax: (763) 560-2098

16401 East 33rd Drive, Suite 50
Aurora, CO 80011
Tel: (303) 340-1617
Tel: (800) 275-8655
Fax: (303) 340-1657

119 Greentree Road
Marlton, NJ 08053
Tel: (856) 596-3390
Tel: (800) 220-1900
Fax: (856) 596-4472

1130 Connecticut Avenue
Washington, DC 20036
Tel: (202) 659-0230
Fax: (202) 659-0306

560 Sawgrass Corporate Parkway
Sunrise, FL 33325
Tel: (954) 846-8888
Tel: (800) 331-0529
Fax: (954) 846-8110

11617 West 81st Street
Lenexa, KS 66214
Tel: (913) 310-9963
Tel: (800) 796-0770
Fax: (913) 310-9976

901 South Labarre Road,
Suite 201
Metairie, LA 70001
Tel: (504) 834-6228
Tel: (800) 275-0663
Fax: (504) 835-9638

4675 East Cotton Center Boulevard
Suite 165
Phoenix, AZ 85040
Tel: (602) 426-0666
Fax: (602) 426-1148

One Harbor Street, Suite 104
Boston, MA 02210
Tel: (617) 406-5435
Tel: (800) 876-8980
Fax: (617) 406-5438

Harris Ridge Business Center
6135 Lakeview Road - Suite 350
Charlotte, NC 28269
Tel: (704) 494-4866
Fax: (704) 494-4889

Las Olas City Center
401 East Las Olas Boulevard,
Suite 230
Ft. Lauderdale, FL 33301
Tel: (954) 763-2684
Fax: (954) 763-6870

The Merchandise Mart
10th Floor, Suite 1035
Chicago, IL 60654
Tel: (312) 755-0843
Fax: (312) 755-0837

2025 West Beltline Road, #100
Carrollton, TX 75006
Tel: (972) 236-1366
Tel: (800) 929-2936
Fax: (972) 236-1372

12320 Bloomfield Avenue,
Unit A
Santa Fe Springs, CA 90670
Tel: (562) 484-9686
Tel: (800) 640-0301
Fax: (562) 484-9685

19 Connector Road, Unit 1
Andover, MA 01810
Tel: (978) 470-8463
Tel: (800) 876-8980
Fax: (978) 470-8920

The Millennium Building
10 10th Street, Suite 150
Atlanta, GA 30309
Tel: (404) 879-0998
Fax: (404) 879-9995

380 Leetsdale Industrial Drive
Leetsdale, PA 15056
Tel: (724) 385-1200
Tel: (800) 942-9999
Fax: (724) 385-1207

1879 Internationale Boulevard
Glendale Heights, IL 60139
Tel: (630) 681-2818
Tel: (800) 866-6497
Fax: (630) 681-1631

7865 Northcourt Road,
Building D, Suite 200
Houston, TX 77040
Tel: (713) 695-5777
Tel: (800) 935-6468
Fax: (713) 695-5778

44091 Nobel Drive
Fremont, CA 94538
Tel: (510) 897-4150
Tel: (888) 418-4800
Fax: (510) 897-4156

386 Park Avenue South
New York, NY 10016
Tel: (212) 545-9900
Tel: (888) 315-1301
Fax: (212) 545-5826

2124 Evergreen Boulevard
Duluth, GA 30096
Tel: (678) 602-4130
Tel: (800) 220-7328
Fax: (678) 602-4136

8712 LeSaint Drive
Fairfield, OH 45014
Tel: (513) 777-0009
Tel: (800) 552-3375
Fax: (513) 777-5863

25925 Telegraph Road
Suite 145
Southfield, MI 48034
Tel: (248) 357-7211
Fax: (248) 357-7241

6950 Alamo Downs Parkway,
Suite 100
San Antonio, TX 78238
Tel: (210) 684-8450
Tel: (800) 683-4000
Fax: (210) 684-3700

Oakesdale Commerce Center
820 Southwest 34th Street
Building W7, Suite A
Renton, WA 98057
Tel: (425) 291-9282
Tel: (888) 218-2600
Fax: (425) 291-9267



PROUD TO BE AWARDED
OFDA MANUFACTURER OF THE YEAR
2007, 2008, 2009, 2010, 2011 AND 2012



thinkglobal™

www.globaltotaloffice.com