

PART DESCRIPTION

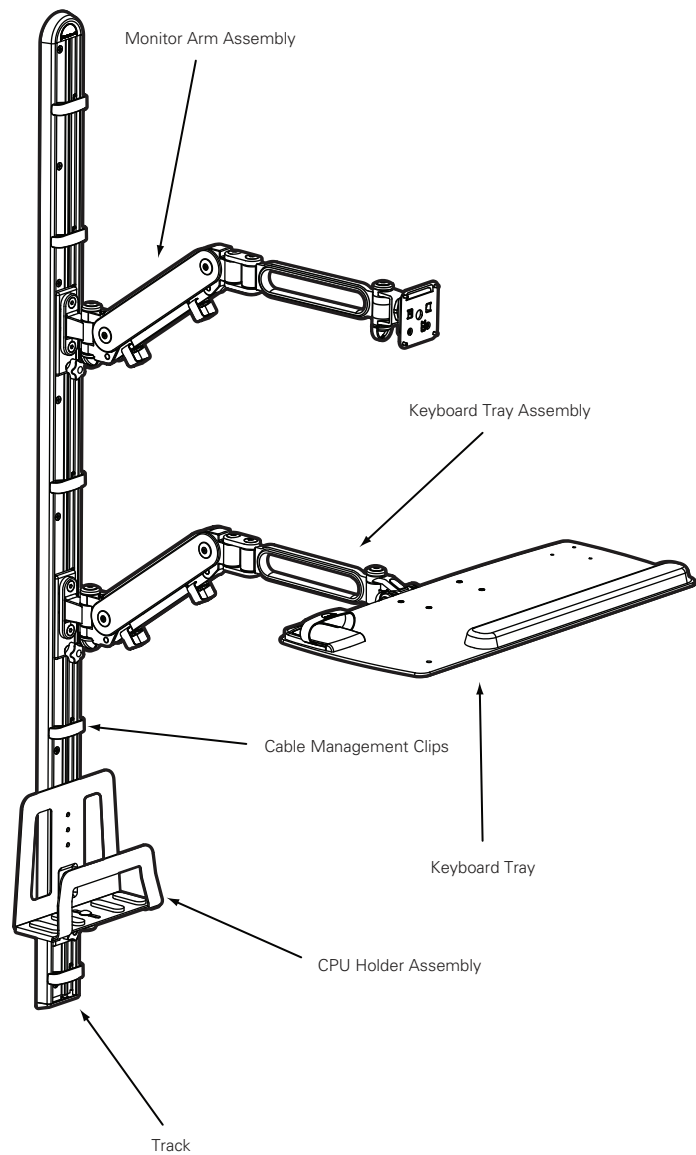

V5 INSTALLATION HARDWARE

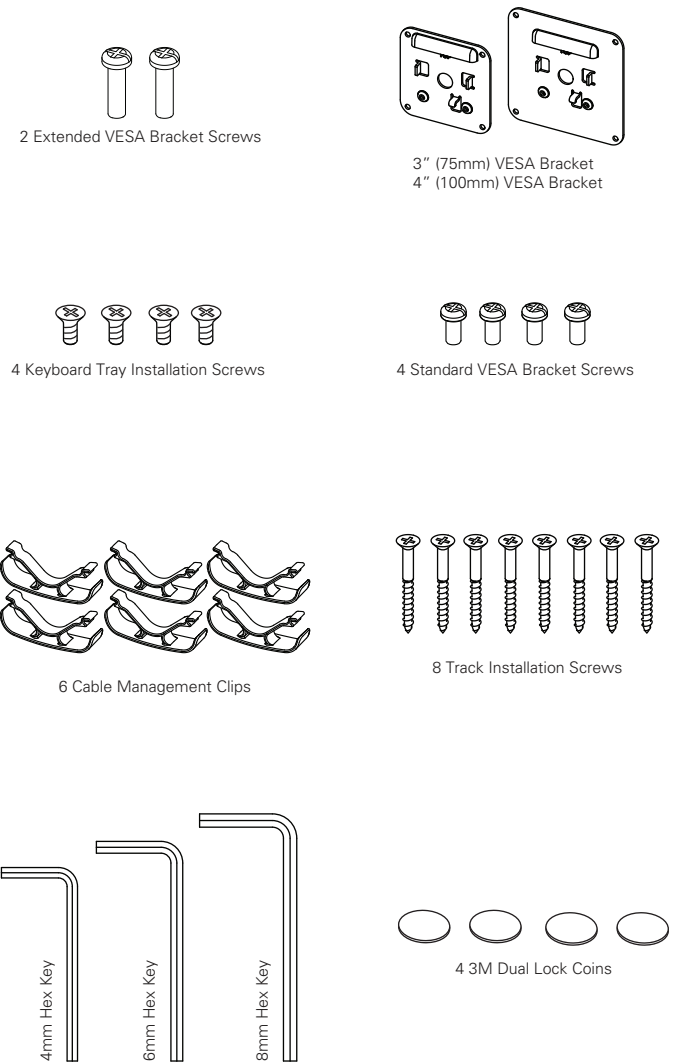

**ADDITIONAL HARDWARE REQUIRED:**  
Electric drill with 5/32" (4mm) drill bit

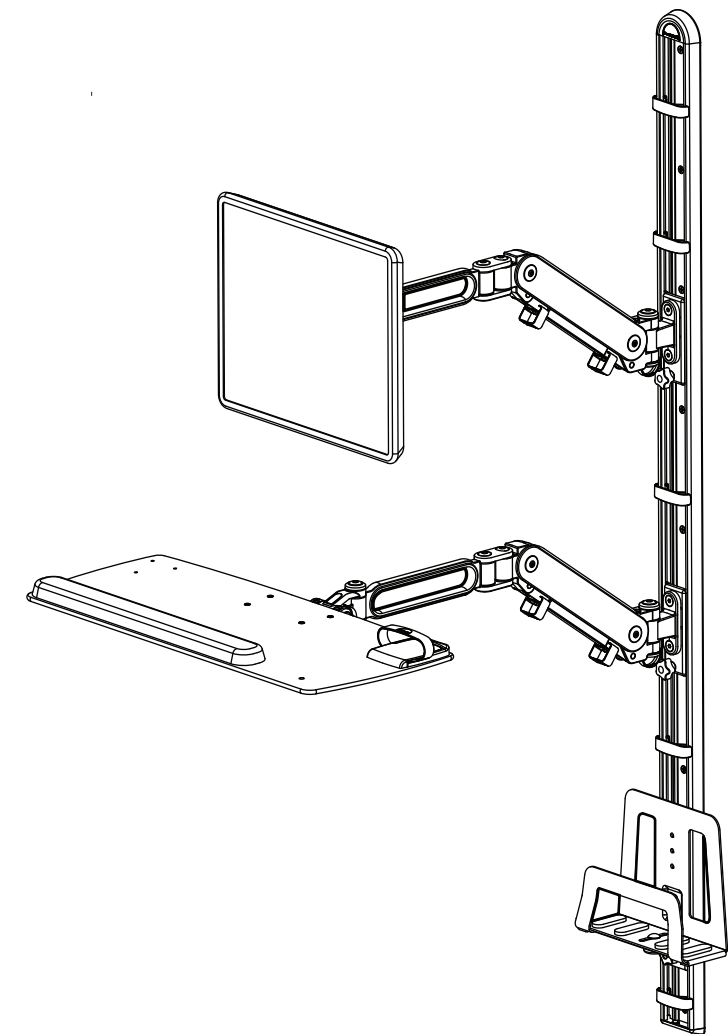

# V5 Installation Instructions

## STEP 1: MOUNT TRACK TO WALL

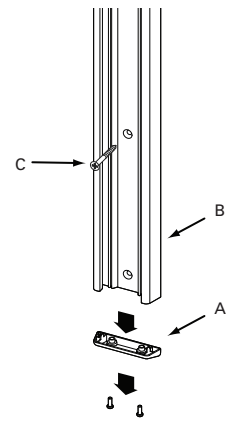

- Remove Bottom Plastic Cap (A) from Track (B) by removing the two Philips-head screws.
- Position Track against the wall at least 12" (30.5cm) from the floor. Use a level to ensure Track is perfectly plumb. Be sure at least one column of screw holes is aligned with a stud or other structural material.

*Note: Track can be mounted directly to a wood, metal, concrete or other structural wall surface. However, sheetrock installations require mounting to a wood or metal stud behind the sheetrock.*

- Mark hole positions.
- Drill mounting holes with a 5/32" (4mm) drill bit.
- Fasten Track to the wall using 8 Track Installation Screws (C). Be sure to tighten fully so the screw heads do not protrude.

*Note: Enclosed Track Installation Screws are recommended for use with wood studs or other structural wood material. For installation into metal studs or concrete, use screws specifically designed for those materials.*

12 in  
30.5cm

## STEP 2: INSTALL MONITOR ARM TO TRACK

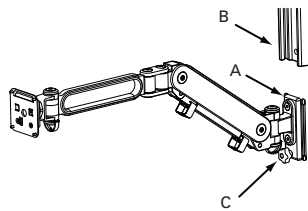

- Insert Sliding Bracket (A) into the bottom of Track (B) and position at desired height.
- Turn Locking Knob (C) clockwise to lock Sliding Bracket in place.

*Note: Actual Monitor Arm configuration may differ from what is pictured here.*

## STEP 3: ATTACH MONITOR TO MONITOR ARM

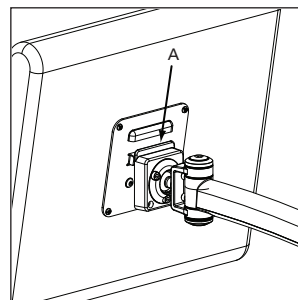

- Place the correct-size VESA Bracket on the back of Monitor and attach using 4 Standard VESA Bracket Screws.
- Slide VESA Bracket over the lip of Ball Joint (A). Insert 2 Extended VESA Bracket Screws into the holes in the back of Ball Joint and fasten.

## STEP 4: INSTALL KEYBOARD ARM TO TRACK

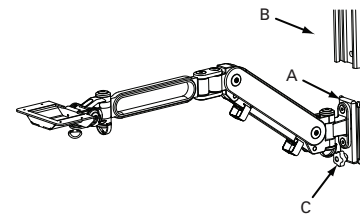

- Insert Sliding Bracket (A) into the bottom of Track (B) and position at desired height.
- Turn Locking Knob (C) clockwise to lock Sliding Bracket in place.

*Note: Actual Keyboard Arm configuration may differ from what is pictured here.*

## STEP 5: ATTACH KEYBOARD TRAY TO KEYBOARD ARM

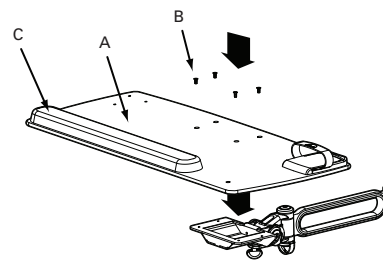

- Place Keyboard Tray (A) on Support Bracket and align holes.
- Fasten Keyboard Tray to Keyboard Arm using 4 Keyboard Tray Installation Screws (B).
- Snap Palm Rest (C) into the holes on Keyboard Tray.

## STEP 6: INSTALL CPU HOLDER TO TRACK

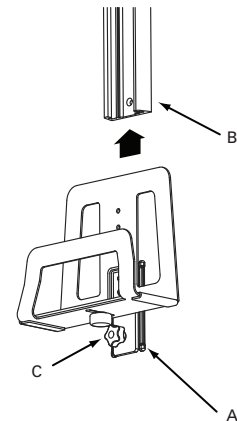

- Insert Sliding Bracket (A) into the bottom of Track (B) and position at desired height.
- Turn Locking Knob (C) clockwise to lock Sliding Bracket in place.

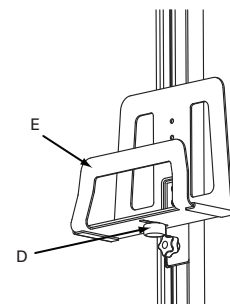

- Loosen other Locking Knob (D) and place CPU into CPU Holder. Slide Front Bracket (E) inward so it sits tightly against CPU. Tighten Locking Knob to secure.

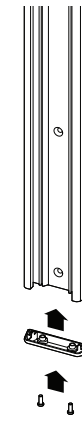

- Replace Bottom Plastic Cap on Track and fasten using the two Philips-head screws that originally secured it.

*Note: To install CPU Holder directly to a wall, remove Sliding Bracket by removing the 2 CPU Holder screws. Attach CPU Holder to a wall using screws recommended for that wall construction (not included).*

## CABLE MANAGEMENT

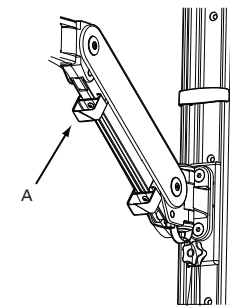

- Unscrew Cable Management Clips (A) from Monitor Arm. Route Monitor Cables through Cable Management Clips and replace screws.
- Repeat the above step to route Keyboard Cables.

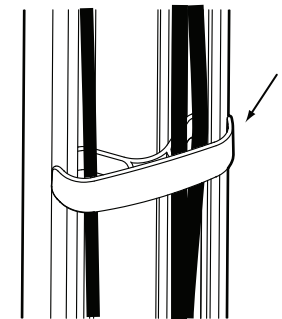

- Route Monitor and Keyboard Cables down through the middle of Track. Position Track Cable Clips (B) vertically within the middle of Track and turn 90 degrees. Be sure to trap the cables between Track Cable Clips and Track.

## ADJUSTING MONITOR/KEYBOARD ARM TENSION

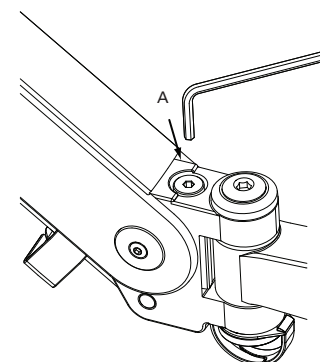

- Turn Tension Screw (A) using 4mm Hex Key. Turn clockwise to decrease tension for lighter monitors or counterclockwise to increase tension for heavier monitors.

## FRICTION ADJUSTMENT

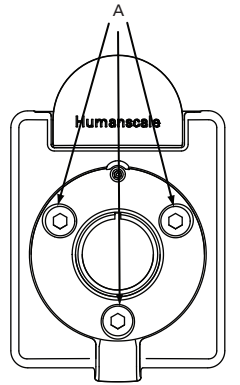

- After prolonged use, your monitor's Ball Joint Swivel/Tilt Mechanism may require increased friction. To increase friction, tighten the 3 Ball Joint Friction Screws (A) using 4mm Hex Key.

## ATTACH KEYBOARD TO KEYBOARD TRAY

- Place 4 3M Dual Lock Coins on the underside of Keyboard.
- Once attached, remove the film from the exposed sides of Dual Lock Coins and attach to Keyboard Tray.

