

Notes:

Job:

Type:

POLES

5" STRAIGHT ROUND ALUMINUM (CAST BASE)

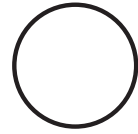

GENERAL DESCRIPTION: The Gardco/Emco Lighting RA5 straight aluminum pole consists of a one-piece 5" round extruded aluminum lighting standard mounted to a cast aluminum base. The poles are finished with either Architectural Class 1 anodizing or electrostatically applied TGIC polyester powdercoat. All poles include anchor bolts, full base cover, hand hole, ground lug and top cap.

ORDERING

| PREFIX | BASE TYPE | HEIGHT | DRILLING | FINISH | OPTIONS |
|----------------------|----------------------|----------------------|----------------------|----------------------|----------------------|
| <input type="text"/> | <input type="text"/> | <input type="text"/> | <input type="text"/> | <input type="text"/> | <input type="text"/> |

Enter the order code into the appropriate box above. Note: Gardco reserves the right to refuse a configuration. Not all combinations and configurations are valid. Refer to notes below for exclusions and limitations. For questions or concerns, please consult the factory.

PREFIX

RA5

BASE TYPE

CB Fixed Cast Base

HEIGHT

15' L,M,H¹18' L,M,H¹20' L,M,H¹

DRILLING

D1 1 Way

D2 2 Way

D3 3 Way

D4 4 Way

T2 2 3/8" OD Tenon

T4 4" OD Tenon

Hinged Bases are available for this pole. Please refer to Hinged Base Pole sheet 79415-8 for specifications and dimensions.

1. Refers to relative strength based on wind load factors.
L=Light; M = Medium; H = Heavy.

FINISH

BRA Bronze Anodized

BLA Black Anodized

NA Natural Anodized

BRP Bronze Paint

BLP Black Paint

WP White Paint

NP Natural Aluminum Paint

OC

Optional Color Paint
Specify RAL designation as shown ex: OC-RAL7024.

SC

Special Color Paint
Specify. Must supply color chip.

OPTIONS

DR Duplex Receptacle

GFCI Ground Fault Receptacle

VDA Vibration Dampener

Nipples and Couplings

NL³ Nipple - External thread.CL³ Coupling - Internal thread.

3. Indicate size (1/2", 3/4", 1", 1 1/4", or 1 1/2")

Side Mount Bullhorn Brackets

A15BH⁴ SingleA215BH⁴ 2-Tenon

4. Add "-19" for 1.9" OD or "-24" for 2.4" OD.

Refer to Aluminum Pole Accessories (79415-25) for additional Floodlight and Bullhorn Brackets. For DR, GFCI, NL, CL options and Side Mount Bullhorn Brackets, indicate height above base and orientation to handhole. See Pole Orientation Information (79415-12.)

POLE DATA

| CATALOG NUMBER | POLE SIZE | | MAXIMUM LUMINAIRE LOADING* | | | ANCHOR BOLT DATA** | | |
|----------------|---------------|---------------|----------------------------|-----------------------------|----------------------------|----------------------------|----------------------|--------------------|
| | PREFIX-HEIGHT | ACTUAL HEIGHT | WALL THICKNESS (inches) | 100 MPH EPA-FT ² | 90 MPH EPA-FT ² | 80 MPH EPA-FT ² | BOLT CIRCLE (inches) | BOLT SIZE (inches) |
| RA5-CB-15L | 15' | .125 | 4.0 | 5.2 | 6.9 | 7.5-9.5 | 3/4 x 17 x 3 | 3.25 |
| RA5-CB-15M | 15' | .156 | 5.6 | 7.2 | 9.4 | 7.5-9.5 | 3/4 x 17 x 3 | 3.25 |
| RA5-CB-15H | 15' | .188 | 7.2 | 9.2 | 11.9 | 7.5-9.5 | 3/4 x 17 x 3 | 3.25 |
| RA5-CB-18L | 18' | .125 | 2.8 | 3.6 | 5.1 | 7.5-9.5 | 3/4 x 17 x 3 | 3.25 |
| RA5-CB-18M | 18' | .156 | 4.1 | 5.4 | 7.2 | 7.5-9.5 | 3/4 x 17 x 3 | 3.25 |
| RA5-CB-18H | 18' | .188 | 5.5 | 8.0 | 9.4 | 7.5-9.5 | 3/4 x 17 x 3 | 3.25 |
| RA5-CB-20L | 20' | .125 | 1.8 | 2.5 | 3.5 | 7.5-9.5 | 3/4 x 17 x 3 | 3.25 |
| RA5-CB-20M | 20' | .156 | 3.1 | 4.0 | 5.5 | 7.5-9.5 | 3/4 x 17 x 3 | 3.25 |
| RA5-CB-20H | 20' | .188 | 4.2 | 5.6 | 7.5 | 7.5-9.5 | 3/4 x 17 x 3 | 3.25 |

*Warning: Additional wind loading, in terms of EPA, from banners, cameras, floodlights and other accessories attached to the pole, must be added to the luminaire(s) EPA before selecting the pole with the appropriate wind load capability.

**Factory supplied template MUST be used when setting anchor bolts. Gardco/Emco Lighting will not honor any claim for incorrect anchorage placement resulting from failure to use factory supplied templates.

Gardco Lighting/EMCO Lighting reserves the right to change materials or modify the design of its product without notification as part of the company's continuing product improvement program.

© Copyright Gardco Lighting 2001-2007. All Rights Reserved. International Copyright Secured.

A Genlyte Company

1611 Clovis Barker Road
San Marcos, TX 78666
800/227-0758
512/753-1000
Fax: 512/753-7855
www.sitelighting.com



79415-36/1007

POLES 5" STRAIGHT ROUND ALUMINUM (CAST BASE)

SPECIFICATIONS

All aluminum alloys shall comply with metallurgical and mechanical properties set forth in the Aluminum Association Standards.

POLE SHAFT: The shaft shall be extruded from all new seamless 6063 alloy aluminum and shall be heat treated to produce a T6 temper. The shaft shall be polished with fine grain aluminum oxide cloths, resulting in a high quality circumferential satin brushed finish. After finishing, each pole shall be fully tire-wrapped with neutral PH krinkle/kraft paper for protection in shipment.

ANCHOR BASE: The anchor base is cast from A356 alloy aluminum. The shaft shall be inserted into the anchor base casting. The anchor base casting and shaft shall be joined by a continuous circumferential weld at the inside bottom of the anchor base. The completed assembly shall be heat treated to a T6 condition. A full base cover shall be included with each anchor base.

ANCHOR BOLTS: Anchor bolts are fabricated from a commercial quality hot rolled carbon steel bar that meets or exceeds a minimum guaranteed yield strength of 50,000 psi. Bolts have an "L" bend on one end and threaded on the opposite end. Anchor bolts are completely hot dipped galvanized. Four (4) properly sized bolts, each furnished with two (2) regular hex nuts and two (2) flat washers, are provided per pole, unless otherwise specified.

HANDHOLE: All poles shall include a peripherally reinforced flush covered handhole centered 18" above the bottom of the pole. The opening shall measure 3" X 5".

POLE TOP CAP: Each pole assembly is provided with a removable composite friction-fit pole top cap.

FINISH: Poles are available with bronze, natural or black Aluminum Association Architectural Class 1 anodized finish. Electrostatically applied, thermally cured TGIC polyester powdercoat finish or liquid polyurethane is also available.

DESIGN: The poles as charted are designed to withstand dead loads and predicted dynamic loads developed by variable wind speeds with an additional 30% gust factor under the following conditions:

The charted weights include luminaire(s) and/or mounting bracket(s).

The wind velocities are based on 10 mph increments from 80 mph through 100 mph. Poles to be located in areas of known abnormal conditions may require special consideration. For example: coastal areas, airports and areas of special winds.

Poles are designed for ground mounted applications. Poles mounted on structures (such as buildings and bridges) may also necessitate special consideration requiring Gardco/Emco Lighting's recommendation.

Height correction factors and drag coefficients are applied to the entire structure. An appropriate safety factor is maintained based on the minimum yield strength of the material incorporated in the pole.

WARNING: This design information is intended as a general guideline only. The customer is solely responsible for proper selection of pole, luminaire, accessory and foundation under the given site conditions and intended usage. The addition of any items to the pole, in addition to the luminaire, will dramatically impact the EPA load on that pole. It is strongly recommended that a qualified professional be consulted to analyze the loads given the user's specific needs to ensure proper selection of the pole, luminaire, accessories, and foundation. Gardco/Emco Lighting and Genlyte Group assume no responsibility for such proper analysis or product selections. **Failure to insure proper site analysis, pole selection, loads and installation can result in pole failure, leading to serious injury or property damage.**

GENERAL INFORMATION: Mounting height is the vertical distance from the base of the lighting pole to the center of the luminaire arm at the point of luminaire attachment.

Twin arms as charted are oriented at 180° with respect to each other. For applications of two (2) arms at 90° or other multiple arm applications, consult the factory.

DIMENSIONS

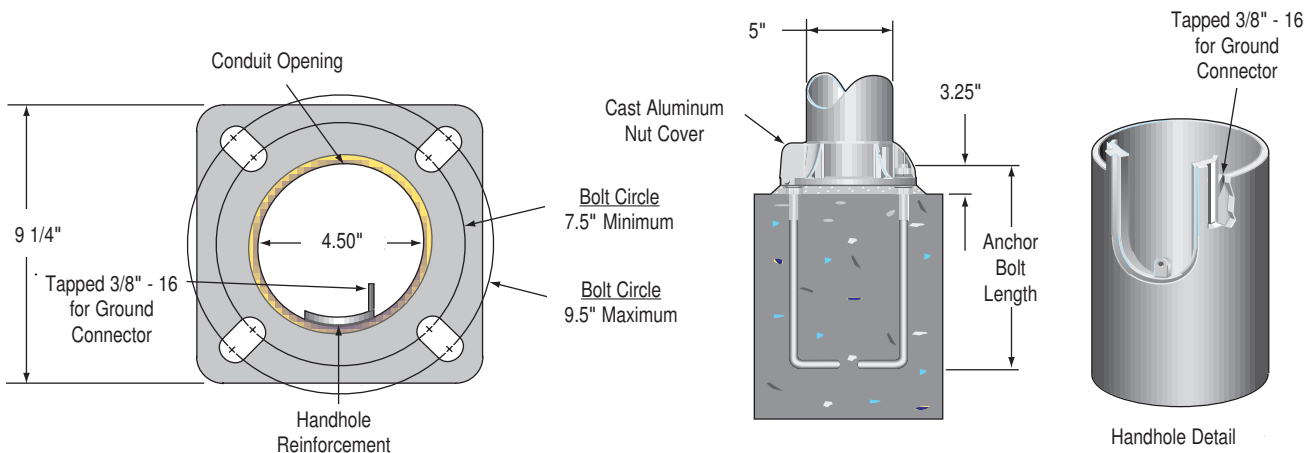

NOTE: Factory supplied template MUST be used when setting anchor bolts. Gardco Lighting will not honor any claim for incorrect anchorage placement from failure to use factory supplied templates.

Gardco Lighting/EMCO Lighting reserves the right to change materials or modify the design of its product without notification as part of the company's continuing product improvement program.

© Copyright Gardco Lighting 2001-2005. All Rights Reserved. International Copyright Secured.

A Genlyte Company

1611 Clovis Barker Road
San Marcos, TX 78666
800/227-0758
512/753-1000
Fax: 512/753-7855
www.sitelighting.com

