

Notes:

Job:

Type:

# POLES

## 6" STRAIGHT SQUARE ALUMINUM (TENON BASE)



**GENERAL DESCRIPTION:** The Gardco/Emco Lighting SSA6 straight aluminum pole consists of a one-piece 6" square extruded aluminum lighting standard mounted to a structural quality carbon galvanized steel base tenon. This construction offers the corrosion resistance and flexibility of aluminum with the strength and integrity of steel. The poles are finished with either Architectural Class 1 anodizing or electrostatically applied TGIC polyester powdercoat. All poles include anchor bolts, full base cover, hand hole, ground lug and top cap.

### ORDERING

PREFIX	BASE TYPE	HEIGHT	DRILLING	FINISH	OPTIONS
<input type="text"/>	<input type="text"/>	<input type="text"/>	<input type="text"/>	<input type="text"/>	<input type="text"/>

Enter the order code into the appropriate box above. Note: Gardco reserves the right to refuse a configuration. Not all combinations and configurations are valid. Refer to notes below for exclusions and limitations. For questions or concerns, please consult the factory.

### PREFIX

SSA6

### BASE TYPE

STB *Fixed Steel Tenon Base*

### HEIGHT

15'

18'

20'

25'

28'

30' L,M,H<sup>1</sup>33' L,M,H<sup>1</sup>

1. Refers to steel base tenon size (length and thickness) based on wind load factors.

L = Light;

M = Medium;

H = Heavy.

### DRILLING

D1 1 Way

D2 2 Way

D3 3 Way

D4 4 Way

T2 2 3/8" OD Tenon

T4 4" OD Tenon

### FINISH

BRA *Bronze Anodized*BLA *Black Anodized*NA *Natural Anodized*BRP *Bronze Paint*BLP *Black Paint*WP *White Paint*NP *Natural Aluminum Paint*

OC

*Optional Color Paint*  
Specify RAL designation as shown ex: OC-RAL7024.

SC

*Special Color Paint*  
Specify. Must supply color chip.

### OPTIONS

DR<sup>3</sup> *Duplex Receptacle*GFCI<sup>3</sup> *Ground Fault Receptacle*VDA *Vibration Dampener*

3. Replaces handhole, located 20" above base.

#### Nipples and Couplings

NL<sup>5</sup> *Nipple - External thread.*CL<sup>5</sup> *Coupling - Internal thread.*

5. Indicate size (1/2", 3/4", 1", 1 1/4", or 1 1/2")

#### Side Mount Bullhorn Brackets

A15BH<sup>4</sup> *Single*A215BH<sup>4</sup> *2-Tenon*

4. Add "-19" for 1.9" OD or "-24" for 2.4" OD.

Refer to Aluminum Pole Accessories (79415-25) for additional Floodlight and Bullhorn Brackets. For Nipples, Couplings, and Side Mount Bullhorn Brackets, indicate height above base and orientation to handhole. See Pole Orientation Information (79415-12.)

### POLE DATA

CATALOG NUMBER	POLE SIZE	MAXIMUM LUMINAIRE LOADING*			ANCHOR BOLT DATA**				
		100 MPH EPA-FT <sup>2</sup>	90 MPH EPA-FT <sup>2</sup>	80 MPH EPA-FT <sup>2</sup>	BOLT CIRCLE (inches)	BOLT SIZE (inches)	MAX PROJ. (inches)		
SSA6-STB-15	14' 9"	3	.170	25.8	32.7	42.5	11.0	1 x 36 x 4.5	5.0
SSA6-STB-18	17' 9"	3	.170	18.3	23.8	31.5	11.0	1 x 36 x 4.5	5.0
SSA6-STB-20	19' 9"	3	.170	14.5	19.3	26.0	11.0	1 x 36 x 4.5	5.0
SSA6-STB-25	24' 9"	3	.170	7.3	10.9	15.9	11.0	1 x 36 x 4.5	5.0
SSA6-STB-28	27' 9"	3	.170	4.0	7.7	11.4	11.0	1 x 36 x 4.5	5.0
SSA6-STB-30L	29' 9"	3	.170	1.8	4.4	8.0	11.0	1 x 36 x 4.5	5.0
SSA6-STB-30M	29' 9"	6	.170	4.0	6.9	10.9	11.0	1 x 36 x 4.5	5.0
SSA6-STB-30H	29' 9"	9	.170	6.5	9.8	14.4	12.0	1.25 x 42 x 6	5.0
SSA6-STB-33L	32' 9"	3	.170	-	1.5	4.7	11.0	1 x 36 x 4.5	5.0
SSA6-STB-33M	32' 9"	6	.170	1.1	3.7	7.2	11.0	1 x 36 x 4.5	5.0
SSA6-STB-33H	32' 9"	9	.170	3.3	6.1	10.0	12.0	1.25 x 42 x 6	5.0

\*Warning: Additional wind loading, in terms of EPA, from banners, cameras, floodlights and other accessories attached to the pole, must be added to the luminaire(s) EPA before selecting the pole with the appropriate wind load capability.

\*\*Factory supplied template MUST be used when setting anchor bolts.

Gardco/Emco Lighting will not honor any claim for incorrect anchorage placement resulting from failure to use factory supplied templates.

Gardco Lighting/EMCO Lighting reserves the right to change materials or modify the design of its product without notification as part of the company's continuing product improvement program.

© Copyright Gardco Lighting 2001-2007. All Rights Reserved. International Copyright Secured.

A Genlyte Company

1611 Clovis Barker Road  
San Marcos, TX 78666  
800/227-0758  
512/753-1000  
Fax: 512/753-7855  
www.sitelighting.com



79415-4/1007

# POLES 6" STRAIGHT SQUARE ALUMINUM (TENON BASE)

## SPECIFICATIONS

**POLE SHAFT:** The pole shaft is a one-piece, 6" square, seamless 6000 series extruded aluminum tubing and is heat-treated to achieve a T6 temper with a guaranteed minimum yield strength of 31 KSI. Pole wall thickness is .170".

**BASE TENON ASSEMBLY:** The tenon anchor base assembly consists of structural quality carbon steel tubing with a minimum 46 KSI yield strength welded to a structural steel base with a guaranteed minimum yield strength of 50 KSI. The base plate telescopes the pole shaft and is circumferentially welded on both top and bottom. The entire assembly is hot-dipped galvanized. Four (4) mechanically galvanized fasteners secure the aluminum pole shaft to the base tenon assembly.

**ANCHOR BOLTS:** Anchor bolts are fabricated from a commercial quality hot rolled carbon steel bar that meets or exceeds a minimum guaranteed yield strength of 50,000 psi. Bolts have an "L" bend on one end and threaded on the opposite end. 1" anchor bolts are completely hot dipped galvanized. 1 1/4" anchor bolts are galvanized 12" on the threaded end. Four (4) properly sized bolts, each furnished with two (2) regular hex nuts and two (2) flat washers, are provided per pole, unless otherwise specified.

**BASE COVER:** A two-piece, fabricated aluminum cover completely conceals the entire base plate and anchorage. The base cover is secured to the base assembly with four (4) stainless steel fasteners.

**HANDHOLE:** The handhole has a nominal rectangular 3" X 5" inside opening in the pole shaft and tenon assembly. Included is an aluminum cover plate with attachment screws. The handhole is located 20" above the base and 180° clockwise with respect to the luminaire arm when viewed from the top of the pole for one arm. For two arms the handhole is located directly under one arm.

**POLE TOP CAP:** Each pole assembly is provided with a removable cast aluminum pole top cap. The pole top cap is secured with two (2) stainless steel allen head set screws.

**FINISH:** Poles are available with bronze, natural or black Aluminum Association Architectural Class 1 anodized finish. Electrostatically applied, thermally cured TGIC polyester powdercoat finish is also available.

**DESIGN:** The poles as charted are designed to withstand dead loads and predicted dynamic loads developed by variable wind speeds with an additional 30% gust factor under the following conditions:

The charted weights include luminaire(s) and/or mounting bracket(s).

The wind velocities are based on 10 mph increments from 80 mph through 100 mph. Poles to be located in areas of known abnormal conditions may require special consideration. For example: coastal areas, airports and areas of special winds.

Poles are designed for ground mounted applications. Poles mounted on structures (such as buildings and bridges) may also necessitate special consideration requiring Gardco/Emco Lighting's recommendation. Height correction factors and drag coefficients are applied to the entire structure. An appropriate safety factor is maintained based on the minimum yield strength of the material incorporated in the pole.

**WARNING:** This design information is intended as a general guideline only. The customer is solely responsible for proper selection of pole, luminaire, accessory and foundation under the given site conditions and intended usage. The addition of any items to the pole, in addition to the luminaire, will dramatically impact the EPA load on that pole. It is strongly recommended that a qualified professional be consulted to analyze the loads given the user's specific needs to ensure proper selection of the pole, luminaire, accessories, and foundation. Gardco/Emco Lighting and Genlyte Group assume no responsibility for such proper analysis or product selections. **Failure to insure proper site analysis, pole selection, loads and installation can result in pole failure, leading to serious injury or property damage.**

**GENERAL INFORMATION:** Mounting height is the vertical distance from the base of the lighting pole to the center of the luminaire arm at the point of luminaire attachment.

Twin arms as charted are oriented at 180° with respect to each other. For applications of two (2) arms at 90° or other multiple arm applications, consult the factory.

## DIMENSIONS

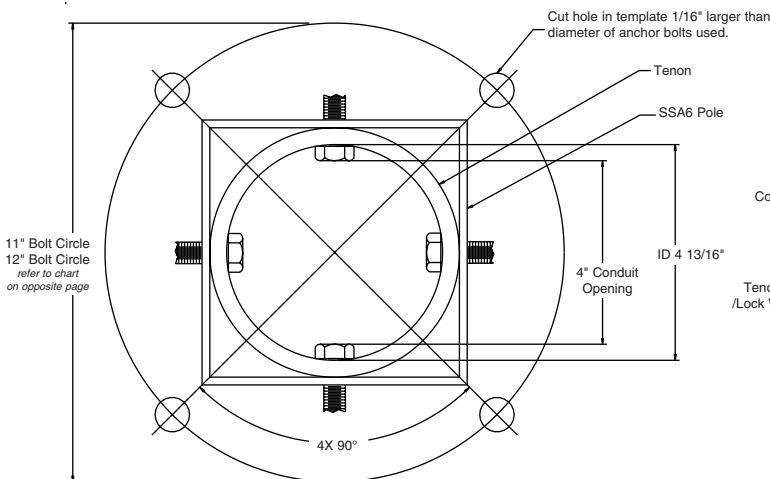

NOTE: Internal clearance of tenon/pole mounting bolts dictates allowable area for stub-ups.

**NOTE:** Factory supplied template **MUST** be used when setting anchor bolts. Gardco Lighting will not honor any claim for incorrect anchorage placement from failure to use factory supplied templates.

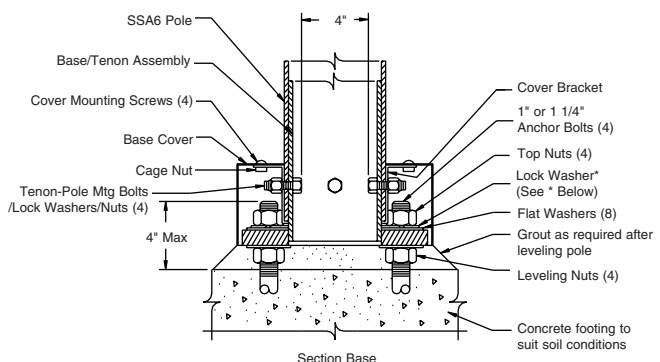

\*Anchor Bolt Lock Washers are not normally required and are not included in standard anchor bolt sets. They are available upon request at additional cost.

Gardco Lighting/EMCO Lighting reserves the right to change materials or modify the design of its product without notification as part of the company's continuing product improvement program.

© Copyright Gardco Lighting 2001-2007. All Rights Reserved. International Copyright Secured.

A Genlyte Company

1611 Clovis Barker Road  
San Marcos, TX 78666  
800/227-0758  
512/753-1000  
Fax: 512/753-7855  
www.sitelighting.com

