

# 806 Series

A01 - Floor to Floor

A02 - Floor to Wall



Movement Rating  $\pm 50\%$

## Product Guide



Thermal



Exterior



Interior



Fire Rated  
Option



Vapor Barrier  
Option

- ▶ Designed for uneven slab conditions
- ▶ Pre-drilled counter-sunk holes for easy installation
- ▶ Applicable for existing conditions, additions and new construction
- ▶ Anti-slip surface serrations

Application	System	W		H1		H2		S		B		Movement			
		Joint Width		Frame Height 1		Height 2		Sightline		Blockout		Horizontal +/-		Vertical (+ / -)	
		US	mm	US	mm	US	mm	US	mm	US	mm	US	mm	US	mm
Floor to Floor	806-A01-050	2"	51	1/4"	6	*	*	7"	178	*	*	$\pm 1"$	$\pm 25$	+1/4" / -1"	+6 / -25
	806-A01-100	4"	102	1/4"	6	*	*	10 1/2"	267	*	*	$\pm 2"$	$\pm 51$	+5/8" / -2"	+10 / -51
	806-A01-150	6"	152	1/4"	6	*	*	13"	330	*	*	$\pm 3"$	$\pm 76$	+7/8" / -2 3/4"	+13 / -71
	806-A01-200	8"	203	5/16"	8	*	*	17"	432	*	*	$\pm 4"$	$\pm 102$	+1" / -2 1/2"	+25 / -64
	806-A01-250	10"	254	5/16"	8	*	*	20"	508	*	*	$\pm 5"$	$\pm 127$	+1 3/8" / -3"	+35 / -76
Floor to Wall	806-A01-300	12"	305	5/16"	8	*	*	23"	584	*	*	$\pm 6"$	$\pm 152$	+1 5/8" / -3 1/2"	+41 / -90
	806-A02-050	2"	51	1/4"	6	*	*	4"	102	*	*	$\pm 1"$	$\pm 25$	+1/4" / -1"	+6 / -25
	806-A02-100	4"	102	1/4"	6	*	*	7 1/2"	191	*	*	$\pm 2"$	$\pm 51$	+5/8" / -2"	+10 / -51
	806-A02-150	6"	152	1/4"	6	*	*	10"	254	*	*	$\pm 3"$	$\pm 76$	+7/8" / -2 3/4"	+13 / -71
	806-A02-200	8"	203	5/16"	8	*	*	13"	330	*	*	$\pm 4"$	$\pm 102$	+1" / -2 1/2"	+25 / -64
	806-A02-250	10"	254	5/16"	8	*	*	17"	432	*	*	$\pm 5"$	$\pm 127$	+1 3/8" / -3"	+35 / -76
	806-A02-300	12"	305	5/16"	8	*	*	19"	483	*	*	$\pm 6"$	$\pm 152$	+1 5/8" / -3 1/2"	+41 / -90

IPC.921/REV.7

Inprocorp.com • 800.222.5556 • 262.679.9010  
World Headquarters S80 W18766 Apollo Drive, Muskego, WI 53150 USA

**JOINTMASTER®**  
EXPANSION JOINT SYSTEMS  
A DIVISION OF INPRO®

# 806 Series

## Hinged Cover Plate System

806-A01 Floor/Floor  
(2" (51mm) system shown)

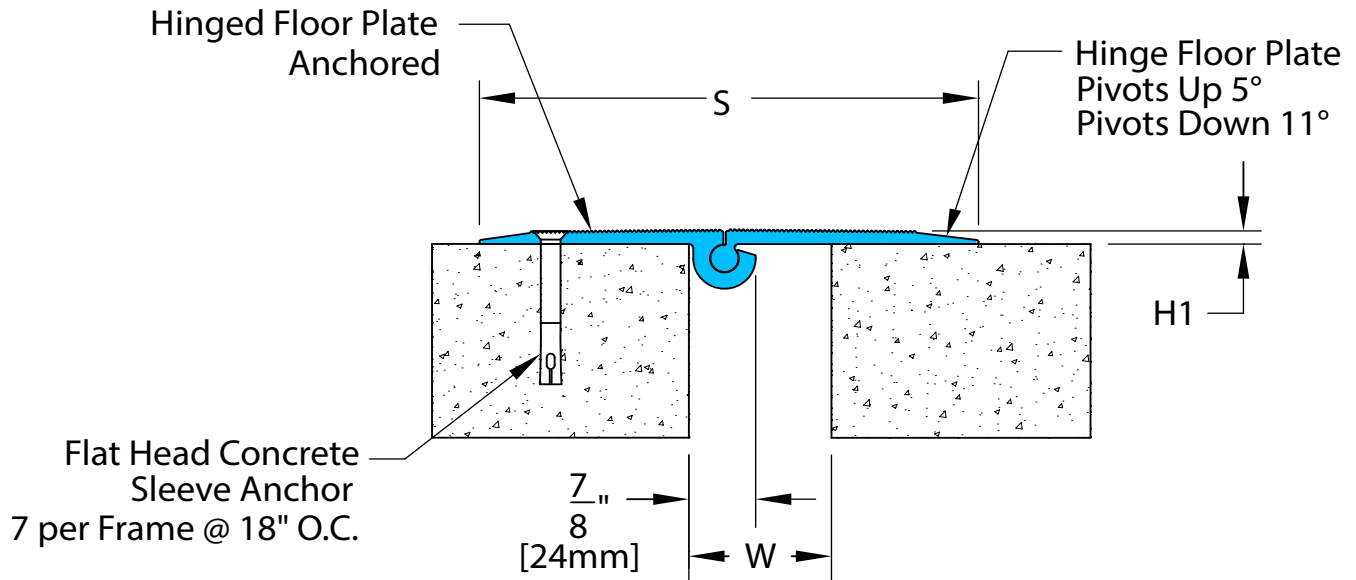

806-A02 Floor/Wall  
(2" (51mm) system shown)

Flat Head Concrete Sleeve Anchor  
(7 Per Frame @ 18" O.C.)

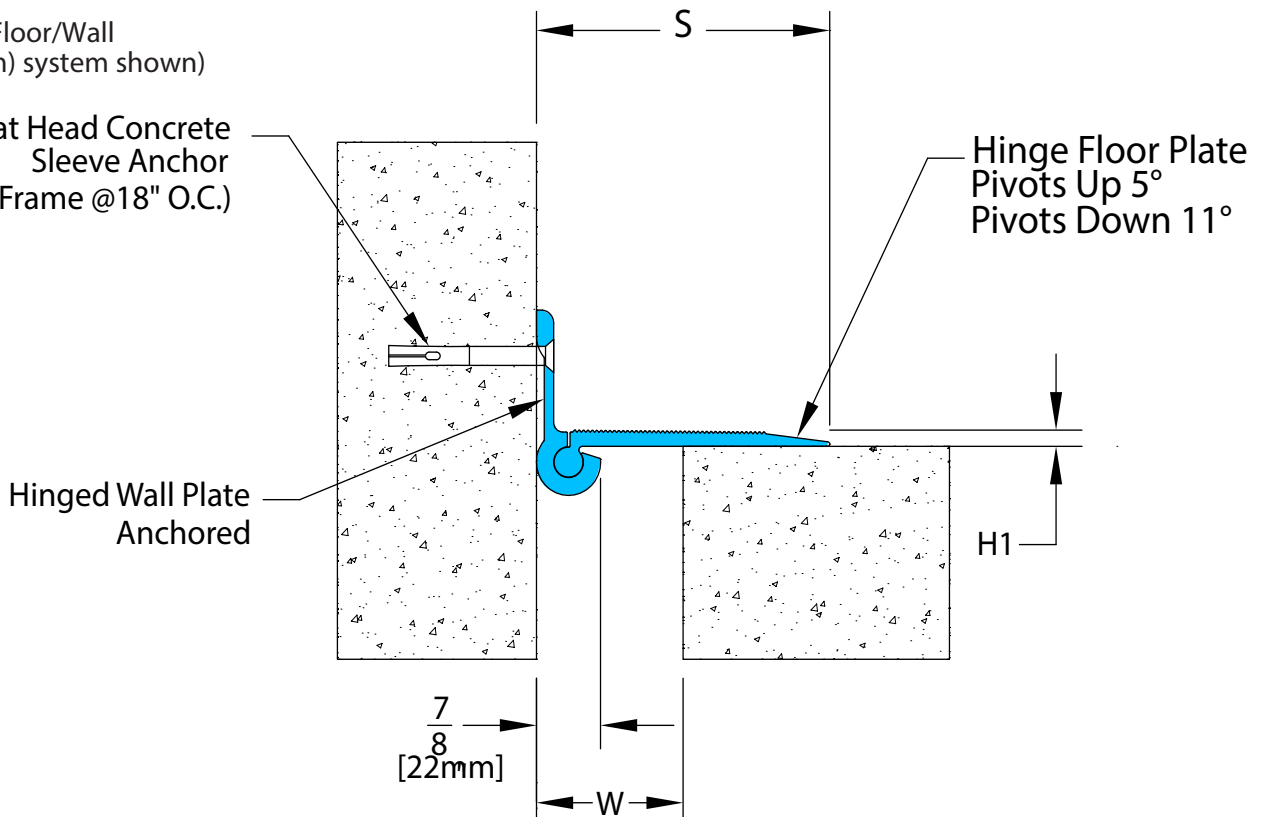

Inprocorp.com • 800.222.5556 • 262.679.9010

World Headquarters S80 W18766 Apollo Drive, Muskego, WI 53150 USA

**JOINTMASTER®**  
EXPANSION JOINT SYSTEMS  
A DIVISION OF INPRO®

# 806 Series

## Options

806-A01 Floor/Floor With Fire Barrier  
(2" (51mm) system shown)

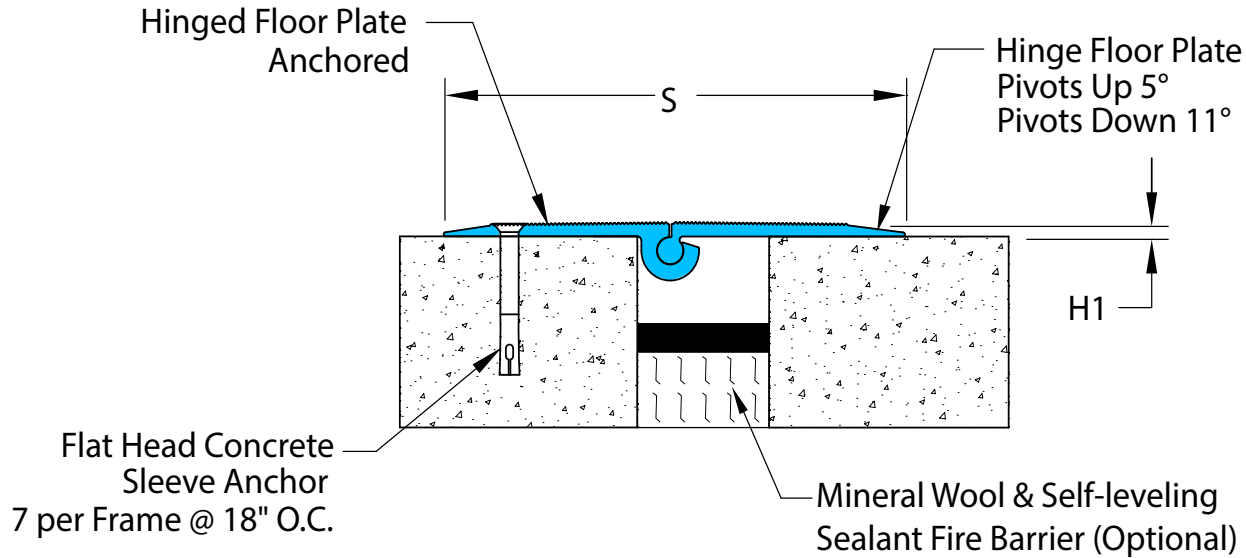

806-A01 Floor/Floor With Vapor Barrier  
(2" (51mm) system shown)

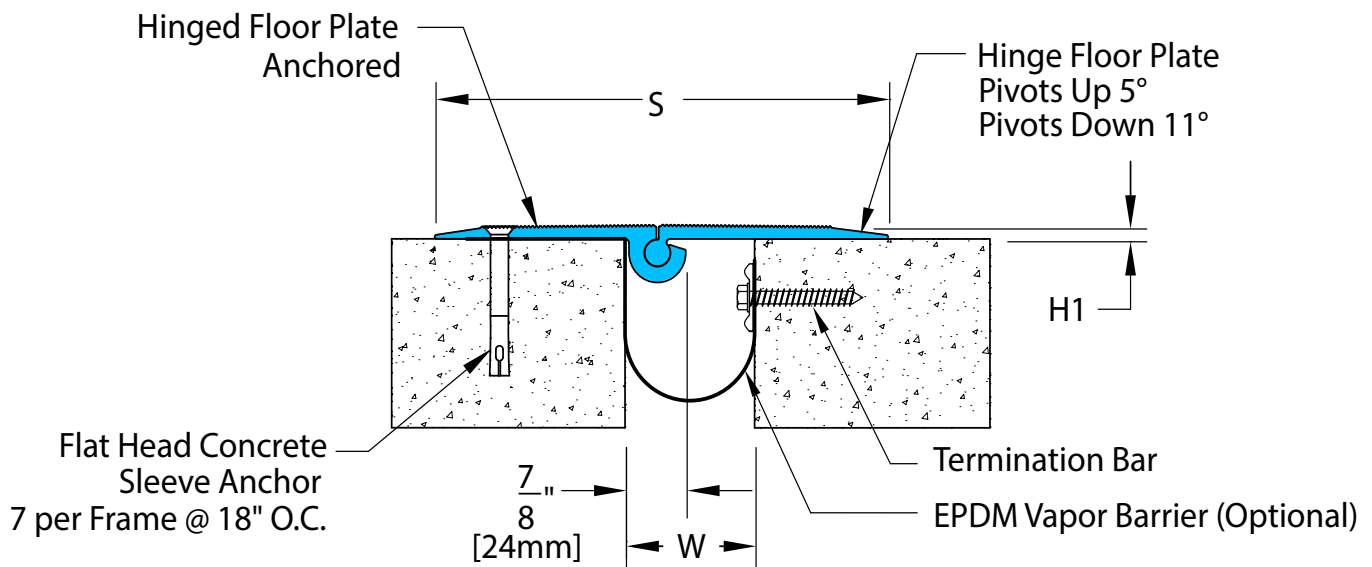

# 800 Series

## Suggested Specifications

### PART 1 - GENERAL

#### 1.01 SUMMARY

- A. Furnish Expansion Joint Systems in accordance with the drawings and general provisions of the Contract.

#### 1.02 WORK INCLUDED

- A. Furnish complete JointMaster/InPro Corporation Expansion Joint Systems.
1. Interior floor expansion joint systems.
  2. Interior wall expansion joint systems.
  3. Interior ceiling expansion joint systems.
  4. Exterior wall expansion joint systems.
  5. Exterior floor expansion joint systems.
  6. Parking deck expansion joint systems.
  7. Fire Rated Assemblies.

#### 1.03 RELATED WORK

- A. Related work which is specified elsewhere.
1. Cast-In-Place Concrete: Section 03300.
  2. Unit Masonry: Section 04200.
  3. Structural Steel: Section 05120.
  4. Light Gage Metal Framing: Section 05400.
  5. Sheet Metal Flashing and Trim: Section 7620.
  6. Cement Plaster: Section 09220.
  7. Gypsum Wallboard: Section 09250.

#### 1.04 REFERENCES

- A. Publications listed herein are part of this specification. See below for standards where applicable to the product listed:
1. American Society for Testing and Materials (ASTM):
    - a. ASTM B 221, Standard Specifications for Aluminum and Aluminum-Alloy Extruded Bars, Rods, Wire, Shapes, and Tubes.
    - b. ASTM B 209 "Standard Specifications for Aluminum and Aluminum Alloy Sheet and Plate."
    - c. ASTM E1399 "Cyclic Movement and Measuring of Minimum/Maximum Joint Widths of Architectural Joint Systems."

#### 1.05 DEFINITIONS

- A. Define industry and product terms as necessary.

#### 1.06 SYSTEM DESCRIPTION

- A. Joint systems shall permit limited movement of joint without disengagement.
1. Specify x-axis joint movement (horizontal).
  2. Specify y-axis joint movement (vertical, where applicable).
  3. Specify z-axis joint movement (lateral, where applicable).
- B. Allowable load on floor joint cover plate shall be 500 lbs. for standard loads, 1000 lbs. for moderate loads, and 2000 lbs. for heavy duty loads.
- C. Fire Rated Assemblies shall meet requirements of Underwriters Laboratories, in accordance with [ANSI/U.L. No. 263 and ASTM E 119/E 814] [UL 2079] [including hose stream test at full rated period]. Underwriter's Laboratories shall classify assemblies. Fire rating shall be not less than the fire rating of adjacent construction.

#### 1.07 QUALITY ASSURANCE

- A. Manufacturer: Furnish assemblies from one (1) manufacturer with a minimum of five (5) years of experience in the design, engineering and fabrication of expansion joint systems.
- B. Installer: Firm with not less than three (3) years of successful experience in the installation of systems similar to those

required by this project and acceptable to the manufacturer of the system.

#### 1.08 SUBMITTALS

- A. Manufacturer's specifications, technical data, installation instructions, and detail drawings for each system.
- B. Certificates or other documentation confirming UL approved compliance with fire resistance rating of fire barrier assemblies.
- C. Sample of specified systems where required.

#### 1.09 DELIVERY AND STORAGE

- A. Provide temporary protective covers on [anodized aluminum] [stainless steel] finished surfaces.
- B. Deliver joint systems to jobsite in new, clean, unopened cartons or crates of sufficient size and strength to protect materials during transit.
- C. Store components in original containers in a clean, dry location. Inspect materials upon arrival, monitor for adverse environmental impacts.

#### 1.10 SEQUENCING

- A. Submittals shall be completed and submitted within a reasonable amount of time after award of subcontract.
- B. Subcontract for the work of this section shall be planned to allow sufficient time for manufacturer's production and delivery scheduling.

#### 1.11 WARRANTY

- A. Standard JointMaster/InPro Corporation limited warranty against material and manufacturing defects for a period of not less than five (5) years when installed in accordance with manufacturer's recommendations.

### PART 2 - PRODUCTS

#### 2.01 MANUFACTURER

- A. JointMaster/InPro Corporation  
S80 W18766 Apollo Drive  
Muskego, WI 53150 USA  
Phone: (800) 222-5556  
Fax: (888) 715-8407  
Email: service@inprocorp.com
- B. Substitutions: Not permitted.

#### 2.02 MATERIALS

- A. Aluminum: ASTM B 221, alloy 6063-T6, 6005A-T61, and 5052-H32.
- B. Stainless Steel Plates (optional on 801 only): SS304.
- C. Elastomeric Seal (821 only): Co-extruded pleated vinyl. Color: White.
- D. Fire Barrier (optional): [925 Mineral Wool and Sealant System to UL2079] [935 Textiled Wool and Silicone Sealant System to UL2079] [950 Blanket System to UL2079 with hose stream test to walls] [F520 Blanket System to UL2079 with hose stream test to walls] or [990/995 Foam System to UL2079 with hose stream test to walls] required for indicated fire resistance rating.
- E. Fasteners, accessories and other materials required for complete installation in accordance with the manufacturer's instructions.
- F. Spring Clips (804 only): Stainless steel required.
- G. Gaskets (811 only): Vinyl gasket required.

#### 2.03 INTERIOR JOINT SYSTEMS FOR FLOORS, WALLS AND CEILINGS

#### A. JointMaster 800 Series - Standard Cover Plate System Profiles:

1. Floor Systems - Surface Mount, Floor/Floor or Floor/Wall
    - a. 801-A01 or A02, cover plate with beveled edges, suitable for all floor finishes.
    - b. 802-A01, cover plate with minimal sightline, accepts 1/8" [3mm], 1/4" [mm] and 3/8" [10mm] floor finishes.
    - c. 804-A01 or A02, cover plate with spring clip, suitable for all floor finishes.
    - d. 806-A01 or A02, serrated and hinged cover plate with leading edge ratio not to exceed 1:8 [7 degrees], suitable for all floor finishes.
    - f. 807-A01, hinged cover plate with minimal sightline, accepts 1/8" [3mm] or 3/8" [10mm].
    - g. 808-A01, serrated cover plate with beveled edges, suitable for all floor finishes.
  2. Wall/Ceiling Systems - Surface Mount, Wall/Wall (and Ceiling to Ceiling) or Wall/Corner (and Ceiling to Wall)
    - a. 804-A07 or A09, cover plate with spring clip, suitable for all wall finishes.
    - b. 811-A07 or A09, variable angle ratcheted cover plate system.
  3. Ceiling Systems - Flush Mount, Ceiling/Ceiling or Ceiling/Wall
    - a. 821-V24 or V23, Co-extruded pleated vinyl seal system for acoustical ceiling tile.
- B. JointMaster 800 Series - System Accessories:
- a. Fabric Reinforced Vapor Barrier for horizontal and vertical applications (as required).
  - b. Insulated Vapor Barrier for horizontal and vertical applications (as required).
  - c. Drainage Fittings for horizontal and vertical applications (as required).

#### 2.04 FABRICATION

- A. Field assemble components provided in standard lengths with pre-packaged fasteners and accessories.
- B. Fabricate special transitions and corner fittings as required.

#### 2.05 FINISHES

- A. Aluminum:
1. Floors: Mill finish
  2. Walls and Ceilings: Standard Class II Clear Anodized [Color Anodized] [Kynar Painted] [Custom Color Painted] [Brushed] optional.
- B. Stainless Steel: 2B

### PART 3 - EXECUTION

#### 3.01

- A. Verify that structural gap dimensions are in conformance with manufacturer's submittal data.

#### 3.02 INSTALLATION

- A. Joint systems: Install in accordance with manufacturer's instructions. Align work plumb, level and flush with adjacent surfaces. Rigidly anchor to substrate. Allowances should be made where actual structural gap at time of installation varies from nominal design gap.
- B. Fire Rated Assemblies: Where required, install to manufacturer's instructions.

#### 3.03 PROTECTION AND CLEANING

- A. Protect installation from damage by work of others. At completion of the installation, clean exposed surfaces with non-solvent cleaner.

#### END OF SECTION

Inprocorp.com • 800.222.5556 • 262.679.9010

World Headquarters S80 W18766 Apollo Drive, Muskego, WI 53150 USA

**JOINTMASTER®**  
EXPANSION JOINT SYSTEMS  
A DIVISION OF INPRO®