

Components

Letter	Description
E	Full End Panel
T	Top Panel
MC	Center Shelf
LC	Bottom Shelf Assembly
MO	Short End Panel
I	Back Panel

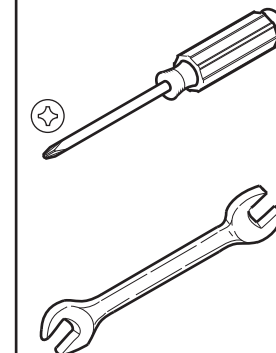
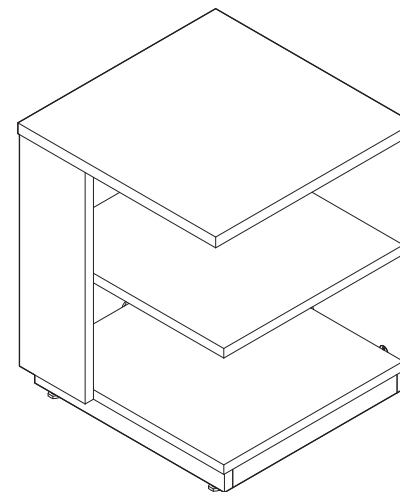
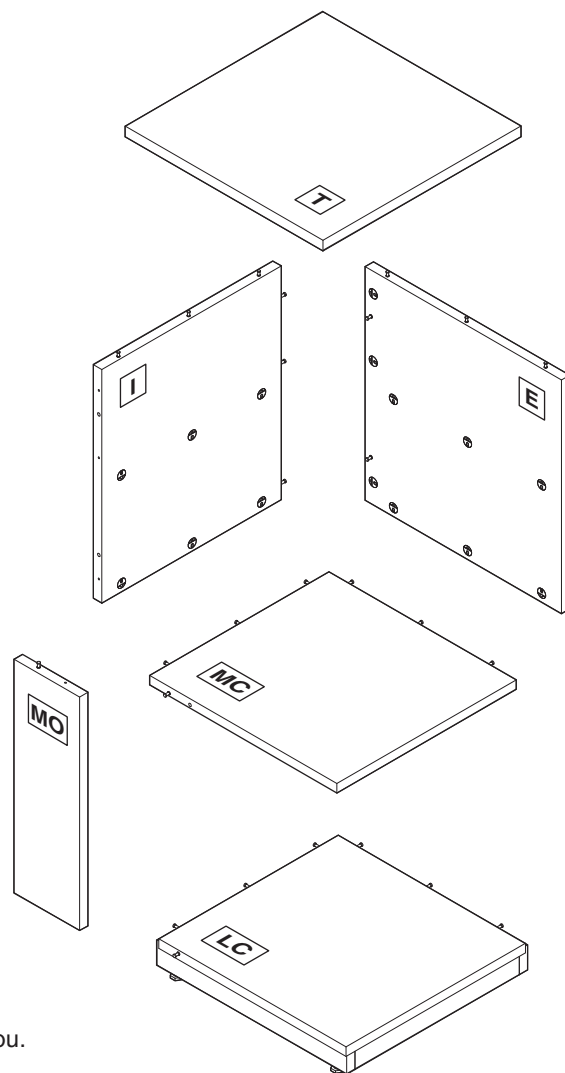

If you have a problem, question, or request, call your local dealer, or Steelcase Line 1 at **888.STEELCASE** (888.783.3522) for immediate action by people who want to help you.

(Outside the U.S.A., Canada, Mexico, Puerto Rico, and the U.S. Virgin Islands, call: 1.616.247.2500)
Or visit our website: www.steelcase.com

© 2012 Steelcase Inc.
Grand Rapids, MI 49501
U.S.A.

Printed in U.S.A.

(Tips for Proper Alignment of Parts)

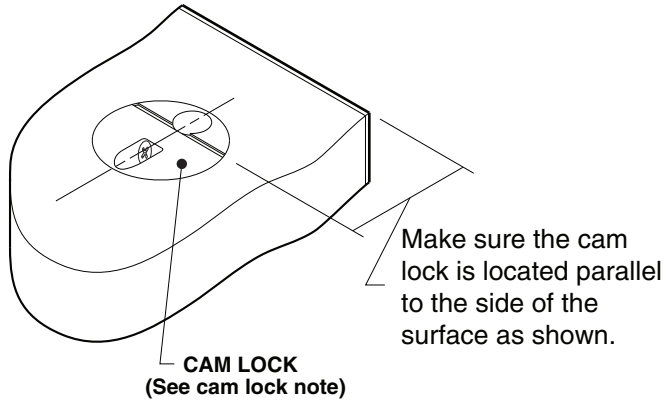

CAM LOCK NOTE:

If cam lock is installed high on the surface, tap it down flush with the surface. If that doesn't work, replace part.

If cam lock is installed low into the surface, screw cam pin out to extend the length of the cam pin.

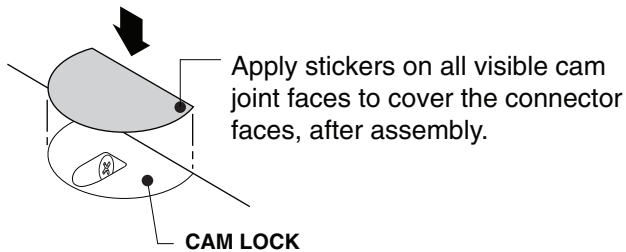

NOTE: When assembly has been completed, make sure to remove all of the E, B, T, ect. stickers from the surfaces of all the parts.

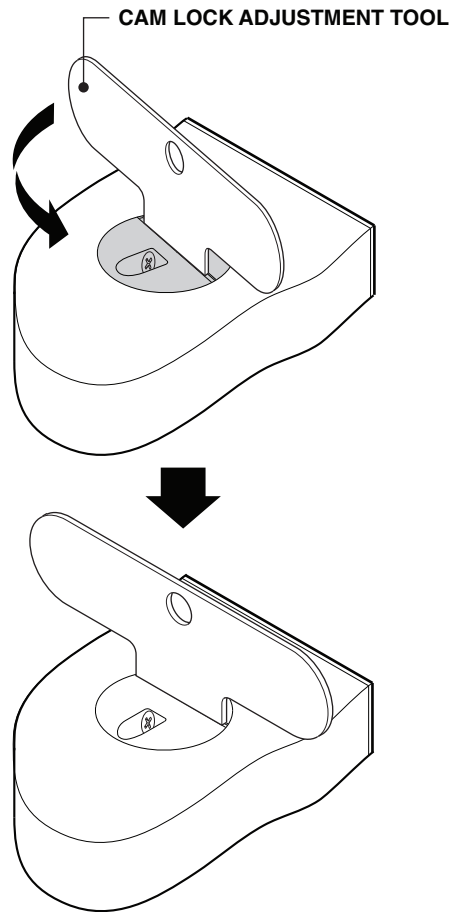

Use mallet, before tightening cam screws, to bring parts together and avoid light leaks.

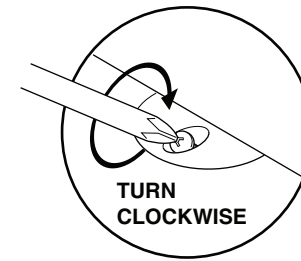

Fasten Cam Locks
(The cam lock screw needs to be turned 3/4 full turn or 270° clockwise for complete engagement.)

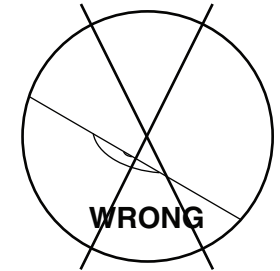

If the cam lock screw is not visible, you have installed the panel/shelf wrong and you need to turn the panel/shelf 180°.

NOTE: The cam pin is offset and needs to be installed on the shorter offset side. If the screw heads are not visible, turn the panel/shelf 180°.

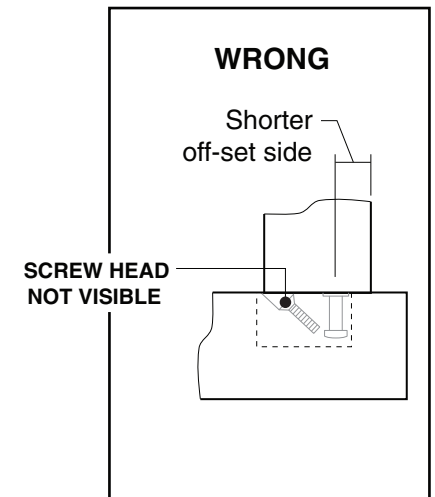
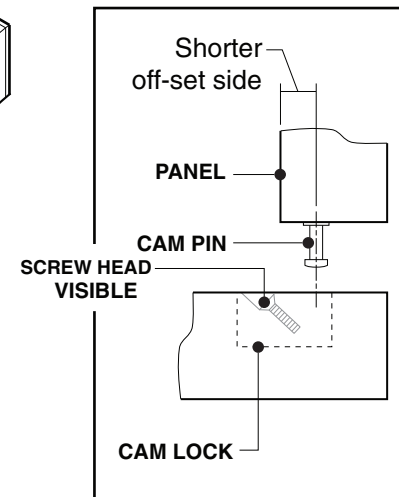

NOTE: Assemble as close to assembled units final desired location to avoid moving a heavy unit.

- 1.** Lower the MC (center shelf) and LC (bottom shelf assembly) onto the I (back panel) as shown. Make sure pins engage into cams (see page 2 for alignment of parts). Tighten cam locks.
- 2.** Tip the unit onto its side with the nine (9) pins pointing up. Lower the E (full end panel) onto the back panel, center shelf & bottom shelf assembly as shown. Make sure pins engage into cams (see page 2 for alignment of parts). Tighten cam locks.
- 3.** Tip the unit over with the E (full end panel) laying on the floor. Lower the MO (short end panel) onto the back panel, center shelf & bottom shelf assembly as shown. Make sure pins engage into cams (see page 2 for alignment of parts). Tighten cam locks.

Components	
Letter	Description
E	Full End Panel
T	Top
MC	Center Shelf
LC	Bottom Shelf Assembly
MO	Short End Panel
I	Back Panel

Fasten Cam Locks in 5 places
 (The cam lock screw needs to be turned 3/4 full turn or 270° clockwise for complete engagement.)

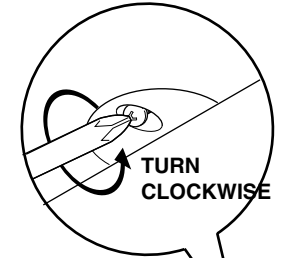

3

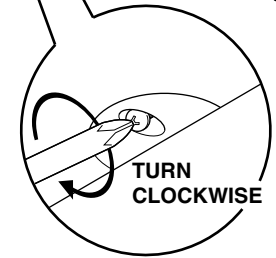
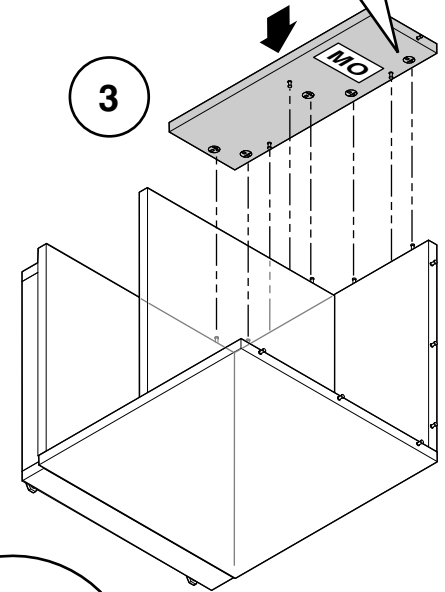

Fasten Cam Locks in 9 places
 (The cam lock screw needs to be turned 3/4 full turn or 270° clockwise for complete engagement.)

Fasten Cam Locks in 6 places
 (The cam lock screw needs to be turned 3/4 full turn or 270° clockwise for complete engagement.)

1

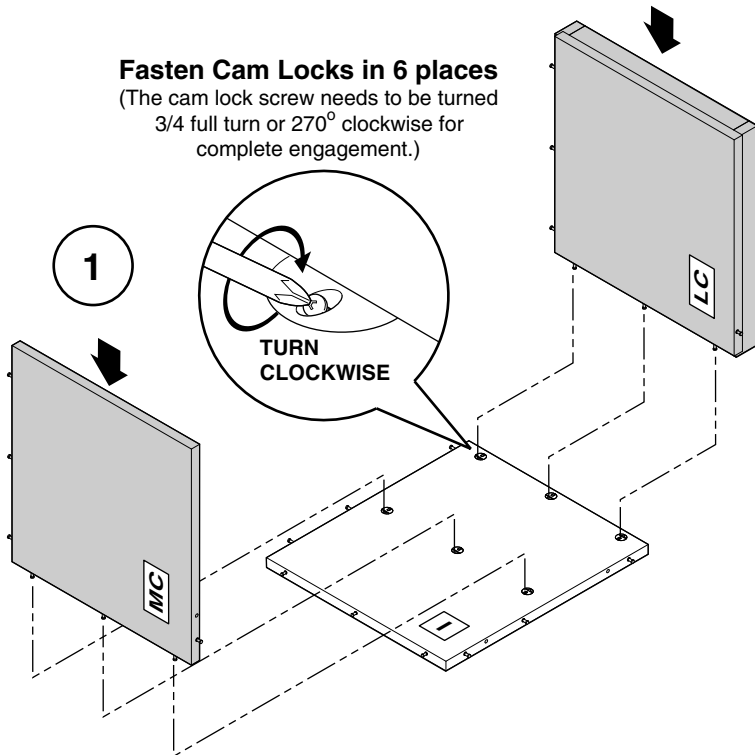

2

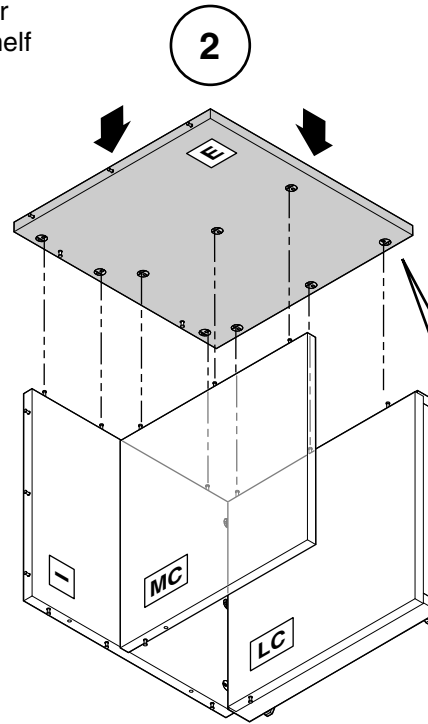

Components

Letter	Description
E	Full End Panel
T	Top
MC	Center Shelf
LC	Bottom Shelf Assembly
MO	Short End Panel
I	Back panel

4. Tip the unit into the upright position. Lower the T (top) onto the short end panel, full end panel & back panel as shown. Make sure pins engage into cams (see page 2 for alignment of parts). Tighten cam locks.

5. Adjust glides in four (4) places on the bottom of the unit. Level unit.

