

C700-Series Crash Rail

1. Locate and install Korogard Crash Rail in accordance with architectural drawings and specifications. When required, Korogard shop drawings should be used in conjunction with these documents.
2. Lay out the work to be completed, including all component parts, along the base of the wall. Check the material for any damage that may have occurred during shipment and/or handling at the job site.
3. Snap a chalk line at the proper location on the wall to ensure a level installation. Chalk line should be calculated to the center line of the wall fasteners.
4. Place the retainer in the proper position on chalk line and mark hole locations using the proper bit size for the selected wall fasteners.

Note: If the aluminum retainer has been supplied in stock lengths, it will be necessary for it to be field-cut. Determine the allowances necessary for door jambs, corner conditions, etc. (see next page) and cut retainer to proper length. Drill proper size holes at center of retainer 3" (76.2mm) in from each end and all intermediate locations not to exceed 32" (812.8mm) O.C.

5. Attach connector plates to ends of retainer using 1" (25.4mm) pan head screws as supplied.
6. Attach ends and corners with washers and machine nuts as supplied.
7. Attach splice joints with 1/4" (6.35mm) -20 x -1-1/2" (38.1mm) machine screws, washers, and nuts as supplied.
8. Mount assembly to wall using proper fasteners (not included). Tighten securely.

Note: Prior to installation of the Korogard cover, make sure that all fasteners are secure and properly seated.

9. Hold the Korogard cover at an angle and place the top of the cover behind the top of the retainer. Make sure that the cover is placed in the proper position and snap-fit the Korogard cover onto the aluminum retainer by placing hands downward and applying pressure with the heel of each hand to force the cover onto the retainer. Continue along until the complete length of the cover is securely installed.

10. If you have any questions during installation, please call your local Korogard representative.

Note: If the Korogard cover has been supplied in stock lengths, it will be necessary for it to be field-cut. Determine the distance from inside cap to inside cap. If this distance exceeds stock length, position seam of profile directly over the splice (connector plates) of the aluminum retainer. It is recommended that the Korogard cover be cut slightly oversize to provide proper alignment between the end caps. When cutting Korogard cover, it is recommended that a connector plate be placed inside and directly adjacent to the cut location to prevent distortion of the cover during cutting.

Mounting cushions vary based on model number:

- C700 Flush Mount
- C720 1,8" (3.18mm) Mounting Cushion
- C730 1,2" (12.7mm) Mounting Cushion (shown)
- C740 1-1,2" (38.1mm) Mounting Brackets
- C750 2" (50.8mm) Mounting Brackets

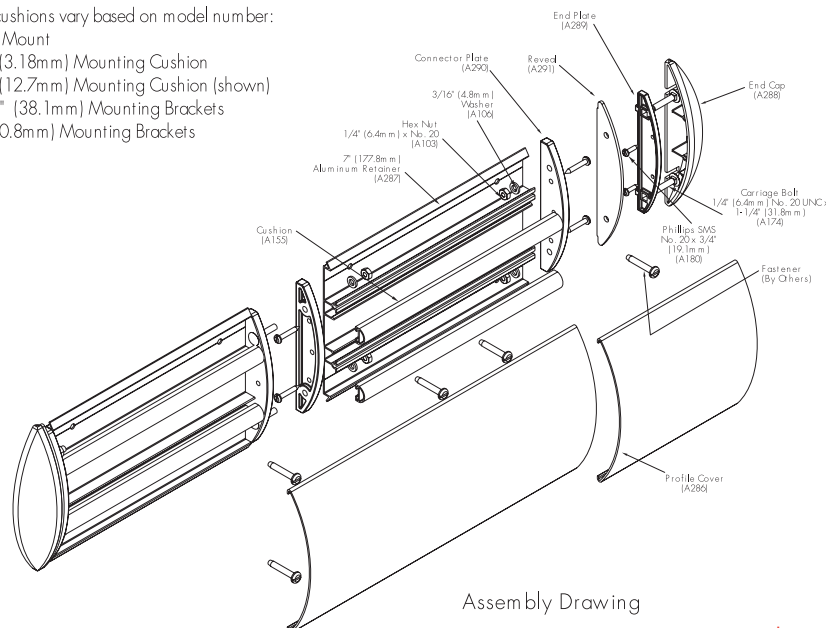

Installation Dimensions for
C700-Series Crash Rail

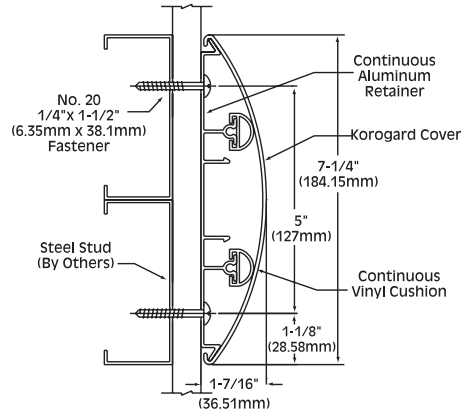

Model C700

