



STRIVE[®] SEATING

PRICE LIST

January 3, 2011

Updated May 4, 2022

800.424.2432

| | |
|---|----|
| Ordering COM, COL, COV and Shipping Location | |
| BONDUEL, GREEN BAY, ONTARIO, and TUPELO | 3 |
| Strive® Stack Seating | |
| General Information | 4 |
| Product Color Options | 10 |
| Stack Chairs | 11 |
| Dolly | 21 |
| Cafe Stool | 22 |
| Strive® High Density | |
| General Information | 23 |
| Product Color Options | 26 |
| Stack Chair and Dolly | 27 |
| Stack Stools | 28 |
| Strive® Nesting | |
| General Information | 29 |
| Product Color Options | 31 |
| Chairs | 32 |
| Strive® Nesting Chairs | 33 |
| Strive® Tandem Seating | |
| General Information | 34 |
| Product Color Options | 35 |
| 36 | |
| Strive® Task Seating | |
| General Information | 41 |
| Product Color Options | 45 |
| Chairs | 46 |
| Stools | 49 |



How to Specify C.O.M. Upholstery

Textile designs often have intricate patterns. Not all individuals will interpret fabric direction in the same manner.

As a standard procedure, KI cuts fabrics off the roll in a horizontal fashion as shown in Diagram A at the right. By cutting in this fashion, most waste is eliminated. Our requirements for yardage in this book are based on this type of cutting. When directional or patterned fabrics are used, they often require more yardage than solid colors.

By providing KI with a completely filled-out copy of the form on this page, we will be able to expedite your order. We find it particularly helpful with directional or patterned upholstery material. It is critical that copies of this form accompany test quantities as well as production quantities of C.O.M.

C.O.M. must be supplied in continuous yardage.

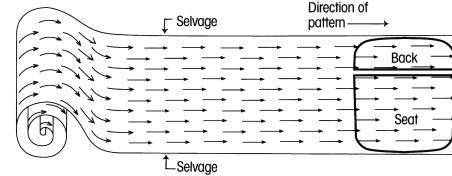

C.O.M., C.O.L. and C.O.V. Testing

KI will require for testing actual yardage to upholster one chair. The testing requirements depend on which chair you have selected on your order.

Test samples will be applied to the order and will be held for 6 months if needed. After 6 months, the sample can no longer be applied to your order. For all products to be tested, send test samples for approval to:

KI
Attn: C.O.M. Specialist
1687 Westminster Drive, Gate 3
Green Bay WI 54302

To expedite the procedure, attach a copy of the "C.O.M. Information Form" on this page.

All C.O.M., C.O.L. and C.O.V. must be labeled with the purchase order number.

C.O.M., C.O.L. and C.O.V. Production

Customer's fabrics and leathers must be approved prior to acceptance for production. Upon test approval, a 1" square sample swatch of upholstery material must accompany the order. KI assumes no responsibility for wear, defects or performance of customer's own fabrics, vinyl or leather. C.O.M., C.O.L. and C.O.V. orders are available on a deferred delivery basis.

Orders for production of C.O.M., C.O.L. and C.O.V. upholstered products are not scheduled for processing until upholstery material is received. Upon receipt, KI will provide an acknowledgement and an estimated shipping date.

KI recommends that leather be ordered in - yardage. Leather must be usable. The outer edges cannot be calculated as square feet or yardage.

The C.O.M., C.O.L. and C.O.V. yardage requirements accompanying products in the pricing section are for 10 chairs/seats or less, 54" wide nondirectional material. On larger orders, less material is required.

For exact production yardage requirements, call 1-800-424-2432, ext. 2707.

C.O.M., C.O.L. and C.O.V. Order Processing

For products shipped from Green Bay, WI facility, ship upholstery material to:

KI
Attn: C.O.M. Storage
1687 Westminster Drive - Gate 3
Green Bay, WI 54302

For products shipped from Bonduel, WI facility, ship material to:

KI
Attn: C.O.M. Storage
204 West South Street
Bonduel, WI 54107

For products shipped from Ontario, CA facility, ship material to:

Avail/Impress/Kismet/Medical & Laboratory Stools/Pilot
Attn: C.O.M. Storage
1110 S. Mildred Ave.
Ontario, CA 91761

Intricate Patterns

In the event of specific requirements for positioning of intricate patterns or pattern repeats on seats and backrests, provide a sketch noting requirements, as in Diagram B, along with materials for testing, and with the order.

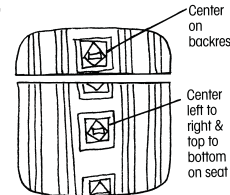

Diagram B

Treated Materials

If C.O.M. requires processing such as Scotchgard® or acrylic backing, it often shrinks. To prevent delays in delivery or back ordering due to shrinkage, please have your processor remeasure after processing and assure adequate yardage shipment.

Split Orders

If a portion of the shipment which does not require C.O.M., C.O.L. or C.O.V. applications is to be processed and shipped early, KI will enter the order immediately at your request. These split shipments are subject to minimum order changes.

Contact the C.O.M. Specialist at 1-800-424-2432, ext. 2707, with questions or to verify a split order.

Excess Upholstery Material

KI will dispose of excess upholstery material at the time of shipment unless expressly requested to return it with the product shipment.

Cancelled or Changed Orders

KI assumes no responsibility for extra C.O.M., C.O.L. or C.O.V. material due to a change of upholstery or cancellation of an order. It is the customer's responsibility to arrange for return of this material.

C.O.M. SHIPPING LOCATION

Architectural Walls

Evolve MN
Genius Walls MN

Casegoods

Aristotle Tackboards MN
Likha Tackboards MN

Classroom Furniture

Intellect Wave Chairs GB
Learn2 GB
Ruckus GB

Desking

700 Series Desking KP
Balance Overheads MN
Genesis Desking MN
True Desking KP
Universal Overheads MN
WorkZone Desking MN

Files & Storage

700 Series Pedestal Cushion GB
Connection Zone Pads BW
U-Series Pedestal Cushion GB
Tattoo BW

Fixed Seating

Concerto Auditorium Seating BW
Single Pedestal Seating GB
Jury Base Seating GB
Lancaster Auditorium Seating BW
Sequence Seating GB
University Seating GB

Panel Systems

All Terrain KP
Balance Overheads MN

System 3000 MN
Universal Overheads MN
Wireworks MN
Unite MN

Residence Hall Furniture

RoomScope Furniture MN

Screens

All Terrain KP
Connection Zone BW
True/Volition KP
Genesis KP
Tattoo MN
Universal BW

Seating

400 Series Folding Chairs BW
600 Series Folding Chairs BW
600 Series Stools BW
Affina Collection HN
Arissa Lounge HN
Altus Task Chairs GB
Apply Stack Chairs GB
Auditorium Folding Chairs BW
Calida Lounge Seating HN
Diem Task Chairs OM
Doni Collection GB
FourC Seating GB
Gladly Lounge Seating VQ
Grazie Seating GB
Hiatus Sleeper Bench HN
Hub Modular Lounge Seating HN
Impress Task Chairs OM
Impress Ultra Task Chairs OM
Jessa Lounge Seating HN
Jubilee Lounge Seating VQ
Katera Guest Chair GB

Kurv Benches HN
LaResta Day Beds HN
Lyra Lounge Seating HN
Maestro Stack Chairs GB
Matrix Stack Chairs GB
Medical & Laboratory Stools OM
MyPlace Lounge Seating HN
MyWay Seating HN
Oath Task Chairs and Stools GB
Opt4 GB
Pilot Task Chairs OM
Promenade Seating System BW
Ruckus GB
Sela Lounge Seating HN
Sift Task Chairs GB
Soltice Metal Collection HN
Soltice Multiple, Healthcare & Guest HN
Soltice II Healthcare Seating HN
Strive Multiple, Stack & Task GB
Sway BW
Tattoo HN
Torsion-on-the-Go! Nesting Chairs GB
Torsion Air Stack and Task Seating GB
Zoetry HN



C.O.M., C.O.L. and C.O.V. Information Form

A copy of this form should accompany test requests and production orders. Please fill it out completely, and, if your order has been acknowledged, provide the acknowledgement number.

Purchasing Agent (Dealer or buying organization)

Attention

Address

City

State

Zip

Project Name

Type of seating and number of units of each type

Please see information below and check the appropriate box.

Submitted for testing.

Test approved. Submitted for production.

Purchase Order Number

KI Acknowledgement Number

In all instances, send this form to the C.O.M. Specialist.

A Selvage Top and Bottom



B Selvage Side and Side



KI Manufacturing Sites - Customer's Own Material Shipment Manufacturing Site Addresses

BW
KI Bonduel
Attn: COM Storage
204 West South St.
Bonduel, WI 54107

HN
KI High Point
Attn: COM Storage
217 Feld Avenue
High Point, NC 27263

MN
KI Manitowoc
Attn: COM Storage
1400 S. 41st St.
Manitowoc, WI 54220

VQ
KI
Attn: COM Fabrics
6892 Marlin Circle
La Palma, CA 90623

GB
KI Green Bay
Attn: COM Storage
1687 Westminster Drive - Gate 3
Green Bay, WI 54302

KP
KI Pembroke
Attn: COM Storage
1000 Olympic Dr.
Pembroke, Ontario K8A6X7

OM
KI
Attn: COM Storage
1110 S. Mildred Ave.
Ontario, CA 91761

Strive® Stack Seating

General Information



Strive® Stack Seating

General Information



Armless Four-Leg Chair (SLNAU)



Four-Leg Cantilever Arm Chair (SLCAP)



Four-Leg Loop Arm Chair (SLLAU)

| Features | | | |
|--|--------------------|--------------------|--------------------|
| Stackable | • | • | • |
| Poly, upholstered seat, or upholstered seat/back | • | • | • |
| Flex back | • | • | • |
| General Dimensions | | | |
| Seat width | 18" | 18" | 18" |
| Seat depth | 18" | 18" | 18" |
| Seat height (upholstered add 1") | 18" | 18" | 18" |
| Overall Dimensions | | | |
| Width | 20-3/4" | 25" | 25" |
| Depth | 21-3/4" | 21-3/4" | 21-3/4" |
| Height | 32-1/2" | 32-1/2" | 32-1/2" |
| Arms to floor | | 26-1/4" | 26-1/4" |
| Stacking on Dolly | | | |
| Overall width | 24" | 25" | 25" |
| Overall depth - poly | 40" | 40" | 40" |
| Quantity/height - poly | 15 Chairs/61" High | 15 Chairs/62" High | 15 Chairs/63" High |
| Overall depth - upholstered | 45" | 45" | 45" |
| Quantity/height - upholstered | 8 Chairs/50" High | 8 Chairs/51" High | 8 Chairs/51" High |
| Stacking on Floor | | | |
| Width | 20-3/4" | 25" | 25" |
| Depth | 27-1/2" | 27-1/2" | 27-1/2" |
| Quantity/height | 4 Chairs/39" High | 4 Chairs/39" High | 4 Chairs/39" High |



Armless Four-Leg Chair with Casters (SLNAPC)



Four-Leg Cantilever Arm Chair with Casters (SLCAUC)



Four-Leg Loop Arm Chair with Casters (SLLAUC)



Armless Sled Base Chair (SSNAP)

Sled Base Cantilever Arm Chair (SSCAU)

| Features | | | | | |
|--|-------------------|-------------------|-------------------|--------------------|--------------------|
| Stackable | • | • | • | • | • |
| Poly, upholstered seat, or upholstered seat/back | • | • | • | • | • |
| Flex back | • | • | • | • | • |
| General Dimensions | | | | | |
| Seat width | 18" | 18" | 18" | 18" | 18" |
| Seat depth | 18" | 18" | 18" | 18" | 18" |
| Seat height (upholstered add 1") | 18-1/4" | 18-1/4" | 18-1/4" | 18-1/4" | 18-1/4" |
| Tablet to chair back clearance | | | | | |
| Overall Dimensions | | | | | |
| Width | 21-1/4" | 25" | 25" | 20-3/4" | 25" |
| Depth | 22-1/2" | 22-1/2" | 22-1/2" | 21-3/4" | 21-3/4" |
| Height | 32-1/2" | 32-1/2" | 32-1/2" | 32-1/2" | 32-1/2" |
| Arms to floor | | 26-1/2" | 26-1/2" | | 26-1/2" |
| Stacking on Dolly | | | | | |
| Width | | | | 24" | 25" |
| Depth - poly | | | | 48" | 48" |
| Quantity/height - poly | | | | 15 Chairs/64" High | 15 Chairs/64" High |
| Depth - upholstered | | | | 48" | 48" |
| Quantity/height - upholstered | | | | 8 Chairs/50" High | 8 Chairs/50" High |
| Stacking on Floor | | | | | |
| Width | 20-3/4" | 25" | 25" | 20-3/4" | 25" |
| Depth | 27-1/2" | 27-1/2" | 27-1/2" | 27-1/2" | 27-1/2" |
| Quantity/height | 4 Chairs/39" High | 4 Chairs/39" High | 4 Chairs/39" High | 4 Chairs/39" High | 4 Chairs/39" High |

INFORMATION

C.O.M. Testing and Production Requirements

Not all materials are suitable for upholstering this product. A 1 yd. x 54" sample must be submitted and approved prior to acceptance of an order. If the fabric is directional in pattern or weave, the direction must be indicated on the submitted sample, and additional yardage may be requested.

Test samples must be sent to:

KI
Attn: C.O.M. Specialist
1687 Westminister Drive - Gate 3
Green Bay, WI 54302

Fabric Disclaimer

Fabric will be applied as swatched by the fabric manufacturer. Fabric that is required to be applied differently than is swatched will need a Modified Product Request written specifying the direction the fabric is to be applied.

Design

Designed by Giancarlo Piretti and manufactured in the USA by Krueger International, Inc. under license from Pro-Cord S.p.A

KI Color Match Program

KI offers the additional option of color matching paint, polypropylene, or wood stain through Product Modification Requests. Contact Customer Service for details.

Whatever you imagine, whatever you require, KI's Color Match program lets you pick your color!

[Color Match Process - Poly Seating Information can be found here.](#)

INFORMATION

Warranty

Refer to KI Terms & Conditions document or visit ki.com

Strive® Stack Seating

General Information



Strive® Stack Seating

General Information



**Armless Wallsaver
Four-Leg Chair
(SLNAU)**



**Four-Leg Wallsaver
Cantilever Arm Chair
(SLCAP)**



**Four-Leg Wallsaver
Loop Arm Chair
(SLLAU)**

| Features | | | |
|--|-------------------|-------------------|-------------------|
| Stackable | • | • | • |
| Poly, upholstered seat, or upholstered seat/back | • | • | • |
| Flex back | • | • | • |
| General Dimensions | | | |
| Seat width | 18" | 18" | 18" |
| Seat depth | 18" | 18" | 18" |
| Seat height (upholstered add 1") | 17-1/2" | 17-1/2" | 17-1/2" |
| Overall Dimensions | | | |
| Width | 20-3/4" | 25" | 25" |
| Depth | 22-3/4" | 22-3/4" | 22-3/4" |
| Height | 33" | 33" | 33" |
| Arms to floor | | 26-1/4" | 26-1/4" |
| Stacking on Floor | | | |
| Width | 20-3/4" | 25" | 25" |
| Depth | 28-1/2" | 28-1/2" | 28-1/2" |
| Quantity/height | 4 Chairs/39" High | 4 Chairs/39" High | 4 Chairs/39" High |



**Four-Leg Armless Cafe Stool -
24" or 30" Seat Height
(SLSNAU)**



**Four-Leg Loop Arm Cafe Stool -
24" or 30" Seat Height
(SLSLAP)**



**Four-Leg Cantilever Arm Cafe Stool -
24" or 30" Seat Height
(SLSCAUB)**



**Transport Dolly
(SCDA.BL)**

| Features | | | | |
|--|--------------------------|--------------------------|--------------------------|---------|
| Stackable | • | • | • | |
| Poly, upholstered seat, or upholstered seat/back | • | • | • | |
| Flex back | • | • | • | |
| General Dimensions | | | | |
| Seat width | 18" | 18" | 18" | |
| Seat depth | 18" | 18" | 18" | |
| Seat height (upholstered add 1") | 24" / 30" | 24" / 30" | 24" / 30" | |
| Overall Dimensions | | | | |
| Width | 25" | 25" | 25" | 24" |
| Depth | 23-1/2" / 25" | 23-1/2" / 25" | 23-1/2" / 25" | 29" |
| Height | 39-1/4" / 45-1/4" | 39-1/4" / 45-1/4" | 39-1/4" / 45-1/4" | 16-1/2" |
| Arms to floor | 32-1/2" / 38-1/2" | 32-1/2" / 38-1/2" | 32-1/2" / 38-1/2" | |
| Stacking on Floor | | | | |
| Width | 25-7/8" | 25-7/8" | 25-7/8" | |
| Depth | 28" | 28" | 28" | |
| Quantity/height | 4 Chairs/48" or 54" High | 4 Chairs/48" or 54" High | 4 Chairs/48" or 54" High | |

INFORMATION

C.O.M. Testing and Production Requirements

Not all materials are suitable for upholstering this product. A 1 yd. x 54" sample must be submitted and approved prior to acceptance of an order. If the fabric is directional in pattern or weave, the direction must be indicated on the submitted sample, and additional yardage may be requested. Test samples must be sent to:

KI
Attn: C.O.M. Specialist
1687 Westminster Drive - Gate 3
Green Bay, WI 54302

Fabric Disclaimer

Fabric will be applied as swatched by the fabric manufacturer. Fabric that is required to be applied differently than is swatched will need a Modified Product Request written specifying the direction the fabric is to be applied.

Design

Designed by Giancarlo Piretti and manufactured in the USA by Krueger International, Inc. under license from Pro-Cord S.p.A

KI Color Match Program

KI offers the additional option of color matching paint, polypropylene, or wood stain through Product Modification Requests. Contact Customer Service for details.

Whatever you imagine, whatever you require, KI's Color Match program lets you pick your color!

[Color Match Process - Poly Seating Information can be found here.](#)

INFORMATION

Warranty

Refer to KI Terms & Conditions document or visit ki.com

Strive® Stack Seating

General Information



Strive® Stack Seating

General Information



Four-Leg Tablet Arm Chair
(SLTAPRH)



Four-Leg Oversize Tablet Arm Chair
(SLOVTAURH)



Sled Base Tablet Arm Chair
(SSTAPRH)



Sled Base Oversize Tablet Arm Chair
(SLOVTAPRH)



Four-Leg ChangeUp Tablet Arm Chair
with Glides



Four-Leg ChangeUp Tablet Arm Chair
with Casters



Sled Base ChangeUp Tablet Arm Chair

| Features | | | | |
|--|---------|---------|---------|---------|
| Stackable | | | | |
| Poly, upholstered seat, or upholstered seat/back | • | • | • | • |
| Flex back | • | • | • | • |
| General Dimensions | | | | |
| Seat width | 18" | 18" | 18" | 18" |
| Seat depth | 18" | 18" | 18" | 18" |
| Seat height (upholstered add 1") | 18" | 18" | 18" | 18" |
| Tablet to chair back clearance | 14" | 14" | 14" | 14" |
| Overall Dimensions | | | | |
| Width (Use Position) | 24" | 24" | 24" | 24" |
| Depth (Use Position) | 27-3/4" | 31" | 27-3/4" | 31" |
| Height | 33" | 33" | 33-1/4" | 33-1/4" |
| Arms to floor | 28-1/2" | 28-1/2" | 28-1/2" | 28-1/2" |

| Features | | | |
|--|---------------|---------------|---------------|
| Stackable | | | |
| Poly, upholstered seat, or upholstered seat/back | • | • | • |
| Flex back | | | |
| General Dimensions | | | |
| Seat width | 18" | 18" | 18" |
| Seat depth | 18" | 18" | 18" |
| Seat height (upholstered add 1") | 18" | 18" | 18" |
| Tablet to chair back clearance | 16-1/4" | 16-1/4" | 16-1/4" |
| Overall Dimensions | | | |
| Width (Use Position) | 26-1/2" | 26-1/2" | 26" |
| Depth (Use Position) | 28" - 33-1/2" | 28" - 33-1/2" | 28" - 33-1/2" |
| Height | 33" | 33-1/4" | 33-1/4" |
| Arms to floor | 27-3/4" | 27-3/4" | 27-3/4" |

INFORMATION

C.O.M. Testing and Production Requirements

Not all materials are suitable for upholstering this product. A 1 yd. x 54" sample must be submitted and approved prior to acceptance of an order. If the fabric is directional in pattern or weave, the direction must be indicated on the submitted sample, and additional yardage may be requested. Test samples must be sent to:

KI
Attn: C.O.M. Specialist
1687 Westminster Drive - Gate 3
Green Bay, WI 54302

Fabric Disclaimer

Fabric will be applied as swatched by the fabric manufacturer. Fabric that is required to be applied differently than is swatched will need a Modified Product Request written specifying the direction the fabric is to be applied.

Design

Designed by Giancarlo Piretti and manufactured in the USA by Krueger International, Inc. under license from Pro-Cord S.p.A

KI Color Match Program

KI offers the additional option of color matching paint, polypropylene, or wood stain through Product Modification Requests. Contact Customer Service for details.

Whatever you imagine, whatever you require, KI's Color Match program lets you pick your color!

[Color Match Process - Poly Seating Information can be found here.](#)

INFORMATION

Warranty

Refer to KI Terms & Conditions document or visit ki.com



TECHNICAL SPECIFICATIONS

Backrest

Injection-molded polypropylene with integral steel cantilever springs. The combination of the slotted polypropylene back and the spring steel provides a supportive flexing back. Springs are nominal 4.5 mm diameter chrome silicon valve spring wire.

Seat and Shroud

Injection-molded polypropylene.

Optional Upholstered Seat

Molded urethane foam is attached to an injection-molded polypropylene seat board, then upholstered using a draw-string process. The assembled seat pad is attached to the seat by means of hidden fasteners. Note: upholstered seat is required with translucent poly backs.

Optional Upholstered Back

A 1/2" thick urethane foam is attached to an injection-molded polypropylene back board, then upholstered using a draw-string process. The assembled back pad is attached to the back by means of fasteners which are exposed and are color matched to the polypropylene.

Frames

Legs are 7/8" O.D. by 13-gauge tubular steel. Cross members are 1" O.D. by 14-gauge tubular steel and 7/16" diameter solid steel. All joints are welded. Frames are available in 4-leg or sled base configurations. Standard 4-leg rear legs angle 14° from vertical. Wallsaver rear legs angle 23° from vertical.

Frame Finishes

Frames are finished in either baked-on electrostatically-applied 30-degree gloss epoxy powder-coat paint, or bright nickel-chrome plating.

Arms

Optional cantilever arms or loop arms are available. When equipped with arms, the supporting structure is a continuation of the rear leg finished to match the frame color. The armcaps are injection-molded glass filled polypropylene matching the frame finish (when frame finish is Chrome, hammertones, or Starlight Silver metallic, armcaps match the seat and back color; when back is Diamond translucent, armcaps are Light Tone; when back is Pewter translucent, armcaps are Flannel; when back is Bronze translucent, armcaps are Chocolate). The armcaps are attached to the steel structure by means of screws.

Glides

Upper and lower ends of leg tubes are capped with polypropylene end caps matching leg color (chrome frames and hammertone frames match the seat and back color). Three optional glide types are available for leg chairs: swivel poly/nylon, swivel steel and swivel felt glides. The swivel function allows the bottom of the glide to correctly match un-even floor conditions, resulting in less wear. Poly/nylon and felt glides are interchangeable and have easy-on/easy-off replaceable glide caps, which makes field replacement easy and efficient. Swivel poly glides are available in Stone color only. Optional glides for the sled base are co-extruded to provide a softer (non-skid) surface to protect the floor, but do not glide. Sled base chairs are also available with black nylon (plastic) glides and stainless steel glides.

Casters

4-leg chairs may be ordered with carpet casters instead of glides (does not apply to café stools). Casters are double-wheel (60 mm) high-impact thermoplastic and are available in black only.

Tablet Arm

Tablet support loop is a continuation of the rear leg and is available in left- or right-handed models. A formed steel hinge is welded to the top of the support structure, and secured with screws to the underside of the writing surface. Writing surface is 9 1/2" x 20 3/4" x 12 1/2" plywood core of 5/8" thick, 1 1-ply hardwood, surfaced with .030" high-pressure laminate top and plain backer undersurface. Edges are lacquered and sealed.

4-Leg Café Stool

4-leg models on glides are available in 24" and 30" seat heights. Stool-height units are equipped with a reinforcing foot ring made of a 1/2" diameter wire ring, which is open in the back to allow stacking of armless and cantilever arm stools.

Transport Dolly

Frame construction is welded tubular steel with a black powder-coated finish and 5" wheels (two swivel and two fixed). The dolly fits 4-leg or sled base chairs and has a capacity of fifteen poly chairs or eight upholstered chairs.

ChangeUp™ Tablet Arm

ChangeUp tablet support is integral to the chair frame and consists of a 7/8" diameter solid steel rod welded to the front and rear support tubes. A three-piece molded plastic armrest is included and attached to the chair frame using a #10 x 2 1/2" Phillips pan head tapping screw.

The tablet mechanism consists a die-cast aluminum housing, upper and lower plastic bearings, and 1 1-gauge steel clamp and tablet board support plates. The tablet mechanism is clamped onto the chair frame over two plastic bushing halves and a 5/16" diameter by 1 3/4" hardened steel pin with a die-cast aluminum cap secured with two 1/4-20 x 3/4" button socket head cap screws. The pin creates a solid 90° up/down pivot stop and the bushings provide a smooth, quiet operation. In the use position, the tablet mechanism rotates outward from the chair back an additional 20° and permits approximately 3 1/2" of adjustment for ingress/egress without stowing the tablet.

The tablet worksurface is 21" wide by 13 1/2" deep (235 square inches) is secured to the tablet board support plate with twelve #12 x 5/8" Phillips flat head tapping screws. The tablet board is made of 18 mm Baltic Birch plywood with .040" high-pressure laminate top surface and .02" thick phenolic backer surface for an overall board thickness of approximately 3/4". Edges are lacquered with a clear finish and sealed. The factory installed tablet assembly is not field installable and may not be removed.

Compliance

Support frame, mechanism and worksurface passes KI's internal testing for 250-pound weight capacity.



STATEMENT OF LINE

All models are available in polypropylene seat/backrest, upholstered seat/ polypropylene backrest, or upholstered seat/backrest.

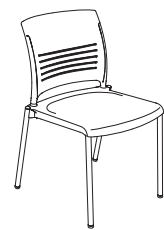

SLNAP

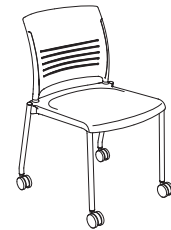

SLNAPC



SLCAP



SLCAPC



SLLAP



SLLAPC



SLTAPRH



SLOVTAPRH



SLNAPWS



SLCAPWS



SLLAPWS

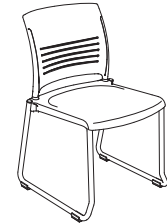

SSNAP

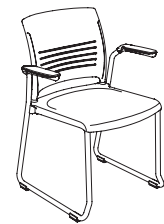

SSCAP

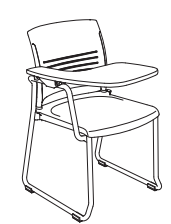

SSTAPRH



SSOVTAPRH



SLCUTAPRH



SLCUTAPCRH



SSCUTAPRH



SLSNAP

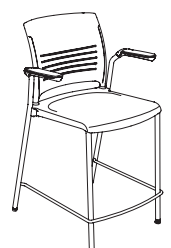

SLSCAP



SLSLAP

DIMENSIONS

Strive Armless 4-Leg Chair

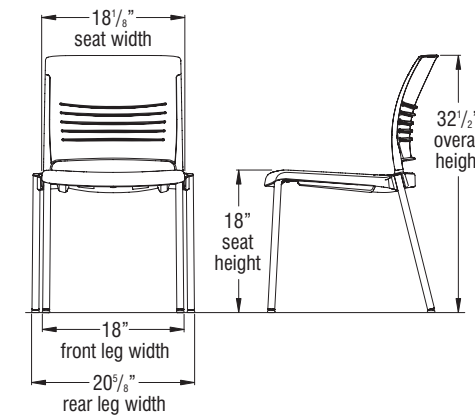

Strive Armless 4-Leg Chair with Casters

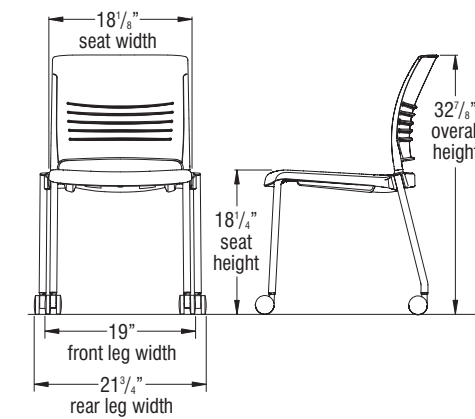

Strive Armless Sled Base Chair

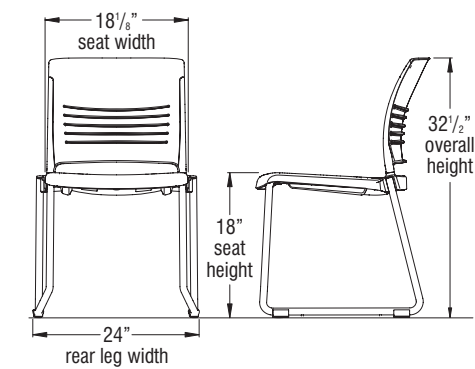

Strive 4-Leg Cantilever Armchair

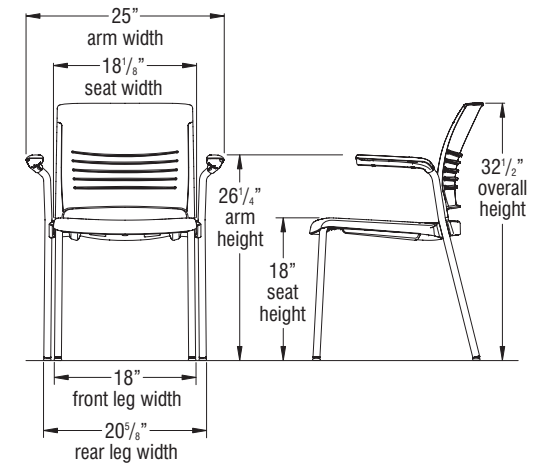

Strive 4-Leg Loop Armchair

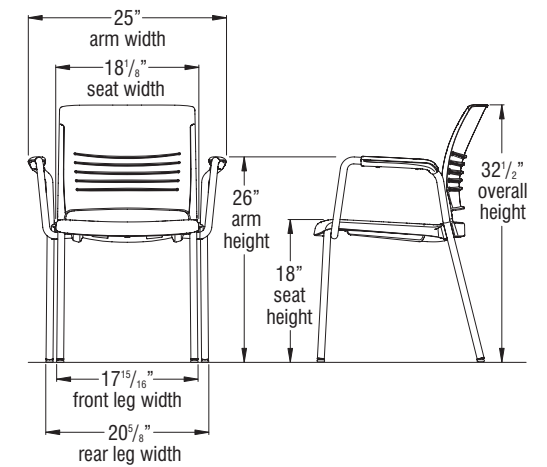

Strive Armless Sled Base Chair

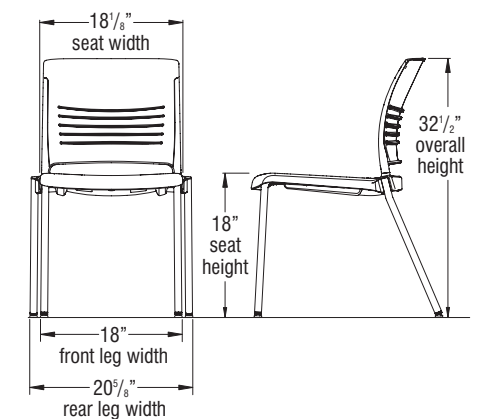

Strive 4-Leg Tablet Armchair

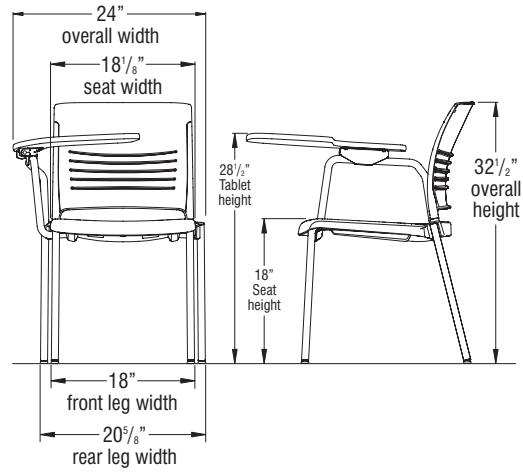

Strive 4-Leg Oversized Tablet Armchair

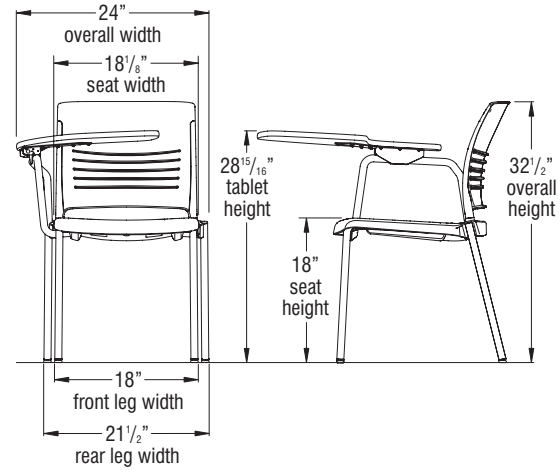

Strive 4-Leg ChangeUp Tablet Armchair

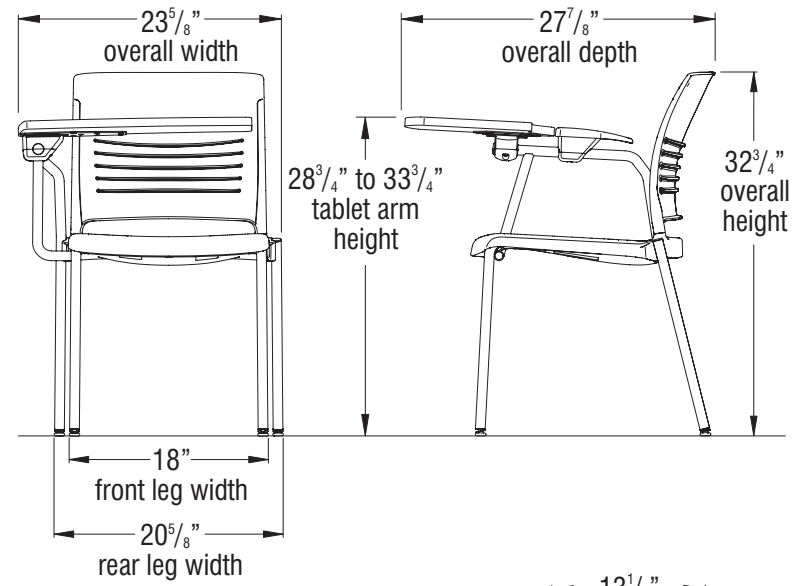

Strive Armless 4-Leg Café Stool

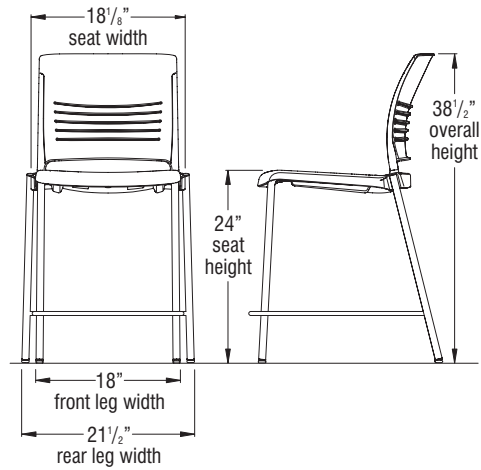

Strive 4-Leg Cantilever Arm Café Stool

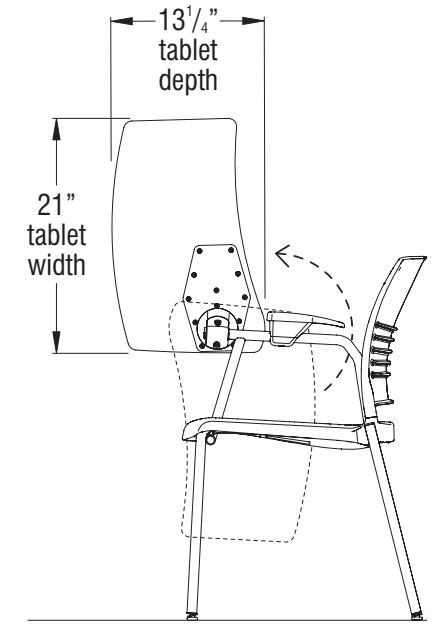
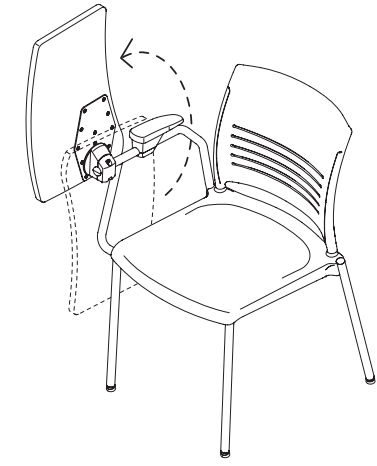
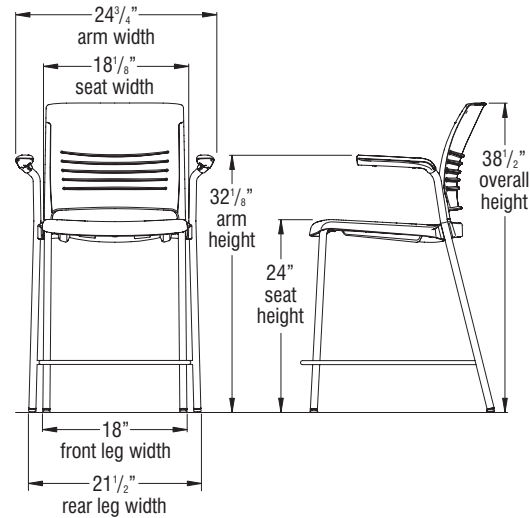

Strive 4-Leg Arm Café Stool

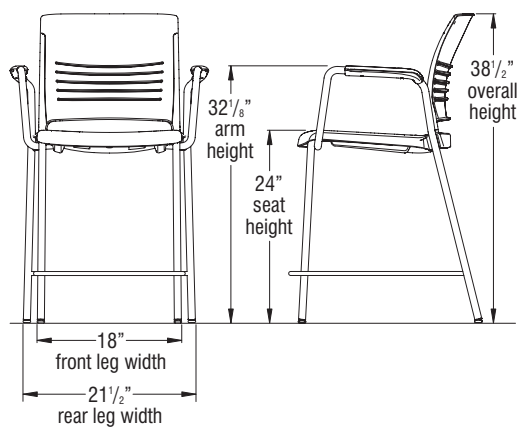

Strive Armless 4-Leg Café Stool

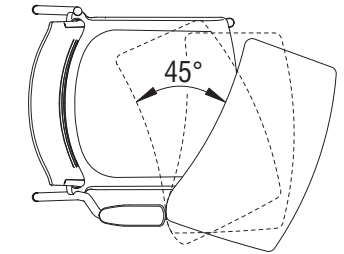
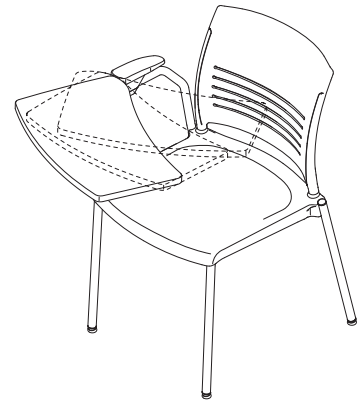
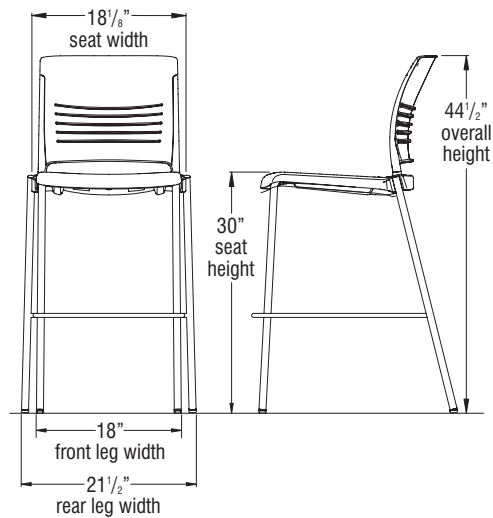

**Frame Color**

Black
Blue Grey
Bronze Metallic
Cayenne
Champagne Metallic
Chrome
Cool Grey
Cottonwood
Earthen Clay
Espresso Metallic
Everglade Shade
Flannel
Glitz Metallic
Hazy Jade
Honey Bee
Light Tone
Mardi Gras
Misty Brown
Nemo
Nordic
Poppy Red
Purple Haze
Rubber Ducky
Sand
Sky Blue
Starlight Silver Metallic
Surf's Up
Twilight Shadow
Ultra Blue
Warm Grey
Zesty Lime

BL
GR
ZM
CY
CM
CH
CG
CO
EY
EX
EV
FN
GZ
HJ
HY
LG
MG
MY
NE
ND
PR
PH
RK
SA
SK
SX
SP
TI
UB
WG
ZL

**Seat and Back Color - Polypropylene
Non Flame-Retardant**

Black
Blue Grey
Cayenne
Cool Grey
Cottonwood
Diamond Translucent
Earthen Clay
Everglade Shade
Flannel
Hazy Jade
Honey Bee
Light Tone
Mardi Gras
Misty Brown
Nemo
Nordic
Pewter Translucent
Poppy Red
Purple Haze
Rubber Ducky
Sand
Sky Blue
Surf's Up
Twilight Shadow
Ultra Blue
Warm Grey
Zesty Lime

Diamond Translucent and Pewter Translucent are only available on upholstered seat models.

**Seat and Back Color - Polypropylene
Flame-Retardant**

Black PBL

The above seating product can be manufactured using the appropriate flame-retardant materials for compliance to California Technical Bulletin 133.

*NOTE: When FR upholstery is selected, FR poly (black only) must be selected. NFR poly is not available with FR upholstery.

Tablet Arm Color - Laminate

Belair
Biltmore Cherry
Black
Brighton Walnut
Canyon Zephyr
Castle Oak
Casual Linen
Cherry Storm
Classic Linen
Cloud Zephyr
Cocobala
Crisp Linen
Desert Zephyr
Dove Grey
Fired Steel
Flax Linen
Florence Walnut
Forged Steel
Friston Ash
Frosty White
Graphite Nebula
Grey
High Rise
Hollyberry
Irish Linen
Island
Italian Silver Ash
Kensington Maple
Lapis Blue
Markerboard White
Misted Zephyr
Monticello Maple
Nickel Evolv
North Sea
Ocean
Pearl Bisque
Pearl Silver
Pressed Linen
River Cherry
Rugged Linen
Satin Stainless
Shadow Zephyr
Silicon evolv
Sterling Ash
Tailored Linen
Titanium evolv
White Nebula
White Sand
Windsor Mahogany

LBQ
LBT
LBK
LBW
LCA
LCO
LCU
LCX
LCI
LCL
LCC
LRI
LDZ
LDG
LIL
LXF
LFC
LOL
LFH
LFW
LGN
LGE
LHE
LHY
LIH
LID
LIT
LKM
LLB
LMK
LMR
LMT
LNV
LNA
LON
LPB
LPS
LPR
LRY
LRG
LSS
LSR
LSV
LAZ
LTL
LTV
LWL
LWN
LWY

Arm caps and glides match the frame color with the following exceptions:

-When frame color is chrome or metallic, the arm caps and glides will match poly color.

-When back is diamond translucent, arm caps are light tone.

-When back is pewter translucent, arm caps are flannel.

Casters for four-leg chairs are always black.

Finish Cards

View color swatches for items listed within this document.

Paints**Plastics/Poly****Wood/Veneer****Laminates****Molded Edges****Edge Styles****Hard Plastics****Glass**

Certain options referenced may not be available on GSA Schedule.



| MODEL | | MODEL NUMBER | | | | | | | Approx. Packaged Weight | Delivered Pricing Unupholstered | Delivered Pricing Fabric Grade 1 & C.O.M. | Delivered Pricing Fabric Grade 2 | Delivered Pricing Fabric Grade 3 | Delivered Pricing C.O.V. | Delivered Pricing Vinyl Group 2V | Delivered Pricing Pallas Fabric Group P0 | Delivered Pricing Pallas Fabric Group P1 | Delivered Pricing Pallas Fabric Group P2 | Delivered Pricing Pallas Fabric Group P3 | Delivered Pricing Pallas Fabric Group P4 |
|---|-------------------------|--------------|--------------------------|--------------------------|--------------------------|--------------------------|--------------------------|--------------------------|-------------------------|---------------------------------|---|----------------------------------|----------------------------------|--------------------------|----------------------------------|--|--|--|--|--|
| | | Basic Model | Frame Color | Seat & Back Color | Caster Type | Glide Option | Fire Code | Upholstery Color | | | | | | | | | | | | |
| <p>Four-Leg Armless Chair • Flex back • Stacking</p> | Polypropylene | SLNAP | <input type="checkbox"/> | <input type="checkbox"/> | | <input type="checkbox"/> | <input type="checkbox"/> | 20.0# | \$ 235 | | | | | | | | | | | |
| | Upholstered Seat | SLNAU | <input type="checkbox"/> | <input type="checkbox"/> | | <input type="checkbox"/> | <input type="checkbox"/> | 23.0# | N/A | 311 | 346 | 361 | 311 | 361 | 358 | 404 | 428 | 455 | 477 | |
| | Upholstered Seat/Back | SLNAUB | <input type="checkbox"/> | <input type="checkbox"/> | | <input type="checkbox"/> | <input type="checkbox"/> | 23.0# | N/A | 376 | 411 | 425 | 376 | 425 | 424 | 470 | 494 | 520 | 541 | |
| <p>Four-Leg Armless Chair with Casters • Flex back • Stacking (Caution should be used if stacking to prevent casters from damaging chair and frame) • Stacking on dollies is NOT recommended</p> | Polypropylene, Casters | SLNAPC | <input type="checkbox"/> | <input type="checkbox"/> | <input type="checkbox"/> | | <input type="checkbox"/> | 26.0# | \$ 280 | | | | | | | | | | | |
| | Uph. Seat, Casters | SLNAUC | <input type="checkbox"/> | <input type="checkbox"/> | <input type="checkbox"/> | | <input type="checkbox"/> | 29.0# | N/A | 356 | 390 | 408 | 356 | 408 | 408 | 452 | 477 | 502 | 524 | |
| | Uph. Seat/Back, Casters | SLNAUBC | <input type="checkbox"/> | <input type="checkbox"/> | <input type="checkbox"/> | <input type="checkbox"/> | | <input type="checkbox"/> | 29.0# | N/A | 421 | 455 | 472 | 421 | 472 | 471 | 517 | 541 | 565 | 590 |
| | | | A | B | C | D | E | F | G | | | | | | | | | | | |

SLP
SLU
SLUB

SLP
SLU
SLUB

HOW TO ORDER

- Indicate the following information on order form:
- Quantity of each item.
 - Model number, including options. See "How To Build a Model Number".
 - Any special service required.

Note:

- The indicates that a choice is required.
- The absence of the indicates that no choice is required.
- Alpha-numeric characters in place of indicate that no other alternatives are available.

HOW TO BUILD A MODEL NUMBER

- A** Select basic model.
- B** Select frame color. Refer to the **Product Color Options** page in this price list.
- C** Select poly seat and back color. Refer to the **Product Color Options** page in this price list.
- D** Select casters.
- C** _____ - Carpet casters (black only)
S _____ - Hard floor casters (black only)
- E** Select glide option.
- F** _____ - Felt Glides
P _____ - Plastic glides
S _____ - Steel glides
- F** Select fire code.
- NFR** _____ - Compliance to TB 117-2013
FR _____ - Compliance to TB 133

G Select upholstery grade/color. Refer to ki.com/fabrics

UPHOLSTERY INFORMATION

C.O.M. Upholstery
C.O.M. requirement for 10 chairs or less with upholstered seat or upholstered seat and back is 3/4 yard per chair of 54" wide nondirectional fabric. For orders of 11 or more with upholstered seat and back and for complete information on ordering C.O.M. see "Ordering C.O.M., C.O.V. and C.O.L." section.

OPTIONS

California TB133 Fire Safety Code
For California Technical Bulletin 133 compliant models, add the following upcharge:

Model=Polypropylene
Added List Price=\$12

Model=Upholstered Seat
Added List Price=\$84

Model=Upholstered Seat and Back
Added List Price=\$119

SPECIAL SERVICES

Special Carton Marking
With specially marked information N/C

Shipping
Ships **assembled, FOB Green Bay, WI 54302, freight prepaid.** Freight class 125.

Specifications and prices are subject to change without prior notice.



| MODEL | | Features | MODEL NUMBER | | | | | | | Pricing | | | | | | | | | | | | |
|-------|--|-------------------------|--------------|--------------------------|--------------------------|--------------------------|--------------------------|-----------|--------------------------|-------------------------|---------------------------------|---|----------------------------------|----------------------------------|--------------------------|----------------------------------|--|--|--|--|--|--|
| | | | Basic Model | Frame Color | Seat & Back Color | Caster Type | Glide Option | Fire Code | Upholstery Color | Approx. Packaged Weight | Delivered Pricing Unupholstered | Delivered Pricing Fabric Grade 1 & C.O.M. | Delivered Pricing Fabric Grade 2 | Delivered Pricing Fabric Grade 3 | Delivered Pricing C.O.V. | Delivered Pricing Vinyl Group 2V | Delivered Pricing Pallas Fabric Group P0 | Delivered Pricing Pallas Fabric Group P1 | Delivered Pricing Pallas Fabric Group P2 | Delivered Pricing Pallas Fabric Group P3 | Delivered Pricing Pallas Fabric Group P4 | |
| | Four-Leg Cantilever Arm Chair | Polypropylene | SLCAP | <input type="checkbox"/> | <input type="checkbox"/> | | <input type="checkbox"/> | | | 23.0# | \$ 306 | | | | | | | | | | | |
| | • Flex back | Upholstered Seat | SLCAU | <input type="checkbox"/> | <input type="checkbox"/> | | <input type="checkbox"/> | | <input type="checkbox"/> | 26.0# | N/A | 383 | 417 | 429 | 383 | 429 | 429 | 476 | 500 | 525 | 548 | |
| | • Stacking | Upholstered Seat/Back | SLCAUB | <input type="checkbox"/> | <input type="checkbox"/> | | <input type="checkbox"/> | | <input type="checkbox"/> | 26.0# | N/A | 447 | 481 | 495 | 447 | 495 | 495 | 540 | 564 | 591 | 611 | |
| SLP | | | | | | | | | | | | | | | | | | | | | | |
| SLU | | | | | | | | | | | | | | | | | | | | | | |
| SLUB | | | | | | | | | | | | | | | | | | | | | | |
| | Four-Leg Cantilever Arm Chair with Casters | Polypropylene, Casters | SLCAPC | <input type="checkbox"/> | <input type="checkbox"/> | <input type="checkbox"/> | | | <input type="checkbox"/> | 28.0# | \$ 351 | | | | | | | | | | | |
| | • Flex back | Uph. Seat, Casters | SLCAUC | <input type="checkbox"/> | <input type="checkbox"/> | <input type="checkbox"/> | <input type="checkbox"/> | | <input type="checkbox"/> | 31.0# | N/A | 427 | 462 | 479 | 427 | 479 | 477 | 523 | 548 | 572 | 595 | |
| | • Stacking (Caution should be used if stacking to prevent casters from damaging chair and frame) | Uph. Seat/Back, Casters | SLCAUBC | <input type="checkbox"/> | <input type="checkbox"/> | <input type="checkbox"/> | <input type="checkbox"/> | | <input type="checkbox"/> | 31.0# | N/A | 493 | 526 | 542 | 493 | 542 | 540 | 586 | 611 | 638 | 659 | |
| | • Stacking on dollies is NOT recommended | | | | | | | | | | | | | | | | | | | | | |
| SLP | | | | | | | | | | | | | | | | | | | | | | |
| SLU | | | | | | | | | | | | | | | | | | | | | | |
| SLUB | | | | | | | | | | | | | | | | | | | | | | |

A **B** **C** **D** **E** **F** **G**

HOW TO ORDER

Indicate the following information on order form:

- Quantity of each item.
- Model number, including options. See "How To Build a Model Number".
- Any special service required.

Note: • The indicates that a choice is required.
 • The absence of the indicates that no choice is required.
 • Alpha-numeric characters in place of indicate that no other alternatives are available.

HOW TO BUILD A MODEL NUMBER

- A** Select basic model.
- B** Select frame color. Refer to the **Product Color Options** page in this price list.
- C** Select poly seat and back color. Refer to the **Product Color Options** page in this price list.
- D** Select casters.
 - C** - Carpet casters (black only)
 - S** - Hard floor casters (black only)
- E** Select glide option.
 - F** - Felt Glides
 - P** - Plastic glides
 - S** - Steel glides
- F** Select fire code.
 - FR** - Compliance to TB 133
 - NFR** - Compliance to TB 117-2013

G Select upholstery grade/color. Refer to ki.com/fabrics

UPHOLSTERY INFORMATION

C.O.M. Upholstery
 C.O.M. requirement for 10 chairs or less with upholstered seat or upholstered seat and back is 3/4 yard per chair of 54" wide nondirectional fabric. For orders of 11 or more with upholstered seat and back and for complete information on ordering C.O.M. see "Ordering C.O.M., C.O.V. and C.O.L." section.

OPTIONS

California TB133 Fire Safety Code
 For California Technical Bulletin 133 compliant models, add the following upcharge:

 Model=Polypropylene
 Added List Price=\$12

 Model=Upholstered Seat
 Added List Price=\$84

 Model=Upholstered Seat and Back
 Added List Price=\$119



SPECIAL SERVICES

Special Carton Marking
 With specially marked information N/C

Shipping
 Ships **assembled, FOB Green Bay, WI 54302, freight prepaid.** Freight class 125.

Specifications and prices are subject to change without prior notice.



| MODEL | Features | MODEL NUMBER | | | | | | | | Approx. Packaged Weight | Delivered Pricing Unupholstered | Delivered Pricing Fabric Grade 1 & C.O.M. | Delivered Pricing Fabric Grade 2 | Delivered Pricing Fabric Grade 3 | Delivered Pricing C.O.V. | Delivered Pricing Vinyl Group 2V | Delivered Pricing Pallas Fabric Group P0 | Delivered Pricing Pallas Fabric Group P1 | Delivered Pricing Pallas Fabric Group P2 | Delivered Pricing Pallas Fabric Group P3 | Delivered Pricing Pallas Fabric Group P4 |
|--|---------------------------|--------------|--------------------------|--------------------------|--------------------------|--------------------------|--------------------------|--------------------------|-------|-------------------------|---------------------------------|---|----------------------------------|----------------------------------|--------------------------|----------------------------------|--|--|--|--|--|
| | | Basic Model | Frame Color | Seat & Back Color | Caster Type | Glide Option | Fire Code | Upholstery Color | | | | | | | | | | | | | |
|  <p>Four-Leg Loop Arm Chair • Flex back • Stacking</p> <p>SLP SLU SLUB</p> | Polypropylene | SLLAP | <input type="checkbox"/> | <input type="checkbox"/> | <input type="checkbox"/> | <input type="checkbox"/> | <input type="checkbox"/> | <input type="checkbox"/> | 25.0# | \$ 322 | | | | | | | | | | | |
| | Upholstered Seat | SLLAU | <input type="checkbox"/> | <input type="checkbox"/> | <input type="checkbox"/> | <input type="checkbox"/> | <input type="checkbox"/> | <input type="checkbox"/> | 27.0# | N/A | 395 | 429 | 448 | 395 | 448 | 447 | 493 | 517 | 540 | 562 | |
| | Upholstered Seat/Back | SLLAUB | <input type="checkbox"/> | <input type="checkbox"/> | <input type="checkbox"/> | <input type="checkbox"/> | <input type="checkbox"/> | <input type="checkbox"/> | 27.0# | N/A | 460 | 495 | 509 | 460 | 509 | 509 | 556 | 579 | 603 | 626 | |
|  <p>Four-Leg Loop Arm Chair with Casters • Flex back • Stacking (Caution should be used if stacking to prevent casters from damaging chair and frame) • Stacking on dollies is NOT recommended</p> <p>SLP SLU SLUB</p> | Polypropylene, Casters | SLLAPC | <input type="checkbox"/> | <input type="checkbox"/> | <input type="checkbox"/> | <input type="checkbox"/> | <input type="checkbox"/> | <input type="checkbox"/> | 30.0# | \$ 367 | | | | | | | | | | | |
| | Upholstered Seat, Casters | SLLAUC | <input type="checkbox"/> | <input type="checkbox"/> | <input type="checkbox"/> | <input type="checkbox"/> | <input type="checkbox"/> | <input type="checkbox"/> | 32.0# | N/A | 443 | 479 | 495 | 443 | 495 | 493 | 536 | 562 | 591 | 608 | |
| | Uph. Seat/Back, Casters | SLLAUBC | <input type="checkbox"/> | <input type="checkbox"/> | <input type="checkbox"/> | <input type="checkbox"/> | <input type="checkbox"/> | <input type="checkbox"/> | 32.0# | N/A | 507 | 542 | 558 | 507 | 558 | 556 | 601 | 626 | 653 | 673 | |

A **B** **C** **D** **E** **F** **G**

HOW TO ORDER

Indicate the following information on order form:

- Quantity of each item.
- Model number, including options. See "How To Build a Model Number".
- Any special service required.

Note:

- The indicates that a choice is required.
- The absence of the indicates that no choice is required.
- Alpha-numeric characters in place of indicate that no other alternatives are available.

HOW TO BUILD A MODEL NUMBER

G Select upholstery grade/color. Refer to [ki.com/fabrics](https://www.ki.com/fabrics)

- A** Select basic model.
- B** Select frame color. Refer to the **Product Color Options** page in this price list.
- C** Select poly seat and back color. Refer to the **Product Color Options** page in this price list.
- D** Select casters.
 - C** - Carpet casters (black only)
 - S** - Hard floor casters (black only)
- E** Select glide option.
 - F** - Felt Glides
 - P** - Plastic glides
 - S** - Steel glides
- F** Select fire code.
 - NFR** - Compliance to TB 117-2013
 - FR** - Compliance to TB 133

UPHOLSTERY INFORMATION

C.O.M. Upholstery
C.O.M. requirement for 10 chairs or less with upholstered seat or upholstered seat and back is 3/4 yard per chair of 54" wide nondirectional fabric. For orders of 11 or more with upholstered seat and back and for complete information on ordering C.O.M. see "Ordering C.O.M., C.O.V. and C.O.L." section.

OPTIONS

California TB133 Fire Safety Code
For California Technical Bulletin 133 compliant models, add the following upcharge:

Model=Polypropylene
Added List Price=\$12

Model=Upholstered Seat
Added List Price=\$84

Model=Upholstered Seat and Back
Added List Price=\$119

SPECIAL SERVICES

Special Carton Marking

With specially marked information N/C

Shipping
Ships **assembled, FOB Green Bay, WI 54302, freight prepaid.** Freight class 125.

Specifications and prices are subject to change without prior notice.



| Features | MODEL NUMBER | | | | | | | Approx. Packaged Weight | Delivered Pricing Unupholstered | Delivered Pricing Fabric Grade 1 & C.O.M. | Delivered Pricing Fabric Grade 2 | Delivered Pricing Fabric Grade 3 | Delivered Pricing C.O.V. | Delivered Pricing Vinyl Group 2V | Delivered Pricing Pallas Fabric Group P0 | Delivered Pricing Pallas Fabric Group P1 | Delivered Pricing Pallas Fabric Group P2 | Delivered Pricing Pallas Fabric Group P3 |
|-----------------------------------|--------------|--------------------------|--------------------------|--------------------------|--------------------------|--------------------------|--------------------------|-------------------------|---------------------------------|---|----------------------------------|----------------------------------|--------------------------|----------------------------------|--|--|--|--|
| | Basic Model | Frame Color | Seat & Back Color | Glide Option | Tablet Arm Color | Fire Code | Upholstery Color | | | | | | | | | | | |
| Polypropylene, Left Hand | SLCUTAPLH | <input type="checkbox"/> | <input type="checkbox"/> | <input type="checkbox"/> | <input type="checkbox"/> | <input type="checkbox"/> | <input type="checkbox"/> | 34.0# | \$ 670 | | | | | | | | | |
| Polypropylene, Right Hand | SLCUTAPRH | <input type="checkbox"/> | <input type="checkbox"/> | <input type="checkbox"/> | <input type="checkbox"/> | <input type="checkbox"/> | <input type="checkbox"/> | 34.0# | 670 | | | | | | | | | |
| Upholstered Seat, Left Hand | SLCUTAULH | <input type="checkbox"/> | <input type="checkbox"/> | <input type="checkbox"/> | <input type="checkbox"/> | <input type="checkbox"/> | <input type="checkbox"/> | 36.5# | N/A | 746 | 780 | 796 | 746 | 796 | 792 | 873 | 863 | 889 |
| Upholstered Seat, Right Hand | SLCUTAURH | <input type="checkbox"/> | <input type="checkbox"/> | <input type="checkbox"/> | <input type="checkbox"/> | <input type="checkbox"/> | <input type="checkbox"/> | 36.5# | N/A | 746 | 780 | 796 | 746 | 796 | 792 | 873 | 863 | 889 |
| Upholstered Seat/Back, Left Hand | SLCUTAUBLH | <input type="checkbox"/> | <input type="checkbox"/> | <input type="checkbox"/> | <input type="checkbox"/> | <input type="checkbox"/> | <input type="checkbox"/> | 37.7# | N/A | 811 | 846 | 860 | 811 | 860 | 859 | 905 | 929 | 955 |
| Upholstered Seat/Back, Right Hand | SLCUTAUBRH | <input type="checkbox"/> | <input type="checkbox"/> | <input type="checkbox"/> | <input type="checkbox"/> | <input type="checkbox"/> | <input type="checkbox"/> | 37.7# | N/A | 811 | 846 | 860 | 811 | 860 | 859 | 905 | 929 | 955 |
| | | | | | | | | | | | | | | | | | | |
| | | | | | | | | | | | | | | | | | | |



SLP
SLU
SLUB

Four-Leg ChangeUp Tablet Arm Chair with Glides

- Flexing Back
- Large work surface (21"W x 13.3"D)
- Work surface flips and folds
- Work surface has 20 degrees of ingress/egress movement
- Work surface rated to 250 pounds
- Chair rated to 400 pounds

A **B** **C** **D** **E** **F** **G**

HOW TO ORDER

Indicate the following information on order form:

- Quantity of each item.
- Model number, including options. See "How To Build a Model Number".
- Any special service required.

Note:

- The indicates that a choice is required.
- The absence of the indicates that no choice is required.
- Alpha-numeric characters in place of indicate that no other alternatives are available.

HOW TO BUILD A MODEL NUMBER

A Select basic model. upcharge.

B Select frame color. Refer to the **Product Color Options** page in this price list.

C Select poly seat and back color. Refer to the **Product Color Options** page in this price list.

D Select glide option.

F - Felt Glides
P - Plastic glides
S - Steel glides

E Select tablet arm color. Refer to the **Product Color Options** page in this price list.

F Select fire code.

FR - Compliance to TB 133
NFR - Compliance to TB 117-2013
See Upholstery Information for TB133

G Select upholstery grade/color. Refer to ki.com/fabrics

UPHOLSTERY INFORMATION

C.O.M. Upholstery
C.O.M. requirement for 10 chairs or less with upholstered seat or upholstered seat and back is 3/4 yard per chair of 54" wide nondirectional fabric. For orders of 11 or more with upholstered seat and back and for complete information on ordering C.O.M. see "Ordering C.O.M., C.O.V. and C.O.L." section.

OPTIONS

California TB133 Fire Safety Code
For California Technical Bulletin 133 compliant models, add the following upcharge:

Model=Polypropylene
Added List Price=\$12

Model=Upholstered Seat
Added List Price=\$84

Model=Upholstered Seat and Back
Added List Price=\$119

SPECIAL SERVICES

Special Carton Marking
With specially marked information N/C

Shipping
Ships **assembled, FOB Green Bay, WI 54302, freight prepaid.** Freight class 125.

Specifications and prices are subject to change without prior notice.



| Features | MODEL NUMBER | | | | | | | Approx. Packaged Weight | Delivered Pricing Unupholstered | Delivered Pricing Fabric Grade 1 & C.O.M. | Delivered Pricing Fabric Grade 2 | Delivered Pricing Fabric Grade 3 | Delivered Pricing C.O.V. | Delivered Pricing Vinyl Group 2V | Delivered Pricing Pallas Fabric Group P0 | Delivered Pricing Pallas Fabric Group P1 | Delivered Pricing Pallas Fabric Group P2 | Delivered Pricing Pallas Fabric Group P3 |
|-----------------------------------|--------------|-------------|-------------------|-------------|------------------|-----------|------------------|-------------------------|---------------------------------|---|----------------------------------|----------------------------------|--------------------------|----------------------------------|--|--|--|--|
| | Basic Model | Frame Color | Seat & Back Color | Caster Type | Tablet Arm Color | Fire Code | Upholstery Color | | | | | | | | | | | |
| Polypropylene, Left Hand | SLCUTAPCLH | □□ | □□□ | □ | □□□ | □□□ | | 33.0# | \$ 715 | | | | | | | | | |
| Polypropylene, Right Hand | SLCUTAPCRH | □□ | □□□ | □ | □□□ | □□□ | | 33.0# | 715 | | | | | | | | | |
| Upholstered Seat, Left Hand | SLCUTAULH | □□ | □□□ | □ | □□□ | □□□ | □□□□□ | 35.5# | N/A | 791 | 825 | 843 | 791 | 843 | 843 | 887 | 912 | 937 |
| Upholstered Seat, Right Hand | SLCUTAUCRH | □□ | □□□ | □ | □□□ | □□□ | □□□□□ | 35.5# | N/A | 791 | 825 | 843 | 791 | 843 | 843 | 887 | 912 | 937 |
| Upholstered Seat/Back, Left Hand | SLCUTAUBCLH | □□ | □□□ | □ | □□□ | □□□ | □□□□□ | 36.7# | N/A | 856 | 889 | 907 | 856 | 907 | 906 | 952 | 976 | 1000 |
| Upholstered Seat/Back, Right Hand | SLCUTAUBCRH | □□ | □□□ | □ | □□□ | □□□ | □□□□□ | 36.7# | N/A | 856 | 889 | 907 | 856 | 907 | 906 | 952 | 976 | 1000 |

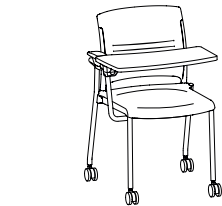

SLP
SLU
SLUB

Four-Leg ChangeUp Tablet Arm Chair with Casters

- Flexing Back
- Large work surface (21"W x 13.3"D)
- Work surface flips and folds
- Work surface has 20 degrees of ingress/egress movement
- Work surface rated to 250 pounds
- Chair rated to 400 pounds

A **B** **C** **D** **E** **F** **G**

HOW TO ORDER

Indicate the following information on order form:

- Quantity of each item.
- Model number, including options. See "How To Build a Model Number".
- Any special service required.

Note:

- The □ indicates that a choice is required.
- The absence of the □ indicates that no choice is required.
- Alpha-numeric characters in place of □ indicate that no other alternatives are available.

HOW TO BUILD A MODEL NUMBER

- A**Select basic model.
- B**Select frame color. Refer to the **Product Color Options** page in this price list.
- C**Select poly seat and back color. Refer to the **Product Color Options** page in this price list.
- D**Select casters.

| | |
|----------|-----------------------------------|
| <u>S</u> | - Hard floor casters (black only) |
| <u>C</u> | - Carpet casters |
- E**Select tablet arm color. Refer to the **Product Color Options** page in this price list.
- F**Select fire code.

| | |
|------------|-----------------------------|
| <u>NFR</u> | - Compliance to TB 117-2013 |
| <u>FR</u> | - Compliance to TB 133 |

 See Upholstery Information for TB133 upcharge.
- G**Select upholstery grade/color. Refer to ki.com/fabrics

UPHOLSTERY INFORMATION

C.O.M. Upholstery
C.O.M. requirement for 10 chairs or less with upholstered seat or upholstered seat and back is 3/4 yard per chair of 54" wide nondirectional fabric. For orders of 11 or more with upholstered seat and back and for complete information on ordering C.O.M. see "Ordering C.O.M., C.O.V. and C.O.L." section.

OPTIONS

- California TB133 Fire Safety Code**
For California Technical Bulletin 133 compliant models, add the following upcharge:
 Model=Polypropylene
Added List Price=\$12
- Model=Upholstered Seat
Added List Price=\$84
- Model=Upholstered Seat and Back
Added List Price=\$119



SPECIAL SERVICES

Special Carton Marking
With specially marked information N/C

Shipping
Ships **assembled, FOB Green Bay, WI 54302, freight prepaid.** Freight class 125.

Specifications and prices are subject to change without prior notice.



| MODEL | Features | MODEL NUMBER | | | | | | Approx. Packaged Weight | Delivered Pricing | Delivered Pricing Fabric Grade 1 & C.O.M. | Delivered Pricing Fabric Grade 2 | Delivered Pricing Fabric Grade 3 | Delivered Pricing C.O.V. | Delivered Pricing Vinyl Group 2V | Delivered Pricing Pallas Fabric Group P0 | Delivered Pricing Pallas Fabric Group P1 | Delivered Pricing Pallas Fabric Group P2 | Delivered Pricing Pallas Fabric Group P3 | Delivered Pricing Pallas Fabric Group P4 |
|---|-----------------------|--------------|--------------------------|--------------------------|--------------|--------------------------|------------------|-------------------------|-------------------|---|----------------------------------|----------------------------------|--------------------------|----------------------------------|--|--|--|--|--|
| | | Basic Model | Frame Color | Seat & Back Color | Glide Option | Fire Code | Upholstery Color | | | | | | | | | | | | |
|  Four-Leg Wallsaver Armless Chair • Flex back • Stacking • Wallsaver rear legs touch base of wall preventing chair back from contacting wall surface | Polypropylene | SLNAPWS | <input type="checkbox"/> | <input type="checkbox"/> | S | <input type="checkbox"/> | 20.0# | \$ 287 | | | | | | | | | | | |
| | Upholstered Seat | SLNAUWS | <input type="checkbox"/> | <input type="checkbox"/> | S | <input type="checkbox"/> | 23.0# | N/A | 361 | 393 | 413 | 361 | 413 | 410 | 455 | 481 | 506 | 528 | |
| | Upholstered Seat/Back | SLNAUBWS | <input type="checkbox"/> | <input type="checkbox"/> | S | <input type="checkbox"/> | 23.0# | N/A | 425 | 459 | 476 | 425 | 476 | 474 | 520 | 543 | 569 | 593 | |
| SLP | | | | | | | | | | | | | | | | | | | |
| SLU | | | | | | | | | | | | | | | | | | | |
| SLUB | | | | | | | | | | | | | | | | | | | |
|  Four-Leg Wallsaver Cantilever Arm Chair • Flex back • Stacking • Wallsaver rear legs touch base of wall preventing chair back from contacting wall surface | Polypropylene | SLCAPWS | <input type="checkbox"/> | <input type="checkbox"/> | S | <input type="checkbox"/> | 23.0# | \$ 356 | | | | | | | | | | | |
| | Upholstered Seat | SLCAUWS | <input type="checkbox"/> | <input type="checkbox"/> | S | <input type="checkbox"/> | 26.0# | N/A | 431 | 467 | 482 | 431 | 482 | 481 | 526 | 553 | 576 | 598 | |
| | Upholstered Seat/Back | SLCAUBWS | <input type="checkbox"/> | <input type="checkbox"/> | S | <input type="checkbox"/> | 26.0# | N/A | 496 | 531 | 546 | 496 | 546 | 546 | 592 | 615 | 641 | 663 | |
| SLP | | | | | | | | | | | | | | | | | | | |
| SLU | | | | | | | | | | | | | | | | | | | |
| SLUB | | | | | | | | | | | | | | | | | | | |
|  Four-Leg Wallsaver Loop Arm Chair • Flex back • Stacking • Wallsaver rear legs touch base of wall preventing chair back from contacting wall surface | Polypropylene | SLLAPWS | <input type="checkbox"/> | <input type="checkbox"/> | S | <input type="checkbox"/> | 25.0# | \$ 374 | | | | | | | | | | | |
| | Upholstered Seat | SLLAUWS | <input type="checkbox"/> | <input type="checkbox"/> | S | <input type="checkbox"/> | 27.0# | N/A | 449 | 482 | 497 | 449 | 497 | 496 | 541 | 567 | 593 | 611 | |
| | Upholstered Seat/Back | SLLAUBWS | <input type="checkbox"/> | <input type="checkbox"/> | S | <input type="checkbox"/> | 27.0# | N/A | 511 | 546 | 561 | 511 | 561 | 559 | 604 | 631 | 655 | 677 | |
| SLP | | | | | | | | | | | | | | | | | | | |
| SLU | | | | | | | | | | | | | | | | | | | |
| SLUB | | | | | | | | | | | | | | | | | | | |

A **B** **C** **D** **E** **F**

HOW TO ORDER

- Indicate the following information on order form:
1. Quantity of each item.
 2. Model number, including options. See "How To Build a Model Number".
 3. Any special service required.

Note:

- The indicates that a choice is required.
- The absence of the indicates that no choice is required.
- Alpha-numeric characters in place of indicate that no other alternatives are available.

HOW TO BUILD A MODEL NUMBER

- A** Select basic model.
- B** Select frame color. Refer to the **Product Color Options** page in this price list.
- C** Select seat and back color. Refer to the **Product Color Options** page in this price list.
- D** Select glide option.
S - Steel glides
- E** Select fire code.
FR - Compliance to TB 133
NFR - Compliance to TB 117-2013
- F** Select upholstery grade/color. Refer to ki.com/fabrics

UPHOLSTERY INFORMATION

C.O.M. Upholstery
 C.O.M. requirement for 10 chairs or less with upholstered seat or upholstered seat and back is 3/4 yard per chair of 54" wide nondirectional fabric. For orders of 11 or more with upholstered seat and back and for complete information on ordering C.O.M. see "Ordering C.O.M., C.O.V. and C.O.L." section.

OPTIONS

California TB133 Fire Safety Code
 For California Technical Bulletin 133 compliant models, add the following upcharge:

Model=Polypropylene
 Added List Price=\$12

Model=Upholstered Seat
 Added List Price=\$84

Model=Upholstered Seat and Back
 Added List Price=\$119

SPECIAL SERVICES



Special Carton Marking

With specially marked information N/C

Shipping
 Ships **assembled, FOB Green Bay, WI 54302, freight prepaid.** Freight class 125.

Specifications and prices are subject to change without prior notice.



| MODEL | Features | MODEL NUMBER | | | | | | Approx. Packaged Weight | Delivered Pricing Unupholstered | Delivered Pricing Fabric Grade 1 & C.O.M. | Delivered Pricing Fabric Grade 2 | Delivered Pricing Fabric Grade 3 | Delivered Pricing C.O.V. | Delivered Pricing Vinyl Group 2V | Delivered Pricing Pallas Fabric Group P0 | Delivered Pricing Pallas Fabric Group P1 | Delivered Pricing Pallas Fabric Group P2 | Delivered Pricing Pallas Fabric Group P3 | Delivered Pricing Pallas Fabric Group P4 | |
|---|--|-----------------------|-------------|--------------------------|--------------------------|--------------------------|--------------------------|--------------------------|---------------------------------|---|----------------------------------|----------------------------------|--------------------------|----------------------------------|--|--|--|--|--|-----|
| | | Basic Model | Frame Color | Seat & Back Color | Glide Option | Fire Code | Upholstery Color | | | | | | | | | | | | | |
|  SSP SSU SSUB | Sled Base Armless Chair • Flex back • Stacking | Polypropylene | SSNAP | <input type="checkbox"/> | <input type="checkbox"/> | <input type="checkbox"/> | <input type="checkbox"/> | 22.0# | \$ 268 | | | | | | | | | | | |
| | | Upholstered Seat | SSNAU | <input type="checkbox"/> | <input type="checkbox"/> | <input type="checkbox"/> | <input type="checkbox"/> | <input type="checkbox"/> | 25.0# | N/A | 343 | 379 | 390 | 343 | 390 | 390 | 436 | 460 | 485 | 507 |
| | | Upholstered Seat/Back | SSNAUB | <input type="checkbox"/> | <input type="checkbox"/> | <input type="checkbox"/> | <input type="checkbox"/> | <input type="checkbox"/> | 25.0# | N/A | 407 | 439 | 455 | 407 | 455 | 455 | 500 | 525 | 549 | 571 |
| | | | | | | | | | | | | | | | | | | | | |
|  SSP SSU SSUB | Sled Base Cantilever Arm Chair • Flex back • Stacking | Polypropylene | SSCAP | <input type="checkbox"/> | <input type="checkbox"/> | <input type="checkbox"/> | <input type="checkbox"/> | 24.0# | \$ 339 | | | | | | | | | | | |
| | | Upholstered Seat | SSCAU | <input type="checkbox"/> | <input type="checkbox"/> | <input type="checkbox"/> | <input type="checkbox"/> | <input type="checkbox"/> | 27.0# | N/A | 415 | 448 | 462 | 415 | 462 | 460 | 506 | 532 | 557 | 578 |
| | | Upholstered Seat/Back | SSCAUB | <input type="checkbox"/> | <input type="checkbox"/> | <input type="checkbox"/> | <input type="checkbox"/> | <input type="checkbox"/> | 27.0# | N/A | 477 | 509 | 526 | 477 | 526 | 524 | 569 | 596 | 620 | 643 |
| | | | | | | | | | | | | | | | | | | | | |
| | | A | B | C | D | E | F | | | | | | | | | | | | | |

HOW TO ORDER

Indicate the following information on order form:

- Quantity of each item.
- Model number, including options. See "How To Build a Model Number".
- Any special service required.

Note:

- The indicates that a choice is required.
- The absence of the indicates that no choice is required.
- Alpha-numeric characters in place of indicate that no other alternatives are available.

HOW TO BUILD A MODEL NUMBER

- A** Select basic model.
- B** Select frame color.
Refer to the **Product Color Options** page in this price list.
- C** Select poly seat and back color.
Refer to the **Product Color Options** page in this price list.
- D** Select glide option.
 - NG - No glides
 - GFT - Felt glides
 - GBL - Black plastic glides
 - NS - Non-skid glides
 - GSS - Stainless steel glide
- E** Select fire code.
 - NFR - Compliance to TB 117-2013
 - FR - Compliance to TB 133
- F** Select upholstery grade/color.
Refer to ki.com/fabrics

UPHOLSTERY INFORMATION

C.O.M. Upholstery
C.O.M. requirement for 10 chairs or less with upholstered seat or upholstered seat and back is 3/4 yard per chair of 54" wide nondirectional fabric. For orders of 11 or more with upholstered seat and back and for complete information on ordering C.O.M. see "Ordering C.O.M., C.O.V. and C.O.L." section.

OPTIONS

California TB133 Fire Safety Code
For California Technical Bulletin 133 compliant models, add the following upcharge:

Model=Polypropylene
Added List Price=\$12

Model=Upholstered Seat
Added List Price=\$84

Model=Upholstered Seat and Back
Added List Price=\$119

SPECIAL SERVICES

Special Carton Marking

With specially marked information N/C

Shipping
Ships assembled, FOB Green Bay, WI 54302, freight prepaid. Freight class 125.

Specifications and prices are subject to change without prior notice.



| | MODEL | Features | MODEL NUMBER | | | | | | Approx. Packaged Weight | Delivered Pricing Unupholstered | Delivered Pricing Fabric Grade 1 & C.O.M. | Delivered Pricing Fabric Grade 2 | Delivered Pricing Fabric Grade 3 | Delivered Pricing C.O.V. | Delivered Pricing Vinyl Group 2V | Delivered Pricing Pallas Fabric Group P0 | Delivered Pricing Pallas Fabric Group P1 | Delivered Pricing Pallas Fabric Group P2 | Delivered Pricing Pallas Fabric Group P3 | Delivered Pricing Pallas Fabric Group P4 | |
|--|--|--------------------------|----------------------------|--------------------------|--------------------------|--------------------------|--------------------------|--------------------------|--------------------------|---------------------------------|---|----------------------------------|----------------------------------|--------------------------|----------------------------------|--|--|--|--|--|------------------|
| | | | Basic Model | Frame Color | Seat & Back Color | Glide Option | Tablet Arm Color | Fire Code | | | | | | | | | | | | | Upholstery Color |
| | Sled Base Tablet Arm Chair | Polypropylene, Left Hand | SSTAPLH | <input type="checkbox"/> | <input type="checkbox"/> | <input type="checkbox"/> | <input type="checkbox"/> | <input type="checkbox"/> | 31.0# | \$ 507 | | | | | | | | | | | |
| | | • Flex back | Polypropylene, Right Hand | SSTAPRH | <input type="checkbox"/> | <input type="checkbox"/> | <input type="checkbox"/> | <input type="checkbox"/> | <input type="checkbox"/> | 31.0# | 507 | | | | | | | | | | |
| | | • NONSTACKING | Uph. Seat, Left Hand | SSTAULH | <input type="checkbox"/> | <input type="checkbox"/> | <input type="checkbox"/> | <input type="checkbox"/> | <input type="checkbox"/> | 33.0# | N/A | 584 | 618 | 635 | 584 | 635 | 630 | 677 | 705 | 726 | 749 |
| | | | Uph. Seat, Right Hand | SSTAURH | <input type="checkbox"/> | <input type="checkbox"/> | <input type="checkbox"/> | <input type="checkbox"/> | <input type="checkbox"/> | 33.0# | N/A | 584 | 618 | 635 | 584 | 635 | 630 | 677 | 705 | 726 | 749 |
| | | | Upholstered Seat/Back | SSTAUBLH | <input type="checkbox"/> | <input type="checkbox"/> | <input type="checkbox"/> | <input type="checkbox"/> | <input type="checkbox"/> | 33.0# | N/A | 646 | 681 | 699 | 646 | 699 | 694 | 741 | 770 | 790 | 813 |
| | | | Upholstered Seat/Back | SSTAUBRH | <input type="checkbox"/> | <input type="checkbox"/> | <input type="checkbox"/> | <input type="checkbox"/> | <input type="checkbox"/> | 33.0# | N/A | 646 | 681 | 699 | 646 | 699 | 694 | 741 | 770 | 790 | 813 |
| | SSP | | | | | | | | | | | | | | | | | | | | |
| | SSU | | | | | | | | | | | | | | | | | | | | |
| | SSUB | | | | | | | | | | | | | | | | | | | | |
| | Sled Base Oversize Tablet Arm Chair | Polypropylene, Left Hand | SSOVTPLH | <input type="checkbox"/> | <input type="checkbox"/> | <input type="checkbox"/> | <input type="checkbox"/> | <input type="checkbox"/> | 31.0# | \$ 584 | | | | | | | | | | | |
| | | • Oversized tablet | Polypropylene, Right Hand | SSOVTPRH | <input type="checkbox"/> | <input type="checkbox"/> | <input type="checkbox"/> | <input type="checkbox"/> | <input type="checkbox"/> | 31.0# | 584 | | | | | | | | | | |
| | | • Flex back | Uph. Seat, Left Hand | SSOVTAULH | <input type="checkbox"/> | <input type="checkbox"/> | <input type="checkbox"/> | <input type="checkbox"/> | <input type="checkbox"/> | 33.0# | N/A | 659 | 693 | 710 | 659 | 710 | 706 | 751 | 778 | 802 | 823 |
| | | • NONSTACKING | Uph. Seat, Right Hand | SSOVTAURH | <input type="checkbox"/> | <input type="checkbox"/> | <input type="checkbox"/> | <input type="checkbox"/> | <input type="checkbox"/> | 33.0# | N/A | 659 | 693 | 710 | 659 | 710 | 706 | 751 | 778 | 802 | 823 |
| | | | Uph. Seat/Back, Left Hand | SSOVTAUBLH | <input type="checkbox"/> | <input type="checkbox"/> | <input type="checkbox"/> | <input type="checkbox"/> | <input type="checkbox"/> | 33.0# | N/A | 723 | 755 | 774 | 723 | 774 | 771 | 815 | 843 | 865 | 887 |
| | | | Uph. Seat/Back, Right Hand | SSOVTAUBRH | <input type="checkbox"/> | <input type="checkbox"/> | <input type="checkbox"/> | <input type="checkbox"/> | <input type="checkbox"/> | 33.0# | N/A | 723 | 755 | 774 | 723 | 774 | 771 | 815 | 843 | 865 | 887 |
| | SSP | | | | | | | | | | | | | | | | | | | | |
| | SSU | | | | | | | | | | | | | | | | | | | | |
| | SSUB | | | | | | | | | | | | | | | | | | | | |

A B C D E F G

HOW TO ORDER

Indicate the following information on order form:

- Quantity of each item.
- Model number, including options. See "How To Build a Model Number".
- Any special service required.

Note:

- The indicates that a choice is required.
- The absence of the indicates that no choice is required.
- Alpha-numeric characters in place of indicate that no other alternatives are available.

HOW TO BUILD A MODEL NUMBER

A Select basic model.

B Select frame color. Refer to the **Product Color Options** page in this price list.

C Select poly seat and back color. Refer to the **Product Color Options** page in this price list.

D Select glide option.

| | |
|------------|-------------------------|
| NG | - No glides |
| GFT | - Felt glides |
| GBL | - Black plastic glides |
| NS | - Non-skid glides |
| GSS | - Stainless steel glide |

E Select tablet arm color. Refer to the **Product Color Options** page in this price list.

F Select fire code.

| | |
|------------|-----------------------------|
| NFR | - Compliance to TB 117-2013 |
| FR | - Compliance to TB 133 |

G Select upholstery grade/color. Refer to ki.com/fabrics

UPHOLSTERY INFORMATION

C.O.M. Upholstery
C.O.M. requirement for 10 chairs or less with upholstered seat or upholstered seat and back is 3/4 yard per chair of 54" wide nondirectional fabric. For orders of 11 or more with upholstered seat and back and for complete information on ordering C.O.M. see "Ordering C.O.M., C.O.V. and C.O.L." section.

OPTIONS

California TB133 Fire Safety Code
For California Technical Bulletin 133 compliant models, add the following upcharge:

Model=Polypropylene
Added List Price=\$12

Model=Upholstered Seat
Added List Price=\$84

Model=Upholstered Seat and Back
Added List Price=\$119

SPECIAL SERVICES

Special Carton Marking
With specially marked information N/C

Shipping
Ships assembled, FOB Green Bay, WI 54302, freight prepaid. Freight class 125.

Specifications and prices are subject to change without prior notice.



| Features | MODEL NUMBER | | | | | | | Approx. Packaged Weight | Delivered Pricing Unupholstered | Delivered Pricing Fabric Grade 1 & C.O.M. | Delivered Pricing Fabric Grade 2 | Delivered Pricing Fabric Grade 3 | Delivered Pricing C.O.V. | Delivered Pricing Vinyl Group 2V | Delivered Pricing Pallas Fabric Group P0 | Delivered Pricing Pallas Fabric Group P1 | Delivered Pricing Pallas Fabric Group P2 | Delivered Pricing Pallas Fabric Group P3 | |
|---|--------------|--------------------------|--------------------------|--------------------------|--------------------------|--------------------------|--------------------------|-------------------------|---------------------------------|---|----------------------------------|----------------------------------|--------------------------|----------------------------------|--|--|--|--|--|
| | Basic Model | Frame Color | Seat & Back Color | Glide Option | Tablet Arm Color | Fire Code | Upholstery Color | | | | | | | | | | | | |
| Polypropylene, Left Hand | SSCUTAPLH | <input type="checkbox"/> | <input type="checkbox"/> | <input type="checkbox"/> | <input type="checkbox"/> | <input type="checkbox"/> | | 35.0# | \$ 703 | | | | | | | | | | |
| Polypropylene, Right Hand | SSCUTAPRH | <input type="checkbox"/> | <input type="checkbox"/> | <input type="checkbox"/> | <input type="checkbox"/> | <input type="checkbox"/> | | 35.0# | 703 | | | | | | | | | | |
| Upholstered Seat, Left Hand | SSCUTAUHLH | <input type="checkbox"/> | <input type="checkbox"/> | <input type="checkbox"/> | <input type="checkbox"/> | <input type="checkbox"/> | <input type="checkbox"/> | 37.5# | N/A | 778 | 814 | 825 | 778 | 825 | 825 | 871 | 895 | 920 | |
| Upholstered Seat, Right Hand | SSCUTAUHRH | <input type="checkbox"/> | <input type="checkbox"/> | <input type="checkbox"/> | <input type="checkbox"/> | <input type="checkbox"/> | <input type="checkbox"/> | 37.5# | N/A | 778 | 814 | 825 | 778 | 825 | 825 | 871 | 895 | 920 | |
| Upholstered Seat/Back, Left Hand | SSCUTAUBLH | <input type="checkbox"/> | <input type="checkbox"/> | <input type="checkbox"/> | <input type="checkbox"/> | <input type="checkbox"/> | <input type="checkbox"/> | 38.7# | N/A | 841 | 874 | 889 | 841 | 889 | 889 | 935 | 960 | 984 | |
| Upholstered Seat/Back, Right Hand | SSCUTAUBRH | <input type="checkbox"/> | <input type="checkbox"/> | <input type="checkbox"/> | <input type="checkbox"/> | <input type="checkbox"/> | <input type="checkbox"/> | 38.7# | N/A | 841 | 874 | 889 | 841 | 889 | 889 | 935 | 960 | 984 | |
| <p>SSP</p> <p>SSU</p> <p>SSUB</p> <p>Sled Base ChangeUp Tablet Arm Chair</p> <ul style="list-style-type: none"> • Flexing Back • Large work surface (21"W x 13.3"D) • Work surface flips and folds • Work surface has 20 degrees of ingress/egress movement • Work surface rated to 250 pounds • Chair rated to 400 pounds | | | | | | | | | | | | | | | | | | | |
| | A | B | C | D | E | F | G | | | | | | | | | | | | |

HOW TO ORDER

Indicate the following information on order form:

- Quantity of each item.
- Model number, including options. See "How To Build a Model Number".
- Any special service required.

Note:

- The indicates that a choice is required.
- The absence of the indicates that no choice is required.
- Alpha-numeric characters in place of indicate that no other alternatives are available.

HOW TO BUILD A MODEL NUMBER

- A**Select basic model.
- B**Select frame color. Refer to the **Product Color Options** page in this price list.
- C**Select poly seat and back color. Refer to the **Product Color Options** page in this price list.
- D**Select glide option.
 NG - No glides
 GFT - Felt glides
 GBL - Black plastic glides
 NS - Non-skid glides
 GSS - Stainless steel glide
- E**Select tablet arm color. Refer to the **Product Color Options** page in this price list.

- F**Select fire code.
 FR - Compliance to TB 133
 NFR - Compliance to TB 117-2013
 See Upholstery Information for TB133 upcharge.
- G**Select upholstery grade/color. Refer to ki.com/fabrics

UPHOLSTERY INFORMATION

C.O.M. Upholstery
 C.O.M. requirement for 10 chairs or less with upholstered seat or upholstered seat and back is 3/4 yard per chair of 54" wide nondirectional fabric. For orders of 11 or more with upholstered seat and back and for complete information on ordering C.O.M. see "Ordering C.O.M., C.O.V. and C.O.L." section.

OPTIONS

California TB133 Fire Safety Code
 For California Technical Bulletin 133 compliant models, add the following upcharge:

Model=Polypropylene
 Added List Price=\$12

Model=Upholstered Seat
 Added List Price=\$84

Model=Upholstered Seat and Back
 Added List Price=\$119

SPECIAL SERVICES

Special Carton Marking

With specially marked information N/C

Shipping
 Ships **assembled, FOB Green Bay, WI 54302, freight prepaid**. Freight class 125.

Specifications and prices are subject to change without prior notice.

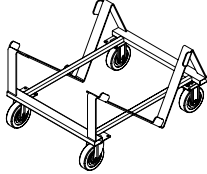
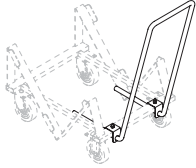

| MODEL | MODEL NUMBER | | Approx. Packaged Weight | Delivered Pricing |
|--|--------------|--|-------------------------|-------------------|
| | Basic Model | | | |
|  <p>Transport Dolly for 4-Leg and Sled Base Chairs</p> <ul style="list-style-type: none"> • Easy maneuverability with 5" casters: two fixed, two swivel • Rugged weld tubular steel frame • Black powder-coated finish | SCDA.BL | | 31.0# | \$ 518 |
| | | | | |
| | | | | |
| | | | | |
| | | | | |
| HRDPT | | | | |
|  <p>Universal Dolly Handle</p> <ul style="list-style-type: none"> • Field installable • Provides convenient handle for relocating dolly when empty or loaded • Overall dolly height with handle is 37" | UDH.BL | | 8.0# | \$ 184 |
| | | | | |
| | | | | |
| | | | | |
| | | | | |
| HRDPT | | | | |

A

HOW TO ORDER

- Indicate the following information on order form:
1. Quantity of each item.
 2. Model number, including options. See "How To Build a Model Number".
 3. Any special service required.

Note:

- The indicates that a choice is required.
- The absence of the indicates that no choice is required.
- Alpha-numeric characters in place of indicate that no other alternatives are available.

HOW TO BUILD A MODEL NUMBER

A Select basic model.

SPECIAL SERVICES

Special Carton Marking



With specially marked information N/C

Shipping

Ships **assembled, FOB Green Bay, WI 54302, freight prepaid.** Freight class 125.

Specifications and prices are subject to change without prior notice.



| MODEL | Features | Basic Model | MODEL NUMBER | | | | | | Upholstery Color | Approx. Packaged Weight | Delivered Pricing Unupholstered | Delivered Pricing Fabric Grade 1 & C.O.M. | Delivered Pricing Fabric Grade 2 | Delivered Pricing Fabric Grade 3 | Delivered Pricing C.O.V. | Delivered Pricing Vinyl Group 2V | Delivered Pricing Pallas Fabric Group P0 | Delivered Pricing Pallas Fabric Group P1 | Delivered Pricing Pallas Fabric Group P2 | Delivered Pricing Pallas Fabric Group P3 | Delivered Pricing Pallas Fabric Group P4 |
|---|-----------------------|-------------|--------------------------|--------------------------|--------------------------|--------------------------|--------------------------|--------------------------|------------------|-------------------------|---------------------------------|---|----------------------------------|----------------------------------|--------------------------|----------------------------------|--|--|--|--|--|
| | | | Seat Height | Frame Color | Seat & Back Color | Glide Option | Fire Code | | | | | | | | | | | | | | |
|  Four-Leg Armless Cafe Stool • Flex back • Stacking • Two seat heights | Polypropylene | SLSNAP | <input type="checkbox"/> | <input type="checkbox"/> | <input type="checkbox"/> | <input type="checkbox"/> | <input type="checkbox"/> | <input type="checkbox"/> | 31.0# | \$ 351 | | | | | | | | | | | |
| | Upholstered Seat | SLSNAU | <input type="checkbox"/> | <input type="checkbox"/> | <input type="checkbox"/> | <input type="checkbox"/> | <input type="checkbox"/> | <input type="checkbox"/> | 33.0# | N/A | 427 | 462 | 479 | 427 | 479 | 477 | 523 | 548 | 572 | 595 | |
| | Upholstered Seat/Back | SLSNAUB | <input type="checkbox"/> | <input type="checkbox"/> | <input type="checkbox"/> | <input type="checkbox"/> | <input type="checkbox"/> | <input type="checkbox"/> | 33.0# | N/A | 493 | 526 | 542 | 493 | 542 | 540 | 586 | 611 | 638 | 659 | |
| | | | | | | | | | | | | | | | | | | | | | |
|  Four-Leg Cantilever Arm Cafe Stool • Flex back • Stacking • Two seat heights | Polypropylene | SLSCAP | <input type="checkbox"/> | <input type="checkbox"/> | <input type="checkbox"/> | <input type="checkbox"/> | <input type="checkbox"/> | <input type="checkbox"/> | 33.0# | \$ 424 | | | | | | | | | | | |
| | Upholstered Seat | SLSCAU | <input type="checkbox"/> | <input type="checkbox"/> | <input type="checkbox"/> | <input type="checkbox"/> | <input type="checkbox"/> | <input type="checkbox"/> | 35.0# | N/A | 498 | 533 | 549 | 498 | 549 | 548 | 594 | 618 | 643 | 665 | |
| | Upholstered Seat/Back | SLSCAUB | <input type="checkbox"/> | <input type="checkbox"/> | <input type="checkbox"/> | <input type="checkbox"/> | <input type="checkbox"/> | <input type="checkbox"/> | 35.0# | N/A | 562 | 597 | 613 | 562 | 613 | 609 | 657 | 681 | 707 | 730 | |
| | | | | | | | | | | | | | | | | | | | | | |
|  Four-Leg Loop Arm Cafe Stool • Flex back • NONSTACKING • Two seat heights | Polypropylene | SLSLAP | <input type="checkbox"/> | <input type="checkbox"/> | <input type="checkbox"/> | <input type="checkbox"/> | <input type="checkbox"/> | <input type="checkbox"/> | 35.0# | \$ 438 | | | | | | | | | | | |
| | Upholstered Seat | SLSLAU | <input type="checkbox"/> | <input type="checkbox"/> | <input type="checkbox"/> | <input type="checkbox"/> | <input type="checkbox"/> | <input type="checkbox"/> | 37.0# | N/A | 513 | 549 | 564 | 513 | 564 | 562 | 607 | 635 | 659 | 679 | |
| | Upholstered Seat/Back | SLSLAUB | <input type="checkbox"/> | <input type="checkbox"/> | <input type="checkbox"/> | <input type="checkbox"/> | <input type="checkbox"/> | <input type="checkbox"/> | 37.0# | N/A | 578 | 613 | 628 | 578 | 628 | 626 | 671 | 699 | 723 | 744 | |
| | | | | | | | | | | | | | | | | | | | | | |

A B C D E F G

HOW TO ORDER

Indicate the following information on order form:

- Quantity of each item.
- Model number, including options. See “How To Build a Model Number”.
- Any special service required.

Note: • The indicates that a choice is required.

• The absence of the indicates that no choice is required.

• Alpha-numeric characters in place of indicate that no other alternatives are available.

HOW TO BUILD A MODEL NUMBER

A Select basic model.

B Select seat height.
 24 - 24” Seat Height
 30 - 30” Seat Height

C Select frame color.
 Refer to the **Product Color Options** page in this price list.

D Select poly seat and back color.
 Refer to the **Product Color Options** page in this price list.

E Select glide option.
 F - Felt Glides
 P - Plastic glides
 S - Steel glides

F Select fire code.
 FR - Compliance to TB 133
 NFR - Compliance to TB 117-2013

G Select upholstery grade/color.
 Refer to ki.com/fabrics

UPHOLSTERY INFORMATION

C.O.M. Upholstery
 C.O.M. requirement for 10 chairs or less with upholstered seat or upholstered seat and back is 3/4 yard per chair of 54” wide nondirectional fabric. For orders of 11 or more with upholstered seat and back and for complete information on ordering C.O.M. see “Ordering C.O.M., C.O.V. and C.O.L.” section.

OPTIONS

California TB133 Fire Safety Code
 For California Technical Bulletin 133 compliant models, add the following upcharge:

Model=Polypropylene
 Added List Price=\$12

Model=Upholstered Seat
 Added List Price=\$84

Model=Upholstered Seat and Back
 Added List Price=\$119

SPECIAL SERVICES

Special Carton Marking
 With specially marked information N/C

Shipping
 Ships assembled, FOB Green Bay, WI 54302, freight prepaid. Freight class 125.

Specifications and prices are subject to change without prior notice.



High Density Stacking Chair with Poly Seat (SWNA)



High Density Stacking Chair with Uph. Seat Pad (SWNAU)



High Density Stacking Chair with Tablet Arm (SWTAR)

| Features | | | |
|--------------------------------|-----------------------|--------------------|---------|
| Stackable | • | • | • |
| Poly or upholstered seat | • | • | • |
| Flex back | • | • | • |
| General Dimensions | | | |
| Seat width | 17-3/4" | 17-3/4" | 17-3/4" |
| Seat depth | 18-1/2" | 18-1/2" | 18-1/2" |
| Seat height | 18" | 18" | 18" |
| Tablet to chair back clearance | | | 15-1/4" |
| Overall Dimensions | | | |
| Width | 19-1/2" | 19-1/2" | 21-1/4" |
| Depth | 22-1/4" | 22-1/4" | 30-3/4" |
| Height | 32-1/2" | 32-1/2" | 32-1/2" |
| Stacking on Dolly | | | |
| Overall width | 22-1/2" | 22-1/2" | |
| Overall depth | 45" | 39" | |
| Quantity/height | 30 Chairs/77" High | 15 Chairs/65" High | |
| Stacking on Floor | | | |
| Width | 19-1/2" | 19-1/2" | |
| Depth | 29-1/2" | 30" | |
| Quantity/height | 6 Chairs/37-1/2" High | 5 Chairs/41" High | |



High Density Stacking Stool with Poly Seat, 24" Height (SWSNA/24)



High Density Stacking Stool with Uph Seat, 24" Height (SWSNAU/24)



High Density Stacking Stool with Poly Seat, 30" Height (SWSNA/30)



High Density Stacking Stool with Uph Seat, 30" Height (SWSNAU/30)

| Features | | | | |
|--------------------------|-----------------------|------------------------|-----------------------|--------------------|
| Stackable | • | • | • | • |
| Poly or upholstered seat | • | • | • | • |
| Flex back | • | • | • | • |
| General Dimensions | | | | |
| Seat width | 17-3/4" | 17-3/4" | 17-3/4" | 17-3/4" |
| Seat depth | 18-1/2" | 18-1/2" | 18-1/2" | 18-1/2" |
| Seat height | 24" | 24" | 30" | 30" |
| Overall Dimensions | | | | |
| Width | 19-1/2" | 19-1/2" | 19-1/2" | 19-1/2" |
| Depth | 23-1/2" | 23-1/2" | 24-1/2" | 24-1/2" |
| Height | 38-1/2" | 38-1/2" | 44-1/2" | 44-1/2" |
| Stacking on Dolly | | | | |
| Overall width | 21" | 21" | 21" | 21" |
| Overall depth | 49-1/2" | 52" | 51-1/2" | 54" |
| Quantity/height | 20 Stools/66" High | 10 Stools/54-1/2" High | 20 Stools/69" High | 10 Stools/58" High |
| Stacking on Floor | | | | |
| Width | 19-1/2" | 19-1/2" | 19-1/2" | 19-1/2" |
| Depth | 31" | 31" | 32" | 32" |
| Quantity/height | 6 Stools/43-1/2" High | 5 Stools/47" High | 6 Stools/49-1/2" High | 5 Stools/53" High |

INFORMATION

C.O.M. Testing and Production Requirements

Not all materials are suitable for upholstering this product. A 1 yd. x 54" sample must be submitted and approved prior to acceptance of an order. If the fabric is directional in pattern or weave, the direction must be indicated on the submitted sample, and additional yardage may be requested.

Test samples must be sent to:

KI
Attn: C.O.M. Specialist
1687 Westminster Drive - Gate 3
Green Bay, WI 54302

Fabric Disclaimer

Fabric will be applied as swatched by the fabric manufacturer. Fabric that is required to be applied differently than is swatched will need a Modified Product Request written specifying the direction the fabric is to be applied.

Design

Designed by Giancarlo Piretti and manufactured in the USA by Krueger International, Inc. under license from Pro-Cord S.p.A

KI Color Match Program

KI offers the additional option of color matching paint, polypropylene, or wood stain through Product Modification Requests. Contact Customer Service for details.

Whatever you imagine, whatever you require, KI's Color Match program lets you pick your color!

Color Match Process - Poly Seating Information can be found here.

INFORMATION

Warranty

Refer to KI Terms & Conditions document or visit ki.com

**Transport Dolly for Chairs
(CSD.BL)**
**Transport Dolly for Stools
(WSSD.BL)**

| Overall Dimensions | | |
|--------------------|---------|---------|
| Width | 22-3/8" | 21" |
| Depth | 25-5/8" | 26-1/2" |

TECHNICAL SPECIFICATIONS

Seat

Injection-molded polypropylene seat.

Backrest

Injection molded polypropylene with integral steel cantilever springs. The combination of the slotted polypropylene back and the spring steel provides a supportive flexing back. Springs are nominal 4.5 mm diameter chrome silicon valve spring wire. Top of backrest has an integral handle for ease of lifting and stacking.

Chair & Stool Frames & Finishes

7/16" solid steel rod, all joints welded. Finished in bright nickel-chrome or with electrostatically-applied epoxy powder-coat paint.

Optional Upholstered Seat

Molded urethane foam (soy based) is attached to an injection-molded polypropylene seat board, the upholstered using a draw-string process. The assembled seat pad is attached to the seat by means of hidden fasteners. Note: upholstered seat is required with translucent poly backs.

Transport Dolly

Tubular and plate steel welded together. 5" casters: two fixed, two swivel. Powder-coated finish.

Tablet Arm

7/16" solid steel rod frame, hinged tablet for easy access. Tablet has plywood core; high-pressure laminate surface. Round tablet edge with clear lacquer finish. Bright chrome frame only. Chairs are nonstacking when attached, not available for use with powder-coated frame chairs. Tablet fits chairs only; does not fit stools. Tablet flips up for easy access. Ganging with tablet is not recommended.

STATEMENT OF LINE

All models are available in polypropylene seat/backrest or upholstered seat/polypropylene backrest.

Strive High-Density Sled Base Stack Chair

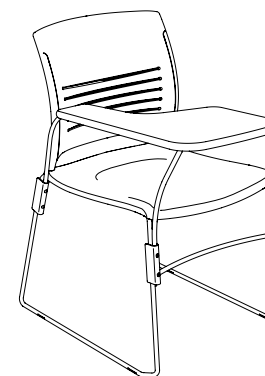
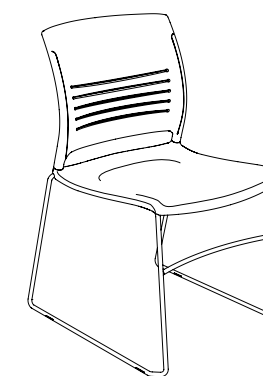

SWNA with SWTAR

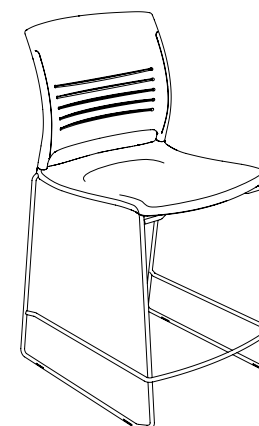
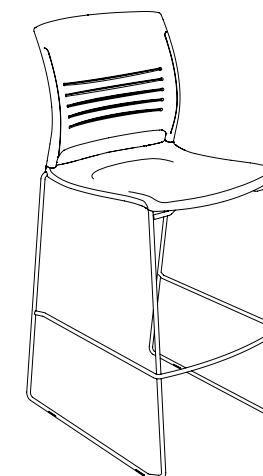
SWNA

Strive High-Density Sled Base Stack Stools

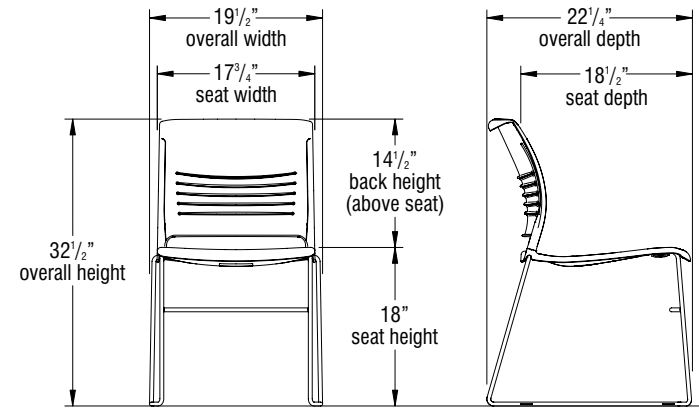

SWSNAP24

SWSNAP30



Strive High-Density Sled Base Chair -
Polypropylene Seat & Backrest

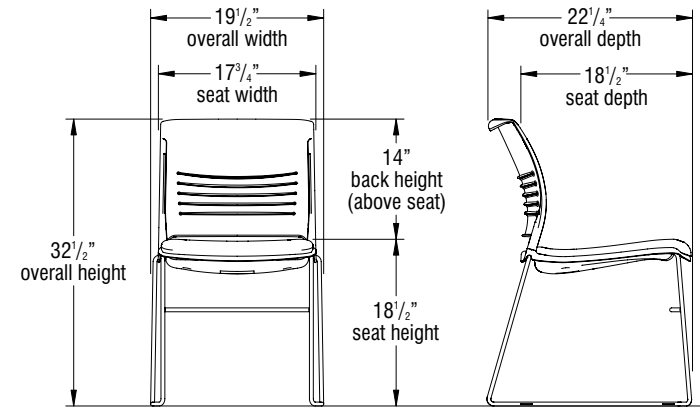

Strive High-Density Sled Base Chair -
Upholstered Seat & Polypropylene Backrest



Strive High-Density 24" Sled Base Stool -
Polypropylene Seat & Backrest

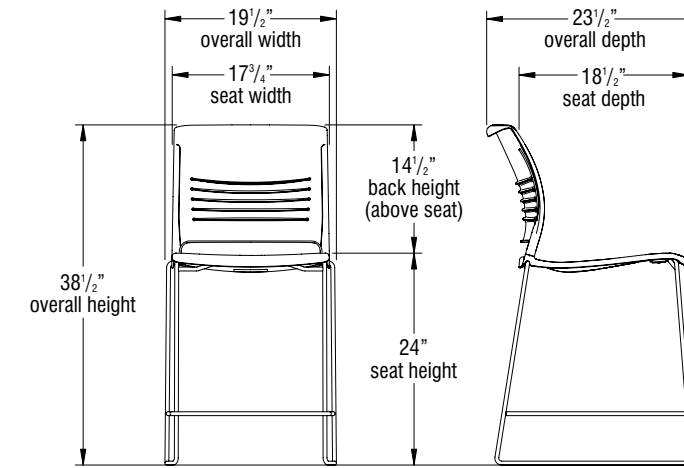

Strive High-Density 24" Sled Base Stool -
Upholstered Seat & Polypropylene Backrest

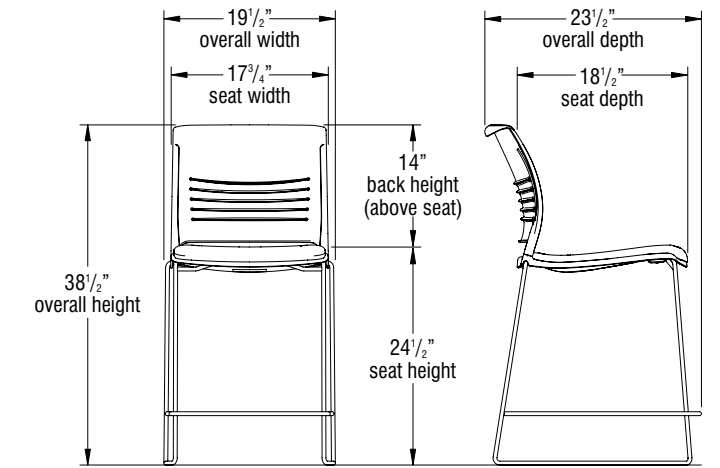

Strive High-Density Chair with Tablet Arm

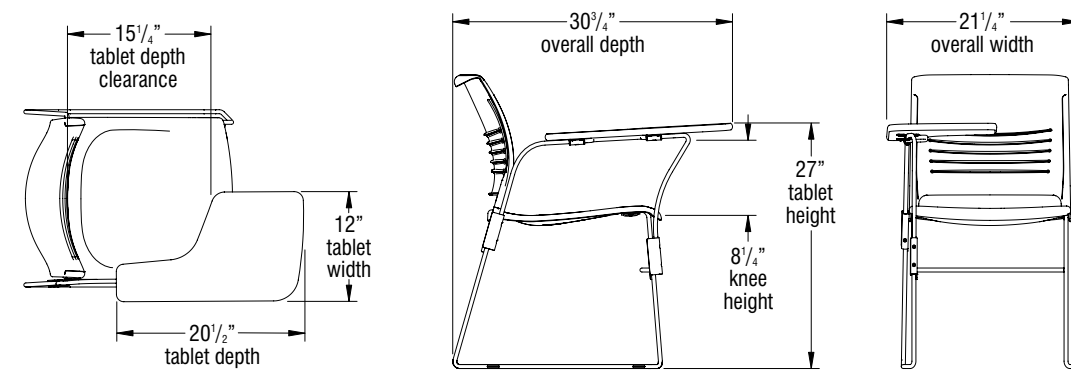

Strive High-Density 30" Sled Base Stool -
Polypropylene Seat & Backrest

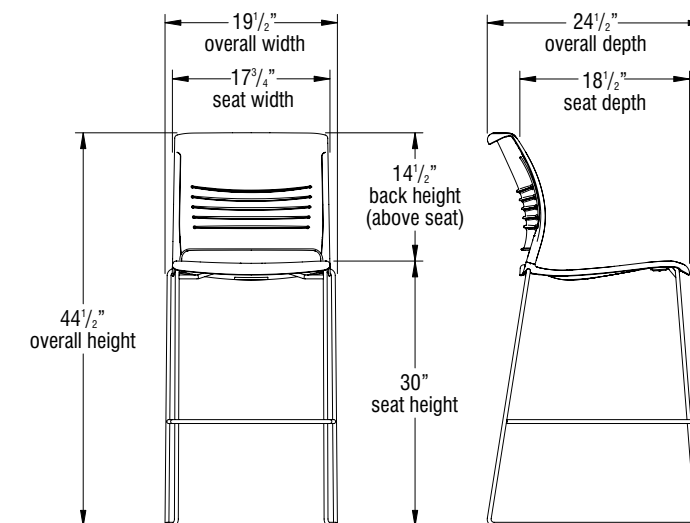

Strive High-Density 30" Sled Base Stool -
Upholstered Seat & Polypropylene Backrest

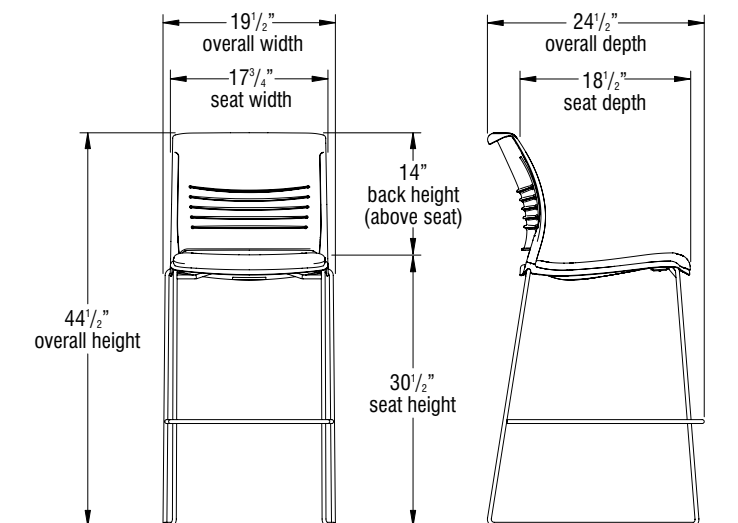

Frame Color

| |
|---------------------------|
| Black |
| Blue Grey |
| Bronze Metallic |
| Cayenne |
| Champagne Metallic |
| Chrome |
| Cool Grey |
| Cottonwood |
| Earthen Clay |
| Espresso Metallic |
| Everglade Shade |
| Flannel |
| Glitz Metallic |
| Hazy Jade |
| Honey Bee |
| Light Tone |
| Mardi Gras |
| Misty Brown |
| Nemo |
| Nordic |
| Poppy Red |
| Purple Haze |
| Rubber Ducky |
| Sand |
| Sky Blue |
| Starlight Silver Metallic |
| Surf's Up |
| Twilight Shadow |
| Ultra Blue |
| Warm Grey |
| Zesty Lime |

Armcaps and glides match the frame color with the following exceptions:

-When frame color is chrome or metallic, the armcaps and glides will match poly color.

-When back is diamond translucent, armcaps are light tone.

-When back is pewter translucent, armcaps are flannel.

Casters for four-leg chairs are always black.

Seat and Back Color - Polypropylene
Non Flame-Retardant

| | |
|----|---|
| BL | Black |
| GR | Black |
| ZM | Blue Grey |
| CY | Cayenne |
| CM | Cool Grey |
| CH | Cottonwood |
| CG | Diamond Translucent |
| CO | Earthen Clay |
| EY | Everglade Shade |
| EX | Flannel |
| EV | Hazy Jade |
| FN | Honey Bee |
| GZ | Light Tone |
| HJ | Mardi Gras |
| HY | Misty Brown |
| LG | Nemo |
| MG | Nordic |
| MY | Pewter Translucent |
| NE | Poppy Red |
| ND | Purple Haze |
| PR | Rubber Ducky |
| PH | Sand |
| RK | Sky Blue |
| SA | Surf's Up |
| SK | Twilight Shadow |
| SX | Ultra Blue |
| SP | Warm Grey |
| TI | Zesty Lime |
| UB | |
| WG | Diamond Translucent and Pewter Translucent are only available on upholstered seat models. |
| ZL | |

Seat and Back Color - Polypropylene
Flame-Retardant

| | |
|-----|-------|
| PBL | Black |
|-----|-------|

The above seating product can be manufactured using the appropriate flame-retardant materials for compliance to California Technical Bulletin 133.

*NOTE: When FR upholstery is selected, FR poly (black only) must be selected. NFR poly is not available with FR upholstery.

Tablet Arm Color - Laminate

| | |
|-----|--------------------|
| PBL | Belair |
| PGR | Biltmore Cherry |
| PCY | Black |
| PCG | Brighton Walnut |
| PCO | Canyon Zephyr |
| PDT | Castle Oak |
| PEY | Casual Linen |
| PEV | Cherry Storm |
| PFN | Classic Linen |
| PHJ | Cloud Zephyr |
| PHY | Cocobala |
| PLG | Crisp Linen |
| PMG | Desert Zephyr |
| PMY | Dove Grey |
| PNE | Fired Steel |
| PND | Flax Linen |
| PPT | Florence Walnut |
| PPR | Forged Steel |
| PPH | Friston Ash |
| PRK | Frosty White |
| PSA | Graphite Nebula |
| PSK | Grey |
| PSP | High Rise |
| PTI | Hollyberry |
| PUB | Irish Linen |
| PWG | Island |
| PZL | Italian Silver Ash |
| | Kensington Maple |
| | Lapis Blue |
| | Markerboard White |
| | Misted Zephyr |
| | Monticello Maple |
| | Nickel Evolv |
| | North Sea |
| | Ocean |
| | Pearl Bisque |
| | Pearl Silver |
| | Pressed Linen |
| | River Cherry |
| | Rugged Linen |
| | Satin Stainless |
| | Shadow Zephyr |
| | Silicon evolv |
| | Sterling Ash |
| | Tailored Linen |
| | Titanium evolv |
| | White Nebula |
| | White Sand |
| | Windsor Mahogany |

| |
|-----|
| LBQ |
| LBT |
| LBK |
| LBW |
| LCA |
| LCO |
| LCU |
| LCX |
| LCI |
| LCL |
| LCC |
| LRI |
| LDZ |
| LDG |
| LIL |
| LXF |
| LFC |
| LOL |
| LFH |
| LFW |
| LGN |
| LGE |
| LHE |
| LHY |
| LIH |
| LID |
| LIT |
| LKM |
| LLB |
| LMK |
| LMR |
| LMT |
| LNV |
| LNA |
| LON |
| LPB |
| LPS |
| LPR |
| LRY |
| LRG |
| LSS |
| LSR |
| LSV |
| LAZ |
| LTL |
| LTV |
| LWL |
| LWN |
| LWY |

Finish Cards

View color swatches for items listed within this document.

Paints
Plastics/Poly
Wood/Veneer
Laminates
Molded Edges
Edge Styles
Hard Plastics
Glass

Certain options referenced may not be available on GSA Schedule.

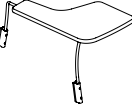
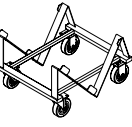

| MODEL | Features | MODEL NUMBER | | | | | | | Approx. Packaged Weight | Delivered Pricing Unupholstered | Delivered Pricing Fabric Grade 1 & C.O.M. | Delivered Pricing Fabric Grade 2 | Delivered Pricing Fabric Grade 3 | Delivered Pricing Vinyl Group 2V | Delivered Pricing Pallas Fabric Group P0 | Delivered Pricing Pallas Fabric Group P1 | Delivered Pricing Pallas Fabric Group P2 | Delivered Pricing Pallas Fabric Group P3 | Delivered Pricing Pallas Fabric Group P4 | |
|---|------------------|--------------|--------------------------|--------------------------|--------------------------|--------------------------|--------------------------|--------------------------|-------------------------|---------------------------------|---|----------------------------------|----------------------------------|----------------------------------|--|--|--|--|--|-----|
| | | Basic Model | Frame Color | Seat & Back Color | Upholstery Color | Glide Option | Fire Code | Tablet Arm Color | | | | | | | | | | | | |
|  SWSCP SWSCU Armless Chair • Flex back | Polypropylene | SWNA | <input type="checkbox"/> | <input type="checkbox"/> | | <input type="checkbox"/> | <input type="checkbox"/> | | 17.0# | \$ 231 | | | | | | | | | | |
| | Upholstered Seat | SWNAU | <input type="checkbox"/> | <input type="checkbox"/> | <input type="checkbox"/> | <input type="checkbox"/> | <input type="checkbox"/> | <input type="checkbox"/> | | 17.0# | N/A | 307 | 343 | 356 | 356 | 355 | 399 | 426 | 452 | 474 |
|  SWTA Standard Flip-Up Tablet Arm • NONSTACKING • 12" wide x 20-1/2" deep • Field installable • For use only on chrome framed chairs | Left Hand | SWTAL | | | | | <input type="checkbox"/> | <input type="checkbox"/> | 7.0# | \$ 226 | | | | | | | | | | |
| | Right Hand | SWTAR | | | | | <input type="checkbox"/> | <input type="checkbox"/> | 7.0# | 226 | | | | | | | | | | |
|  HRDPT Transport Dolly - Chair • Accommodates up to 30 poly chairs or 15 upholstered chairs • Easy maneuverability with 5" casters: two fixed, two swivel • Black powder-coated finish | | CSD.BL | | | | | | | 30.0# | \$ 512 | | | | | | | | | | |
| | | UDH.BL | | | | | | | 8.0# | \$ 184 | | | | | | | | | | |

A **B** **C** **D** **E** **F** **G**

HOW TO ORDER

- Indicate the following information on order form:
- Quantity of each item.
 - Model number, including options. See "How To Build a Model Number".
 - Any special service required.

Note:

- The indicates that a choice is required.
- The absence of the indicates that no choice is required.
- Alpha-numeric characters in place of indicate that no other alternatives are available.

HOW TO BUILD A MODEL NUMBER

- A** Select basic model.
- B** Select frame color. Refer to the **Product Color Options** page in this price list.
- C** Select seat and back color. Refer to the **Product Color Options** page in this price list.
- D** Select upholstery grade/color. Refer to ki.com/fabrics
- E** Select glide option.
- F** Select fire code.
- G** Select tablet arm color. Refer to the **Product Color Options** page in this price list.

UPHOLSTERY INFORMATION

C.O.M. Upholstery
 C.O.M. requirement for 10 chairs or less with upholstered seat or upholstered seat and back is 3/4 yard per chair of 54" wide nondirectional fabric. For orders of 11 or more with upholstered seat and back and for complete information on ordering C.O.M. see "Ordering C.O.M., C.O.V. and C.O.L." section.

OPTIONS

California TB133 Fire Safety Code
 For California Technical Bulletin 133 compliant models, add the following upcharge:

Model=Polypropylene
 Added List Price=\$12

Model=Upholstered Seat
 Added List Price=\$84

SPECIAL SERVICES

Special Carton Marking
 With specially marked information N/C

Shipping
 Ships **assembled, FOB Green Bay, WI 54302, freight prepaid.** Freight class 125.

Specifications and prices are subject to change without prior notice.

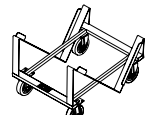
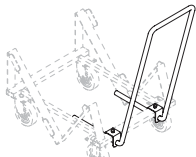

| MODEL | Features | MODEL NUMBER | | | | | | | Approx. Packaged Weight | Delivered Pricing Unupholstered | Delivered Pricing Fabric Grade 1 & C.O.M. | Delivered Pricing Fabric Grade 2 | Delivered Pricing Fabric Grade 3 | Delivered Pricing Vinyl Group 2V | Delivered Pricing Pallas Fabric Group P0 | Delivered Pricing Pallas Fabric Group P1 | Delivered Pricing Pallas Fabric Group P2 | Delivered Pricing Pallas Fabric Group P3 | Delivered Pricing Pallas Fabric Group P4 |
|--|------------------|--------------|--------------------------|--------------------------|--------------------------|--------------------------|--------------------------|--------------------------|-------------------------|---------------------------------|---|----------------------------------|----------------------------------|----------------------------------|--|--|--|--|--|
| | | Basic Model | Seat Height | Frame Color | Seat & Back Color | Upholstery Color | Glide Option | Fire Code | | | | | | | | | | | |
|  SWSSP SWSSU Armless Stool • Flex Back • Two seat heights (24" & 30") • 24" H stool specified for use with 36" H tables • 30" H stool specified for use with 42" H tables | Polypropylene | SWSNA | <input type="checkbox"/> | <input type="checkbox"/> | <input type="checkbox"/> | | <input type="checkbox"/> | <input type="checkbox"/> | 21.0# | \$ 346 | | | | | | | | | |
| | Upholstered Seat | SWSNAU | <input type="checkbox"/> | <input type="checkbox"/> | <input type="checkbox"/> | <input type="checkbox"/> | <input type="checkbox"/> | <input type="checkbox"/> | 21.0# | N/A | 422 | 458 | 471 | 471 | 470 | 513 | 541 | 567 | 589 |
|  HRDPT Transport Dolly - Stool • Accommodates up to 20 poly stools or 10 upholstered stools • Easy maneuverability with 5" casters: two fixed, two swivel • Black powder-coated finish | | WSSD.BL | | | | | | | 31.0# | \$ 518 | | | | | | | | | |
| | | | | | | | | | | | | | | | | | | | |
|  HRDPT Universal Dolly Handle • Field installable • Provides convenient handle for relocating dolly when empty or loaded • Overall dolly height with handle is 37" | | UDH.BL | | | | | | | 8.0# | \$ 184 | | | | | | | | | |
| | | | | | | | | | | | | | | | | | | | |

A **B** **C** **D** **E** **F** **G**

HOW TO ORDER

- Indicate the following information on order form:
- Quantity of each item.
 - Model number, including options. See "How To Build a Model Number".
 - Any special service required.

Note:

- The indicates that a choice is required.
- The absence of the indicates that no choice is required.
- Alpha-numeric characters in place of indicate that no other alternatives are available.

HOW TO BUILD A MODEL NUMBER

- A** Select basic model.
- B** Select seat height.

| | |
|-----------|-------------------|
| 24 | - 24" Seat Height |
| 30 | - 30" Seat Height |
- C** Select frame color.
Refer to the **Product Color Options** page in this price list.
- D** Select seat and back color.
Refer to the **Product Color Options** page in this price list.
- E** Select upholstery grade/color.
Refer to ki.com/fabrics
- F** Select glide option.

| | |
|-----------|---|
| G | - Ganging polycarbonate glides; add \$5 |
| GS | - Ganging steel glides; add \$5 |
| NG | - No glides |
| H | - Polycarbonate glides; add \$5 |

- NS** - PVC non-skid glides; add \$5
- S** - Stainless steel glides; add \$5
- G** Select fire code.

| | |
|------------|-----------------------------|
| FR | - Compliance to TB 133 |
| NFR | - Compliance to TB 117-2013 |

UPHOLSTERY INFORMATION

C.O.M. Upholstery
 C.O.M. requirement for 10 chairs or less with upholstered seat or upholstered seat and back is 3/4 yard per chair of 54" wide nondirectional fabric. For orders of 11 or more with upholstered seat and back and for complete information on ordering C.O.M. see "Ordering C.O.M., C.O.V. and C.O.L." section.

OPTIONS

California TB133 Fire Safety Code
 For California Technical Bulletin 133 compliant models, add the following upcharge:

Model=Polypropylene
 Added List Price=\$12

Model=Upholstered Seat
 Added List Price=\$84

SPECIAL SERVICES

Special Carton Marking
 With specially marked information N/C

Shipping
 Ships **assembled, FOB Green Bay, WI 54302, freight prepaid.** Freight class 125.

Specifications and prices are subject to change without prior notice.



**Cantilever Armchair
(SNCAU)**



**Armless Chair
(SNNAP)**



Tablet Arm Chair (SNTAURH)

Oversize Tablet Arm Chair

| Features | | | | |
|---|---------|---------|---------|---------|
| Poly or upholstered seat | • | • | • | • |
| Flex back | • | • | • | • |
| Flip-up seat | • | • | • | • |
| Integral handle | • | • | • | • |
| Nesting | • | • | • | • |
| General Dimensions | | | | |
| Seat width | 17" | 17" | 17" | 17" |
| Seat depth | 18" | 18" | 18" | 18" |
| Seat height (upholstered add 1") | 16-1/2" | 16-1/2" | 16-1/2" | 16-1/2" |
| Tablet to chair back clearance | | | 14" | 14" |
| Overall Dimensions | | | | |
| Width | 23" | 23" | 24" | 24" |
| Depth | 22-3/4" | 22-3/4" | 29" | 32" |
| Height | 33-3/4" | 33-3/4" | 33-3/4" | 33-3/4" |
| Top of arm to floor | 25-1/2" | | 28-1/4" | 28-1/4" |
| Nesting (two chairs) (upholstered add 1") | 28-1/2" | 28-1/2" | 34-3/4" | 37-3/4" |
| Nesting - For each additional chair, add 5-3/4" (upholstered add 1") | | | | |

TECHNICAL SPECIFICATIONS

Seat and Backrest

Seat is two-piece construction of injection-molded polypropylene, reinforced with internal steel channels, and assembled using hidden fasteners. The seat is available in a poly version or upholstered. For the upholstered version, molded urethane foam (1" depth) is applied to the seat board. Fabric is then upholstered over the foam using a drawstring process. Note: upholstered seat is required with translucent poly backs.

Backrest is injection-molded polypropylene with integral steel cantilever springs. The combination of the slotted polypropylene back and the spring steel provides a supportive flexing back. Springs are nominal 4.5 mm diameter chrome silicon valve spring wire. Backrest is available poly only. Backrest has an integral, molded "handle".

Seat flips up to allow chairs to nest for storage and transport.

Seat assembly and backrest are field replaceable.

Frame

The legs are 1", 13-gauge high-strength steel tubing. All frame joints are welded.

Frame Finishes

Frames are finished in either baked-on electrostatically-applied 30 gloss epoxy powder-coat paint, or bright nickel chrome plating.

Casters/Glides

Double wheels (60 mm) of high-impact thermoplastic. High-impact plastic frame. Casters are always black. Carpet or hard floor. Bell glide (2" high) made of high-impact plastic also available, black only.

Arms

Optional fixed-position T-arms are available. Arm supports are a continuation of the frame crossmember tube, with injection-molded polypropylene arm caps attached by screws. The armcaps are injection-molded glass filled polypropylene matching the frame finish (when frame finish is Chrome, hammertones, or Starlight Silver metallic, armcaps match the seat and back color; when back is Diamond translucent, armcaps are Light Tone; when back is Pewter translucent, armcaps are Flannel).

Tablet Arm

An optional tablet arm is available on either the right or left-hand side. When so equipped, the tablet arm support structure is a continuation of the frame crossmember tube. A formed steel hinge is welded to the top of the support structure and secured with screws to the underside of the writing surface. Writing surface for standard tablet is 9 1/2" x 20 3/4" x 12 1/2" and oversize tablet is 15 1/2" x 22 1/2" x 14" plywood core of 5/8" thick, 1 1-ply hardwood surfaced with .030" high-pressure laminate top and plain backer undersurface. Tablet arm flips up for easy access. Edges are lacquered and sealed.

INFORMATION

C.O.M Testing and Production Requirements

Not all materials are suitable for upholstering this product. A 3/4 yd. x 54" sample must be submitted and approved prior to acceptance of an order. If the fabric is directional in pattern or weave, the direction must be indicated on the submitted sample, and additional yardage may be requested.

Test samples must be sent to:

KI
Attn: C.O.M. Specialist
1687 Westminster Drive - Gate 3
Green Bay, WI 54302

Fabric Disclaimer

Fabric will be applied as swatched by the fabric manufacturer. Fabric that is required to be applied differently than is swatched will need a Modified Product Request written specifying the direction the fabric is to be applied.

KI Color Match Program

KI offers the additional option of color matching paint, polypropylene, or wood stain through Product Modification Requests. Contact Customer Service for details.

Whatever you imagine, whatever you require, KI's Color Match program lets you pick your color!

Color Match Process - Poly Seating Information can be found here.

INFORMATION

Warranty

Refer to KI Terms & Conditions document or visit ki.com

DIMENSIONS

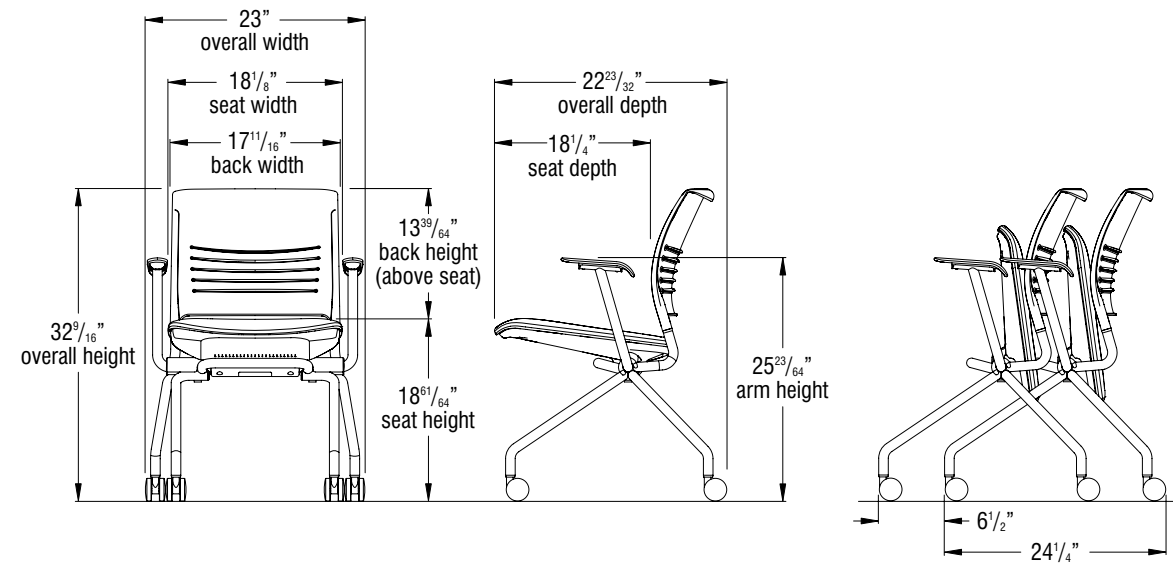

Nesting Footprint Calculation: Overall Length of a Row = 24.25" (1 chair) + 6.5" (additional chairs)

- Examples: 2 Chairs: 24.25" (1 chair) + 6.5" (1 chair) = 30.75"
- 16 Chairs: 24.25" (1 chair) + 6.5" (15 chairs) = 121.75"

STATEMENT OF LINE

Strive Nesting Armless Chair

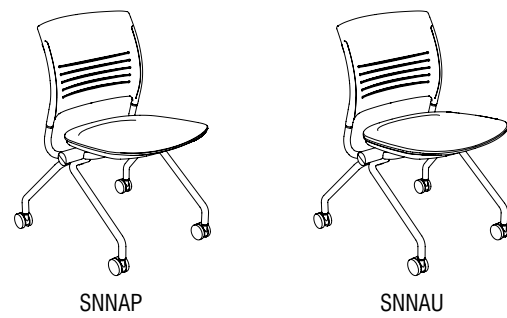

Strive Nesting Cantilever Armchair

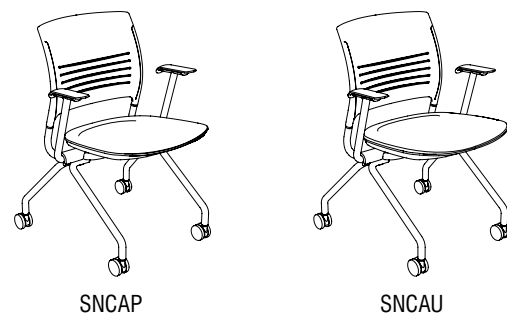

STATEMENT OF LINE

Strive Nesting Tablet Arm Chair

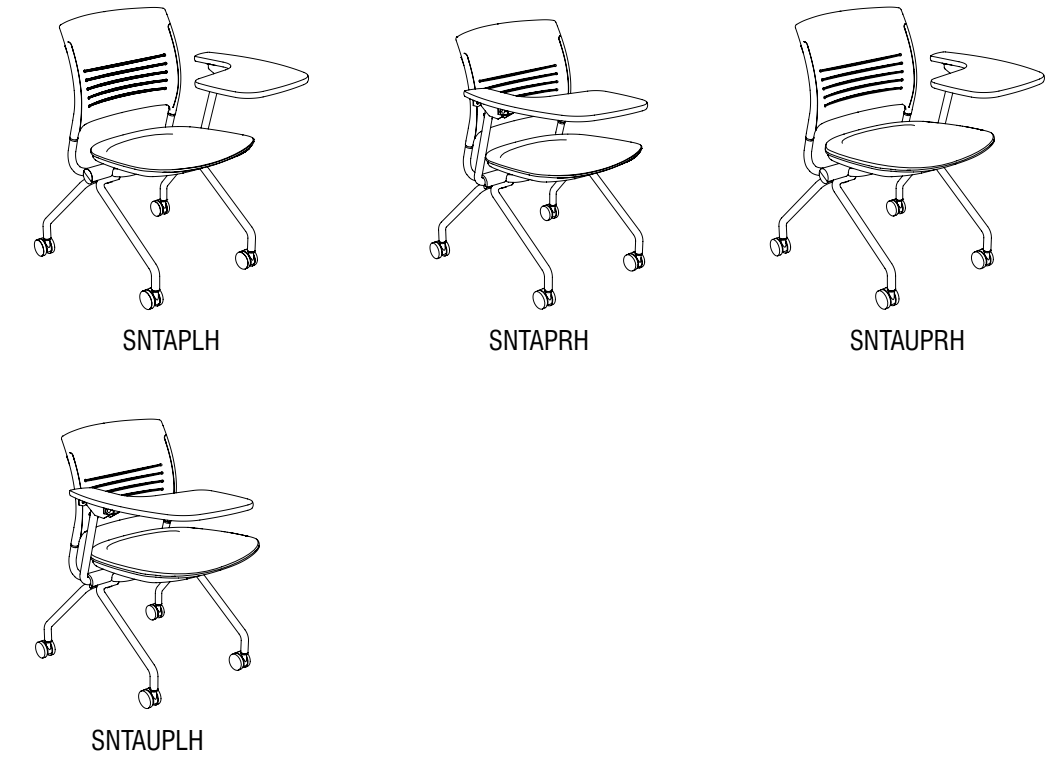

Strive Nesting Oversized Tablet Arm Chair

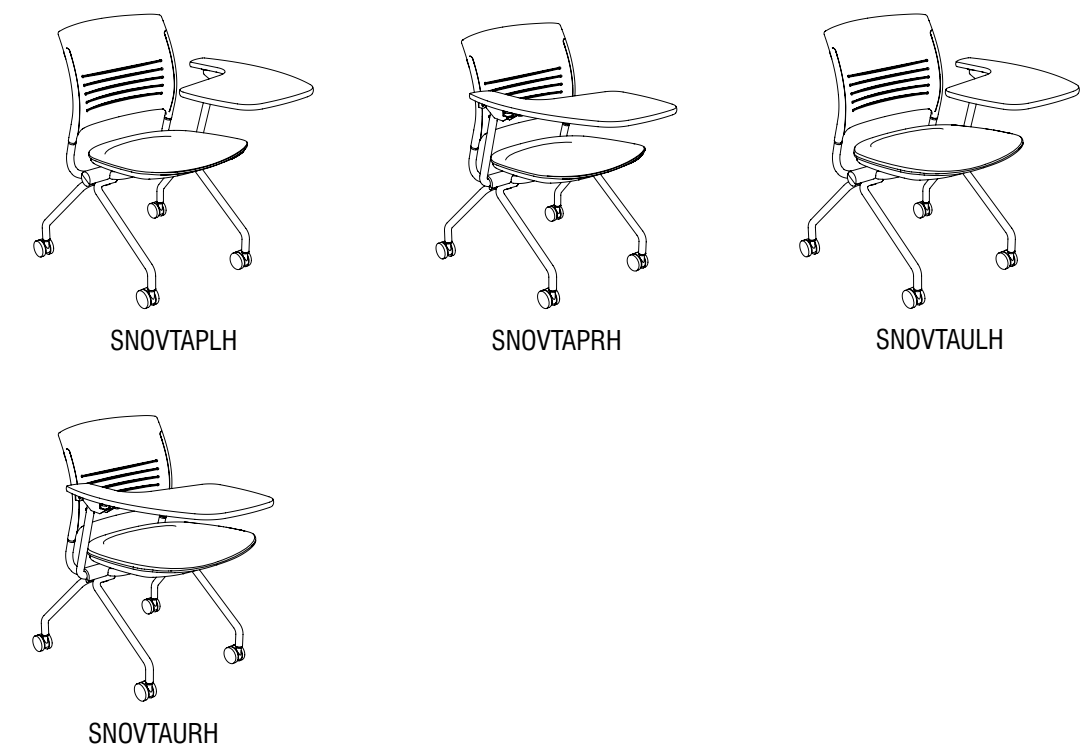

Frame Color

| |
|---------------------------|
| Black |
| Blue Grey |
| Bronze Metallic |
| Cayenne |
| Champagne Metallic |
| Chrome |
| Cool Grey |
| Cottonwood |
| Earthen Clay |
| Espresso Metallic |
| Everglade Shade |
| Flannel |
| Glitz Metallic |
| Hazy Jade |
| Honey Bee |
| Light Tone |
| Mardi Gras |
| Misty Brown |
| Nemo |
| Nordic |
| Poppy Red |
| Purple Haze |
| Rubber Ducky |
| Sand |
| Sky Blue |
| Starlight Silver Metallic |
| Surf's Up |
| Twilight Shadow |
| Ultra Blue |
| Warm Grey |
| Zesty Lime |

Armcaps and glides match the frame color with the following exceptions:
 -When frame color is chrome or metallic, the armcaps and glides will match poly color.
 -When back is diamond translucent, armcaps are light tone.
 -When back is pewter translucent, armcaps are flannel.

Casters for four-leg chairs are always black.

Seat and Back Color - Polypropylene**Non Flame-Retardant**

| | |
|----|---|
| BL | Black |
| GR | Black |
| ZM | Blue Grey |
| CY | Cayenne |
| CM | Cool Grey |
| CH | Cottonwood |
| CG | Diamond Translucent |
| CO | Earthen Clay |
| EY | Everglade Shade |
| EX | Flannel |
| EV | Hazy Jade |
| FN | Honey Bee |
| GZ | Light Tone |
| HJ | Mardi Gras |
| HY | Misty Brown |
| LG | Nemo |
| MG | Nordic |
| MY | Pewter Translucent |
| NE | Poppy Red |
| ND | Purple Haze |
| PR | Rubber Ducky |
| PH | Sand |
| RK | Sky Blue |
| SA | Surf's Up |
| SK | Twilight Shadow |
| SX | Ultra Blue |
| SP | Warm Grey |
| TI | Zesty Lime |
| UB | |
| WG | Diamond Translucent and Pewter Translucent are only available on upholstered seat models. |
| ZL | |

Seat and Back Color - Polypropylene**Flame-Retardant**

| | |
|-----|-------|
| PBL | Black |
|-----|-------|

The above seating product can be manufactured using the appropriate flame-retardant materials for compliance to California Technical Bulletin 133.

*NOTE: When FR upholstery is selected, FR poly (black only) must be selected. NFR poly is not available with FR upholstery.

Tablet Arm Color - Laminate

| | |
|-----|--------------------|
| PBL | Belair |
| PGR | Biltmore Cherry |
| PCY | Black |
| PCG | Brighton Walnut |
| PCO | Canyon Zephyr |
| PDT | Castle Oak |
| PEY | Casual Linen |
| PEV | Cherry Storm |
| PFN | Classic Linen |
| PHJ | Cloud Zephyr |
| PHY | Cocobala |
| PLG | Crisp Linen |
| PMG | Desert Zephyr |
| PMY | Dove Grey |
| PNE | Fired Steel |
| PND | Flax Linen |
| PPT | Florence Walnut |
| PPR | Forged Steel |
| PPH | Friston Ash |
| PRK | Frosty White |
| PSA | Graphite Nebula |
| PSK | Grey |
| PSP | High Rise |
| PTI | Hollyberry |
| PUB | Irish Linen |
| PWG | Island |
| PZL | Italian Silver Ash |
| | Kensington Maple |
| | Lapis Blue |
| | Markerboard White |
| | Misted Zephyr |
| | Monticello Maple |
| | Nickel Evolv |
| | North Sea |
| | Ocean |
| | Pearl Bisque |
| | Pearl Silver |
| | Pressed Linen |
| | River Cherry |
| | Rugged Linen |
| | Satin Stainless |
| | Shadow Zephyr |
| | Silicon evolv |
| | Sterling Ash |
| | Tailored Linen |
| | Titanium evolv |
| | White Nebula |
| | White Sand |
| | Windsor Mahogany |

| |
|-----|
| LBQ |
| LBT |
| LBK |
| LBW |
| LCA |
| LCO |
| LCU |
| LCX |
| LCI |
| LCL |
| LCC |
| LRI |
| LDZ |
| LDG |
| LIL |
| LXF |
| LFC |
| LOL |
| LFH |
| LFW |
| LGN |
| LGE |
| LHE |
| LHY |
| LIH |
| LID |
| LIT |
| LKM |
| LLB |
| LMK |
| LMR |
| LMT |
| LNV |
| LNA |
| LON |
| LPB |
| LPS |
| LPR |
| LRY |
| LRG |
| LSS |
| LSR |
| LSV |
| LAZ |
| LTL |
| LTV |
| LWL |
| LWN |
| LWY |





Finish Cards

View color swatches for items listed within this document.

Paints**Plastics/Poly****Wood/Veneer****Laminates****Molded Edges****Edge Styles****Hard Plastics****Glass**

Certain options referenced may not be available on GSA Schedule.



| MODEL | MODEL NUMBER | | | | | | Approx. Packaged Weight | Delivered Pricing | Delivered Pricing Fabric Grade 1 & C.O.M. | Delivered Pricing Fabric Grade 2 | Delivered Pricing Fabric Grade 3 | Delivered Pricing C.O.V. | Delivered Pricing Vinyl Group 2V | Delivered Pricing Pallas Fabric Group P0 | Delivered Pricing Pallas Fabric Group P1 | Delivered Pricing Pallas Fabric Group P2 | Delivered Pricing Pallas Fabric Group P3 | Delivered Pricing Pallas Fabric Group P4 |
|---|--------------|--------------------------|--------------------------|--------------------------|--------------------------|--------------------------|-------------------------|-------------------|---|----------------------------------|----------------------------------|--------------------------|----------------------------------|--|--|--|--|--|
| | Basic Model | Frame Color | Poly Seat/Back Color | Base | Fire Code | Upholstery Color | | | | | | | | | | | | |
|  <p>Armless Chair with Poly Seat • Flex back • Nests</p> | SNNAP | <input type="checkbox"/> | <input type="checkbox"/> | <input type="checkbox"/> | <input type="checkbox"/> | <input type="checkbox"/> | 23.0# | \$ 500 | | | | | | | | | | |
| SNP | | | | | | | | | | | | | | | | | | |
|  <p>Armless Chair with Upholstered Seat • Flex back • Nests</p> | SNNAU | <input type="checkbox"/> | <input type="checkbox"/> | <input type="checkbox"/> | <input type="checkbox"/> | <input type="checkbox"/> | 23.0# | N/A | \$ 572 | \$ 604 | \$ 620 | \$ 572 | \$ 620 | \$ 618 | \$ 663 | \$ 686 | \$ 712 | \$ 732 |
| SNU | | | | | | | | | | | | | | | | | | |
|  <p>Arm Chair with Poly Seat • Flex back • Nests</p> | SNCAP | <input type="checkbox"/> | <input type="checkbox"/> | <input type="checkbox"/> | <input type="checkbox"/> | <input type="checkbox"/> | 25.0# | \$ 568 | | | | | | | | | | |
| SNP | | | | | | | | | | | | | | | | | | |
|  <p>Arm Chair with Upholstered Seat • Flex back • Nests</p> | SNCAU | <input type="checkbox"/> | <input type="checkbox"/> | <input type="checkbox"/> | <input type="checkbox"/> | <input type="checkbox"/> | 25.0# | N/A | \$ 642 | \$ 673 | \$ 689 | \$ 642 | \$ 689 | \$ 685 | \$ 731 | \$ 753 | \$ 779 | \$ 801 |
| SNU | | | | | | | | | | | | | | | | | | |
| | A | B | C | D | E | F | | | | | | | | | | | | |

HOW TO ORDER

Indicate the following information on order form:
 1. Quantity of each item.
 2. Model number, including options. See "How To Build a Model Number".
 3. Any special service required.

Note: • The indicates that a choice is required.
 • The absence of the indicates that no choice is required.
 • Alpha-numeric characters in place of indicate that no other alternatives are available.

HOW TO BUILD A MODEL NUMBER

- A** Select basic model.
- B** Select frame color.
Refer to the **Product Color Options** page in this price list.
- C** Select poly seat and back color
Refer to the **Product Color Options** page in this price list.
- D** Select base option.

| | |
|----------|-----------------------------------|
| G | - Bell glides (black only) |
| C | - Carpet casters (black only) |
| S | - Hard floor casters (black only) |
- E** Select fire code.

| | |
|------------|-----------------------------|
| NFR | - Compliance to TB 117-2013 |
| FR | - Compliance to TB 133 |
- F** Select upholstery grade/color.
Refer to ki.com/fabrics

UPHOLSTERY INFORMATION

C.O.M. Upholstery
 C.O.M. requirement for 10 chairs or less with upholstered seat or upholstered seat and back is 3/4 yard per chair of 54" wide nondirectional fabric. For orders of 11 or more with upholstered seat and back and for complete information on ordering C.O.M. see "Ordering C.O.M., C.O.V. and C.O.L." section.

OPTIONS

California TB133 Fire Safety Code
 For California Technical Bulletin 133 compliant models, add the following upcharge:

 Model=Polypropylene
 Added list price=\$12

 Model=Upholstered Seat
 Added list price=\$84





SPECIAL SERVICES

Special Carton Marking
 With specially marked information N/C

Shipping
 Ships **assembled, FOB Green Bay, WI 54302, freight prepaid.** Freight class 125.

Specifications and prices are subject to change without prior notice.



| MODEL | MODEL NUMBER | | | | | | | Approx. Packaged Weight | Delivered Pricing | Delivered Pricing Fabric Grade 1 & C.O.M. | Delivered Pricing Fabric Grade 2 | Delivered Pricing Fabric Grade 3 | Delivered Pricing C.O.V. | Delivered Pricing Vinyl Group 2V | Delivered Pricing Pallas Fabric Group P0 | Delivered Pricing Pallas Fabric Group P1 | Delivered Pricing Pallas Fabric Group P2 | Delivered Pricing Pallas Fabric Group P3 | Delivered Pricing Pallas Fabric Group P4 |
|--|--------------|--------------------------|--------------------------|--------------------------|--------------------------|--------------------------|--------------------------|-------------------------|-------------------|---|----------------------------------|----------------------------------|--------------------------|----------------------------------|--|--|--|--|--|
| | Basic Model | Frame Color | Poly Seat/Back Color | Base | Tablet Arm Color | Fire Code | Upholstery Color | | | | | | | | | | | | |
|  Tablet Arm Chair with Poly Seat • Flex back • Nests SNP | SNTAPRH | <input type="checkbox"/> | <input type="checkbox"/> | <input type="checkbox"/> | <input type="checkbox"/> | <input type="checkbox"/> | <input type="checkbox"/> | 28.0# | \$ 712 | | | | | | | | | | |
| | SNTAPLH | <input type="checkbox"/> | <input type="checkbox"/> | <input type="checkbox"/> | <input type="checkbox"/> | <input type="checkbox"/> | <input type="checkbox"/> | 28.0# | 712 | | | | | | | | | | |
|  Tablet Arm Chair with Upholstered Seat • Flex back • Nests SNU | SNTAURH | <input type="checkbox"/> | <input type="checkbox"/> | <input type="checkbox"/> | <input type="checkbox"/> | <input type="checkbox"/> | <input type="checkbox"/> | 28.0# | N/A | \$ 784 | \$ 816 | \$ 831 | \$ 784 | \$ 831 | \$ 829 | \$ 874 | \$ 896 | \$ 923 | \$ 944 |
| | SNTAULH | <input type="checkbox"/> | <input type="checkbox"/> | <input type="checkbox"/> | <input type="checkbox"/> | <input type="checkbox"/> | <input type="checkbox"/> | 28.0# | N/A | 784 | 816 | 831 | 784 | 831 | 829 | 874 | 896 | 923 | 944 |
|  Oversize Tablet Arm Chair with Poly Seat • Flex back • Nests SNP | SNOVTAPRH | <input type="checkbox"/> | <input type="checkbox"/> | <input type="checkbox"/> | <input type="checkbox"/> | <input type="checkbox"/> | <input type="checkbox"/> | 28.0# | \$ 784 | | | | | | | | | | |
| | SNOVTAPLH | <input type="checkbox"/> | <input type="checkbox"/> | <input type="checkbox"/> | <input type="checkbox"/> | <input type="checkbox"/> | <input type="checkbox"/> | 28.0# | 784 | | | | | | | | | | |
|  Oversize Tablet Arm Chair with Upholstered Seat • Flex back • Nests SNU | SNOVTAURH | <input type="checkbox"/> | <input type="checkbox"/> | <input type="checkbox"/> | <input type="checkbox"/> | <input type="checkbox"/> | <input type="checkbox"/> | 28.0# | N/A | \$ 857 | \$ 888 | \$ 905 | \$ 857 | \$ 905 | \$ 900 | \$ 946 | \$ 971 | \$ 996 | \$ 1016 |
| | SNOVTAULH | <input type="checkbox"/> | <input type="checkbox"/> | <input type="checkbox"/> | <input type="checkbox"/> | <input type="checkbox"/> | <input type="checkbox"/> | 28.0# | N/A | 857 | 888 | 905 | 857 | 905 | 900 | 946 | 971 | 996 | 1016 |

A **B** **C** **D** **E** **F** **G**

HOW TO ORDER

- Indicate the following information on order form:
- Quantity of each item.
 - Model number, including options. See "How To Build a Model Number".
 - Any special service required.

Note: • The indicates that a choice is required.
 • The absence of the indicates that no choice is required.
 • Alpha-numeric characters in place of indicate that no other alternatives are available.

HOW TO BUILD A MODEL NUMBER

- A** Select basic model.
- B** Select frame color. Refer to the **Product Color Options** page in this price list.
- C** Select poly seat and back color. Refer to the **Product Color Options** page in this price list.
- D** Select base option.
 - G** - Bell glides (black only)
 - C** - Carpet casters (black only)
 - S** - Hard floor casters (black only)
- E** Select tablet arm color. Refer to the **Product Color Options** page in this price list.
- F** Select fire code.
 - NFR** - Compliance to TB 117-2013
 - FR** - Compliance to TB 133

G Select upholstery grade/color. Refer to ki.com/fabrics

UPHOLSTERY INFORMATION

C.O.M. Upholstery
 C.O.M. requirement for 10 chairs or less with upholstered seat or upholstered seat and back is 3/4 yard per chair of 54" wide nondirectional fabric. For orders of 11 or more with upholstered seat and back and for complete information on ordering C.O.M. see "Ordering C.O.M., C.O.V. and C.O.L." section.

OPTIONS

California TB133 Fire Safety Code
 For California Technical Bulletin 133 compliant models, add the following upcharge:
 Model=Polypropylene
 Added list price=\$12
 Model=Upholstered Seat
 Added list price=\$84

SPECIAL SERVICES

Special Carton Marking
 With specially marked information N/C
Shipping
 Ships **assembled, FOB Green Bay, WI 54302, freight prepaid.** Freight class 125.
 Specifications and prices are subject to change without prior notice.



1-Place Unit
(1 Seat, 0 In-Line Table)

2-Place Unit
(1 Seat, 1 In-Line Table;
2 Seat, 0 In-Line Table)

3-Place Unit
(2 Seats, 1 In-Line Table;
3 Seats, 0 In-Line Table)

4-Place Unit
(3 Seats, 1 In-Line Table;
4 Seats, 0 In-Line Table)

| Features | | | | |
|--|-----------|-----------|-----------|-----------|
| Arm | • | • | • | • |
| Corner tables | • | • | • | • |
| In-line tables | • | • | • | • |
| Poly, upholstered seat, or upholstered seat/back | • | • | • | • |
| General Dimensions | | | | |
| Seat width | 18" | 18" | 18" | 18" |
| Seat depth | 18" | 18" | 18" | 18" |
| Seat height | 17" | 17" | 17" | 17" |
| Unit width (with arms) | 28" | 50" | 72" | 94" |
| Unit width (no arms) | 28" | 50" | 72" | 88" |
| Unit height | 33" | 33" | 33" | 33" |
| Corner table top | 30" x 30" | 30" x 30" | 30" x 30" | 30" x 30" |
| In-line table | 20" x 20" | 20" x 20" | 20" x 20" | 20" x 20" |
| | | | | |
| Table height (all table models) | 17" | 17" | 17" | 17" |
| Width between arms (inside arm) | 18" | 18" | 18" | 18" |
| Arm height from floor | 25-3/4" | 25-3/4" | 25-3/4" | 25-3/4" |

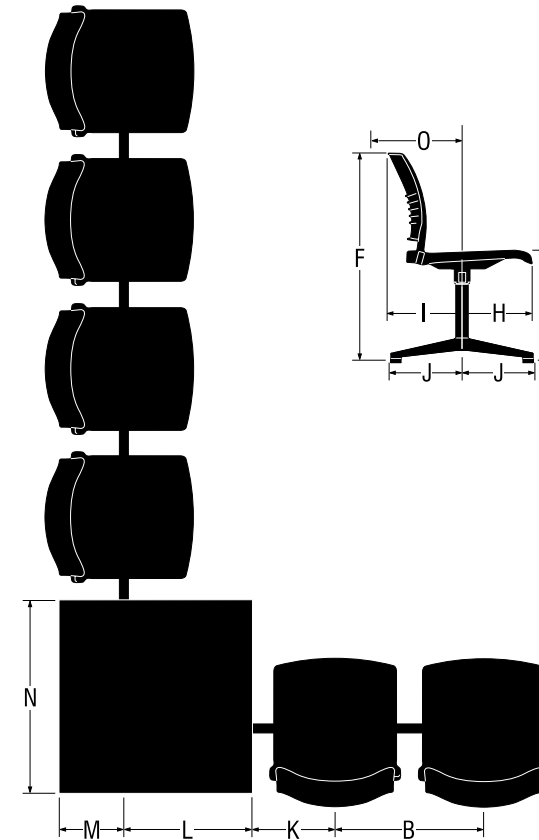
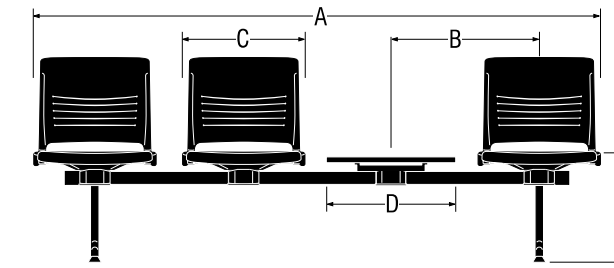

DIMENSIONS

| | | No Arms | With Arms |
|----|------------------------------------|---------|-----------|
| A1 | 2-Place Unit | 44 1/2" | 44 1/2" |
| A2 | 3-Place Unit | 66 1/2" | 66 1/2" |
| A3 | 4-Place Unit | 85 1/2" | 92 1/2" |
| B | Additional Places | 22" | 22" |
| C | Seat Width | 18" | |
| D | Table Width | 20" | |
| E | Table Height | 17" | |
| F | Unit Height | 33" | |
| G | Seat Height | 17" | |
| H | Beam Center to Front of Seat | 10 1/4" | |
| I | Beam Center to Back of Back | 11" | |
| J | Beam Center to Foot End | 11 1/2" | |
| K | Seat Center to Corner Table | | |
| | Mounting Side | 13 1/2" | |
| L | Beam Center to Corner Table | | |
| | Mounting Side | 20" | |
| M | Beam Center to Corner Table Back | 10" | |
| N | Corner Table Width | 30" | |
| O | Beam Center to Back of Flexed Back | 14 1/4" | |

SPECIFICATIONS

Tandem Base

Cast aluminum alloy leg section. 14-gauge 1x2" seamless steel column. Upright and base are painted monochromatic with beam and yoke. Columns are welded to a plate which clamps onto beam.

Frame Finish

Baked-on, electrostatically-applied 45 gloss epoxy powder coating.

Seat

Injection-molded polypropylene seat attached directly to the structure.

Underseat Structure

Support structure is die-formed 13-gauge steel welded to a 1" OD x 14-gauge tubular steel cross member.

Backrest

Injection molded polypropylene with integral steel cantilever springs. The combination of

the slotted polypropylene back and the spring steel provides a supportive flexing back. Springs are nominal 4.5mm diameter chrome silicon valve spring wire.

Tandem Arm

Oval tubular steel arm support with self-skinning urethane armrests measuring 10 1/4" long x 4" wide. The tubular arm support is welded to a yoke and then fastened to the beam via a coverplate.

Optional Upholstered Seat or Seat & Back

Molded urethane foam is attached to an injection molded polypropylene seat board, then upholstered using a draw-string process. The assembled seat pad is attached to the seat by means of hidden fasteners.

In-Line Table

Solid core top is 20" x 20" x 7/8" with a vinyl bullnose edge.

Corner Table

Solid core top is 30" x 30" x 7/8" with a vinyl

bullnose edge.

KI Color Match Program

KI offers the additional option of color matching paint, polypropylene, or wood stain through Product Modification Requests. Contact Customer Service for details.

Whatever you imagine, whatever you require, KI's Color Match program lets you pick your color!

[Color Match Process - Poly Seating Information can be found here.](#)

INFORMATION

Warranty

Refer to KI Terms & Conditions document or visit ki.com

**Frame Color**

Black
Blue Grey
Cool Grey
Earthen Clay
Everglade Shade
Flannel
Hazy Jade
Light Tone
Mardi Gras
Misty Brown
Nemo
Poppy Red
Purple Haze
Rubber Ducky
Sand
Sky Blue
Surf's Up
Twilight Shadow
Ultra Blue
Warm Grey
Zesty Lime

Edge Color

Black
Blue Grey
Cool Grey
Earthen Clay
Everglade Shade
Flannel
Frosty White
Hazy Jade
Light Tone
Mardi Gras
Misty Brown
Nemo
Purple Haze
Rubber Ducky
Sand
Surf's Up
Twilight Shadow
Ultra Blue
Warm Grey
Zesty Lime

Seat and Back Color - Polypropylene**Non Flame-Retardant**

BL Black
GR Blue Grey
CG Cool Grey
EY Earthen Clay
EV Everglade Shade
FN Flannel
HJ Hazy Jade
LG Light Tone
MG Mardi Gras
MY Misty Brown
NE Nemo
PR Poppy Red
PH Purple Haze
RK Rubber Ducky
SA Sand
SK Sky Blue
SP Surf's Up
ZL Zesty Lime
EBL Black
EGR Blue Grey
ECG Cool Grey
EEY Earthen Clay
EEV Everglade Shade
EFN Flannel
EFW Frosty White
EHJ Hazy Jade
ELG Light Tone
EMG Mardi Gras
EMY Misty Brown
ENE Nemo
EPH Purple Haze
ERK Rubber Ducky
ESA Sand
ESP Surf's Up
ETI Twilight Shadow
EUB Ultra Blue
EWG Warm Grey
EZL Zesty Lime

Arm pad matches seat and back color for black, blue grey, sand and warm grey. Otherwise it is always black.

TRANSLUCENT colors are available on the upholstered seat models only.

**Seat and Back Color - Polypropylene
Flame-Retardant**

Black
PBL Black
PGR Blue Grey
PCY Cayenne
PCG Cool Grey
PEY Earthen Clay
PEV Everglade Shade
PFN Flannel
PHJ Hazy Jade
PHY Honey Bee
PLG Light Tone
PMG Mardi Gras
PMY Misty Brown
PNE Nemo
PND Nordic
PPR Poppy Red
PPH Purple Haze
PRK Rubber Ducky
PSA Sand
PSK Sky Blue
PSP Surf's Up
PTI Twilight Shadow
PUB Ultra Blue
PWG Warm Grey
PZL Zesty Lime

Arm pad matches seat and back color for black, blue grey, sand and warm grey. Otherwise it is always black.

The above seating product can be manufactured using the appropriate flame-retardant materials for compliance to California Technical Bulletin 133.

*NOTE: When FR upholstery is selected, FR poly (black only) must be selected. NFR poly is not available with FR upholstery.

Surface Finish - Laminate

PBL Belair
PGR Biltmore Cherry
PCY Black
PCG Brighton Walnut
PEY Canyon Zephyr
PEV Castle Oak
PFN Casual Linen
PHJ Cherry Storm
PHY Classic Linen
PLG Cloud Zephyr
PMG Cocobala
PMY Crisp Linen
PNE Desert Zephyr
PND Dove Grey
PPR Fired Steel
PPH Flax Linen
PRK Florence Walnut
PSA Forged Steel
PSK Friston Ash
PSP Frosty White
PTI Graphite Nebula
PUB Grey
PWG High Rise
PZL Hollyberry
Irish Linen
Island
Italian Silver Ash
Kensington Maple
Lapin Blue
Markerboard White
Misted Zephyr
Monticello Maple
Nickel Evolv
North Sea
Ocean
Pearl Bisque
Pearl Silver
Pressed Linen
River Cherry
Rugged Linen
Satin Stainless
Shadow Zephyr
Silicon evolv
Sterling Ash
Tailored Linen
Titanium evolv
White Nebula
White Sand
Windsor Mahogany

LBQ
LBT
LBK
LBW
LCA
LCO
LCU
LCX
LCI
LCL
LCC
LRI
LDZ
LDG
LIL
LXF
LFC
LOL
LFH
LFW
LGN
LGE
LHE
LHY
LIH
LID
LIT
LKM
LLB
LMK
LMR
LMT
LNV
LNA
LON
LPB
LPS
LPR
LRY
LRG
LSS
LSR
LSV
LAZ
LTL
LTV
LWL
LWN
LWY



Finish Cards

View color swatches for items listed within this document.

Paints**Plastics/Poly****Wood/Veneer****Laminates****Molded Edges****Edge Styles****Hard Plastics****Glass**

Certain options referenced may not be available on GSA Schedule.



| MODEL | Features | MODEL NUMBER | | | | | | Approx. Packaged Weight | Delivered Pricing | TB133 add to list price | |
|---|--|---------------------------|---------------|--------------------------|--------------------------|--------------------------|--------------------------|--------------------------|-------------------|-------------------------|-------|
| | | Basic Model | Frame Color | Fire Code | Seat & Back Color | Surface Finish | Edge Color | | | | |
|  <p>ST1P ST2P ST3P ST4P ST5P</p> | Polypropylene - No Arms • Optional in-line tables • 1 seat, 0 in-line table models must connect to a corner table • Corner table is ordered separately | 1 Seat, 0 In-Line Table | ST1NAP/S1/IT0 | <input type="checkbox"/> | <input type="checkbox"/> | <input type="checkbox"/> | | | 25.0# | \$ 467 | \$ 12 |
| | | 1 Seat, 1 In-Line Table | ST2NAP/S1/IT1 | <input type="checkbox"/> | <input type="checkbox"/> | <input type="checkbox"/> | <input type="checkbox"/> | <input type="checkbox"/> | 39.0# | 989 | 12 |
| | | 2 Seats, 0 In-Line Table | ST2NAP/S2/IT0 | <input type="checkbox"/> | <input type="checkbox"/> | <input type="checkbox"/> | | | 45.0# | 932 | 27 |
| | | 2 Seats, 1 In-Line Table | ST3NAP/S2/IT1 | <input type="checkbox"/> | <input type="checkbox"/> | <input type="checkbox"/> | <input type="checkbox"/> | <input type="checkbox"/> | 59.0# | 1455 | 27 |
| | | 3 Seats, 0 In-Line Table | ST3NAP/S3/IT0 | <input type="checkbox"/> | <input type="checkbox"/> | <input type="checkbox"/> | | | 65.0# | 1400 | 39 |
| | | 3 Seats, 1 In-line Table | ST4NAP/S3/IT1 | <input type="checkbox"/> | <input type="checkbox"/> | <input type="checkbox"/> | <input type="checkbox"/> | <input type="checkbox"/> | 79.0# | 1923 | 39 |
| | | 4 Seats, 0 In-line Table | ST4NAP/S4/IT0 | <input type="checkbox"/> | <input type="checkbox"/> | <input type="checkbox"/> | | | 89.0# | 1868 | 51 |
| | | 3 Seats, 2 In-Line Tables | ST5NAP/S3/IT2 | <input type="checkbox"/> | <input type="checkbox"/> | <input type="checkbox"/> | <input type="checkbox"/> | <input type="checkbox"/> | 98.0# | 2445 | 39 |
| | | 4 Seats, 1 In-line Table | ST5NAP/S4/IT1 | <input type="checkbox"/> | <input type="checkbox"/> | <input type="checkbox"/> | <input type="checkbox"/> | <input type="checkbox"/> | 104.0# | 2388 | 51 |
| | | 5 Seats, 0 In-line Table | ST5NAP/S5/IT0 | <input type="checkbox"/> | <input type="checkbox"/> | <input type="checkbox"/> | | | 110.0# | 2334 | 66 |
|  <p>ST1P ST2P ST3P ST4P ST5P</p> | Polypropylene - End Arms Only • Optional in-line tables • 1 seat, 0 in-line table models must connect to a corner table • Corner table is ordered separately | 1 Seat, 0 In-Line Table | ST1EAP/S1/IT0 | <input type="checkbox"/> | <input type="checkbox"/> | <input type="checkbox"/> | | | 30.0# | \$ 642 | \$ 12 |
| | | 1 Seat, 1 In-Line Table | ST2EAP/S1/IT1 | <input type="checkbox"/> | <input type="checkbox"/> | <input type="checkbox"/> | <input type="checkbox"/> | <input type="checkbox"/> | 44.0# | 1076 | 12 |
| | | 2 Seats, 0 In-Line Table | ST2EAP/S2/IT0 | <input type="checkbox"/> | <input type="checkbox"/> | <input type="checkbox"/> | | | 47.0# | 1105 | 27 |
| | | 2 Seats, 1 In-Line Table | ST3EAP/S2/IT1 | <input type="checkbox"/> | <input type="checkbox"/> | <input type="checkbox"/> | <input type="checkbox"/> | <input type="checkbox"/> | 55.0# | 1627 | 27 |
| | | 3 Seats, 0 In-Line Table | ST3EAP/S3/IT0 | <input type="checkbox"/> | <input type="checkbox"/> | <input type="checkbox"/> | | | 64.0# | 1575 | 39 |
| | | 3 Seats, 1 In-line Table | ST4EAP/S3/IT1 | <input type="checkbox"/> | <input type="checkbox"/> | <input type="checkbox"/> | <input type="checkbox"/> | <input type="checkbox"/> | 70.0# | 2096 | 39 |
| | | 4 Seats, 0 In-line Table | ST4EAP/S4/IT0 | <input type="checkbox"/> | <input type="checkbox"/> | <input type="checkbox"/> | | | 81.0# | 2040 | 51 |
| | | 3 Seats, 2 In-Line Tables | ST5EAP/S3/IT2 | <input type="checkbox"/> | <input type="checkbox"/> | <input type="checkbox"/> | <input type="checkbox"/> | <input type="checkbox"/> | 89.0# | 2617 | 39 |
| | | 4 Seats, 1 In-line Table | ST5EAP/S4/IT1 | <input type="checkbox"/> | <input type="checkbox"/> | <input type="checkbox"/> | <input type="checkbox"/> | <input type="checkbox"/> | 100.0# | 2563 | 51 |
| | | 5 Seats, 0 In-line Table | ST5EAP/S5/IT0 | <input type="checkbox"/> | <input type="checkbox"/> | <input type="checkbox"/> | | | 105.0# | 2509 | 66 |
|  <p>ST1P ST2P ST3P ST4P ST5P</p> | Polypropylene - Arms • Optional in-line tables • 1 seat, 0 in-line table models must connect to a corner table • Corner table is ordered separately | 1 Seat, 0 In-Line Table | ST1AAP/S1/IT0 | <input type="checkbox"/> | <input type="checkbox"/> | <input type="checkbox"/> | | | 30.0# | \$ 642 | \$ 12 |
| | | 1 Seat, 1 In-Line Table | ST2AAP/S1/IT1 | <input type="checkbox"/> | <input type="checkbox"/> | <input type="checkbox"/> | <input type="checkbox"/> | <input type="checkbox"/> | 44.0# | 1162 | 12 |
| | | 2 Seats, 0 In-Line Table | ST2AAP/S2/IT0 | <input type="checkbox"/> | <input type="checkbox"/> | <input type="checkbox"/> | | | 55.0# | 1194 | 27 |
| | | 2 Seats, 1 In-Line Table | ST3AAP/S2/IT1 | <input type="checkbox"/> | <input type="checkbox"/> | <input type="checkbox"/> | <input type="checkbox"/> | <input type="checkbox"/> | 69.0# | 1804 | 27 |
| | | 3 Seats, 0 In-Line Table | ST3AAP/S3/IT0 | <input type="checkbox"/> | <input type="checkbox"/> | <input type="checkbox"/> | | | 80.0# | 1747 | 39 |
| | | 3 Seats, 1 In-line Table | ST4AAP/S3/IT1 | <input type="checkbox"/> | <input type="checkbox"/> | <input type="checkbox"/> | <input type="checkbox"/> | <input type="checkbox"/> | 94.0# | 2357 | 39 |
| | | 4 Seats, 0 In-line Table | ST4AAP/S4/IT0 | <input type="checkbox"/> | <input type="checkbox"/> | <input type="checkbox"/> | | | 105.0# | 2302 | 51 |
| | | 3 Seats, 2 In-Line Tables | ST5AAP/S3/IT2 | <input type="checkbox"/> | <input type="checkbox"/> | <input type="checkbox"/> | <input type="checkbox"/> | <input type="checkbox"/> | 113.0# | 2965 | 39 |
| | | 4 Seats, 1 In-line Table | ST5AAP/S4/IT1 | <input type="checkbox"/> | <input type="checkbox"/> | <input type="checkbox"/> | <input type="checkbox"/> | <input type="checkbox"/> | 124.0# | 2911 | 51 |
| | | 5 Seats, 0 In-line Table | ST5AAP/S5/IT0 | <input type="checkbox"/> | <input type="checkbox"/> | <input type="checkbox"/> | | | 135.0# | 2856 | 66 |

A **B** **C** **D** **E** **F**

HOW TO ORDER

- Indicate the following information on order form:
- Quantity of each item.
 - Model number, including options. See "How To Build a Model Number".
 - Any special service required.

Note: • The indicates that a choice is required.
 • The absence of the indicates that no choice is required.
 • Alpha-numeric characters in place of indicate that no other alternatives are available.

HOW TO BUILD A MODEL NUMBER

- A** Select basic model.
- B** Select frame color. Refer to the **Product Color Options** page in this price list.
- C** Select fire code.
 FR - Compliance to TB 133
 NFR - No Fire Retardant
 See pricing column for TB133 upcharge.
- D** Select seat/back color. Refer to the **Product Color Options** page in this price list.
- E** Select surface finish for table. Refer to the **Product Color Options** page in this price list. Surface finish offerings are based on edge style selections.
- F** Select table edge color. Refer to the **Product Color Options** page in this price list. Edge color offerings are based on edge style selections.

OPTIONS

California TB133 Fire Safety Code
 For California Technical Bulletin 133 compliant models, a Product Modification Request is required. Contact Customer Service for details.

SPECIAL SERVICES



Special Carton Marking

With specially marked information N/C

Shipping
 Ships **knocked down, FOB Green Bay, WI 54302, freight prepaid.** Freight class 70.

Specifications and prices are subject to change without prior notice.



| MODEL | Features | MODEL NUMBER | | | | | | | Approx. Packaged Weight | Delivered Pricing Fabric Grade 1 & C.O.M. | Delivered Pricing Fabric Grade 2 | Delivered Pricing Fabric Grade 3 | Delivered Pricing C.O.V. | Delivered Pricing Vinyl Group 2V | Delivered Pricing Pallas Fabric Group P0 | Delivered Pricing Pallas Fabric Group P1 | Delivered Pricing Pallas Fabric Group P2 | Delivered Pricing Pallas Fabric Group P3 | Delivered Pricing Pallas Fabric Group P4 | TB133 add to list price |
|--|---------------------------|---------------|--------------------------|--------------------------|--------------------------|--------------------------|--------------------------|--------------------------|-------------------------|---|----------------------------------|----------------------------------|--------------------------|----------------------------------|--|--|--|--|--|-------------------------|
| | | Basic Model | Frame Color | Seat & Back Color | Surface Finish | Edge Color | Fire Code | Upholstery Color | | | | | | | | | | | | |
|  <p>Upholstered Seat - No Arms</p> <ul style="list-style-type: none"> Optional in-line tables 1 seat, 0 in-line table models must connect to a corner table Corner table is ordered separately | 1 Seat, 0 In-Line Table | ST1NAU/S1/IT0 | <input type="checkbox"/> | <input type="checkbox"/> | | | <input type="checkbox"/> | <input type="checkbox"/> | 30.0# | \$ 538 | \$ 572 | \$ 590 | \$ 538 | \$ 590 | \$ 585 | \$ 630 | \$ 654 | \$ 678 | \$ 702 | \$ 84 |
| | 1 Seat, 1 In-Line Table | ST2NAU/S1/IT1 | <input type="checkbox"/> | <input type="checkbox"/> | <input type="checkbox"/> | <input type="checkbox"/> | <input type="checkbox"/> | <input type="checkbox"/> | 41.0# | 1061 | 1094 | 1076 | 1061 | 1076 | 1070 | 1117 | 1141 | 1167 | 1187 | 84 |
| | 2 Seats, 0 In-Line Table | ST2NAU/S2/IT0 | <input type="checkbox"/> | <input type="checkbox"/> | | | <input type="checkbox"/> | <input type="checkbox"/> | 50.0# | 1079 | 1145 | 1173 | 1079 | 1173 | 1166 | 1258 | 1308 | 1357 | 1397 | 168 |
| | 2 Seats, 1 In-Line Table | ST3NAU/S2/IT1 | <input type="checkbox"/> | <input type="checkbox"/> | <input type="checkbox"/> | <input type="checkbox"/> | <input type="checkbox"/> | <input type="checkbox"/> | 64.0# | 1745 | 1812 | 1841 | 1745 | 1841 | 1833 | 1926 | 1974 | 2022 | 2063 | 168 |
| | 3 Seats, 0 In-Line Table | ST3NAU/S3/IT0 | <input type="checkbox"/> | <input type="checkbox"/> | | | <input type="checkbox"/> | <input type="checkbox"/> | 70.0# | 1618 | 1718 | 1760 | 1618 | 1760 | 1749 | 1887 | 1961 | 2035 | 2096 | 251 |
| | 3 Seats, 1 In-Line Table | ST4NAU/S3/IT1 | <input type="checkbox"/> | <input type="checkbox"/> | <input type="checkbox"/> | <input type="checkbox"/> | <input type="checkbox"/> | <input type="checkbox"/> | 84.0# | 2141 | 2240 | 2284 | 2141 | 2284 | 2272 | 2408 | 2482 | 2557 | 2617 | 251 |
| | 4 Seats, 0 In-Line Table | ST4NAU/S4/IT0 | <input type="checkbox"/> | <input type="checkbox"/> | | | <input type="checkbox"/> | <input type="checkbox"/> | 94.0# | 2156 | 2290 | 2349 | 2156 | 2349 | 2334 | 2519 | 2615 | 2713 | 2795 | 334 |
| | 3 Seats, 2 In-Line Tables | ST5NAU/S3/IT2 | <input type="checkbox"/> | <input type="checkbox"/> | <input type="checkbox"/> | <input type="checkbox"/> | <input type="checkbox"/> | <input type="checkbox"/> | 103.0# | 2662 | 2761 | 2805 | 2662 | 2805 | 2793 | 2929 | 3004 | 3077 | 3137 | 251 |
| | 4 Seats, 1 In-Line Table | ST5NAU/S4/IT1 | <input type="checkbox"/> | <input type="checkbox"/> | <input type="checkbox"/> | <input type="checkbox"/> | <input type="checkbox"/> | <input type="checkbox"/> | 109.0# | 2677 | 2811 | 2873 | 2677 | 2873 | 2858 | 3040 | 3135 | 3236 | 3316 | 334 |
| | 5 Seats, 0 In-Line Table | ST5NAU/S5/IT0 | <input type="checkbox"/> | <input type="checkbox"/> | | | <input type="checkbox"/> | <input type="checkbox"/> | 115.0# | 2697 | 2863 | 2935 | 2697 | 2935 | 2917 | 3145 | 3269 | 3391 | 3492 | 417 |
| ST1U | | | | | | | | | | | | | | | | | | | | |
| ST2U | | | | | | | | | | | | | | | | | | | | |
| ST3U | | | | | | | | | | | | | | | | | | | | |
| ST4U | | | | | | | | | | | | | | | | | | | | |
| ST5U | | | | | | | | | | | | | | | | | | | | |
|  <p>Upholstered Seat - End Arms Only</p> <ul style="list-style-type: none"> Optional in-line tables 1 seat, 0 in-line table models must connect to a corner table Corner table is ordered separately | 1 Seat, 0 In-Line Table | ST1EAU/S1/IT0 | <input type="checkbox"/> | <input type="checkbox"/> | | | <input type="checkbox"/> | <input type="checkbox"/> | 35.0# | \$ 713 | \$ 747 | \$ 761 | \$ 713 | \$ 761 | \$ 758 | \$ 803 | \$ 826 | \$ 853 | \$ 873 | \$ 84 |
| | 1 Seat, 1 In-Line Table | ST2EAU/S1/IT1 | <input type="checkbox"/> | <input type="checkbox"/> | <input type="checkbox"/> | <input type="checkbox"/> | <input type="checkbox"/> | <input type="checkbox"/> | 49.0# | 1148 | 1183 | 1196 | 1148 | 1196 | 1192 | 1238 | 1262 | 1287 | 1308 | 84 |
| | 2 Seats, 0 In-Line Table | ST2EAU/S2/IT0 | <input type="checkbox"/> | <input type="checkbox"/> | | | <input type="checkbox"/> | <input type="checkbox"/> | 52.0# | 1254 | 1318 | 1348 | 1254 | 1348 | 1341 | 1432 | 1481 | 1529 | 1573 | 168 |
| | 2 Seats, 1 In-Line Table | ST3EAU/S2/IT1 | <input type="checkbox"/> | <input type="checkbox"/> | <input type="checkbox"/> | <input type="checkbox"/> | <input type="checkbox"/> | <input type="checkbox"/> | 60.0# | 1775 | 1841 | 1870 | 1775 | 1870 | 1863 | 1954 | 2003 | 2054 | 2091 | 168 |
| | 3 Seats, 0 In-Line Table | ST3EAU/S3/IT0 | <input type="checkbox"/> | <input type="checkbox"/> | | | <input type="checkbox"/> | <input type="checkbox"/> | 69.0# | 1791 | 1892 | 1935 | 1791 | 1935 | 1924 | 2061 | 2134 | 2207 | 2270 | 251 |
| | 3 Seats, 1 In-Line Table | ST4EAU/S3/IT1 | <input type="checkbox"/> | <input type="checkbox"/> | <input type="checkbox"/> | <input type="checkbox"/> | <input type="checkbox"/> | <input type="checkbox"/> | 75.0# | 2314 | 2412 | 2457 | 2314 | 2457 | 2447 | 2583 | 2659 | 2733 | 2793 | 251 |
| | 4 Seats, 0 In-Line Table | ST4EAU/S4/IT0 | <input type="checkbox"/> | <input type="checkbox"/> | | | <input type="checkbox"/> | <input type="checkbox"/> | 86.0# | 2332 | 2464 | 2524 | 2332 | 2524 | 2507 | 2690 | 2788 | 2886 | 2969 | 334 |
| | 3 Seats, 2 In-Line Tables | ST5EAU/S3/IT2 | <input type="checkbox"/> | <input type="checkbox"/> | <input type="checkbox"/> | <input type="checkbox"/> | <input type="checkbox"/> | <input type="checkbox"/> | 94.0# | 2836 | 2935 | 2979 | 2836 | 2979 | 2968 | 3104 | 3178 | 3254 | 3314 | 251 |
| | 4 Seats, 1 In-Line Table | ST5EAU/S4/IT1 | <input type="checkbox"/> | <input type="checkbox"/> | <input type="checkbox"/> | <input type="checkbox"/> | <input type="checkbox"/> | <input type="checkbox"/> | 105.0# | 2851 | 2988 | 3045 | 2851 | 3045 | 3029 | 3211 | 3311 | 3410 | 3489 | 334 |
| | 5 Seats, 0 In-Line Table | ST5EAU/S5/IT0 | <input type="checkbox"/> | <input type="checkbox"/> | | | <input type="checkbox"/> | <input type="checkbox"/> | 110.0# | 2873 | 3038 | 3111 | 2873 | 3111 | 3091 | 3319 | 3443 | 3564 | 3667 | 417 |

A **B** **C** **D** **E** **F** **G**

HOW TO ORDER

- Indicate the following information on order form:
- Quantity of each item.
 - Model number, including options. See "How To Build a Model Number".
 - Any special service required.

Note:

- The indicates that a choice is required.
- The absence of the indicates that no choice is required.
- Alpha-numeric characters in place of indicate that no other alternatives are available.

HOW TO BUILD A MODEL NUMBER

- A** Select basic model.
- B** Select frame color. Refer to the **Product Color Options** page in this price list.
- C** Select seat/back color. Refer to the **Product Color Options** page in this price list.
- D** Select surface finish for table. Refer to the **Product Color Options** page in this price list. Surface finish offerings are based on edge style selections.
- E** Select table edge color. Refer to the **Product Color Options** page in this price list. Edge color offerings are based on edge style selections.

- F** Select fire code.
 - NFR** - Compliance to TB 117-2013
 - FR** - Compliance to TB 133
 See pricing column for TB133 upcharge.
- G** Select upholstery grade/color. Refer to ki.com/fabrics

UPHOLSTERY INFORMATION

C.O.M. Upholstery
 C.O.M. requirement for 10 chairs or less with upholstered seat or upholstered seat and back is 3/4 yard per chair of 54" wide nondirectional fabric. For orders of 11 or more with upholstered seat and back and for complete information on ordering C.O.M. see "Ordering C.O.M., C.O.V. and C.O.L." section.

OPTIONS

California TB133 Fire Safety Code
 The above seating products can be manufactured using the appropriate flame-retardant materials for compliance to California Technical Bulletin 133. See pricing column for upcharge. Please contact KI customer service for fabric compliance. No additional lead time.

SPECIAL SERVICES

Special Carton Marking
 With specially marked information N/C

Shipping
 Ships **knocked down, FOB Green Bay, WI 54302, freight prepaid.** Freight class 70.

Specifications and prices are subject to change without prior notice.



| MODEL | Features | MODEL NUMBER | | | | | | | Approx. Packaged Weight | Delivered Pricing Fabric Grade 1 & C.O.M. | Delivered Pricing Fabric Grade 2 | Delivered Pricing Fabric Grade 3 | Delivered Pricing C.O.V. | Delivered Pricing Vinyl Group 2V | Delivered Pricing Pallas Fabric Group P0 | Delivered Pricing Pallas Fabric Group P1 | Delivered Pricing Pallas Fabric Group P2 | Delivered Pricing Pallas Fabric Group P3 | Delivered Pricing Pallas Fabric Group P4 | TB133 add to list price |
|--|---------------------------|----------------|--------------------------|--------------------------|--------------------------|--------------------------|--------------------------|--------------------------|-------------------------|---|----------------------------------|----------------------------------|--------------------------|----------------------------------|--|--|--|--|--|-------------------------|
| | | Basic Model | Frame Color | Seat & Back Color | Surface Finish | Edge Color | Fire Code | Upholstery Color | | | | | | | | | | | | |
| <p>Upholstered Seat - Arms</p> <ul style="list-style-type: none"> Optional in-line tables 1 seat, 0 in-line table models must connect to a corner table Corner table is ordered separately | 1 Seat, 0 In-Line Table | ST1AAU/S1/IT0 | <input type="checkbox"/> | <input type="checkbox"/> | | | <input type="checkbox"/> | <input type="checkbox"/> | 35.0# | \$ 713 | \$ 747 | \$ 761 | \$ 713 | \$ 761 | \$ 758 | \$ 803 | \$ 826 | \$ 853 | \$ 873 | \$ 84 |
| | 1 Seat, 1 In-Line Table | ST2AAU/S1/IT1 | <input type="checkbox"/> | <input type="checkbox"/> | <input type="checkbox"/> | <input type="checkbox"/> | <input type="checkbox"/> | <input type="checkbox"/> | 49.0# | 1236 | 1269 | 1281 | 1236 | 1281 | 1277 | 1323 | 1349 | 1376 | 1395 | 168 |
| | 2 Seats, 0 In-Line Table | ST2AAU/S2/IT0 | <input type="checkbox"/> | <input type="checkbox"/> | | | <input type="checkbox"/> | <input type="checkbox"/> | 60.0# | 1341 | 1405 | 1436 | 1341 | 1436 | 1429 | 1519 | 1571 | 1618 | 1658 | 251 |
| | 2 Seats, 1 In-Line Table | ST3AAU/S2/IT1 | <input type="checkbox"/> | <input type="checkbox"/> | <input type="checkbox"/> | <input type="checkbox"/> | <input type="checkbox"/> | <input type="checkbox"/> | 74.0# | 1948 | 2015 | 2058 | 1948 | 2058 | 2050 | 2143 | 2192 | 2241 | 2281 | 168 |
| | 3 Seats, 0 In-Line Table | ST3AAU/S3/IT0 | <input type="checkbox"/> | <input type="checkbox"/> | | | <input type="checkbox"/> | <input type="checkbox"/> | 85.0# | 1964 | 2066 | 2109 | 1964 | 2109 | 2100 | 2237 | 2311 | 2384 | 2445 | 251 |
| ST1U | 3 Seats, 1 In-line Table | ST4AAU/S3/IT1 | <input type="checkbox"/> | <input type="checkbox"/> | <input type="checkbox"/> | <input type="checkbox"/> | <input type="checkbox"/> | <input type="checkbox"/> | 99.0# | 2576 | 2674 | 2718 | 2576 | 2718 | 2706 | 2844 | 2917 | 2993 | 3053 | 251 |
| ST2U | 4 Seats, 0 In-line Table | ST4AAU/S4/IT0 | <input type="checkbox"/> | <input type="checkbox"/> | | | <input type="checkbox"/> | <input type="checkbox"/> | 110.0# | 2591 | 2726 | 2784 | 2591 | 2784 | 2769 | 2952 | 3051 | 3148 | 3230 | 334 |
| ST3U | 3 Seats, 2 In-Line Tables | ST5AAU/S3/IT2 | <input type="checkbox"/> | <input type="checkbox"/> | <input type="checkbox"/> | <input type="checkbox"/> | <input type="checkbox"/> | <input type="checkbox"/> | 118.0# | 3183 | 3281 | 3328 | 3183 | 3328 | 3315 | 3453 | 3527 | 3600 | 3662 | 251 |
| ST4U | 4 Seats, 1 In-line Table | ST5AAU/S4/IT1 | <input type="checkbox"/> | <input type="checkbox"/> | <input type="checkbox"/> | <input type="checkbox"/> | <input type="checkbox"/> | <input type="checkbox"/> | 129.0# | 3201 | 3335 | 3391 | 3201 | 3391 | 3375 | 3560 | 3658 | 3757 | 3839 | 334 |
| ST5U | 5 Seats, 0 In-line Table | ST5AAU/S5/IT0 | <input type="checkbox"/> | <input type="checkbox"/> | | | <input type="checkbox"/> | <input type="checkbox"/> | 140.0# | 3218 | 3386 | 3456 | 3218 | 3456 | 3439 | 3667 | 3791 | 3915 | 4013 | 417 |
| <p>Upholstered Seat and Back - No Arms</p> <ul style="list-style-type: none"> Optional in-line tables 1 seat, 0 in-line table models must connect to a corner table Corner table is ordered separately | 1 Seat, 0 In-Line Table | ST1NAUB/S1/IT0 | <input type="checkbox"/> | <input type="checkbox"/> | | | <input type="checkbox"/> | <input type="checkbox"/> | 35.0# | \$ 602 | \$ 638 | \$ 650 | \$ 602 | \$ 650 | \$ 647 | \$ 693 | \$ 716 | \$ 742 | \$ 762 | \$ 119 |
| | 1 Seat, 1 In-Line Table | ST2NAUB/S1/IT1 | <input type="checkbox"/> | <input type="checkbox"/> | <input type="checkbox"/> | <input type="checkbox"/> | <input type="checkbox"/> | <input type="checkbox"/> | 49.0# | 1127 | 1159 | 1139 | 1127 | 1139 | 1136 | 1183 | 1208 | 1254 | 1252 | 119 |
| | 2 Seats, 0 In-Line Table | ST2NAUB/S2/IT0 | <input type="checkbox"/> | <input type="checkbox"/> | | | <input type="checkbox"/> | <input type="checkbox"/> | 60.0# | 1208 | 1273 | 1304 | 1208 | 1304 | 1296 | 1386 | 1436 | 1485 | 1463 | 238 |
| | 2 Seats, 1 In-Line Table | ST3NAUB/S2/IT1 | <input type="checkbox"/> | <input type="checkbox"/> | <input type="checkbox"/> | <input type="checkbox"/> | <input type="checkbox"/> | <input type="checkbox"/> | 74.0# | 1873 | 1941 | 1969 | 1873 | 1969 | 1963 | 2055 | 2103 | 2151 | 2192 | 238 |
| | 3 Seats, 0 In-Line Table | ST3NAUB/S3/IT0 | <input type="checkbox"/> | <input type="checkbox"/> | | | <input type="checkbox"/> | <input type="checkbox"/> | 85.0# | 1809 | 1910 | 1952 | 1809 | 1952 | 1942 | 2080 | 2152 | 2227 | 2288 | 356 |
| ST1UB | 3 Seats, 1 In-Line Table | ST4NAUB/S3/IT1 | <input type="checkbox"/> | <input type="checkbox"/> | <input type="checkbox"/> | <input type="checkbox"/> | <input type="checkbox"/> | <input type="checkbox"/> | 99.0# | 2333 | 2430 | 2475 | 2333 | 2475 | 2464 | 2602 | 2674 | 2747 | 2808 | 356 |
| ST2UB | 4 Seats, 0 In-Line Table | ST4NAUB/S4/IT0 | <input type="checkbox"/> | <input type="checkbox"/> | | | <input type="checkbox"/> | <input type="checkbox"/> | 110.0# | 2412 | 2546 | 2605 | 2412 | 2605 | 2590 | 2774 | 2873 | 2969 | 3052 | 476 |
| ST3UB | 3 Seats, 2 In-Line Tables | ST5NAUB/S3/IT2 | <input type="checkbox"/> | <input type="checkbox"/> | <input type="checkbox"/> | <input type="checkbox"/> | <input type="checkbox"/> | <input type="checkbox"/> | 118.0# | 2853 | 2953 | 2998 | 2853 | 2998 | 2986 | 3123 | 3196 | 3270 | 3332 | 356 |
| ST4UB | 4 Seats, 1 In-Line Table | ST5NAUB/S4/IT1 | <input type="checkbox"/> | <input type="checkbox"/> | <input type="checkbox"/> | <input type="checkbox"/> | <input type="checkbox"/> | <input type="checkbox"/> | 129.0# | 2934 | 3067 | 3127 | 2934 | 3127 | 3111 | 3295 | 3391 | 3491 | 3573 | 476 |
| ST5UB | 5 Seats, 0 In-Line Table | ST5NAUB/S5/IT0 | <input type="checkbox"/> | <input type="checkbox"/> | | | <input type="checkbox"/> | <input type="checkbox"/> | 140.0# | 3015 | 3183 | 3257 | 3015 | 3257 | 3236 | 3464 | 3589 | 3711 | 3813 | 595 |

A **B** **C** **D** **E** **F** **G**

HOW TO ORDER

- Indicate the following information on order form:
- Quantity of each item.
 - Model number, including options. See "How To Build a Model Number".
 - Any special service required.

Note: • The indicates that a choice is required.
 • The absence of the indicates that no choice is required.
 • Alpha-numeric characters in place of indicate that no other alternatives are available.

HOW TO BUILD A MODEL NUMBER

- A** Select basic model.
- B** Select frame color. Refer to the **Product Color Options** page in this price list.
- C** Select seat/back color. Refer to the **Product Color Options** page in this price list.
- D** Select surface finish for table. Refer to the **Product Color Options** page in this price list. Surface finish offerings are based on edge style selections.
- E** Select table edge color. Refer to the **Product Color Options** page in this price list. Edge color offerings are based on edge style selections.

- F** Select fire code.
NFR - Compliance to TB 117-2013
FR - Compliance to TB 133
 See pricing column for TB133 upcharge.
- G** Select upholstery grade/color. Refer to ki.com/fabrics

UPHOLSTERY INFORMATION

C.O.M. Upholstery
 C.O.M. requirement for 10 chairs or less with upholstered seat or upholstered seat and back is 3/4 yard per chair of 54" wide nondirectional fabric. For orders of 11 or more with upholstered seat and back and for complete information on ordering C.O.M. see "Ordering C.O.M., C.O.V. and C.O.L." section.

OPTIONS

California TB133 Fire Safety Code
 The above seating products can be manufactured using the appropriate flame-retardant materials for compliance to California Technical Bulletin 133. See pricing column for upcharge. Please contact KI customer service for fabric compliance. No additional lead time.



SPECIAL SERVICES

Special Carton Marking
 With specially marked information N/C

Shipping
 Ships **knocked down, FOB Green Bay, WI 54302, freight prepaid.** Freight class 70.

Specifications and prices are subject to change without prior notice.



| MODEL | Features | MODEL NUMBER | | | | | | | Approx. Packaged Weight | Delivered Pricing Fabric Grade 1 & C.O.M. | Delivered Pricing Fabric Grade 2 | Delivered Pricing Fabric Grade 3 | Delivered Pricing C.O.V. | Delivered Pricing Vinyl Group 2V | Delivered Pricing Pallas Fabric Group P0 | Delivered Pricing Pallas Fabric Group P1 | Delivered Pricing Pallas Fabric Group P2 | Delivered Pricing Pallas Fabric Group P3 | Delivered Pricing Pallas Fabric Group P4 | TB133 add to list price |
|---|---------------------------|----------------|--------------------------|--------------------------|--------------------------|--------------------------|--------------------------|--------------------------|-------------------------|---|----------------------------------|----------------------------------|--------------------------|----------------------------------|--|--|--|--|--|-------------------------|
| | | Basic Model | Frame Color | Seat & Back Color | Surface Finish | Edge Color | Fire Code | Upholstery Color | | | | | | | | | | | | |
|  <p>Upholstered Seat and Back - End Arms Only</p> <ul style="list-style-type: none"> Optional in-line tables 1 seat, 0 in-line table models must connect to a corner table Corner table is ordered separately | 1 Seat, 0 In-Line Table | ST1EAUB/S1/IT0 | <input type="checkbox"/> | <input type="checkbox"/> | | | <input type="checkbox"/> | <input type="checkbox"/> | 35.0# | \$ 777 | \$ 810 | \$ 825 | \$ 777 | \$ 825 | \$ 821 | \$ 867 | \$ 889 | \$ 918 | \$ 935 | \$ 119 |
| | 1 Seat, 1 In-Line Table | ST2EAUB/S1/IT1 | <input type="checkbox"/> | <input type="checkbox"/> | <input type="checkbox"/> | <input type="checkbox"/> | <input type="checkbox"/> | <input type="checkbox"/> | 49.0# | 1212 | 1245 | 1260 | 1212 | 1260 | 1258 | 1304 | 1325 | 1351 | 1372 | 119 |
| | 2 Seats, 0 In-Line Table | ST2EAUB/S2/IT0 | <input type="checkbox"/> | <input type="checkbox"/> | | | <input type="checkbox"/> | <input type="checkbox"/> | 52.0# | 1380 | 1446 | 1478 | 1380 | 1478 | 1469 | 1560 | 1608 | 1658 | 1699 | 238 |
| | 2 Seats, 1 In-Line Table | ST3EAUB/S2/IT1 | <input type="checkbox"/> | <input type="checkbox"/> | <input type="checkbox"/> | <input type="checkbox"/> | <input type="checkbox"/> | <input type="checkbox"/> | 60.0# | 1903 | 1969 | 1998 | 1903 | 1998 | 1991 | 2082 | 2132 | 2180 | 2223 | 238 |
| | 3 Seats, 0 In-Line Table | ST3EAUB/S3/IT0 | <input type="checkbox"/> | <input type="checkbox"/> | | | <input type="checkbox"/> | <input type="checkbox"/> | 69.0# | 1985 | 2083 | 2127 | 1985 | 2127 | 2115 | 2252 | 2326 | 2401 | 2461 | 356 |
| ST1UB | 3 Seats, 1 In-Line Table | ST4EAUB/S3/IT1 | <input type="checkbox"/> | <input type="checkbox"/> | <input type="checkbox"/> | <input type="checkbox"/> | <input type="checkbox"/> | <input type="checkbox"/> | 75.0# | 2507 | 2606 | 2650 | 2507 | 2650 | 2639 | 2776 | 2848 | 2922 | 2986 | 356 |
| ST2UB | 4 Seats, 0 In-Line Table | ST4EAUB/S4/IT0 | <input type="checkbox"/> | <input type="checkbox"/> | | | <input type="checkbox"/> | <input type="checkbox"/> | 86.0# | 2585 | 2720 | 2780 | 2585 | 2780 | 2762 | 2947 | 3045 | 3142 | 3224 | 476 |
| ST3UB | 3 Seats, 2 In-Line Tables | ST5EAUB/S3/IT2 | <input type="checkbox"/> | <input type="checkbox"/> | <input type="checkbox"/> | <input type="checkbox"/> | <input type="checkbox"/> | <input type="checkbox"/> | 94.0# | 3026 | 3128 | 3172 | 3026 | 3172 | 3160 | 3297 | 3371 | 3445 | 3507 | 356 |
| ST4UB | 4 Seats, 1 In-Line Table | ST5EAUB/S4/IT1 | <input type="checkbox"/> | <input type="checkbox"/> | <input type="checkbox"/> | <input type="checkbox"/> | <input type="checkbox"/> | <input type="checkbox"/> | 105.0# | 3107 | 3242 | 3301 | 3107 | 3301 | 3283 | 3469 | 3566 | 3665 | 3746 | 476 |
| ST5UB | 5 Seats, 0 In-Line Table | ST5EAUB/S5/IT0 | <input type="checkbox"/> | <input type="checkbox"/> | | | <input type="checkbox"/> | <input type="checkbox"/> | 110.0# | 3189 | 3355 | 3429 | 3189 | 3429 | 3412 | 3640 | 3762 | 3885 | 3987 | 595 |
|  <p>Upholstered Seat and Back - Arms</p> <ul style="list-style-type: none"> Optional in-line tables 1 seat, 0 in-line table models must connect to a corner table Corner table is ordered separately | 1 Seat, 0 In-Line Table | ST1AAUB/S1/IT0 | <input type="checkbox"/> | <input type="checkbox"/> | | | <input type="checkbox"/> | <input type="checkbox"/> | 35.0# | \$ 777 | \$ 810 | \$ 825 | \$ 777 | \$ 825 | \$ 821 | \$ 867 | \$ 889 | \$ 918 | \$ 935 | \$ 119 |
| | 1 Seat, 1 In-Line Table | ST2AAUB/S1/IT1 | <input type="checkbox"/> | <input type="checkbox"/> | <input type="checkbox"/> | <input type="checkbox"/> | <input type="checkbox"/> | <input type="checkbox"/> | 49.0# | 1301 | 1334 | 1347 | 1301 | 1347 | 1343 | 1389 | 1413 | 1438 | 1457 | 119 |
| | 2 Seats, 0 In-Line Table | ST2AAUB/S2/IT0 | <input type="checkbox"/> | <input type="checkbox"/> | | | <input type="checkbox"/> | <input type="checkbox"/> | 60.0# | 1467 | 1534 | 1563 | 1467 | 1563 | 1555 | 1647 | 1696 | 1745 | 1787 | 238 |
| | 2 Seats, 1 In-Line Table | ST3AAUB/S2/IT1 | <input type="checkbox"/> | <input type="checkbox"/> | <input type="checkbox"/> | <input type="checkbox"/> | <input type="checkbox"/> | <input type="checkbox"/> | 74.0# | 2076 | 2143 | 2187 | 2076 | 2187 | 2180 | 2272 | 2318 | 2370 | 2408 | 238 |
| | 3 Seats, 0 In-Line Table | ST3AAUB/S3/IT0 | <input type="checkbox"/> | <input type="checkbox"/> | | | <input type="checkbox"/> | <input type="checkbox"/> | 85.0# | 2156 | 2258 | 2301 | 2156 | 2301 | 2289 | 2426 | 2500 | 2576 | 2637 | 356 |
| ST1UB | 3 Seats, 1 In-Line Table | ST4AAUB/S3/IT1 | <input type="checkbox"/> | <input type="checkbox"/> | <input type="checkbox"/> | <input type="checkbox"/> | <input type="checkbox"/> | <input type="checkbox"/> | 99.0# | 2769 | 2866 | 2911 | 2769 | 2911 | 2899 | 3037 | 3111 | 3183 | 3244 | 356 |
| ST2UB | 4 Seats, 0 In-Line Table | ST4AAUB/S4/IT0 | <input type="checkbox"/> | <input type="checkbox"/> | | | <input type="checkbox"/> | <input type="checkbox"/> | 110.0# | 2847 | 2982 | 3040 | 2847 | 3040 | 3024 | 3208 | 3305 | 3403 | 3485 | 476 |
| ST3UB | 3 Seats, 2 In-Line Tables | ST5AAUB/S3/IT2 | <input type="checkbox"/> | <input type="checkbox"/> | <input type="checkbox"/> | <input type="checkbox"/> | <input type="checkbox"/> | <input type="checkbox"/> | 118.0# | 3375 | 3476 | 3519 | 3375 | 3519 | 3510 | 3647 | 3720 | 3793 | 3852 | 356 |
| ST4UB | 4 Seats, 1 In-Line Table | ST5AAUB/S4/IT1 | <input type="checkbox"/> | <input type="checkbox"/> | <input type="checkbox"/> | <input type="checkbox"/> | <input type="checkbox"/> | <input type="checkbox"/> | 129.0# | 3455 | 3590 | 3649 | 3455 | 3649 | 3632 | 3815 | 3915 | 4012 | 4094 | 476 |
| ST5UB | 5 Seats, 0 In-Line Table | ST5AAUB/S5/IT0 | <input type="checkbox"/> | <input type="checkbox"/> | | | <input type="checkbox"/> | <input type="checkbox"/> | 140.0# | 3539 | 3706 | 3777 | 3539 | 3777 | 3758 | 3987 | 4110 | 4232 | 4333 | 595 |

A **B** **C** **D** **E** **F** **G**

HOW TO ORDER

- Indicate the following information on order form:
- Quantity of each item.
 - Model number, including options. See "How To Build a Model Number".
 - Any special service required.

Note:

- The indicates that a choice is required.
- The absence of the indicates that no choice is required.
- Alpha-numeric characters in place of indicate that no other alternatives are available.

HOW TO BUILD A MODEL NUMBER

- A** Select basic model.
- B** Select frame color. Refer to the **Product Color Options** page in this price list.
- C** Select seat/back color. Refer to the **Product Color Options** page in this price list.
- D** Select surface finish for table. Refer to the **Product Color Options** page in this price list. Surface finish offerings are based on edge style selections.
- E** Select table edge color. Refer to the **Product Color Options** page in this price list. Edge color offerings are based on edge style selections.

- F** Select fire code.
 - NFR** - Compliance to TB 117-2013
 - FR** - Compliance to TB 133
 See pricing column for TB133 upcharge.

- G** Select upholstery grade/color. Refer to ki.com/fabrics

UPHOLSTERY INFORMATION

C.O.M. Upholstery
 C.O.M. requirement for 10 chairs or less with upholstered seat or upholstered seat and back is 3/4 yard per chair of 54" wide nondirectional fabric. For orders of 11 or more with upholstered seat and back and for complete information on ordering C.O.M. see "Ordering C.O.M., C.O.V. and C.O.L." section.

OPTIONS

California TB133 Fire Safety Code
 The above seating products can be manufactured using the appropriate flame-retardant materials for compliance to California Technical Bulletin 133. See pricing column for upcharge. Please contact KI customer service for fabric compliance. No additional lead time.

SPECIAL SERVICES

Special Carton Marking
 With specially marked information N/C

Shipping
 Ships **knocked down, FOB Green Bay, WI 54302, freight prepaid.** Freight class 70.

Specifications and prices are subject to change without prior notice.



| MODEL | Features | MODEL NUMBER | | | | Approx. Packaged Weight | Delivered Pricing |
|--|------------------|--------------|---|--|--|-------------------------|-------------------|
| | | Basic Model | Frame Color | Surface Finish | Edge Color | | |
|  MSCT Corner Table • Number of tables per arrangement • Plastic laminate with vinyl bullnose edge • For mounting modular units at a 90° angle • Two required for U-shaped configuration • One required for L-shaped configuration | Connects 2 units | TCT | <input type="checkbox"/> <input type="checkbox"/> | <input type="checkbox"/> <input type="checkbox"/> <input type="checkbox"/> | <input type="checkbox"/> <input type="checkbox"/> <input type="checkbox"/> | 0.0# | \$ 704 |
| | | | | | | | |
| HRDPT Back Ganging Bar • Connects 2 units back-to-back • Powder coated to match base • Sold in pairs | | DOP.GANG | <input type="checkbox"/> <input type="checkbox"/> | | | 8.0# | \$ 235 |
| | | | | | | | |

A **B** **C** **D**

HOW TO ORDER

- Indicate the following information on order form:
- Quantity of each item.
 - Model number, including options. See "How To Build a Model Number".
 - Any special service required.

Note:

- The indicates that a choice is required.
- The absence of the indicates that no choice is required.
- Alpha-numeric characters in place of indicate that no other alternatives are available.

HOW TO BUILD A MODEL NUMBER

- A** Select basic model.
- B** Select frame color. Refer to the **Product Color Options** page in this price list.
- C** Select surface finish for table. Refer to the **Product Color Options** page in this price list.
- D** Select table edge color. Refer to the **Product Color Options** page in this price list.

UPHOLSTERY INFORMATION

C.O.M. Upholstery
 C.O.M. requirement for 10 chairs or less with upholstered seat or upholstered seat and back is 3/4 yard per chair of 54" wide nondirectional fabric. For orders of 11 or more with upholstered seat and back and for complete information on ordering C.O.M. see "Ordering C.O.M., C.O.V. and C.O.L." section.

OPTIONS

California TB133 Fire Safety Code
 The above seating products can be manufactured using the appropriate flame-retardant materials for compliance to California Technical Bulletin 133. See pricing column for upcharge. Please contact KI customer service for fabric compliance. No additional lead time.

SPECIAL SERVICES

Special Carton Marking
 With specially marked information N/C

Shipping
 Ships **knocked down, FOB Green Bay, WI 54302, freight prepaid.** Freight class 70.

Specifications and prices are subject to change without prior notice.



Task Cantilever Armchair



Armless Task Stool



ChangeUp Tablet Arm Task Chair

| Features | | | |
|--|-------------------|-------------------|-------------------|
| Comfort Tilt Mechanism option | • | | |
| Poly, upholstered seat, or upholstered seat/back | • | • | • |
| Flex back | • | • | |
| General Dimensions | | | |
| Seat width | 18" | 18" | 18" |
| Seat depth | 18" | 18" | 18" |
| Seat height (upholstered - add 1") | 17-1/4" - 22-1/4" | 22-1/4" - 32-1/2" | 17-1/4" - 22-1/4" |
| Overall Dimensions | | | |
| Width | 27-1/2" | 27-1/2" | 29-1/2" |
| Depth | 27-1/2" | 27-1/2" | 31" - 35-1/4" |
| Height | 32-3/4" - 37-3/4" | 37-3/4" - 48" | 32-3/4" - 37-3/4" |
| Arms to floor | 26" - 31" | | 27" - 33" |

Backrest

Injection-molded polypropylene with integral steel cantilever springs. The combination of the slotted polypropylene back and the spring steel provides a supportive flexing back. Springs are nominal 4.5 mm diameter chrome silicon valve spring wire.

Seat and Shroud

Injection-molded polypropylene, attached directly to the structure.

Optional Upholstered Seat

Molded urethane foam is attached to an injection-molded polypropylene seat board, then upholstered using a draw-string process. The assembled seat pad is attached to the seat by means of hidden fasteners. Note: Upholstered seat is required with translucent poly backs.

Optional Upholstered Back

A 1/2" thick urethane foam is attached to an injection-molded polypropylene back board, then upholstered using a draw-string process. The assembled back pad is attached to the back by means of fasteners, which are exposed and are color-matched to the polypropylene.

Underseat Structure

Support structure is 13-gauge steel die-formed, welded to a 1" O.D. by 14-gauge tubular steel cross member.

Frame Finishes

Baked-on electrostatically-applied 30-degree gloss epoxy powder-coat paint.

Base

Injection-molded, glass-reinforced nylon 5-blade base (black or warm grey for task chair and stool). Casters have high-impact thermoplastic double-wheels. A single control paddle under the seat operates the height-adjusting pneumatic cylinder.

Casters

Casters are double-wheel (60 mm) high-impact thermoplastic. High-impact plastic frame. Casters are monochromatic with base. Carpet or hard floor casters are offered. Hard floor casters are black only.

INFORMATION

C.O.M. Testing and Production Requirements

Not all materials are suitable for upholstering this product. A 1 yd. x 54" sample must be submitted and approved prior to acceptance of an order. If the fabric is directional in pattern or weave, the direction must be indicated on the submitted sample, and additional yardage may be requested.

Test samples must be sent to:

KI
Attn: C.O.M. Specialist
1687 Westminster Drive - Gate 3
Green Bay, WI 54302

Fabric Disclaimer

Fabric will be applied as swatched by the fabric manufacturer. Fabric that is required to be applied differently than is swatched will need a Product Modification Request written specifying the direction the fabric is to be applied.

Task chairs and task stools ship knock-down. Minimal assembly is required.

KI Color Match Program

KI offers the additional option of color matching paint, polypropylene, or wood stain through Product Modification Requests. Contact Customer Service for details.

Whatever you imagine, whatever you require, KI's Color Match program lets you pick your color!

[Color Match Process - Poly Seating Information can be found here.](#)

INFORMATION

Warranty

Refer to KI Terms & Conditions document or visit ki.com

Arms

When equipped with optional cantilever arms, the supporting structure is $\frac{7}{8}$ " O.D. by 13-gauge tubular steel, welded directly to the seat support structure, and matching the seat and back color. The armcaps are injection-molded glass filled polypropylene, matching the seat and back color (when back is Diamond translucent, armcaps are Light Tone; when back is Pewter translucent, armcaps are Flannel; when back is Bronze translucent, armcaps are Chocolate). The armcaps are attached to the steel structure by means of screws.

Task Stool

In addition to the standard-height task chair, a stool-height version is available. Task stools are equipped with a pneumatic cylinder, allowing adjustment of seat heights from 22" to 32 $\frac{1}{2}$ ". The 18" diameter, adjustable-height foot ring is made of die-cast aluminum with a chrome-plated tubular steel ring and black "spokes". Stools are only offered with black or warm grey bases. The cylinders are available in black only.

Comfort-Tilt Mechanism

Optional comfort-tilt mechanism is comprised of a die-cast aluminum main housing and a steel mounting plate, with four internal steel coil compression springs. The mechanism provides 7-degrees of rearward tilt and 4-degrees of forward tilt. The tilt resistance is not adjustable. A single lever allows for seat-height adjustment.

ChangeUp™ Tablet Arm

ChangeUp tablet support is integral to the chair frame and consists of a $\frac{7}{8}$ " diameter solid steel rod welded to the front and rear support tubes. A three-piece molded plastic armrest is included and attached to the chair frame using a #10 x 2 $\frac{1}{2}$ " Phillips pan head tapping screw.

The tablet mechanism consists a die-cast aluminum housing, upper and lower plastic bearings, and 11-gauge steel clamp and tablet board support plates. The tablet mechanism is clamped onto the chair frame over two plastic bushing halves and a $\frac{5}{16}$ " diameter by 1 $\frac{3}{4}$ " hardened steel pin with a die-cast aluminum cap secured with two $\frac{1}{4}$ -20 x $\frac{3}{4}$ " button socket head cap screws. The pin creates a solid 90° up/down pivot stop and the bushings provide a smooth, quiet operation. In the use position, the tablet mechanism rotates outward from the chair back an additional 20° and permits approximately 3 $\frac{1}{2}$ " of adjustment for ingress/egress without stowing the tablet.

The tablet worksurface is 21" wide by 13 $\frac{1}{2}$ " deep (235 square inches) is secured to the tablet board support plate with twelve #12 x $\frac{5}{8}$ " Phillips flat head tapping screws. The tablet board is made of 18 mm Baltic Birch plywood with .040" high-pressure laminate top surface and .02" thick phenolic backer surface for an overall board thickness of approximately $\frac{3}{4}$ ". Edges are lacquered with a clear finish and sealed. The factory installed tablet assembly is not field installable and may not be removed.

Compliance

Support frame, mechanism and worksurface passes KI's internal testing for 250-pound weight capacity.

Strive Task ChangeUp Tablet Armchair



SPDCUTAPRH

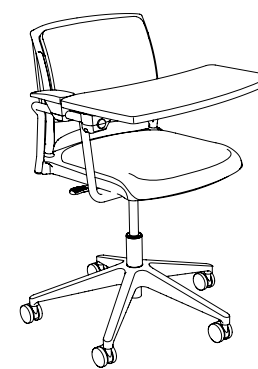

SPDCUTAUBRH

Strive Task ChangeUp Tablet Armchair

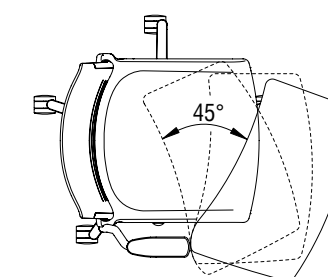
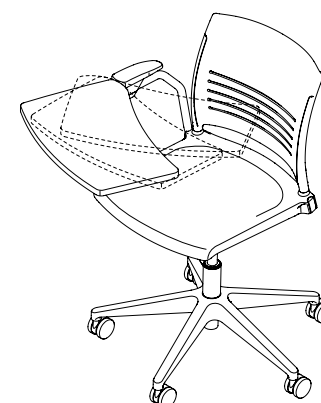
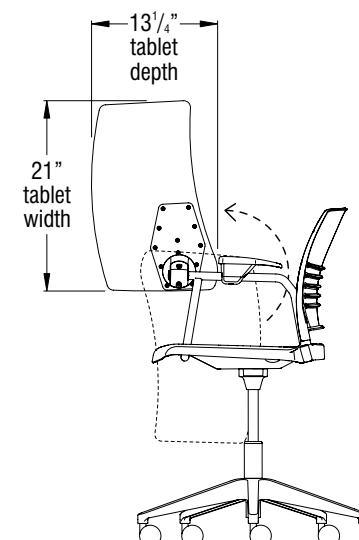
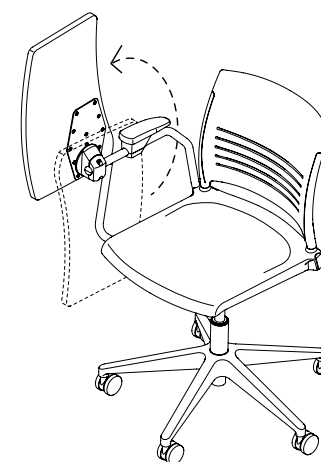
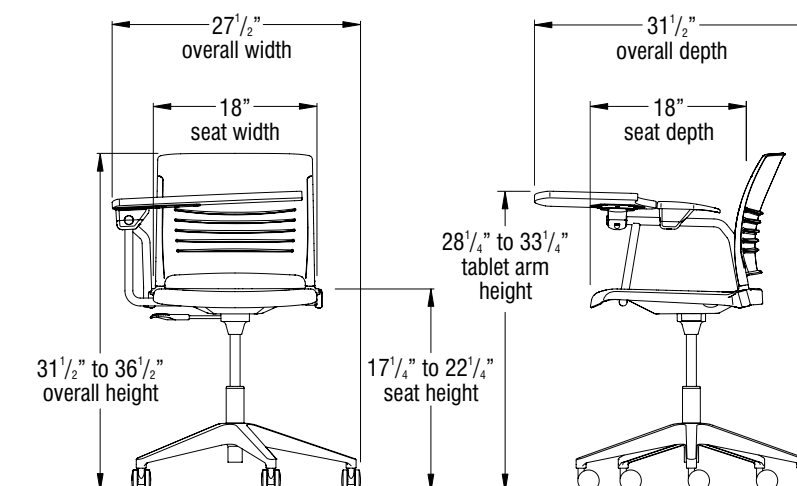



Strive Task Armless Chair

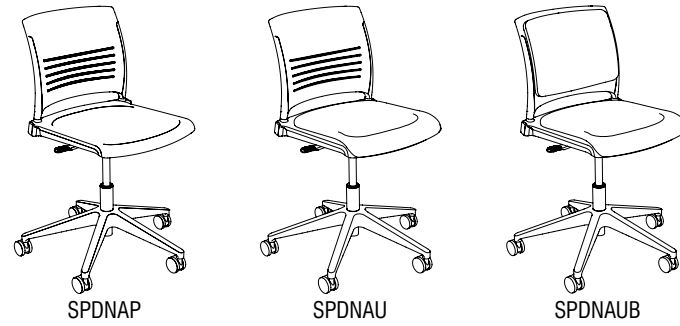

SPDNAP

SPDNAU

SPDNAUB

Strive Task Cantilever Armchair

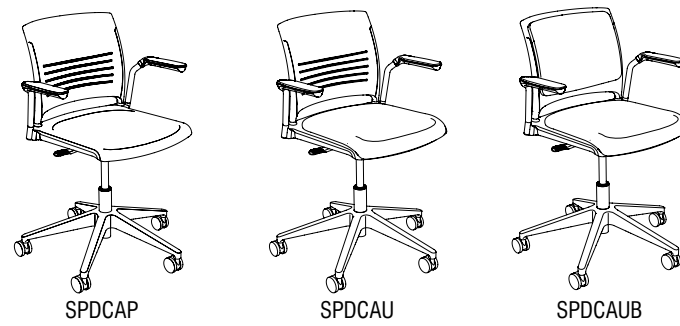

SPDCAP

SPDCAU

SPDCAUB

Strive Task Armless Chair with Comfort-Tilt Option

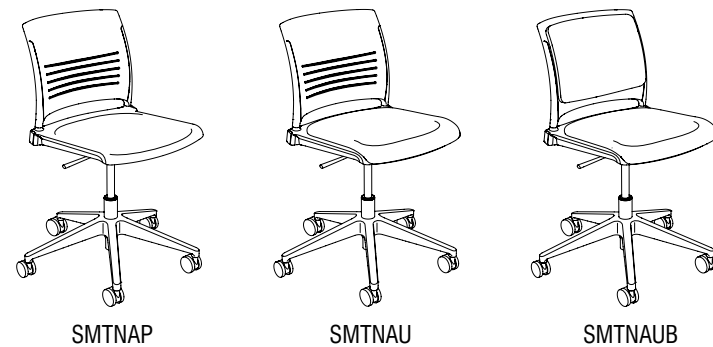

SMTNAP

SMTNAU

SMTNAUB

Strive Task Cantilever Armchair with Comfort-Tilt Option

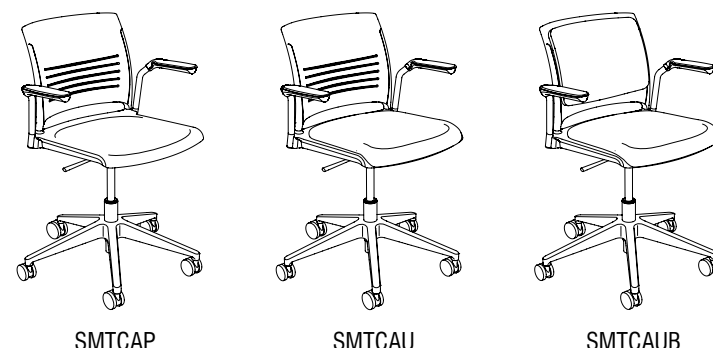

SMTCAP

SMTCAU

SMTCAUB

Strive Task Cantilever Armchair

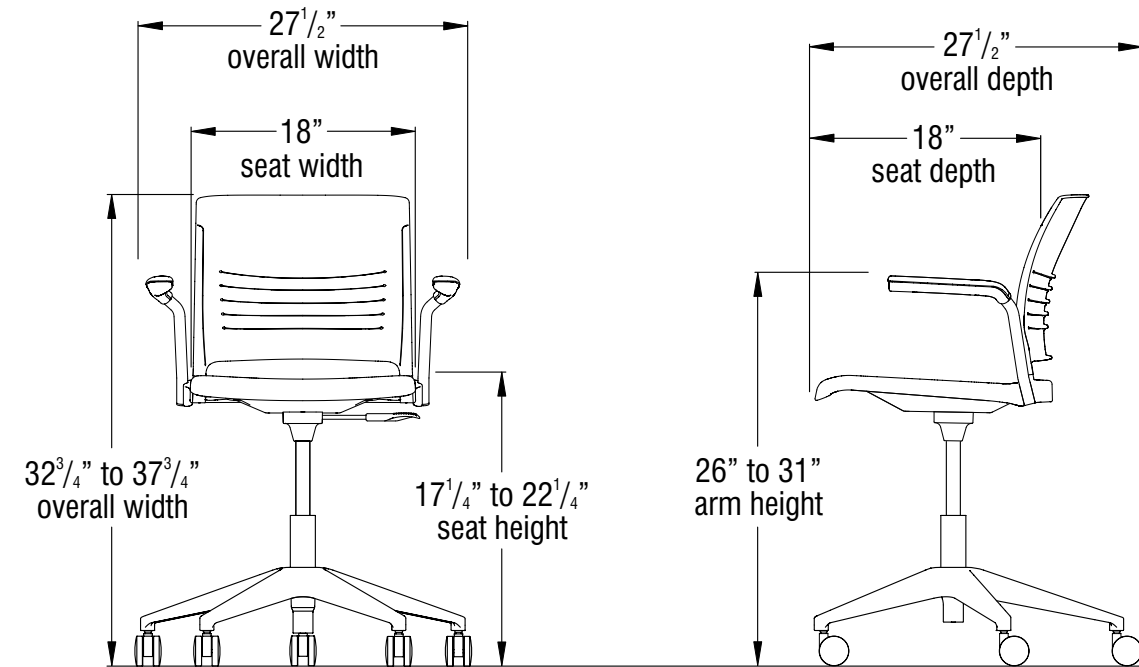

Strive Task Armless Chair with Comfort-Tilt Option

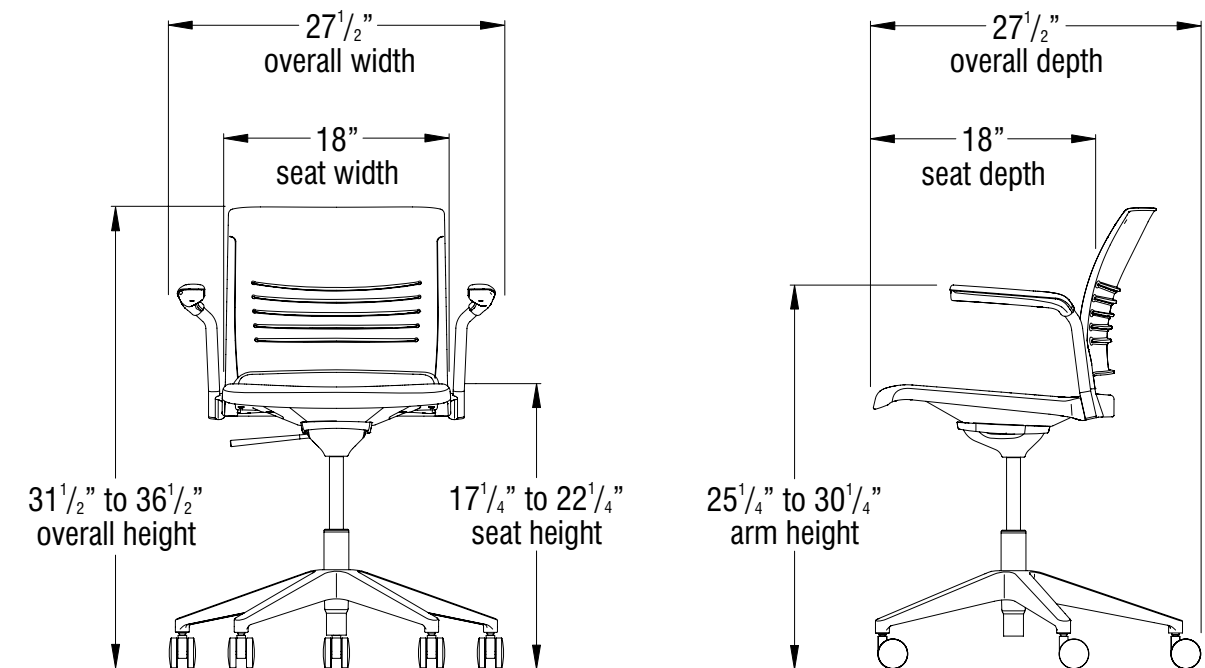



Strive Task Armless Stool

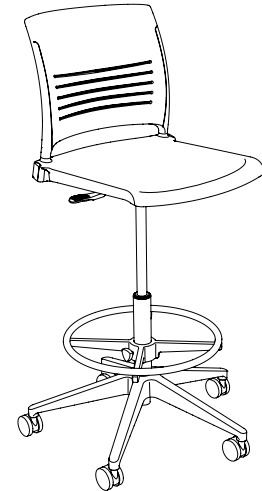

SPSNAP



SPSNAU

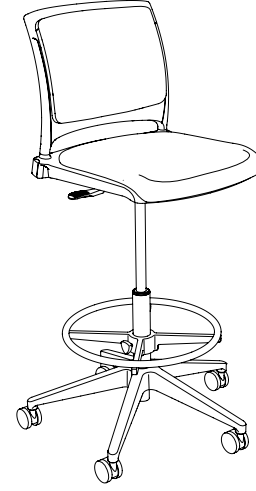

SPSNAUB

Strive Task Cantilever Arm Stool

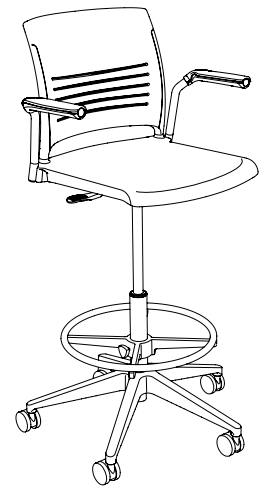

SPSCAP

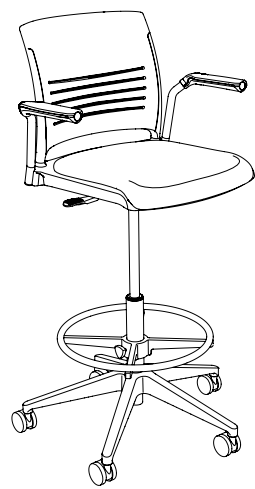

SPSCAU

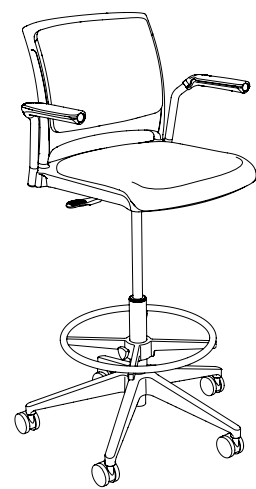

SPSCAUB

Strive Task Cantilever Arm Stool

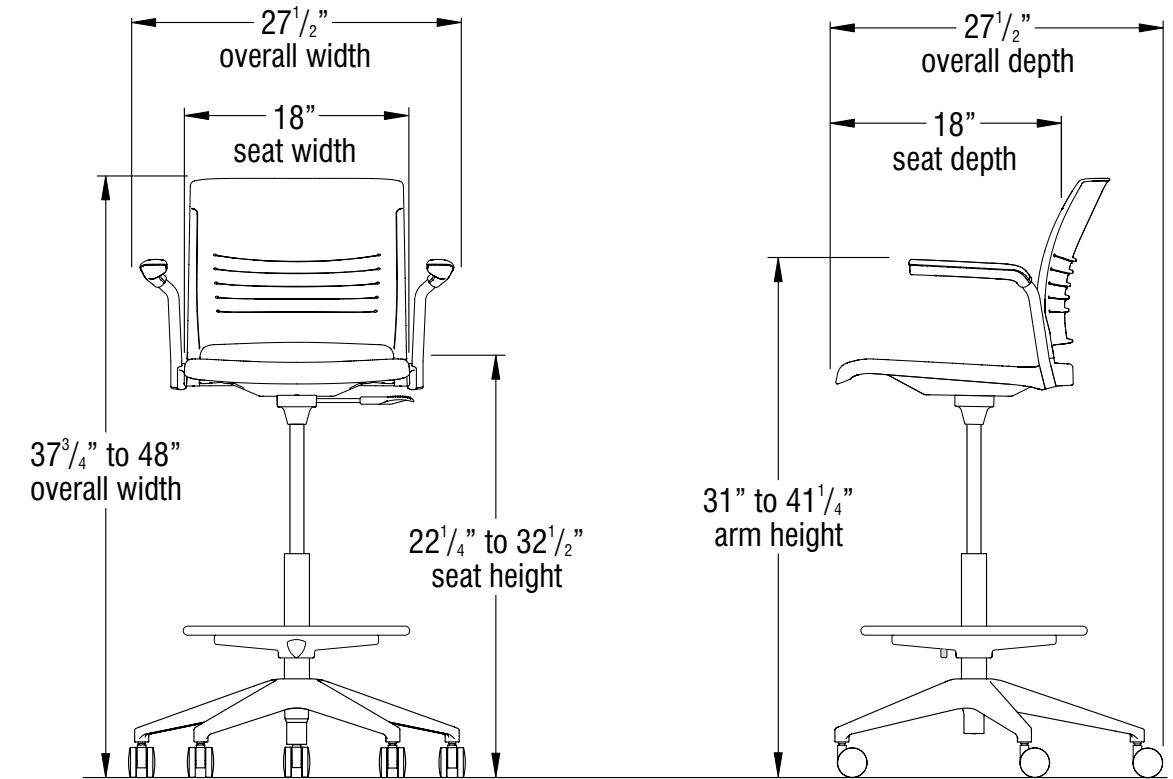

**Base/Caster Color**

| | |
|-----------|----|
| Black | BL |
| Warm Grey | WG |

Hard floor casters are black only.

Base color selection for black includes; black base, black cylinder and black carpet or hard floor casters.

Base color selection for warm grey includes; warm grey base, warm grey cylinder and warm grey carpet casters (hard floor casters not available in warm grey).

Stool cylinder is always black.

Shell Color - Polypropylene Non-Flame Retardant

| | |
|---------------------|-----|
| Black | PBL |
| Blue Grey | PGR |
| Cayenne | PCY |
| Cool Grey | PCG |
| Cottonwood | PCO |
| Diamond Translucent | PDT |
| Earthen Clay | PEY |
| Everglade Shade | PEV |
| Flannel | PFN |
| Hazy Jade | PHJ |
| Honey Bee | PHY |
| Light Tone | PLG |
| Mardi Gras | PMG |
| Misty Brown | PMY |
| Nemo | PNE |
| Nordic | PND |
| Pewter Translucent | PPT |
| Poppy Red | PPR |
| Purple Haze | PPH |
| Rubber Ducky | PRK |
| Sand | PSA |
| Sky Blue | PSK |
| Surf's Up | PSP |
| Twilight Shadow | PTI |
| Ultra Blue | PUB |
| Warm Grey | PWG |
| Zesty Lime | PZL |

Diamond Translucent and Pewter Translucent are only available on upholstered seat models.

Shell Color - Polypropylene Flame Retardant

| | |
|-------|-----|
| Black | PBL |
|-------|-----|

The above seating product can be manufactured using the appropriate flame-retardant materials for compliance to California Technical Bulletin 133.

Steel tube arm support and armcaps will match poly seat and back.

*NOTE: When FR upholstery is selected, FR poly (black only) must be selected. NFR poly is not available with FR upholstery.

Tablet Arm Color - Laminate

| | |
|--------------------|-----|
| Belair | LBO |
| Biltmore Cherry | LBT |
| Black | LBK |
| Brighton Walnut | LBW |
| Canyon Zephyr | LCA |
| Castle Oak | LCO |
| Casual Linen | LCU |
| Cherry Storm | LCX |
| Classic Linen | LCI |
| Cloud Zephyr | LCL |
| Cocobala | LCC |
| Crisp Linen | LRI |
| Desert Zephyr | LDZ |
| Dove Grey | LDG |
| Fired Steel | LIL |
| Flax Linen | LXF |
| Florence Walnut | LFC |
| Forged Steel | LOL |
| Friston Ash | LFH |
| Frosty White | LFW |
| Graphite Nebula | LGN |
| Grey | LGE |
| High Rise | LHE |
| Hollyberry | LHY |
| Irish Linen | LIH |
| Island | LID |
| Italian Silver Ash | LIT |
| Kensington Maple | LKM |
| Lapis Blue | LLB |
| Markerboard White | LMK |
| Misted Zephyr | LMR |
| Monticello Maple | LMT |
| Nickel Evolv | LNV |
| North Sea | LNA |
| Ocean | LON |
| Pearl Bisque | LPB |
| Pearl Silver | LPS |
| Pressed Linen | LPR |
| River Cherry | LRY |
| Rugged Linen | LRG |
| Satin Stainless | LSS |
| Shadow Zephyr | LSR |
| Silicon evolv | LSV |
| Sterling Ash | LAZ |
| Tailored Linen | LTL |
| Titanium evolv | LTV |
| White Nebula | LWL |
| White Sand | LWN |
| Windsor Mahogany | LWY |



Finish Cards

View color swatches for items listed within this document.

Paints**Plastics/Poly****Wood/Veneer****Laminates****Molded Edges****Edge Styles****Hard Plastics****Glass**

Certain options referenced may not be available on GSA Schedule.



| MODEL | Features | MODEL NUMBER | | | | | | Approx. Packaged Weight | Delivered Pricing Unupholstered | Delivered Pricing Fabric Grade 1 & C.O.M. | Delivered Pricing Fabric Grade 2 | Delivered Pricing Fabric Grade 3 | Delivered Pricing C.O.V. | Delivered Pricing Vinyl Group 2V | Delivered Pricing Pallas Fabric Group P0 | Delivered Pricing Pallas Fabric Group P1 | Delivered Pricing Pallas Fabric Group P2 | Delivered Pricing Pallas Fabric Group P3 | Delivered Pricing Pallas Fabric Group P4 |
|--|-----------------------|--------------|--------------------------|--------------------------|--------------------------|--------------------------|------------------|-------------------------|---------------------------------|---|----------------------------------|----------------------------------|--------------------------|----------------------------------|--|--|--|--|--|
| | | Basic Model | Base Color | Fire Code | Poly Seat/Back Color | Casters | Upholstery Color | | | | | | | | | | | | |
|  <p>Task Armless Chair • Flex back</p> | Polypropylene | SPDNAP | <input type="checkbox"/> | <input type="checkbox"/> | <input type="checkbox"/> | <input type="checkbox"/> | 32.0# | \$ 398 | | | | | | | | | | | |
| | Upholstered Seat | SPDNAU | <input type="checkbox"/> | <input type="checkbox"/> | <input type="checkbox"/> | <input type="checkbox"/> | 35.0# | N/A | 477 | 511 | 528 | 477 | 528 | 525 | 571 | 597 | 623 | 645 | |
| | Upholstered Seat/Back | SPDNAUB | <input type="checkbox"/> | <input type="checkbox"/> | <input type="checkbox"/> | <input type="checkbox"/> | 35.0# | N/A | 541 | 576 | 593 | 541 | 593 | 592 | 637 | 662 | 688 | 710 | |
|  <p>Task Cantilever Armchair • Flex back</p> | Polypropylene | SPDCAP | <input type="checkbox"/> | <input type="checkbox"/> | <input type="checkbox"/> | <input type="checkbox"/> | 35.0# | \$ 473 | | | | | | | | | | | |
| | Upholstered Seat | SPDCAU | <input type="checkbox"/> | <input type="checkbox"/> | <input type="checkbox"/> | <input type="checkbox"/> | 38.0# | N/A | 549 | 584 | 600 | 549 | 600 | 598 | 644 | 668 | 694 | 716 | |
| | Upholstered Seat/Back | SPDCAUB | <input type="checkbox"/> | <input type="checkbox"/> | <input type="checkbox"/> | <input type="checkbox"/> | 38.0# | N/A | 613 | 646 | 664 | 613 | 664 | 663 | 709 | 734 | 758 | 780 | |

A **B** **C** **D** **E** **F**

HOW TO ORDER

- Indicate the following information on order form:
- Quantity of each item.
 - Model number, including options. See "How To Build a Model Number".
 - Any special service required.

Note: • The indicates that a choice is required.
• The absence of the indicates that no choice is required.
• Alpha-numeric characters in place of indicate that no other alternatives are available.

HOW TO BUILD A MODEL NUMBER

- A** Select basic model.
- B** Select base color.
Refer to the **Product Color Options** page in this price list.
Includes base, cylinder, and carpet casters (hard floor casters are always black).
- C** Select fire code.
NFR - No Fire Retardant
FR - Compliance to TB 133
- D** Select poly seat and back color.
Refer to the **Product Color Options** page in this price list.
- E** Select caster option.
S - Hard floor casters (black only)
C - Carpet casters
- F** Select upholstery grade/color.
Refer to ki.com/fabrics

OPTIONS

California TB133 Fire Safety Code
For California Technical Bulletin 133 compliant models, add the following upcharge:

Model=Polypropylene
Added List Price=\$12

Model=Upholstered Seat
Added List Price=\$84

Model=Upholstered Seat and Back
Added List Price=\$119

UPHOLSTERY INFORMATION

C.O.M. Upholstery
C.O.M. requirement for 10 chairs or less with upholstered seat or upholstered seat and back is 3/4 yard per chair of 54" wide nondirectional fabric. For orders of 11 or more with upholstered seat and back and for complete information on ordering C.O.M. see "Ordering C.O.M., C.O.V. and C.O.L." section.

SPECIAL SERVICES



Special Carton Marking

With specially marked information N/C

Shipping
Ships **knocked down, FOB Green Bay, WI 54302, freight prepaid.** Freight class 100.

Specifications and prices are subject to change without prior notice.



| MODEL | Features | MODEL NUMBER | | | | | | Approx. Packaged Weight | Delivered Pricing Unupholstered | Delivered Pricing Fabric Grade 1 & C.O.M. | Delivered Pricing Fabric Grade 2 | Delivered Pricing Fabric Grade 3 | Delivered Pricing C.O.V. | Delivered Pricing Vinyl Group 2V | Delivered Pricing Pallas Fabric Group P0 | Delivered Pricing Pallas Fabric Group P1 | Delivered Pricing Pallas Fabric Group P2 | Delivered Pricing Pallas Fabric Group P3 | Delivered Pricing Pallas Fabric Group P4 |
|---|-----------------------|--------------|--------------------------|--------------------------|--------------------------|--------------------------|------------------|-------------------------|---------------------------------|---|----------------------------------|----------------------------------|--------------------------|----------------------------------|--|--|--|--|--|
| | | Basic Model | Base Color | Fire Code | Poly Seat/Back Color | Casters | Upholstery Color | | | | | | | | | | | | |
|  <p>Task Armless Chair, Comfort Tilt Mechanism • Flex back</p> | Polypropylene | SMTNAP | <input type="checkbox"/> | <input type="checkbox"/> | <input type="checkbox"/> | <input type="checkbox"/> | 32.0# | \$ 484 | | | | | | | | | | | |
| | Upholstered Seat | SMTNAU | <input type="checkbox"/> | <input type="checkbox"/> | <input type="checkbox"/> | <input type="checkbox"/> | 35.0# | N/A | 564 | 597 | 614 | 564 | 614 | 611 | 657 | 683 | 710 | 731 | |
| | Upholstered Seat/Back | SMTNAUB | <input type="checkbox"/> | <input type="checkbox"/> | <input type="checkbox"/> | <input type="checkbox"/> | 35.0# | N/A | 626 | 662 | 679 | 626 | 679 | 678 | 723 | 748 | 774 | 796 | |
|  <p>Task Cantilever Arm Chair, Comfort Tilt Mechanism • Flex back</p> | Polypropylene | SMTCAP | <input type="checkbox"/> | <input type="checkbox"/> | <input type="checkbox"/> | <input type="checkbox"/> | 32.0# | \$ 558 | | | | | | | | | | | |
| | Upholstered Seat | SMTCAU | <input type="checkbox"/> | <input type="checkbox"/> | <input type="checkbox"/> | <input type="checkbox"/> | 35.0# | N/A | 635 | 669 | 686 | 635 | 686 | 685 | 730 | 754 | 780 | 802 | |
| | Upholstered Seat/Back | SMTCAUB | <input type="checkbox"/> | <input type="checkbox"/> | <input type="checkbox"/> | <input type="checkbox"/> | 35.0# | N/A | 699 | 732 | 750 | 699 | 750 | 749 | 795 | 820 | 844 | 844 | |

A B C D E F

HOW TO ORDER

- Indicate the following information on order form:
- Quantity of each item.
 - Model number, including options. See "How To Build a Model Number".
 - Any special service required.

Note: • The indicates that a choice is required.
• The absence of the indicates that no choice is required.
• Alpha-numeric characters in place of indicate that no other alternatives are available.

HOW TO BUILD A MODEL NUMBER

- A** Select basic model.
- B** Select base color.
Refer to the **Product Color Options** page in this price list.
Includes base, cylinder, and carpet casters (hard floor casters are always black).
- C** Select fire code.
NFR - No Fire Retardant
FR - Compliance to TB 133
- D** Select poly seat and back color.
Refer to the **Product Color Options** page in this price list.
- E** Select caster option.
S - Hard floor casters (black only)
C - Carpet casters
- F** Select upholstery grade/color.
Refer to ki.com/fabrics

OPTIONS

California TB133 Fire Safety Code
For California Technical Bulletin 133 compliant models, add the following upcharge:

Model=Polypropylene
Added List Price=\$12

Model=Upholstered Seat
Added List Price=\$84

Model=Upholstered Seat and Back
Added List Price=\$119

UPHOLSTERY INFORMATION

C.O.M. Upholstery
C.O.M. requirement for 10 chairs or less with upholstered seat or upholstered seat and back is 3/4 yard per chair of 54" wide nondirectional fabric. For orders of 11 or more with upholstered seat and back and for complete information on ordering C.O.M. see "Ordering C.O.M., C.O.V. and C.O.L." section.

SPECIAL SERVICES

Special Carton Marking

With specially marked information N/C

Shipping
Ships **knocked down, FOB Green Bay, WI 54302, freight prepaid.** Freight class 100.

Specifications and prices are subject to change without prior notice.



| Features | MODEL NUMBER | | | | | | | Approx. Packaged Weight | Delivered Pricing Unupholstered | Delivered Pricing Fabric Grade 1 & C.O.M. | Delivered Pricing Fabric Grade 2 | Delivered Pricing Fabric Grade 3 | Delivered Pricing C.O.V. | Delivered Pricing Vinyl Group 2V | Delivered Pricing Pallas Fabric Group P0 | Delivered Pricing Pallas Fabric Group P1 | Delivered Pricing Pallas Fabric Group P2 | Delivered Pricing Pallas Fabric Group P3 |
|-----------------------------------|--------------|---|---|---|--------------------------|---|---|-------------------------|---------------------------------|---|----------------------------------|----------------------------------|--------------------------|----------------------------------|--|--|--|--|
| | Basic Model | Base Color | Fire Code | Seat & Back Color | Casters | Tablet Arm Color | Upholstery Color | | | | | | | | | | | |
| Polypropylene, Left Hand | SPDCUTAPLH | <input type="checkbox"/> <input type="checkbox"/> | <input type="checkbox"/> <input type="checkbox"/> | <input type="checkbox"/> <input type="checkbox"/> | <input type="checkbox"/> | <input type="checkbox"/> <input type="checkbox"/> | | 43.0# | \$ 833 | | | | | | | | | |
| Polypropylene, Right Hand | SPDCUTAPRH | <input type="checkbox"/> <input type="checkbox"/> | <input type="checkbox"/> <input type="checkbox"/> | <input type="checkbox"/> <input type="checkbox"/> | <input type="checkbox"/> | <input type="checkbox"/> <input type="checkbox"/> | | 43.0# | 833 | | | | | | | | | |
| Upholstered Seat, Left Hand | SPDCUTAULH | <input type="checkbox"/> <input type="checkbox"/> | <input type="checkbox"/> <input type="checkbox"/> | <input type="checkbox"/> <input type="checkbox"/> | <input type="checkbox"/> | <input type="checkbox"/> <input type="checkbox"/> | <input type="checkbox"/> <input type="checkbox"/> <input type="checkbox"/> <input type="checkbox"/> | 45.5# | N/A | 912 | 946 | 962 | 912 | 962 | 960 | 1006 | 1032 | 1058 |
| Upholstered Seat, Right Hand | SPDCUTAPRH | <input type="checkbox"/> <input type="checkbox"/> | <input type="checkbox"/> <input type="checkbox"/> | <input type="checkbox"/> <input type="checkbox"/> | <input type="checkbox"/> | <input type="checkbox"/> <input type="checkbox"/> | <input type="checkbox"/> <input type="checkbox"/> <input type="checkbox"/> <input type="checkbox"/> | 45.5# | N/A | 912 | 946 | 962 | 912 | 962 | 960 | 1006 | 1032 | 1058 |
| Upholstered Seat/Back, Left Hand | SPDCUTAULH | <input type="checkbox"/> <input type="checkbox"/> | <input type="checkbox"/> <input type="checkbox"/> | <input type="checkbox"/> <input type="checkbox"/> | <input type="checkbox"/> | <input type="checkbox"/> <input type="checkbox"/> | <input type="checkbox"/> <input type="checkbox"/> <input type="checkbox"/> <input type="checkbox"/> | 46.7# | N/A | 976 | 1010 | 1028 | 976 | 1028 | 1027 | 1071 | 1097 | 1123 |
| Upholstered Seat/Back, Right Hand | SPDCUTAUBRH | <input type="checkbox"/> <input type="checkbox"/> | <input type="checkbox"/> <input type="checkbox"/> | <input type="checkbox"/> <input type="checkbox"/> | <input type="checkbox"/> | <input type="checkbox"/> <input type="checkbox"/> | <input type="checkbox"/> <input type="checkbox"/> <input type="checkbox"/> <input type="checkbox"/> | 46.7# | N/A | 976 | 1010 | 1028 | 976 | 1028 | 1027 | 1071 | 1097 | 1123 |
| | | <input type="checkbox"/> <input type="checkbox"/> | <input type="checkbox"/> <input type="checkbox"/> | <input type="checkbox"/> <input type="checkbox"/> | <input type="checkbox"/> | <input type="checkbox"/> <input type="checkbox"/> | | | | | | | | | | | | |
| | | <input type="checkbox"/> <input type="checkbox"/> | <input type="checkbox"/> <input type="checkbox"/> | <input type="checkbox"/> <input type="checkbox"/> | <input type="checkbox"/> | <input type="checkbox"/> <input type="checkbox"/> | | | | | | | | | | | | |
| | | <input type="checkbox"/> <input type="checkbox"/> | <input type="checkbox"/> <input type="checkbox"/> | <input type="checkbox"/> <input type="checkbox"/> | <input type="checkbox"/> | <input type="checkbox"/> <input type="checkbox"/> | | | | | | | | | | | | |
| | | <input type="checkbox"/> <input type="checkbox"/> | <input type="checkbox"/> <input type="checkbox"/> | <input type="checkbox"/> <input type="checkbox"/> | <input type="checkbox"/> | <input type="checkbox"/> <input type="checkbox"/> | | | | | | | | | | | | |
| | | <input type="checkbox"/> <input type="checkbox"/> | <input type="checkbox"/> <input type="checkbox"/> | <input type="checkbox"/> <input type="checkbox"/> | <input type="checkbox"/> | <input type="checkbox"/> <input type="checkbox"/> | | | | | | | | | | | | |



SPDP
SPDU
SPDUB

Task ChangeUp Tablet Arm Chair

- Flexing Back
- Large work surface (21"W x 13.3"D)
- Work surface flips and folds
- Work surface has 20 degrees of ingress/egress movement
- Work surface rated to 250 pounds
- Chair rated to 400 pounds

A B C D E F G

HOW TO ORDER

- Indicate the following information on order form:
1. Quantity of each item.
 2. Model number, including options. See "How To Build a Model Number".
 3. Any special service required.

Note: • The indicates that a choice is required.
• The absence of the indicates that no choice is required.
• Alpha-numeric characters in place of indicate that no other alternatives are available.

HOW TO BUILD A MODEL NUMBER

- A** Select basic model.
- B** Select base color.
Refer to the **Product Color Options** page in this price list.
- C** Select fire code.
FR - Compliance to TB 133
NFR - Compliance to TB 117-2013
See Upholstery Information for TB133 upcharge.
- D** Select poly seat and back color.
Refer to the **Product Color Options** page in this price list.
- E** Select casters.
S - Hard floor casters (black only)
C - Carpet casters
- F** Select tablet arm color.
Refer to the **Product Color Options** page in this price list.
- G** Select upholstery grade/color.
Refer to ki.com/fabrics

OPTIONS

- California TB133 Fire Safety Code**
For California Technical Bulletin 133 compliant models, add the following upcharge:
- Model=Polypropylene
Added List Price=\$12
- Model=Upholstered Seat
Added List Price=\$84
- Model=Upholstered Seat and Back
Added List Price=\$119



UPHOLSTERY INFORMATION

C.O.M. Upholstery
C.O.M. requirement for 10 chairs or less with upholstered seat or upholstered seat and back is 3/4 yard per chair of 54" wide nondirectional fabric. For orders of 11 or more with upholstered seat and back and for complete information on ordering C.O.M. see "Ordering C.O.M., C.O.V. and C.O.L." section.

SPECIAL SERVICES

- Special Carton Marking**
With specially marked information N/C
- Shipping**
Ships **knocked down, FOB Green Bay, WI 54302, freight prepaid.** Freight class 100.
- Specifications and prices are subject to change without prior notice.



| MODEL | Features | MODEL NUMBER | | | | | | Approx. Packaged Weight | Delivered Pricing Unupholstered | Delivered Pricing Fabric Grade 1 & C.O.M. | Delivered Pricing Fabric Grade 2 | Delivered Pricing Fabric Grade 3 | Delivered Pricing C.O.V. | Delivered Pricing Vinyl Group 2V | Delivered Pricing Pallas Fabric Group P0 | Delivered Pricing Pallas Fabric Group P1 | Delivered Pricing Pallas Fabric Group P2 | Delivered Pricing Pallas Fabric Group P3 | Delivered Pricing Pallas Fabric Group P4 |
|--|-----------------------|--------------|--------------------------|--------------------------|--------------------------|--------------------------|------------------|-------------------------|---------------------------------|---|----------------------------------|----------------------------------|--------------------------|----------------------------------|--|--|--|--|--|
| | | Basic Model | Base Color | Fire Code | Poly Seat/Back Color | Casters | Upholstery Color | | | | | | | | | | | | |
|  Task Armless Stool • Flex back | Polypropylene | SPSNAP | <input type="checkbox"/> | <input type="checkbox"/> | <input type="checkbox"/> | <input type="checkbox"/> | 37.0# | \$ 511 | | | | | | | | | | | |
| | Upholstered Seat | SPSNAU | <input type="checkbox"/> | <input type="checkbox"/> | <input type="checkbox"/> | <input type="checkbox"/> | 39.0# | N/A | 591 | 623 | 641 | 591 | 641 | 638 | 683 | 711 | 736 | 754 | |
| | Upholstered Seat/Back | SPSNAUB | <input type="checkbox"/> | <input type="checkbox"/> | <input type="checkbox"/> | <input type="checkbox"/> | 39.0# | N/A | 653 | 688 | 705 | 653 | 705 | 703 | 748 | 775 | 801 | 820 | |
|  Task Cantilever Arm Stool • Flex back | Polypropylene | SPSCAP | <input type="checkbox"/> | <input type="checkbox"/> | <input type="checkbox"/> | <input type="checkbox"/> | 39.0# | \$ 584 | | | | | | | | | | | |
| | Upholstered Seat | SPSCAU | <input type="checkbox"/> | <input type="checkbox"/> | <input type="checkbox"/> | <input type="checkbox"/> | 41.0# | N/A | 662 | 694 | 712 | 662 | 712 | 709 | 753 | 780 | 807 | 828 | |
| | Upholstered Seat/Back | SPSCAUB | <input type="checkbox"/> | <input type="checkbox"/> | <input type="checkbox"/> | <input type="checkbox"/> | 41.0# | N/A | 725 | 758 | 776 | 725 | 776 | 773 | 818 | 845 | 870 | 891 | |
| | | | A | B | C | D | E | F | | | | | | | | | | | |

SPSP
SPSU
SPSUB

SPSP
SPSU
SPSUB

HOW TO ORDER

- Indicate the following information on order form:
- Quantity of each item.
 - Model number, including options. See "How To Build a Model Number".
 - Any special service required.

Note: • The indicates that a choice is required.
 • The absence of the indicates that no choice is required.
 • Alpha-numeric characters in place of indicate that no other alternatives are available.

HOW TO BUILD A MODEL NUMBER

- A** Select basic model.
- B** Select frame color.
Refer to the **Product Color Options** page in this price list.
Includes base, cylinder, and carpet casters (hard floor casters are always black).
- C** Select fire code.

| | |
|------------|-----------------------------|
| NFR | - Compliance to TB 117-2013 |
| FR | - Compliance to TB 133 |
- D** Select poly seat and back color.
Refer to the **Product Color Options** page in this price list.
- E** Select caster option.

| | |
|----------|-----------------------------------|
| S | - Hard floor casters (black only) |
| C | - Carpet casters |
- F** Select upholstery grade/color.
Refer to ki.com/fabrics

OPTIONS

- California TB133 Fire Safety Code**
For California Technical Bulletin 133 compliant models, add the following upcharge:
- Model=Polypropylene
Added List Price=\$12
 - Model=Upholstered Seat
Added List Price=\$84
 - Model=Upholstered Seat and Back
Added List Price=\$119

UPHOLSTERY INFORMATION

C.O.M. Upholstery
C.O.M. requirement for 10 chairs or less with upholstered seat or upholstered seat and back is 3/4 yard per chair of 54" wide nondirectional fabric. For orders of 11 or more with upholstered seat and back and for complete information on ordering C.O.M. see "Ordering C.O.M., C.O.V. and C.O.L." section.

SPECIAL SERVICES

Special Carton Marking
With specially marked information N/C

Shipping
Ships **knocked down, FOB Green Bay, WI 54302, freight prepaid.** Freight class 100.

Specifications and prices are subject to change without prior notice.

1330 Bellevue Street
P.O. Box 8100
Green Bay, WI 54308-8100
800.424.2432
ki.com

KI and Furnishing Knowledge are registered
trademarks of Krueger International, Inc.

© 2020 Krueger International, Inc.
All Rights Reserved.
Code KI-PLW-000425/KI/PDF



Furnishing Knowledge®