

National Interstate Insurance Company Headquarters, Richfield, OH / Photo: © Studio 66 LLC

Non-parallel, diverging beams and baffles create organic textures in an unlimited variety of configurations for the interior.

FEATURES AND BENEFITS

- Use twist clips to create motion
- Multitude of profile dimensions up to 12' long
- Three perforation patterns for elevated acoustics
- Standard heavy-duty 15/16" T-grid suspension
- Waste reduction with factory fabricated dimensional material
- Downweight: reduce dead load with lightweight aluminum
- Compatible with industry standard lighting, HVAC, speaker, fire safety, and security services

ATTRIBUTES



FIRE RATING:
CLASS A
PER ASTM E84
AND CAN/ULC-S102



SEISMIC RATING:
ZONES A, B, C, D, E, F



**CUSTOMIZATION
AVAILABLE**

LEED® v4

RECYCLED CONTENT

up to 85%

- ✓ MR: Building Product Disclosure
- ✓ EQ: Low-Emitting Materials
- ✓ EQ: Indoor Air Quality Assessment
- ✓ EQ: Acoustic Performance

LEED® is a registered trademark of the U.S. Green Building Council.

CERTIFICATIONS



**GREENGUARD:
GOLD CERTIFIED**



EPD AVAILABLE

COLORS AND FINISHES

A wide choice of colors and finishes as well as custom color matching are available upon request. See website for the most up to date information and to order samples. Colors are for illustration purposes only.

STANDARD PAINT COLORS



CUSTOM COLORS



WHITE FINISH OPTIONS

Powder-coat paint finish for Arctic White #1015P (Gloss 10-20); Crystalline White #1050P (Gloss 45-55); Supernova White #1085P (Gloss 80-90). Aviation White #1011P: Powder-coat paint finish offering - LRV 90 - 9% gloss finish.

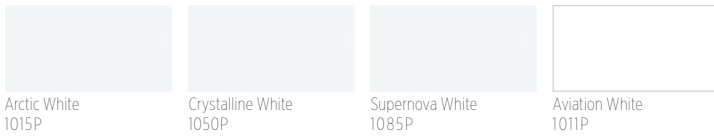

BLACK FINISH OPTIONS

Powder-coat paint finish for Starless Black #5000P (Matte); Raven Black #5030P (Gloss 25-35); Sable Black #5060P (Gloss 65-75); Wet Glass Black #5095P (Gloss 90-95)



DECORATED (POWDER-COAT) WOOD-LOOK OPTIONS

Powder-coat paint finish (interior and exterior). Formaldehyde-free, Class A composite panel. This finish is recommended for exterior conditions.

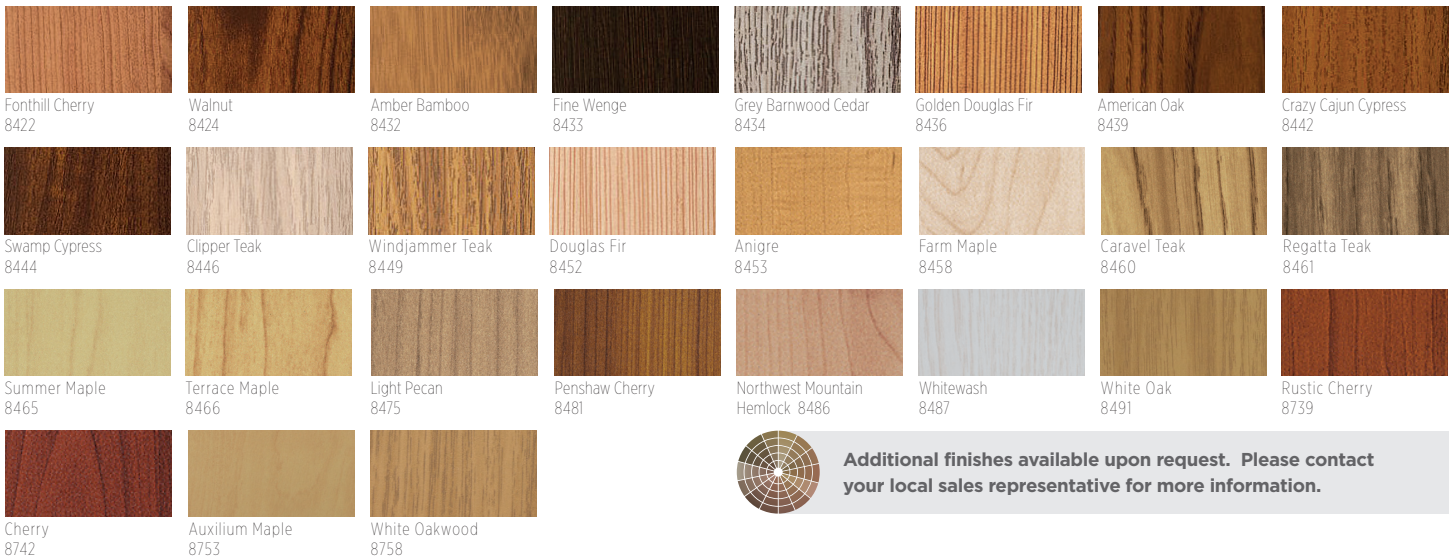

LAMINATED (FILM) WOOD FINISHES

Film (on interior, non-perforated panels only). Formaldehyde-free, Class A composite panel. Minimums apply.

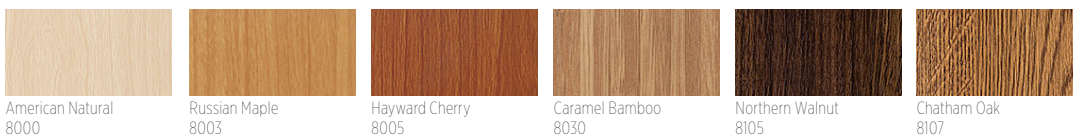

PERFORATION PATTERNS

Standard patterns shown. Perforations not available on laminated (film). Scale shown: 1:1, unless otherwise noted.

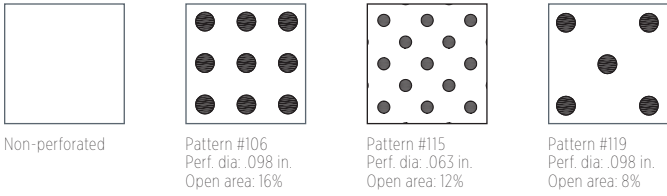

INSTALLATION EXAMPLES

Typical Isometrics

Pattern shown for illustrative purposes only. Pattern must be specified. See website for additional sizes.

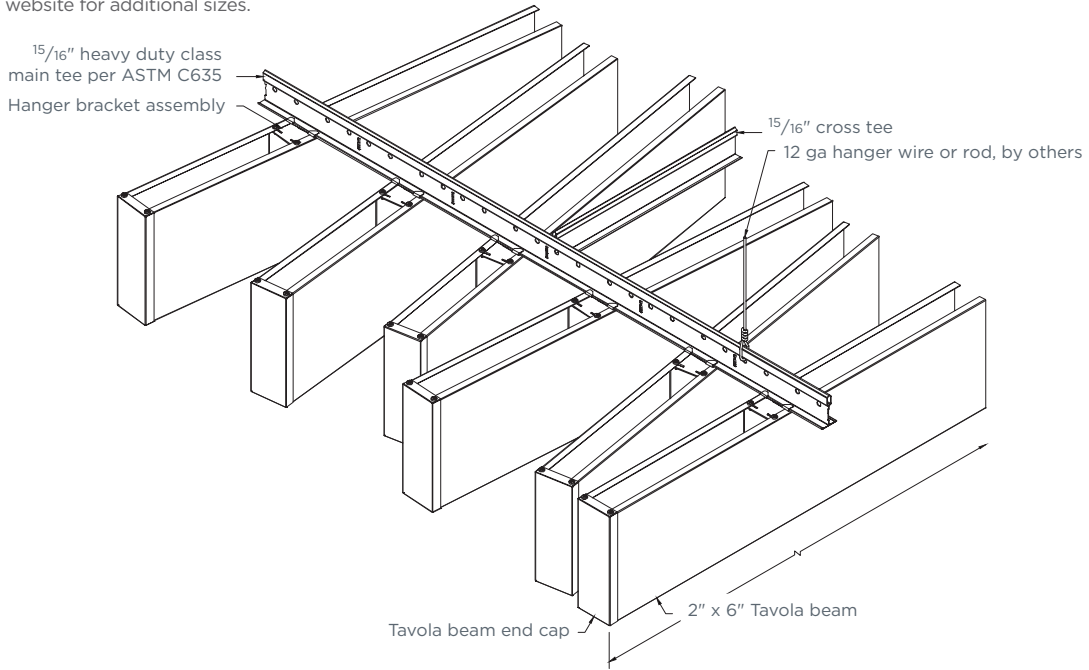

CONFIGURATIONS

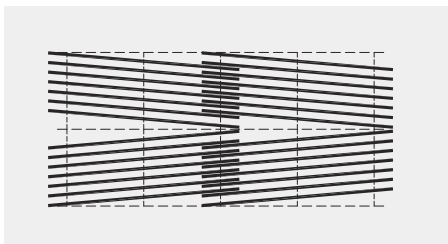

V-Pattern

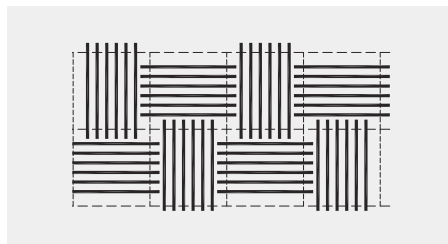

Pinwheel

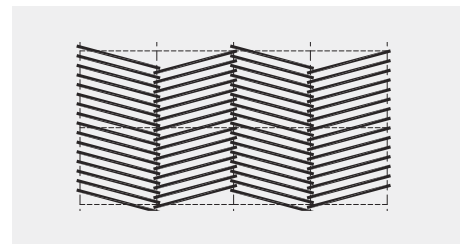

Chevron

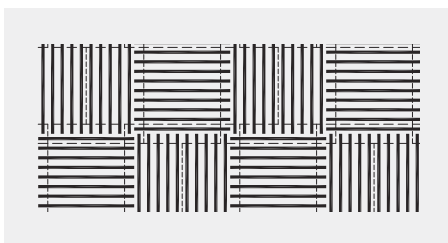

Basket Weave

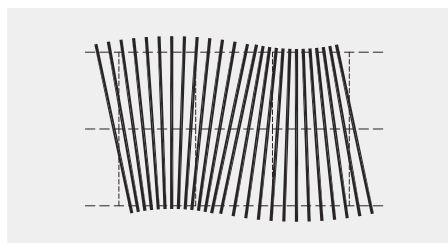

Fan

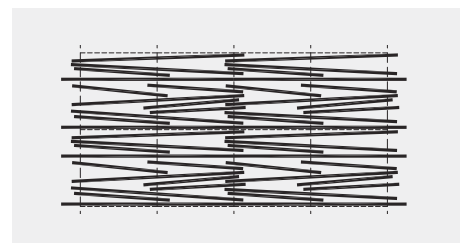

Random Alpha

 Additional options available for design flexibility, contact your local sales representative to get started.



Corporate Learning & Development Center, Fort Mill, SC / Photo: © Studio 66 LLC

PHYSICAL DATA

MATERIAL

Aluminum

WEIGHT

Varies 0.5 – 4.0 lbs./sq.ft.

FIRE RATING

Class A Fire Rated per ASTM E84

– Painted or anodized metal: Flame spread: ≤ 25, Smoke ≤ 50

– Film on metal: Flame spread: ≤ 25, Smoke ≤ 50

(for interior applications)

Class A Fire Rated per CAN/ULC-S102

– Painted or anodized metal: Flame spread: ≤ 25, Smoke ≤ 50

SEISMIC RATING

Zones A,B,C,D,E,F

WIND LOAD

N/A

RECYCLED CONTENT

Up to 85%

LIGHT REFLECTANCE (LR) COEFFICIENT

PER ASTM E1264 & ASTM E1477

– Varies with finish

– Cotton White: LR = 0.81

WARRANTY

1-year Limited Warranty.

Full warranty information can be found

at certainteed.com/warranty

ACOUSTICAL PERFORMANCE

Sound absorption can be achieved by the addition of backing ceiling panels with acoustical fabric or pad.

ACOUSTICAL BAFFLE TEST RESULTS: 2" x 6" Perforated Baffle Beam – Spacing 6" o.c. 2" x 12" Perforated Baffle Beam – Spacing 12" o.c.
2" x 8" Perforated Baffle Beam – Spacing 8" o.c. 2" x 15" Perforated Baffle Beam – Spacing 15" o.c.
2" x 10" Perforated Baffle Beam – Spacing 10" o.c.

PERFORATION PATTERN	ACOUSTICAL INFILL	2" x 6"		2" x 8"		2" x 10"		2" x 12"		2" x 15"	
		APPARENT		APPARENT		APPARENT		APPARENT		APPARENT	
		NRC	SAA	NRC	SAA	NRC	SAA	NRC	SAA	NRC	SAA
106	Non-Woven plus 1.5", 1.5 pcf fiberglass	1.00	1.00	*	*	*	*	*	*	*	*
106	Non-Woven plus 1.5", 1.5 pcf black poly encapsulated fiberglass	1.00	0.95	*	*	*	*	*	*	*	*
106	Non-Woven plus 1.5", 3.0 pcf black poly encapsulated fiberglass	1.00	0.96	*	*	*	*	*	*	*	*
106	Non-Woven	0.60	0.59	*	*	*	*	*	*	*	*
115	Non-Woven plus 1.5", 1.5 pcf black poly encapsulated fiberglass	1.10	1.09	1.10	1.11	1.15	1.16	1.15	1.16	1.20	1.21
115	1.5", 1.5 pcf black poly encapsulated fiberglass	1.05	1.05	1.05	1.04	1.10	1.11	1.10	1.09	1.15	1.16
115	Non-Woven plus 1.5", 3.0 pcf black poly encapsulated fiberglass	1.00	1.00	*	*	*	*	*	*	*	*
115	Non-Woven	0.70	0.69	0.60	0.61	0.75	0.73	0.75	0.74	0.75	0.75
119	Non-Woven plus 1.5", 1.5 pcf black poly encapsulated fiberglass	1.00	0.98	1.05	1.07	1.15	1.12	1.10	1.10	1.15	1.15
119	1.5", 1.5 pcf black poly encapsulated fiberglass	1.00	0.94	1.05	1.03	1.10	1.08	1.05	1.04	1.10	1.11
119	Non-Woven plus 1.5", 3.0 pcf black poly encapsulated fiberglass	0.90	0.94	*	*	*	*	*	*	*	*
119	Non-Woven	0.60	0.58	0.60	0.60	0.75	0.73	0.75	0.76	0.75	0.73

Tests conducted in accordance with ASTM C423 and E795, with mounting type "J". Test reports available upon request.

* Not tested

Appendix D to ASTM C423 Sound Absorption Test

Non-standard calculation of equivalent NRC Rating and Absorption Coefficients from spaced absorbers

At this time, ASTM C423 does not provide a standard method for determining absorption coefficients of spaced object absorbers. Tests of a set of sound absorbing objects spaced apart from each other will yield higher absorption rates than a specimen joined together as a single patch (A-Mount or E-Mount). For this reason it is unfair to provide NRC or absorption coefficient ratings for specimens that consist of a spaced set of absorbers. Despite this, the architectural industry has expressed great demand for a simple "single number" rating for these treatments. Likewise, acoustical consultants desire equivalent absorption coefficient data for use in acoustical modeling software. The following is an attempt to appease these demands until ASTM develops a standard method for calculation. Several alternate non-standard calculation methods are provided. Riverbank Acoustical Laboratories prefers method 1. Rating titles for these methods are prepended with the word "Apparent". These rating names and their associated acronyms are provided by RAL and shall not be misconstrued as originating from any current standard.



CertainTeed ARCHITECTURAL

METAL • WOOD • FELT • FIBERGLASS & MINERAL FIBER • GYPSUM • SUSPENSION & INTEGRATED SYSTEMS
20 Moores Road, Malvern, PA 19355 800-366-4327 certainteed.com/architectural

